

VERMILION

**Oil & Gas
Australia Pty. Ltd.**



VERMILION OIL & GAS AUSTRALIA

WANDOO FACILITY ENVIRONMENT PLAN

WPA-7000-YH-0007

Revision 16

Revision	Date	Originator	Checker	Checker	Approver
16	21 April 2021	Environmental Advisor	HSE Manager	Engineering Manager	Managing Director

Revision history

Revision	Date	Description	Originator	Checker	Approver
6	07.10.2013	Issued for NOPSEMA Acceptance	WP Environment	HSES Advisor	Managing Director
7	28.03.2014	Reissued for NOPSEMA Acceptance	WP Environment	HSES Advisor	Managing Director
8	29.08.2014	Reissued for NOPSEMA Acceptance	WP Environment	HSES Advisor	Ops Manager
9	05.10.2016	Issued for NOPSEMA Acceptance	Environmental Advisor	HSE Manager	Ops Manager
10	06.02.2017	Reissued for NOPSEMA Acceptance including proposed upgrade to PWTS	Environmental Advisor	HSE Manager	Ops Manager
11	18.04.2017	Reissued for NOPSEMA Acceptance	Environmental Advisor	HSE Manager	Ops Manager
12	21.07.2017	Reissued for NOPSEMA Acceptance (including RFI NOPSEMA comments)	Environmental Advisor	HSE Manager	Ops Manager
13	08.09.2020	Revised for resubmission to NOPSEMA under sub regulations 17 and 19	Environmental Advisor	HSE Manager Eng Manager	Managing Director
14	03.12.2020	Resubmission to NOPSEMA	Environmental Advisor	HSE Manager Eng Manager	Managing Director
15	17.02.2021	Resubmission to NOPSEMA	Environmental Advisor	HSE Manager Eng Manager	Managing Director
16	21.04.2021	Resubmission to NOPSEMA	Environmental Advisor	HSE Manager Eng Manager	Managing Director

Distribution list

Copy no.	Position	Hard Copy	Electronic Copy
1	Master copy – VOGA Document Control		X
2	VOGA Managing Director		X
3	VOGA Engineering Manager		X
4	Wandoo Field Superintendent	X	X
5	VOGA HSE Manager		X
6	VOGA Well Construction Manager		X
8	Wandoo Environmental Advisor		X
9	Wandoo Control Room	X	X
10	VOGA HSE MS Library HSE MS Element		X
11	Manager Assessment and Compliance NOPSEMA – Perth		X

Table of contents

Revision history 2

Distribution list 3

Table of contents 5

Abbreviations and definitions..... 15

1. Introduction..... 21

1.1 Background..... 21

1.2 Environment Plan Summary 21

1.3 The Proponent..... 22

1.4 Scope and purpose of the Environment Plan 22

1.4.1 Scope and Purpose 22

1.4.2 This revision 23

1.5 Corporate environmental performance philosophy 24

1.6 Applicable legislation and codes 24

1.6.1 Overview 24

1.6.2 Western Australian legislation..... 24

1.6.3 Codes of Practice 25

2. Description of activity 32

2.1 Overview..... 32

2.2 Location 34

2.3 Reservoir characteristics 34

2.4 Field infrastructure 36

2.4.1 WNA platform..... 36

2.4.2 WNB platform..... 37

2.4.3 Unutilised Assets..... 44

2.5 Hydrocarbon production 47

2.5.1 Reservoir fluids 47

2.5.2 Facility production rates 48

2.5.3 Wandoo well types 49

2.5.4 Flow lines and riser systems (platform and subsea)..... 49



2.5.5	Wells and subsurface systems (wellheads and xmas trees)	52
2.5.6	WNA process description.....	54
2.5.7	WNB process description.....	56
2.5.8	Flaring, blowdown and process venting	66
2.5.9	Process control features	67
2.5.10	Safety control systems for use during emergencies	68
2.5.11	Export of hydrocarbons	73
2.6	Support activities for operations	75
2.6.1	Crane operations	75
2.6.2	Marine vessel operations.....	75
2.6.3	Helicopter operations	76
2.6.4	Diesel bunkering	76
2.6.5	Waste management	77
2.6.6	Chemical Management.....	77
2.6.7	Power generation and compression	77
2.6.8	Laboratory.....	78
2.6.9	Potable water production.....	79
2.6.10	HVAC and refrigeration systems	79
2.7	Maintenance, inspection and project activities (on Facility).....	80
2.7.1	Rigless well intervention works	80
2.7.2	Purging of gas from vessels and tanks	81
2.7.3	Pigging with biocide	81
2.7.4	Welding and cutting.....	82
2.7.5	Chemical cleaning	82
2.7.6	Deck cleaning	82
2.7.7	Topside maintenance.....	83
2.7.8	Fire protection systems and testing	83
2.8	Maintenance, inspection and project activities (sea level and subsurface).....	84
2.8.1	Metrology	84
2.8.2	Side-scan sonar surveys	85
2.8.3	Sub-bottom profiling surveys (seismic reflection)	85
2.8.4	Metocean monitoring.....	86
2.8.5	Diving and ROV	86
2.8.6	Cleaning and marine growth removal	87
2.8.7	Subsea welding and cutting	87
2.8.8	Flowline stabilisation and support.....	88
2.8.9	Scour protection	88
2.8.10	Subsea inspection and repair.....	88
2.8.11	Cathodic protection	89
2.8.12	Flushing and leak testing	89
2.8.13	Anchoring/mooring.....	90



2.8.14	Spill response activities.....	90
2.9	Decommissioning and unutilised assets.....	91
2.9.1	Assets.....	91
2.9.2	Unutilised assets.....	92
2.9.3	Decommissioning.....	92
2.9.4	Equipment list.....	92
3.	Description of project context.....	95
3.1	Potential Environmental Hazards.....	95
3.2	Oil spill impact assessment methodology.....	100
3.2.1	Loss of Well Control.....	100
3.2.2	CGS Spill.....	100
3.2.3	Assessment of spill trajectory.....	101
3.2.4	Diesel spill.....	102
3.3	Produced Water Discharge Impact Assessment Methodology.....	102
3.3.1	Overview.....	102
3.3.2	Modelling Methodology.....	103
3.3.3	Impact Assessment Criteria.....	105
3.4	Project Areas.....	108
3.5	Environmental Performance Outcomes.....	111
4.	Description of the environment.....	113
4.1	Overview.....	113
4.2	Environment that May Be Affected.....	113
4.3	Regional Context.....	116
4.3.1	North-West Marine Region.....	117
4.3.2	South-West Marine Region.....	118
4.3.3	Outside of Australia’s Exclusive Economic Zone.....	118
4.3.4	Central Western Province.....	119
4.3.5	Central Western Shelf Province.....	119
4.3.6	Central Western Shelf Transition.....	120
4.3.7	Central Western Transition.....	120
4.3.8	Christmas Island Province.....	121
4.3.9	Cocos (Keeling) Islands Province.....	121
4.3.10	Northwest Province.....	121
4.3.11	Northwest Shelf Province.....	122
4.3.12	Northwest Shelf Transition.....	122
4.3.13	Northwest Transition.....	123



4.3.14	Southwest Shelf Transition	123
4.3.15	Southwest Transition	123
4.3.16	Timor Province.....	124
4.4	Detailed Receptor Descriptions.....	124
4.4.1	Physical environment	124
4.4.2	Key marine habitats	126
4.4.3	Key coastal communities	130
4.4.4	Key marine fauna	134
4.5	Social and economic environment	175
4.5.1	Fisheries and aquaculture.....	175
4.5.2	Commercial shipping	183
4.5.3	Defence.....	184
4.5.4	Other users	184
4.6	Values and sensitivities.....	185
4.6.1	World Heritage Areas	185
4.6.2	National Heritage Properties	187
4.6.3	Commonwealth Heritage Places.....	188
4.6.4	Underwater Cultural Heritage	191
4.6.5	Commonwealth Protected Areas.....	192
4.6.6	State Marine Protected Areas	209
4.6.7	Wetlands of international importance (Ramsar wetlands)	212
4.6.8	Key ecological features	220
4.6.9	Threatened Ecological Communities	231
5.	Risk assessment methodology.....	234
5.1	Overview.....	234
5.2	Framework.....	235
5.3	Impact assessment	236
5.4	Catastrophic Environmental Events and Critical Controls.....	237
5.4.1	Identifying Catastrophic Environmental Events.....	237
5.4.2	Identifying Critical Controls	237
5.5	Determination of Likelihood.....	237
5.6	VOGA risk ranking.....	238
5.7	Demonstrating ALARP of impact and risk.....	241
5.7.1	Ongoing operations demonstration of ALARP	241
5.7.2	Concept evaluation ALARP demonstration.....	242
5.8	Evaluating acceptability.....	244



5.9	Performance outcomes, standards and measurement criteria	246
5.10	Hazard report template.....	247
6.	Hazard assessment.....	249
6.1	Overview.....	249
6.2	Liquid hydrocarbon release from wells	253
6.2.1	Hazard report.....	253
6.2.2	Description of hazard.....	261
6.2.3	Impact assessment	263
6.2.4	Catastrophic Environmental Event identification	272
6.2.5	Critical Controls identification	272
6.2.6	Mitigation measures	272
6.2.7	Risk Ranking	279
6.2.8	ALARP demonstration.....	279
6.2.9	Acceptability demonstration	317
6.3	Liquid hydrocarbon release from export equipment, submarine hose, floating hose or export flow lines	318
6.3.1	Hazard report.....	318
6.3.2	Description of hazard.....	323
6.3.3	Impact assessment	325
6.3.4	Catastrophic Environmental Event identification	336
6.3.5	Critical Controls identification	336
6.3.6	Oil spill response strategies (mitigation)	337
6.3.7	Risk ranking.....	340
6.3.8	ALARP demonstration.....	341
6.3.9	Acceptability demonstration	344
6.4	Crude oil spill from CGS.....	345
6.4.1	Hazard report.....	345
6.4.2	Description of hazard.....	348
6.4.3	Impact assessment	348
6.4.4	Catastrophic Environmental Event identification	366
6.4.5	Critical Controls identification	366
6.4.6	Mitigation measures	366
6.4.7	Risk Ranking	368
6.4.8	ALARP demonstration.....	369
6.4.9	Acceptability demonstration	374
6.5	Environmental impacts of oil spill response.....	377
6.5.1	Hazard report.....	377
6.5.2	Description of hazard.....	379
6.5.3	Impact assessment	380



6.5.4	Control measures.....	404
6.5.5	ALARP demonstration.....	404
6.5.6	Acceptability demonstration	406
6.6	Diesel spill to sea	407
6.6.1	Hazard report.....	407
6.6.2	Description of hazard.....	409
6.6.3	Impact assessment	410
6.6.4	Oil spill response strategies (mitigation)	412
6.6.5	Risk ranking.....	414
6.6.6	ALARP demonstration.....	414
6.6.7	Acceptability demonstration	416
6.7	Discharge of PFW and ballast water from Facility.....	417
6.7.1	Hazard report.....	417
6.7.2	Description of hazard.....	420
6.7.3	Impact assessment	425
6.7.4	Field monitoring of PFW	430
6.7.5	Impact of PFW	433
6.7.6	PFW and ballast water management.....	444
6.7.7	Risk ranking.....	453
6.7.8	ALARP demonstration.....	453
6.7.9	Acceptability demonstration	459
6.8	Introduction of invasive marine pests.....	460
6.8.1	Hazard report.....	460
6.8.2	Description of hazard.....	463
6.8.3	Impact assessment	464
6.8.4	Risk ranking.....	466
6.8.5	ALARP and acceptability demonstration	466
6.9	Non-hazardous and hazardous waste	468
6.9.1	Hazard report.....	468
6.9.2	Description of hazard.....	471
6.9.3	Impact assessment	472
6.9.4	Risk ranking.....	473
6.9.5	ALARP and acceptability demonstration	473
6.10	Use and discharge of chemicals for maintenance and inspection activities	474
6.10.1	Hazard report.....	474
6.10.2	Description of hazard.....	477
6.10.3	Impact assessment	478
6.10.4	Risk ranking.....	479
6.10.5	ALARP and acceptability demonstration	480
6.11	Noise.....	481



6.11.1	Hazard report.....	481
6.11.2	Description of hazard.....	483
6.11.3	Impact assessment	484
6.11.4	Risk ranking.....	488
6.11.5	ALARP and acceptability demonstration	488
6.12	Atmospheric emissions.....	489
6.12.1	Hazard report.....	489
6.12.2	Description of hazard.....	493
6.12.3	Impact assessment	496
6.12.4	Risk ranking.....	497
6.12.5	ALARP and acceptability demonstration	497
6.13	Artificial light	499
6.13.1	Hazard report.....	499
6.13.2	Description of hazard.....	501
6.13.3	Impact assessment	501
6.13.4	Risk ranking.....	502
6.13.5	ALARP and acceptability demonstration	502
6.14	Discharge of cooling water from Facility	503
6.14.1	Hazard report.....	503
6.14.2	Description of hazard.....	505
6.14.3	Impact assessment	505
6.14.4	Risk ranking.....	507
6.14.5	ALARP and acceptability demonstration	507
6.15	Vessel and Facility deck drainage and vessel bilge water discharge	508
6.15.1	Hazard report.....	508
6.15.2	Description of hazard.....	511
6.15.3	Impact assessment	511
6.15.4	Risk ranking.....	512
6.15.5	ALARP and acceptability demonstration	512
6.16	Discharge of sewage, greywater and putrescible waste from Facility and vessels.....	514
6.16.1	Hazard report.....	514
6.16.2	Description of hazard.....	517
6.16.3	Impact assessment	517
6.16.4	Risk ranking.....	519
6.16.5	ALARP and acceptability demonstration	519
6.17	Discharge of desalination brine	520
6.17.1	Hazard report.....	520
6.17.2	Description of hazard.....	521
6.17.3	Impact assessment	521
6.17.4	Risk ranking.....	522



6.17.5	ALARP and acceptability demonstration	522
6.18	Disturbance to marine fauna and seabirds	523
6.18.1	Hazard report.....	523
6.18.2	Description of hazard.....	525
6.18.3	Impact assessment	525
6.18.4	Risk ranking.....	526
6.18.5	ALARP and acceptability demonstration	526
6.19	Liquid hydrocarbon release from topsides process	527
6.19.1	Hazard report.....	527
6.19.2	Description of hazard.....	531
6.19.3	Impact assessment	531
6.19.4	Oil spill response strategies (mitigation)	531
6.19.5	Risk ranking.....	531
6.19.6	ALARP and acceptability demonstration	531
6.20	Ancillary hydrocarbon or chemical spills	534
6.20.1	Hazard report.....	534
6.20.2	Description of hazard.....	537
6.20.3	Impact assessment	537
6.20.4	Risk ranking.....	538
6.20.5	ALARP and acceptability demonstration	538
6.21	Physical presence of infrastructure	540
6.21.1	Hazard report.....	540
6.21.2	Description of hazard.....	543
6.21.3	Impact assessment	543
6.21.4	Risk ranking.....	545
6.21.5	ALARP and acceptability demonstration	546
6.22	Seabed disturbance	549
6.22.1	Hazard report.....	549
6.22.2	Description of hazard.....	551
6.22.3	Impact assessment	551
6.22.4	Risk ranking.....	552
6.22.5	ALARP and acceptability demonstration	552
6.23	Liquid hydrocarbon release from flow lines and risers	553
6.23.1	Hazard report.....	553
6.23.2	Description of hazard.....	557
6.23.3	Impact assessment	557
6.23.4	Oil spill response strategies (mitigation)	558
6.23.5	Risk ranking.....	558
6.23.6	ALARP demonstration.....	558
6.23.7	Acceptability demonstration	559



7.	Implementation strategy.....	561
7.1	Overview.....	561
7.2	HSE management system.....	562
7.2.1	Overview.....	562
7.2.2	Structure.....	562
7.2.3	Policy.....	562
7.2.4	Contents.....	563
7.2.5	Review of the HSE MS.....	565
7.3	Contractor management.....	565
7.4	Key roles and responsibilities.....	566
7.5	Training and competency.....	570
7.5.1	Induction.....	570
7.6	Implementation of performance standards.....	571
7.6.1	Overview.....	571
7.6.2	Wandoo Facility EP commitment register.....	571
7.7	Management of performance deviations.....	571
7.8	Management of change.....	574
7.8.1	Overview.....	574
7.8.2	Process.....	574
7.8.3	Regulatory compliance.....	575
7.8.4	Continuous improvement.....	576
7.9	Emergency management.....	577
7.9.1	Wandoo Emergency Response Plan.....	577
7.9.2	Source Control Plans.....	577
7.10	Oil Pollution Response.....	578
7.10.1	Overview.....	578
7.10.2	Spill Management Arrangements.....	580
7.10.3	Interface with other plans.....	582
7.10.4	Approach to response planning.....	585
7.10.5	Incident management process.....	590
7.10.6	Logistics Management Plan.....	599
7.10.7	Assurance and capability management.....	606
7.11	Chemical assessment process.....	613
7.12	Biofouling risk assessment process.....	615
7.13	Monitoring and Review.....	616
7.13.1	Auditing.....	616
7.13.2	Environmental monitoring strategy.....	617



7.13.3	Review of the Environment Plan and Oil Spill Contingency Plan	621
7.13.4	Annual performance review	622
7.14	Management of asset and decommissioning.....	622
7.14.1	Asset management	622
7.14.2	Managing decommissioning strategy	624
8.	Reporting.....	626
8.1	Routine reports.....	626
8.1.1	Statutory reporting	626
8.1.2	Routine internal reporting	627
8.1.3	Routine external reporting	627
8.2	Internal incident reporting	628
8.3	External incident reporting.....	628
8.3.1	Reportable incidents.....	628
8.3.2	Recordable incidents	629
8.3.3	Management of non-conformances	629
9.	Stakeholder consultation	631
9.1	Introduction.....	631
9.2	Objectives	631
9.3	Stakeholder identification and classification.....	631
9.3.1	Overview	631
9.3.2	Relevant Stakeholders	632
9.4	Stakeholder engagement process and EP update.....	635
9.5	Summary of stakeholder consultation	637
9.5.1	Historic stakeholder engagement.....	637
9.5.2	Current stakeholder engagement.....	637
9.5.3	Ongoing stakeholder consultation.....	651
	References	652
	APPENDICES.....	671
	Appendix 1: Compliance with Divisions 2.2A and 2.3 of the OPGGS(E)R	
	Appendix 2: VOGA Health, Safety and Environment (HSE) Policy	
	Appendix 3: Oil Spill Characteristics and Trajectory Modelling	
	Appendix 4: PFW Composition and Modelling	
	Appendix 5: Performance Standards	
	Appendix 6: Protected Matters Searches	



Abbreviations and definitions

°C	degrees Centigrade
AC	Alternating Current
AFFF	Aqueous Film Forming Foam
AFMA	Australian Fisheries Management Authority
AFU	Air Flotation Unit
AFZ	Australian Fishing Zone
AHTS	Anchor Handling Transport Supply
AHU	Air Handling Unit
AIS	Automatic Identification System
ALARP	As Low as Reasonably Practicable
AMOSC	Australian Marine Oil Spill Centre
AMSA	Australian Maritime Safety Authority
ANZECC	Australian and New Zealand Environment and Conservation Council
APASA	Asia-Pacific ASA
API	American Petroleum Institute
APPEA	Australian Petroleum Production and Exploration Association
ARMCANZ	Agriculture and Resources Management Council of Australia and New Zealand
ASTM	American Society for Testing and Materials
AusSAR	Australian Search and Rescue
AUV	Autonomous Underwater Vehicle
bbl	Barrels
BOM	Bureau of Meteorology
Bonn Convention	Convention on the Conservation of Migratory Species of Wild Animals 1979
BOP	Blowout Preventer
Bq	Becquerel
CALM Buoy	Catenary Anchor Leg Mooring Buoy
CAMBA	Chinese Australia Migratory Birds Agreement
CCR	Central Control Room
CEE	Catastrophic Environmental Event
CFEA	Credible Fire and Explosion Analysis
CFT	Critical Function Test
CFU	Compact Flotation Unit
CGS	Concrete Gravity Structure
CHARM	Chemical Hazard and Risk Management
CP	Cathodic Potential
cSt	centi Stokes

CT	Coiled Tubing
CTD	Conductivity, Temperature and Depth
DAWE	Department of Agriculture, Water and the Environment
dB	decibels
DC	Direct Current
DEC	Department of Environment and Conservation
DWER	Department of Water and Environmental Regulation
DEWHA	Department of Environment, Water, Heritage and the Arts (now Department of Agriculture, Water and the Environment)
DMIRS	Department of Mines, Industry Regulation and Safety (formerly DMP)
DoF	Department of Fisheries
DoIR	Department of Industry and Resources
DoT	Department of Transport
DBCA	Department of Biodiversity, Conservation and Attractions (formerly DPaW)
DRA	Deviation Risk Assessment
DSEWPaC	Department of Sustainability, Environment, Water, Population and Communities (now Department of Agriculture, Water and the Environment)
DTA	Direct Toxicity Assessment
EL	Electric Line
EMBA	Environment that May Be Affected
EP	Environment Plan
EPA	Environmental Protection Authority
EPBC Act	Environment Protection and Biodiversity Conservation Act 1999
EPIP Act	Environment Protection Impact of Proposals Act 1974
ERP	Emergency Response Plan
ESD	Emergency Shutdown
ESDV	Emergency Shutdown Valve
ESP	Electrical Submersible Pumps
F&G	Fire and Gas
FHA	Floating Hose Assembly
FMD	Flooded Member Detection
FPSO	Floating Production, Storage and Offloading
FSO	Floating Storage and Offloading
g/mL	grams per millilitre
GHG	Global Greenhouse Gas
GLC	Gas Lift Compressor
GLV	Gas Lift Valve
HAZOP	Hazard and Operability Study
HFO	Heavy Fuel Oil
HQ	Hazard Quotient



HSE	Health, Safety and Environment
HSES	Health Safety, Environment and Security
HSE MS	Health, Safety and Environment Management System
HV	High Voltage
HVAC	Heating, Ventilation and Air Conditioning
HWO	Hydraulic Workover
Hz, kHz	hertz, kilohertz
IAP	Incident Action Plan
IBC	Intermediate Bulk Container
IC	Incident Commander
ICT	Incident Command Team
ID	Inner Diameter
ISO	International Organization for Standardisation
ISFU	Inducted Static Flotation Unit
IWC	International Whaling Commission
JAMBA	Japan Australia Migratory Birds Agreement
JSA	Job Safety Analysis
KCl	potassium chloride
KEF	Key Ecological Feature
kg	kilogram
km, km/hr	kilometre, kilometres per hour
kPa	kilopascals
KPI	Key Performance Indicator
L	litre
LAT	Lowest Astronomical Tide
LNG	Liquefied Natural Gas
LOEC	Lowest Observed Effect Concentration
LOR	Limit of Reporting
LP	Low Pressure
LV	Low Voltage
m, m ³ , mm	metre, cubic metre, millimetre
MAE	Major Accident Event
MARPOL	International Convention for the Prevention of Pollution from Ships
MCS	Monitoring and Control System
MIC	Microbiologically Influenced Corrosion
MoC	Management of Change
Mooring master	The suitably qualified person appointed by VOGA to advise and direct the tanker Master and officers on all operations at the Wandoo terminal. VOGA representative to carry out duties under the provisions of these regulations and conditions and gazetted by the Western Australian Department of Marine and Harbours under the Shipping and Pilotage Act 1967.



MODU	Mobile Offshore Drilling Unit
MOU	Memorandum of Understanding
MSL	Mean Sea Level
NATA	National Association of Testing Authorities
SIMA	Net Environmental Benefit Analysis
NES	National Environmental Significance
NGER Act	National Greenhouse and Energy Reporting Act 2007
nm	nautical miles
NOEC	No Observed Effect Concentration
NOPSEMA	National Offshore Petroleum Safety and Environmental Management Authority
NORM	Naturally Occurring Radioactive Material
NPI	National Pollutant Inventory
NWS	North West Shelf
OCNS	Offshore Chemical Notification Scheme
OD	Outer Diameter
ODS	Ozone Depleting Substances
OHSAS	Occupational Health and Safety Assessment Series
OIW	Oil in Water
OPEP	Oil Pollution Emergency Plan
OPGGSA	Offshore Petroleum and Greenhouse Gas Storage Act 2006
OPGG(E)R	Offshore Petroleum and Greenhouse Gas Storage (Environment) Regulations 2009
OPP	Oil Pollution Plan
OPRC 90	Convention on Oil Pollution Preparedness, Response and Cooperation 1990
OSCA	Oil Spill Control Agents (Register)
OSCP	Oil Spill Contingency Plan
OSPAR	Oslo and Paris Conventions
OSRL	Oil Spill Response Ltd
OSTM	Oil Spill Trajectory Modelling
P(SL)A	State Petroleum (Submerged Lands) Act
PA	Public Address
PAH	Polycyclic Aromatic Hydrocarbon
PDG	Permanent Down-hole Gauge
PDU	Product Distribution Unit
PFW	Produced Formation Water
PLEM	Pipelines End Manifold
PLONOR	Pose Little or No Risk to the Environment
PMSD	Protected Matters Search Database
PPE	Personal Protective Equipment
ppm	parts per million



PSD	Process Shutdown
PWTS	Produced Water Treatment System
ROKAMBA	Republic of Korea Australia Migratory Bird Agreement
ROV	Remotely Operated Vehicle
RSDV	Riser Shutdown Valves
RT	Rotary Table
scf	standard cubic feet
SDS	Safety Data Sheets
SDV	Shutdown Valve
SES	State Emergency Service
SHA	Submarine Hose Assembly
SIMOPS	Simultaneous Operations
SL	Slick Line
SMPEP	Shipboard Marine Pollution Emergency Plan
SOPEP	Shipboard Oil Pollution Emergency Plan
SOUV	Statement of Outstanding Universal Value
SPM	Single Point Mooring
SSSV	Sub-Surface Safety Valve
t	tonne
TD	total depth
THPS	Tetrakis (hydroxymethyl) phosphonium sulphate
TIE	Toxicity Identification Evaluation
TMS	Tether Management System
TOC	Total Organic Carbon
ToR	Terms of Reference
TPH	Total Petroleum Hydrocarbon
TR	Temporary Refuge
TRFC	Tubing Retrievable Flow Control
TRH	Total Recoverable Hydrocarbons
TSS	Total Suspended Solids
TVD	True Vertical Depth
µg	Micro-grams
UHF	Ultra-High Frequency
UPS	Uninterruptible Power Supply
VDU	Visual Display Unit
VHF	Very High Frequency
VOGA	Vermilion Oil & Gas Australia Pty Ltd
WA	Western Australia
WAF	Water Accommodated Fraction

WAFIC	Western Australian Fishing Industry Council
WAV	Wellhead Actuated Valve
WET	Whole Effluent Toxicity
WestPlan	WA Marine Pollution Contingency Plan
WHA	World Heritage Area
WNA	Wandoo A
WNB	Wandoo B

1. Introduction

1.1 Background

Vermilion Oil & Gas Australia Pty Ltd (VOGA) is the licensed permit holder of production licence area WA-14L, which contains the Wandoo Production Facility (Wandoo Facility). The Permit Area is located within Commonwealth waters in the Carnarvon Basin off the northwest coast of Western Australia (WA), approximately 80km northwest of Dampier and 110km northeast of Barrow Island.

VOGA has been operating in the Permit Area since 2005. This Environment Plan (EP) applies to the operation of the Wandoo Facility (the activity), comprising:

- Wandoo A (unmanned monopod; WNA) where oil is produced, and transported through a flowline to the Wandoo B (WNB) platform;
- Two subsea flexible flow lines connect the oil storage facility [Concrete Gravity Structure (CGS)] at WNB to a Catenary Anchor Leg Mooring (CALM) Buoy;
- A floating hose to transfer the oil from the CALM Buoy to export tankers moored to the CALM Buoy; and
- Supply vessels, work vessels and helicopters supporting, facility logistics, maintenance and provisioning within the field.

The activities undertaken at the Wandoo Facility are further discussed in Section 2.

1.2 Environment Plan Summary

An EP summary will be prepared based on the material provided in this EP. Table 1-1 summarises the content that will be provided within the EP summary, as required by Regulation 11(4) of the OPGGS(E)R.

Table 1-1: EP summary requirements

EP Summary material requirement	Relevant section of this EP containing EP Summary material
The location of the activity	Section 2.2
A description of the receiving environment	Section 4
A description of the activity	Section 2
Details of the environmental impacts and risks	Section 6
The control measures for the activity	Section 6
The arrangements for ongoing monitoring of the titleholder's environmental performance	Section 7.13
Response arrangements in the oil pollution emergency plan	Section 7.10 Oil Pollution Emergency Plan (WAN-2000-RD-0001.02) included with EP submission
Consultation already undertaken and plans for ongoing consultation	Section 9

EP Summary material requirement	Relevant section of this EP containing EP Summary material
Details of the titleholders nominated liaison person for the activity	Section 1.3

1.3 The Proponent

VOGA is the titleholder of production licence WA-14-L, which contains the Wandoo Production Facilities (WPF). VOGA is a wholly owned subsidiary of Vermilion Energy Inc., a Canadian-based oil and gas exploration and production company. VOGA acquired operatorship of the permit at the beginning of 2005 after purchasing the share of the permit from the previous operator, ExxonMobil.

VOGA titleholder details are:

Bruce Lake

Managing Director
 Vermilion Oil & Gas Australia Pty Ltd
 Australian Company Number (ACN): 113 023 591
 Level 5, 30 The Esplanade
 Perth, Western Australia 6000
 Phone: +61 (08) 9215 0300
 Fax: +61 (08) 9215 0333
 Email: info.australia@vermilionenergy.com

VOGA's titleholder nominated liaison person details are:

Namek Jivan

Health, Safety & Environment Manager
 Level 5, 30 The Esplanade
 Perth, Western Australia 6000
 Phone: +61 (08) 9215 0300
 Fax: +61 (08) 9215 0333
 Email: voga.environment@vermilionenergy.com

1.4 Scope and purpose of the Environment Plan

1.4.1 Scope and Purpose

The purpose of this EP is to document the potential environmental impacts and risks and planned mitigation measures associated with the operation of the Wandoo facilities. This EP is limited to the hydrocarbon well production, process, storage and export activities, and supporting operations and maintenance activities conducted within the Permit Area (WA-14L).

The activities covered in this EP include platform-based well activities not utilising a drilling rig (well intervention, de-completion, side-tracking and recompletion) associated with existing and future wells.

The Operational Area (also termed the Wandoo Field) for the activities outlined in Section 2 of this EP is defined as the area within the existing Petroleum Safety Zone (PSZ) within the Permit Area of WA-14-L around the Wandoo facility infrastructure.

Activities excluded from the scope of this EP are:

- Development or exploration drilling activities;
- Vessel operations within Port Boundaries or State waters given they are managed under the Shipping and Pilotage Act 1967 (WA) as administered by the relevant Port Authority under the Port Authorities Act 1999 (WA);
- Vessel operations within Commonwealth waters outside of the Operational Area given they are managed under the Navigation Act 2012 as administered by the Australian Maritime Safety Authority (AMSA); and
- Aviation activities given they are managed under the Civil Aviation Act 1988 and Civil Aviation Regulation 1998 as administered by the Australian Civil Aviation Safety Authority (CASA).

The EP details the arrangements in place for ensuring that the potential environmental impacts and risks associated with well construction activities are reduced to As Low As Reasonably Practicable (ALARP) and are of an acceptable level.

This EP has been prepared in accordance with requirements of the *Offshore Petroleum Greenhouse Gas Storage (Environment) Regulations 2009* (OPGGs[E]R).

The implementation strategy contained in this EP will ensure that operations comply with all statutory requirements and the requirements of the VOGA Health, Safety and Environment Management System (HSE MS). The EP has been prepared to address Wandoo operational activities for the next five years. The Health, Safety and Environment (HSE) Manager is responsible for distributing it to relevant parties, i.e. contractors and NOPSEMA.

VOGA regularly maintain and update the EP as required based on operational needs and activities. All changes that impact the EP will trigger a review to determine if a formal revision is required. Any significant departure from the activity, environment, risks, control measures etc. detailed in the EP, will be identified, and revision and resubmission of the EP will be carried out in accordance with Regulation 17 of the OPGGS(E)R.

Appendix 1 illustrates how this EP addresses each of the key requirements for the content of an EP ensuring fulfilment of Divisions 2.2A and 2.3 of the OPGGS(E)R.

1.4.2 This revision

This revision of the Wandoo Facility EP constitutes a resubmission under sub-regulation 17(5) of the OPGGS(E) Regulations 2009, triggered by a proposed change to produced formation water discharge volumes.

This EP constitutes a five-yearly revision and resubmission under sub-regulation 19 of the OPGGS(E) Regulations 2009.

1.5 Corporate environmental performance philosophy

VOGA is committed to minimising the adverse environmental impacts of its operations and to meeting all regulatory requirements associated with those operations. As stated in the Company Health, Safety and Environment (HSE) Policy, VOGA will:

- accept responsibility and accountability for providing leadership, visible commitment, direction and resources to meet HSE performance targets;
- maintain a strong HSE MS to identify and manage risks;
- integrate HSE into business objectives;
- make a positive contribution to the protection of the environment in which it operates;
- respond promptly and effectively to emergencies;
- focus on continual improvement in HSE performance; and
- communicate openly and fairly on a timely basis with fellow employees and contractors, the public, governments, management and other stakeholders.

A copy of the VOGA HSE Policy is included in Appendix 2.

1.6 Applicable legislation and codes

1.6.1 Overview

This section details the requirements that apply to the activity including relevant legislation, codes, other approvals and conditions. The Commonwealth Offshore Petroleum and Greenhouse Gas Storage Act 2006 (OPGGSA) controls petroleum activities. The OPGGS(E)R stipulates the requirements for EPs to ensure that petroleum activities are carried out in an acceptable manner. VOGA carries out a review of applicable legislation each year.

The Operational Area lies within Commonwealth waters. Commonwealth legislation and other requirements relevant to the activity area including relevant international conventions are described in Table 1-2.

This EP considers the impacts to matters of national environmental significance (MNES) protected under Part 3 of the Environment Protection and Biodiversity Conservation Act 1999 (EPBC Act). Table 1-3 summarises relevant species conservation advices and recovery plans used by the Department of Agriculture, Water and the Environment (DAWE).

1.6.2 Western Australian legislation

Whilst the scope of this activity is limited to the Operational Area within Australian Commonwealth waters, there are State legislative requirements relevant to potential oil spill response activities in State jurisdiction.

Table 1-4 summarises the principal Western Australian legislative requirements relevant to spill response activities in State jurisdiction.

1.6.3 Codes of Practice

The Australian Petroleum Production and Exploration Association (APPEA) Code of Environmental Practice is the most relevant Code of Practice for operating the Facility. Specific requirements of the APPEA Code of Environmental Practice include:

- Compliance with applicable laws, regulations, standards and guidelines, and in their absence, adopting the most practical means to prevent or minimise adverse environmental impacts;
- Ensuring that adequate waste management practices are carried out based on the prevention, minimisation, recycling, treatment and disposal of wastes;
- Providing adequate training to enable employees and contractors to adopt environmentally responsible work practices;
- Developing emergency plans and procedures so that incidents can be responded to in a timely and effective manner; and
- Developing and maintaining management systems to identify, control and monitor risks.

Vermilion is an APPEA member and, when undertaking its projects and activities, adheres to the provisions of its Code of Environmental Practice.

Additionally, the International Finance Corporation (IFC) Environmental, Health, and Safety (EHS) Guidelines (June 2015) are technical reference documents with general and industry-specific examples of Good International Industry Practice (GIIP).

Both the APPEA Code of Environmental Practice and the IFC Environmental, Health, and Safety Guidelines were key references in preparing for the environmental risk assessment process associated with this EP and in the development of the performance outcomes contained within it.



Table 1-2: Relevant Commonwealth Legislation

Legislation	Scope	Related International Conventions	Administering Authority
<i>Australian Maritime Safety Authority Act 1990</i>	<p>This Act facilitates international cooperation and mutual assistance in preparing and responding to a major oil spill incident and encourages countries to develop and maintain an adequate capability to deal with oil pollution emergencies.</p> <p>Requirements are affected through AMSA who administers the National Plan for Maritime Environmental Emergencies (NatPlan).</p> <p>Application to activity: AMSA is the designated Control Agency for oil spills from vessels in Commonwealth waters.</p>	<p>International Convention on Oil Pollution Preparedness, Response and Cooperation 1990</p> <p>Protocol on Preparedness, Response and Co-operation to Pollution Incidents by Hazardous and Noxious Substances, 2000</p> <p>International Convention Relating to Intervention on the High Seas in Cases of Oil Pollution Casualties 1969</p> <p>Articles 198 and 221 of the United Nations Convention on the Law of the Sea 1982</p>	Australian Maritime Safety Authority (AMSA)
Australian Ballast Water Management Requirements (DAWR, 2017)	<p>The Australian Ballast Water Management Requirements set out the obligations on vessel operators with regards to the management of ballast water and ballast tank sediment when operating within Australian seas.</p> <p>Application to activity: Provides requirements on how vessel operators should manage ballast water when operating within Australian seas to comply with the Biosecurity Act 2015.</p>	International Convention for the Control and Management of Ships' Ballast Water and Sediments (adopted in principle in 2004 and in force on 8 September 2017)	Department of Agriculture, Water and the Environment (DAWE)
<i>Biosecurity Act 2015</i> Biosecurity Regulations 2016	<p>This Act replaced the Quarantine Act 1908 in 2015 and is the primary legislation for the management of the risk of diseases and pests that may cause harm to human, animal or plant health, the environment and the economy.</p> <p>The objects of this Act are to provide for:</p> <p>(a) managing biosecurity risks; human disease; risks related to ballast water; biosecurity emergencies and human biosecurity emergencies;</p> <p>(b) to give effect to Australia's international rights and obligations, including under the International Health Regulations, the Sanitary and Phytosanitary Agreement and the Biodiversity Convention.</p> <p>Application to activity: The Biosecurity Act and regulations apply to 'Australian territory' which is the airspace over and the coastal seas out to 12 Nm from the coastline.</p> <p>For the activity the Act regulates vessels entering Australian territory regarding ballast water and hull fouling.</p>	International Convention for the Control and Management of Ships' Ballast Water and Sediments (adopted in principle in 2004 and in force on 8 September 2017)	DAWE
<i>Environment Protection and Biodiversity Conservation Act 1999</i> (EPBC Act)	<p>This Act applies to actions that have, will have or are likely to have a significant impact on matters of national environmental or cultural significance.</p> <p>The Act protects Matters of National Environmental Significance (MNES) and provides for a Commonwealth environmental assessment and approval process for actions. There are eight MNES, these being:</p> <ul style="list-style-type: none"> World heritage properties; Ramsar wetlands; Listed Threatened species and communities; Listed Migratory species under international agreements; Nuclear actions; Commonwealth marine environment; Great Barrier Reef Marine Park; and Water trigger for coal seam gas and coal mining developments. <p>Application to activity: Petroleum activities are excluded from within the boundaries of a World Heritage Area (Sub regulation 10A(f)).</p> <p>The activity is not within a World Heritage Area.</p> <p>The EP must describe matters protected under Part 3 of the EPBC Act and assess any impacts and risks to these.</p> <p>Section 4 describes matters protected under Part 3 of the EPBC Act.</p> <p>The EP must assess any actual or potential impacts or risks to MNES from the activity.</p>	<p>1992 Convention on Biological Diversity and 1992 Agenda 21</p> <p>Convention on International Trade in Endangered Species of Wild Fauna and Flora 1973</p> <p>Agreement between the Government and Australia and the Government of Japan for the Protection of Migratory Birds and Birds in Danger of Extinction and their Environment 1974</p> <p>Agreement between the Government and Australia and the Government of the People's Republic of China for the Protection of Migratory Birds and their Environment 1986</p> <p>Agreement between the Government of Australia and the Government of the Republic of Korea on The Protection of Migratory Birds 2006</p> <p>Convention on Wetlands of International Importance especially as Waterfowl Habitat 1971 (Ramsar)</p> <p>International Convention for the Regulation of Whaling 1946</p> <p>Convention on the Conservation of Migratory Species of Wild Animals (Bonn Convention) 1979</p>	DAWE

Legislation	Scope	Related International Conventions	Administering Authority
Environment Protection and Biodiversity Conservation Regulations 2000	Part 8 of the regulations provide distances and actions to be taken when interacting with cetaceans. Application to activity: The interaction requirements are applicable to the activity in the event that a cetacean is sighted.	-	DAWE
<i>Environmental Reform (Consequential Provisions) Act 1999</i>	This Act allowed the transition of legislation from the Environment Protection Impact of Proposals Act (1974) (EPIP Act) to the EPBC Act. The Environmental Reform (Consequential Provisions) Act clarifies that projects approved under the EPIP Act are exempt from being assessed under the EPBC Act. The Wandoo Full Field Development was approved under the EPIP Act.	-	DAWE
<i>Fisheries Management Act 1991</i>	This Act provides for the protection of Australia's offshore commercial fish resources from 3nm to the extent of the Australian Fishing Zone (200nm). There are no fisheries within the Permit Area however there are several within the EMBA.	Fishermen in Commonwealth-managed fisheries will be informed by VOGA (via AMSA) of program activity as required by legislation.	Australian Fisheries Management Authority (AFMA)
National Biofouling Management Guidelines for the Petroleum Production and Exploration Industry 2009	The guidance document provides recommendations for the management of biofouling risks by the petroleum industry. Application to activity: Applying the recommendations within this document and implementing effective biofouling controls can reduce the risk of the introduction of an introduced marine species.	Certain sections of MARPOL International Convention for the Safety of Life at Sea 1974 Convention on the International Regulations for Preventing Collisions at Sea (COLREG) 1972	DAWE
<i>National Greenhouse and Energy Reporting Act 2007</i> (NGER Act) National Greenhouse and Energy Reporting Regulations 2008	This Act introduces a single national reporting framework for the reporting and dissemination of information about the greenhouse gas emissions, greenhouse gas projects, and energy use and production of corporations. Under the NGER Act, businesses who are very large emitters of greenhouse gases will be required by law to measure and report their emissions to the government. National Pollutant Inventory reporting is covered by this Act.	United Nations Framework Convention on Climate Change (UNFCCC) 1992 Vienna Convention for the Protection of the Ozone Layer 1985 and the Montreal Protocol on Substances that Deplete the Ozone Layer 1987	DoEE/Clean Energy Regulator
<i>Navigation Act 2012</i>	This Act regulates ship-related activities and invokes certain requirements of the International Convention for the Prevention of Pollution from Ships (MARPOL 73/78) relating to equipment and construction of ships. Several Marine Orders (MO) are enacted under this Act relating to offshore petroleum activities, including: <ul style="list-style-type: none"> MO 21: Safety of navigation and emergency arrangements. MO 30: Prevention of collisions. MO 31: Vessel surveys and certification. Application to activity: The relevant vessels (according to class) will adhere to the relevant MO regarding navigation and preventing collisions in Commonwealth waters.	Certain sections of MARPOL International Convention for the Safety of Life at Sea 1974 COLREG 1972 United Nations Convention on the Law of the Sea 1982 (UNCLOS)	AMSA
<i>Offshore Petroleum and Greenhouse Gas Storage Act 2006</i> (OPGGs Act) OPGGs(E)R	The Act addresses all licensing, health, safety, environmental and royalty issues for offshore petroleum exploration and development operations extending beyond the three-nautical mile limit. Part 2 of the OPGGS(E)R specifies that an EP must be prepared for any petroleum activity and that activities are undertaken in an ecologically sustainable manner and in accordance with an accepted EP. Application to activity: The OPGGS Act provides the regulatory framework for all offshore petroleum exploration and production activities in Commonwealth waters, to ensure that these activities are carried out: <ul style="list-style-type: none"> Consistent with the principles of ecologically sustainable development as set out in section 3A of the EPBC Act. So that environmental impacts and risks of the activity are reduced to as low as reasonably practicable So that environmental impacts and risks of the activity are of an acceptable level. 		NOPSEMA

Legislation	Scope	Related International Conventions	Administering Authority
<i>Protection of the Sea (Prevention of Pollution from Ships) Act 1983</i>	<p>This Act regulates Australian regulated vessels with respect to ship-related operational activities and invokes certain requirements of the MARPOL Convention relating to discharge of noxious liquid substances, sewage, garbage, air pollution etc.</p> <p>Application to activity: All ships involved in petroleum activities in Australian waters are required to abide to the requirements under this Act. Several MOs are enacted under this Act relating to offshore petroleum activities, including:</p> <ul style="list-style-type: none"> MO 91: Marine Pollution Prevention – Oil. MO 93: Marine Pollution Prevention – Noxious Liquid Substances. MO 94: Marine Pollution Prevention – Packaged Harmful Substances. MO 95: Marine Pollution Prevention – Garbage. MO 96: Marine Pollution Prevention – Sewage. MO 97: Marine Pollution Prevention – Air Pollution. 	<p>Various parts of MARPOL</p> <p>Convention on the Prevention of Marine Pollution by Dumping of Wastes and Other Matter, 1972 (also known as the London Protocol)</p>	AMSA
<i>Protection of the Sea (Harmful Antifouling Systems) Act 2006</i>	<p>Under this Act, it is an offence for a person to engage in negligent conduct that results in a harmful anti-fouling compound being applied to or present on a ship. The Act also provides that Australian ships must hold 'anti-fouling certificates', provided they meet certain criteria.</p> <p>Application to activity: All ships involved in offshore petroleum activities in Australian waters are required to abide to the requirements under this Act.</p> <p>The MO 98: Marine Pollution Prevention – Anti-fouling Systems is enacted under this Act.</p>	International Convention on the Control of Harmful Anti-fouling Systems on Ships 2001	AMSA
<i>Underwater Cultural Heritage Act 2018</i>	<p>Protects the heritage values of shipwrecks, sunken aircraft and relics (older than 75 years) in Australian Territorial waters from the low water mark to the outer edge of the continental shelf (excluding the State's internal waterways). The Act allows for protection through the designation of protection zones. Activities / conduct prohibited within each zone will be specified.</p> <p>Application to activity: In the event of removal, damage or interference to shipwrecks, sunken aircraft or relics declared to be historic under the legislation, activity is proposed with declared protection zones, or there is the discovery of shipwrecks or relics.</p>	Agreement between the Netherlands and Australia concerning old Dutch Shipwrecks 1972	DAWE

Table 1-3: Recovery plans and species conservation advices relevant to the Wandoo Facility Environment Plan

Relevant Plan/Advice	Applicable Threats or Management Advice
National Recovery Plan for Threatened Albatrosses and Giant Petrels 2011–2016 (DSEWPaC, 2011)	The recovery plan is a co-ordinated conservation strategy for albatrosses and giant petrels listed as threatened. Threats: <ul style="list-style-type: none"> • Marine pollution: evaluate risk of oil spill impact to nest locations and, if required, appropriate mitigation measures are implemented. • Marine debris: evaluate risk of marine debris (including risk of entanglement and/or ingestion) and, if required, appropriate mitigation measures are implemented.
Approved Conservation Advice for <i>Sternula nereis</i> (Fairy Tern) (TSSC, 2011)	Conservation advice provides management actions that can be undertaken to ensure conservation of the fairy tern. Threats: <ul style="list-style-type: none"> • Marine pollution: evaluate risk of oil spill impact to nest locations and, if required, appropriate mitigation measures are implemented.
Approved Conservation Advice for <i>Calidris canutus</i> (Red Knot)	Conservation advice provides management actions that can be undertaken to ensure conservation of the red knot. Threats: <ul style="list-style-type: none"> • Marine pollution: evaluate risk of oil spill impact to nest locations and, if required, appropriate mitigation measures are implemented.
Approved Conservation Advice for <i>Calidris tenuirostris</i> (Great knot)	Conservation advice provides management actions that can be undertaken to ensure conservation of the great knot. Threats: <ul style="list-style-type: none"> • Habitat loss and degradation: prevent destruction of key breeding and migratory staging sites. • Marine pollution: evaluate risk of oil spill impact to nest locations and, if required, appropriate mitigation measures are implemented.
Approved Conservation Advice for <i>Calidris fruginea</i> (Curlew sandpiper)	Conservation advice provides management actions that can be undertaken to ensure the conservation of the curlew sandpiper. Threats: <ul style="list-style-type: none"> • Habitat loss and degradation: maintain undisturbed feeding and roosting habitat at sites on the north-west coast used during migration for the species
Approved Conservation Advice for <i>Charadrius mongolus</i> (Lesser sand plover)	Conservation advice provides management actions that can be undertaken to ensure the conservation of the lesser sand plover. Threats: <ul style="list-style-type: none"> • Habitat loss and degradation from pollution, changes to water regimes and invasive plants
Approved Conservation Advice for <i>Ptodroma mollis</i> (soft-plumaged petrel)	Conservation advice provides management actions that can be undertaken to ensure conservation of Abbott's booby. Threats: <ul style="list-style-type: none"> • None applicable
Approved Conservation Advice for <i>Papasula abbotti</i> (Abbott's booby)	Conservation advice provides management actions that can be undertaken to ensure the conservation of Abbott's booby. Threats: <ul style="list-style-type: none"> • Loss of breeding habitat on Christmas Island.
Approved Conservation Advice for <i>Anous tenuirostris melanops</i> (Australian lesser noddy)	Conservation advice provides management actions that can be undertaken to ensure the conservation of the Australian lesser noddy. Threats: <ul style="list-style-type: none"> • Marine pollution: evaluate risk of oil spill impact to nest locations and, if required, appropriate mitigation measures are implemented.
Wildlife Conservation Plan for Migratory Shorebirds (DoE, 2015)	<ul style="list-style-type: none"> • No threats identified.
Approved Conservation Advice for <i>Rhincodon typus</i> (whale shark)	Conservation advice provides management actions that can be undertaken to ensure conservation of the whale shark Threats: <ul style="list-style-type: none"> • Habitat loss and degradation from pollution, changes to water regimes and invasive plants
Recovery Plan for the White Shark (<i>Carcharodon carcharias</i>) (DSEWPaC, 2013)	The overarching objective of this recovery plan is to assist the recovery of the white shark in the wild throughout its range in Australian waters. <ul style="list-style-type: none"> • No Threats identified
Recovery Plan for the Grey Nurse Shark (<i>Carcharias Taurus</i>) west coast population (DoE 2014)	The recovery plan considers the conservation requirements of the grey nurse shark across its range and identifies the actions to be taken to ensure the species long-term viability.
Approved Conservation Advice for <i>Pristis zijsron</i> (green sawfish) Sawfish and River Sharks Multispecies Recovery Plan: (<i>Pristis</i> , <i>Pristis zijsron</i> , <i>Pristis clavata</i> , <i>Glyphis</i> and <i>Glyphis garricki</i>)	Conservation advice provides management actions that can be undertaken to ensure conservation of the green sawfish. Threats: <ul style="list-style-type: none"> • Habitat loss and degradation
Approved Conservation Advice for <i>Pristis clavata</i> (dwarf sawfish) Sawfish and River Sharks Multispecies Recovery Plan: (<i>Pristis pristis</i> , <i>Pristis zijsron</i> , <i>Pristis clavata</i> , <i>Glyphis glyphis</i> and <i>Glyphis garricki</i>)	Conservation advice provides management actions that can be undertaken to ensure the conservation of the dwarf sawfish. Threats: <ul style="list-style-type: none"> • Habitat loss and degradation
Approved Conservation Advice for short-nosed sea snake (<i>Aipysurus praeae</i>)	Conservation advice provides management actions that can be undertaken to ensure the conservation of the short-nosed sea snake. Threats: <ul style="list-style-type: none"> • Degradation of reef habitat: no anthropogenic disturbance in areas where the Short-nosed Sea Snake occurs.

Relevant Plan/Advice	Applicable Threats or Management Advice
Recovery Plan for Marine Turtles in Australia, 2017-2027 (DEE, 2017)	The long-term recovery objective for marine turtles is to minimise anthropogenic threats to allow for the conservation status of marine turtles to improve so that they can be removed from the EPBC Act Threatened species list. Threats: <ul style="list-style-type: none"> • Chemical and terrestrial discharge. • Marine debris. • Light pollution. • Habitat modification. • Vessel strike. • Noise interference. • Vessel disturbance.
Approved Conservation Advice for <i>Dermochelys coriacea</i> (Leatherback Turtle)	See above for Recovery Plan for Marine Turtles in Australia, 2017-2027.
Conservation Management Plan for the Blue Whale, 2015-2025 (DoE, 2015)	The long-term recovery objective for blue whales is to minimise anthropogenic threats to allow for their conservation status to improve so that they can be removed from the EPBC Act threatened species list. Threats: <ul style="list-style-type: none"> • Noise interference: evaluate risk of noise impacts and, if required, appropriate mitigation measures are implemented. • Vessel disturbance: evaluate risk of vessel strikes and, if required, appropriate mitigation measures are implemented.
Approved Conservation Advice for <i>Balaenoptera borealis</i> (Sei Whale)	Conservation advice provides threat abatement activities that can be undertaken to ensure the conservation of the sei whale. Threats: <ul style="list-style-type: none"> • Noise interference: evaluate risk of noise impacts to cetaceans and, if required, appropriate mitigation measures are implemented. • Vessel disturbance: evaluate risk of vessel strikes and, if required, appropriate mitigation measures are implemented.
Approved Conservation Advice for <i>Megaptera novaeangliae</i> (Humpback Whale) (TSSC, 2015)	Conservation advice provides threat abatement activities that can be undertaken to ensure the conservation of the humpback whale. Threats: <ul style="list-style-type: none"> • Noise interference: evaluate risk of noise impacts to cetaceans and, if required, appropriate mitigation measures are implemented. • Vessel disturbance: evaluate risk of vessel strikes and, if required, appropriate mitigation measures are implemented.
Conservation Management Plan for the Southern Right Whale 2011-2021 (DSEWPaC, 2012)	Conservation advice provides threat abatement activities that can be undertaken to ensure the conservation of the Southern right whale. Threats: <ul style="list-style-type: none"> • Noise interference: evaluate risk of noise impacts to cetaceans and, if required, appropriate mitigation measures are implemented. • Vessel disturbance: evaluate risk of vessel strikes and, if required, appropriate mitigation measures are implemented.
Approved Conservation Advice for <i>Balaenoptera physalus</i> (Fin Whale)	Conservation advice provides threat abatement activities that can be undertaken to ensure the conservation of the fin whale. Threats: <ul style="list-style-type: none"> • Noise interference: evaluate risk of noise impacts to cetaceans and, if required, appropriate mitigation measures are implemented. • Vessel disturbance: evaluate risk of vessel strikes and, if required, appropriate mitigation measures are implemented.
Recovery plan for the Australian Sea Lion (<i>Neophoca cinerea</i>)	The long-term recovery objective for the Australian sea lion is to minimise anthropogenic threats to allow for their conservation status to improve so that they can be removed from the EPBC Act threatened species list. Threats: <ul style="list-style-type: none"> • Noise interference: evaluate risk of noise impacts and, if required, appropriate mitigation measures are implemented. • Vessel disturbance: evaluate risk of vessel strikes and, if required, appropriate mitigation measures are implemented.

Table 1-4: Relevant Western Australian Legislation

Legislation	Scope	Application to Activity	Administering Authority
<i>Biodiversity Conservation Act 2016</i>	Provides for the conservation and protection of biodiversity and biodiversity components and the ecologically sustainable use of biodiversity components in Western Australia	Biodiversity Conservation Regulations 2018 sets out separation distances for whale sharks and other marine fauna.	Department of Biodiversity, Conservation and Attractions (DBCA)
<i>Environmental Protection Act 1986</i>	Provides for the prevention, control and abatement of pollution and environmental harm, for the conservation, preservation, protection, enhancement and management of the environment	This Act regulates wastes discharged into the environment	Department of Water and Environmental Regulation (DWER)
<i>Conservation and Land Management Act 1984</i>	This Act provides for the use, protection and management of public lands, including parks and forests. It includes water, flora and fauna on these lands.	The Act may be triggered in the event of a spill that impacts upon a public conservation reserve	DBCA
<i>Fish Resources Management Act 1996</i>	Regulates the management of and utilisation and conservation of fish and their habitat.	Liaison with commercial fishermen. Requires management of IMS risks.	Department of Primary Industries and Regional Development (DPIRD)
<i>Local Government Act 1985</i>	This Act is concerned with the administration of municipalities. It vests local authorities with responsibility for handling domestic and trade wastes, sewage disposal and protection of water sources (channels, pools, dams, etc.) from pollution.	Waste will be disposed of at an onshore facility	Local Government Authority
<i>Marine and Harbours Act 1981</i>	Provides for the advancement of efficient and safe shipping and effective boating and port administration	This Act contains regulations to control the refuelling of ships and boats; administered by the Department of Fisheries.	Department of Fisheries (DoF)
<i>Maritime Archaeology Act 1973</i>	Provides for the preservation of the remains of ships lost before 1900	May be triggered in the event of impacts to a known or previously un-located shipwreck	WA Museum
<i>Pollution of Waters by Oil and Noxious Substances Act 1987</i>	Provides for the protection of the sea from pollution by oil and other noxious substances. Gives effect to MARPOL in state waters.	Triggered in the event of vessels operating in state waters	Department of Transport (DoT) Relevant Port Authority
<i>Western Australian Marine Act 1982</i>	Regulates navigation and shipping	Triggered in the event of vessels operating in state waters	DoT

2. Description of activity

2.1 Overview

The Wandoo Field was discovered in 1991. Extraction of crude oil commenced in 1993 from a single unmanned monopod wellhead platform (Wandoo A) supporting a helideck and five production wells. The Wandoo B production platform and a Concrete Gravity Structure (CGS) with associated processing facilities, were installed in 1997 and connected to Wandoo A by a subsea flowline.

The oil produced from Wandoo A (WNA) is piped to the Wandoo B (WNB) platform. After treatment, the oil is stored in the CGS and then, when sufficient volumes are available, offloaded through flexible flowlines to a Catenary Anchor Leg Mooring Buoy (CALM Buoy) located 1.2 km north of the WNB platform (refer Figure 2-1). A floating hose is used to transfer the oil from the CALM Buoy to export tankers situated at the mooring facility. Export tankers are used to offload the oil. Oil production from the WNB production platform commenced in March 1997 and total field production is currently in the order of 5,000 bbls/day. The end of field life is currently modelled to be approximately 2030.

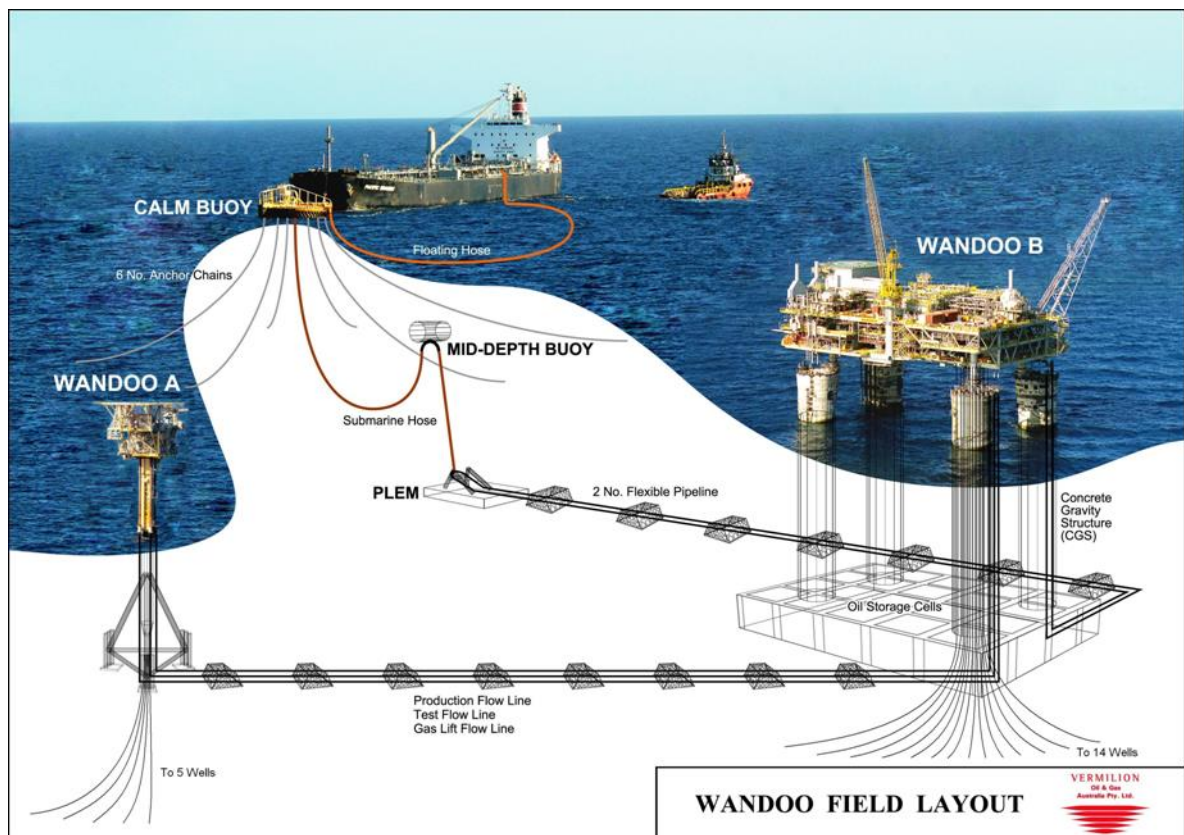

Figure 2-1: The Wandoo oil production facilities

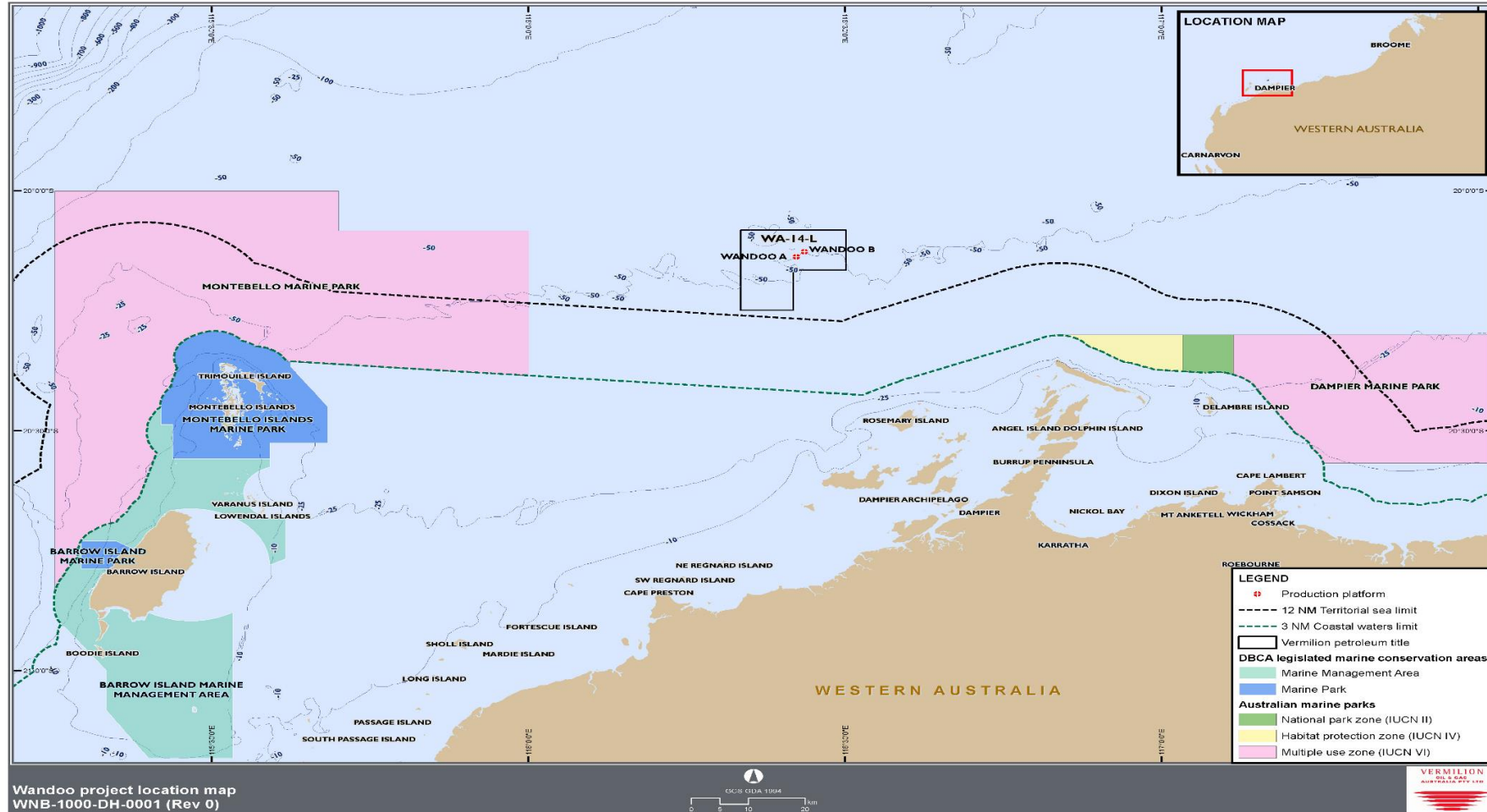

Figure 2-2: Location of the Wandoo Field

2.2 Location

The Wandoo Facilities, including the Wandoo A (WNA) Monopod, Wandoo B (WNB) Platform, CALM Buoy (single-point mooring Tanker Mooring and Offloading Facility) and anchorage are located in production licence area WA-14L, approximately 80 km northwest of Dampier and in water depths of approximately 54m. Geographical coordinates of the various facilities at Wandoo are given in Table 2-1. The location of the Wandoo Field is shown in Figure 2-2.

Table 2-1: Coordinates of Wandoo production facilities

Facility	Latitude	Longitude
Wandoo A (WNA)	20°08' 20" S	116°25' 17.5" E
Wandoo B (WNB)	20°07' 43" S	116°26' 04" E
Anchorage	20°05' 00" S	116°23' 48" E
CALM Buoy	20°07' 02" S	116°26' 02" E

2.3 Reservoir characteristics

Wandoo crude, having lost most of its lighter fractions due to microbial biodegradation in the reservoir, is a 19.4° API crude, and is similar to other medium crude produced on the North-West Shelf (NWS). It has a low pour point, virtually no paraffin wax and low asphaltene content.

Modelling undertaken by RPS for the Wandoo B10 well (RPS, 2020) shows that for Wandoo Crude, approximately 1.7% (by mass) of volatile hydrocarbons, will evaporate within the first 12 hours. A further 10.2% of the oil is characterised as the semi-volatile hydrocarbon compounds and will evaporate within the first 24 hours while an additional 33.1% represent the low volatiles and will typically evaporate over several days. A relatively high proportion (55%) of hydrocarbon compounds is persistent which are unlikely to evaporate and will decay over time.

A summary of reservoir oil specification is contained in Table 2-2 and Table 2-3.

Table 2-2 Physical properties for Wandoo Crude

Properties	Wandoo Crude
Density (kg/m ³)	0.937 (at 16 °C)
API	19.4
Dynamic viscosity (cP)	161 (at 25 °C)
Pour point (°C)	-24
Hydrocarbon property category	Group IV
Hydrocarbon property classification	Persistent

Table 2-3 Boiling point ranges for Wandoo Crude

Characteristic Oil Type	Volatiles (%)	Semi-volatiles (%)	Low Volatiles (%)	Residual (%)
Boiling point (°C)	< 180	180-265	265-380	> 380
	Non persistent			Persistent
Wandoo Crude	1.7	10.2	33.1	55

An understanding of the geology and reservoir characteristics in the Permit Area is an essential element of the EP, as it informs the identification, prevention and response to potential oil spill scenarios arising from the unlikely event of well control incident

Currently, the only producing reservoir in the Wandoo Field is the *M. australis* Sandstone. The *M. australis* Sandstone is subdivided into an upper unit (the A sand) and lower unit (the B sand). The A sand is a fine-grained highly glauconitic sandstone (greensand) with a porosity of approximately 30% and permeability ranging from 50 to 3000 millidarcy (mD) with reservoir characteristics that improve markedly with depth. The A sand is subdivided into three units, the uppermost being the A1 and the lowermost the A3. The B sand is a relatively clean, fine to medium-grained, quartzose sandstone of exceptional reservoir characteristics with porosities ranging from 35% to 40% and permeability ranging from 5 to 15 darcy (D). The B sand is also subdivided based on reservoir quality (B1, B2, etc.).

Both the A and B sands are effectively unconsolidated. An important feature of the A sand is the presence of laterally discontinuous and co-relatable siderite beds. These siderite beds are primarily concentrated in the A2 unit. Due to the unconsolidated nature of the sand and its high glauconite content, drill cuttings from the reservoir do not consist of rock chips and fragments that would otherwise be expected if a harder substrate or more consolidated substrata was drilled. Consequently, cuttings from this reservoir consist essentially of loose grains of sand and dispersed clays rather than rock fragments.

Prior to the start of production, the Field had a 22.1m oil column overlain by an 18m gas column at the crest of the Field. The oil is heavily biodegraded and viscous (19.4 API gravity, 14.5 centiPoise (cP) viscosity, -24°C pour point) and has a low Gas Oil Ratio (GOR) (99 standard cubic feet per barrel (scf/bbl)). The sulphur and wax contents are also low. The Field is currently drained by 20 horizontal wells, with injection of excess gas being carried out through another horizontal well. All wells are drilled from two platforms (WNA and WNB).

Since production began in the mid-1990s, the reservoir has depleted to a flowing pressure of ~5,100kPa (0.89SG). Recent evaluation of shut-in pressure with all wells shut in for a period of two weeks indicated a reservoir pressure of ~5,475kPa (0.95SG). Due to the water drive mechanism that charges the Wandoo reservoir, it is generally understood that over time, the reservoir will recharge to virgin pressure. However, whilst operations are ongoing, the reservoir will continue to exhibit a sub-hydrostatic pressure regime requiring a very high level of under-balance to achieve flow to surface. The reservoir pressure was hydrostatic prior to the commencement of production at Wandoo, over the 18 years of production the pressure has now declined to some 75% of its original state (from 6,900kPa to 5,100kPa).

2.4 Field infrastructure

2.4.1 WNA platform

The WNA platform is a 'normally unattended' wellhead platform that consists of a fixed structure without processing equipment. The substructure is a monopod structure piled to the seabed and the topsides consists of two deck levels. Lower Deck (Wellhead Deck) consists of:

- Five production wellheads and wellhead choke valves.
- Flowline risers and riser shutdown valves.
- Wellhead and Tubing Retrievable Surface Controlled Subsurface Safety Valve (TRSCSSV) control panel, with telemetry system linking back to WNB Central Control Room.

A carrier caisson that contains four risers:

- 323.9mm OD Production riser;
- 219.1mm OD Test riser;
- 114.3mm OD Gas Lift riser; and
- 323.9mm OD Spare Production riser.
- Production header and pig launcher.
- Gas lift header and pig receiver.
- Wellhead control panel.
- Instrument gas system with nitrogen backup (Nitrogen stored on Main Deck).
- Life raft and controlled descent devices.
- Safety equipment.

Note that the test riser and flowline system is currently isolated, and no longer used for hydrocarbon service. It is only used for round trip flushing of the production riser and flowline system using water.

Upper (Main) Deck consists of:

- Platform crane with remote power unit.
- Equipment/personnel shelter (a new combined utility and crib room installed July 2014)
- Helideck.
- Monitoring and control system, including data link to WNB telemetry.
- Potable water tank.
- Laydown area, chemical storage area and nitrogen bulk storage.
- Chemical injection system.
- Radio telemetry system, and navigation aids.
- Power distribution system, including solar panels and batteries.

- Life raft and controlled descent devices.
- Removable hatches for well entry access.

A crane is provided to transfer equipment or supplies from a supply boat and support well intervention operations. The crane is rated for an off-the-boat lift of 7t at 7m radius.

The primary access to the platform is by helicopter.

The platform is accessible by a cantilever jack-up rig, referred to as a mobile offshore drilling unit (MODU). Depending on the well being worked on, the positioning tolerance for the rig might be as small as $\pm 1\text{m}$.

2.4.2 WNB platform

The WNB platform is comprised of a single integrated three-level deck (Main, Mezzanine and Cellar) of rectangular plan, supported at four corners by the CGS shafts. The CGS and the topside facilities are described in the following sections.

2.4.2.1 WNB CGS storage system and shafts

Storage system

The topside facility (at WNB) is supported on four concrete shafts that integrate into a concrete base (the CGS) that is comprised of ballast, product storage and water cells. The CGS sits on the seabed.

- Shaft 1 is located at the northeast corner of the facility and provides a conduit for the original 12 well conductors. Three free standing conductors (one containing WNB 13, one containing WNB 14 and one containing WNB 15 and WNB 16) were installed externally to Shaft 1 in 2008. An additional free-standing conductor is planned to be installed external to Shaft 1 during the term of this EP;
- Shaft 2 is located on the southeast corner of the platform and forms the main diesel storage with a capacity of up $2,500\text{m}^3$ of diesel;
- Shaft 3 is located on the southwest corner and is flooded for ballast with the seawater inlet locked closed; and
- Shaft 4 is located at the northwest corner and contains several internal caissons for oil product storage, ballast water inlet, ballast water pumps, export pumps and interface layer treatment pumps. It is also used for Ballast Water storage.

The CGS has several functional requirements, the most important being to:

- Support the weight and structural design loads of the topside and transfer it to the seabed;
- Provide stabilised crude oil import, storage and export facilities;
- Provide diesel fuel storage facilities; and
- Support flowline risers and well conductors.

The CGS is made of reinforced and post-tensioned concrete. It consists of a rectangular base caisson sitting directly on the seabed with four vertical shafts projecting from the base to support the topsides above sea level. The overall dimensions of the base caisson are 115m long, 70m wide and 17m high. It has a maximum capacity of 430,000bbls (US). It is under negative hydrostatic pressure, therefore, if the integrity of the CGS is affected, seawater will flow into the cells before the oil is able to flow out. The structural integrity of the CGS is managed under the Wandoo Facility Integrity Management System.

Shafts

The four hollow shafts are 11m in outside diameter and stand 52m clear of the top of the base caisson roof, and 15m above LAT (Lowest Astronomical Tide). There are concrete slabs covering the top of each shaft. The shaft walls are thickened locally at the top to accommodate the steel deck connection on each shaft.

Each of the vertical shafts has the same internal diameter of 10.2m with a wall thickness tapering from 575mm to 400mm. Each shaft is locally thickened to 3,500mm at the top to accommodate the deck connections.

Shaft 1

Shaft 1 is located at the northeast corner of the facility and provides conduit for the original 12 well conductors which provide the production to the process. In 2008 three new conductors were installed on the north face of Shaft 1 with guidance provided by a purpose-built integrated conductor guide and protection frame. Risers are located externally to the west face of the shaft for crude oil export (2 of), incoming production and test risers from WNA and a gas lift riser supplying WNA.

Shaft 1 is the drill shaft internally containing:

- 11 production wells; and
- One gas reinjection well.

The steel conductors enclosing the well casings and tubing run vertically in Shaft 1, entering through the base caisson floor slab and exiting through the shaft capping slab so they are effectively isolated from the shaft. The conductors are laterally supported in the shaft at regular intervals by steel guide frames attached to the shaft walls. Shaft 1 is flooded up to mean sea level with an air space between the water level and the shaft capping slab. There is no equipment, lights or sensors within Shaft 1. No provision for human entry is provided for.

On the outside of Shaft 1 are:

- Two oil export risers;
- A gas lift riser and test riser inside a single caisson;
- A production riser;
- Three free standing conductors (one containing WNB 13, one containing WNB 14 and one containing WNB 15 and WNB 16); and

- An additional free-standing conductor with the capability of hosting up to three production wells is planned to be installed during the term of this EP

Note that the test riser and flowline system is currently isolated and preserved and no longer used for hydrocarbon service. The test riser is used for round trip flushing of the production riser and flowline system using water.

Shaft 2

The interior of Shaft 2 is used for diesel storage. The concrete shaft walls and the base caisson top slab are used to contain the diesel.

The diesel is supplied from a 'bunkering' vessel and pumped via a rundown caisson into Shaft 2.

Electrical submerged duty and standby pumps are provided, plus a sump pump. All pumps and instrumentation can be withdrawn through the Shaft 2 roof capping slab. No personnel entry is provided.

The outside of Shaft 2 provides support for a firewater pump caisson and a sewage caisson

Shaft 3

Shaft 3 is located on the southwest corner and is flooded for ballast with the seawater inlet locked closed. Shaft 3 is unutilised and is flooded with seawater up to sea level, with the sea connection locked shut. There is no equipment, lights, sensors etc. in Shaft 3. There is no provision for personnel entry into Shaft 3.

The outside of Shaft 3 provides support for another firewater pump caisson, seawater service pump caissons, and a seawater service outfall

Shaft 4

Shaft 4 is located at the northwest corner and contains several internal caissons for oil product storage, ballast water inlet, ballast water pumps, export pumps and interface layer treatment pumps. Shaft 4 is the utility shaft. It contains the equipment and pipework to import and export crude oil to and from the storage compartments. This crude oil import/export system is outlined in the Process Description. Numerous caissons and pipes are supported on a central steel tower within the shaft.

Shaft 4 is filled with ballast water and maintained to a level approximately 15m below sea level (elevation -15m) to maintain the negative hydrostatic pressure in the oil storage compartments. This level is maintained by the ballast water system which is also described in the Process Description.

- The pressure differential is advantageous to the CGS for the following reasons:
- Localised cracks would result in the ingress of seawater into the storage cells, as opposed to an oil leak into the sea; and
- CGS is maintained in slight compression by external hydrostatic pressure which is advantageous to the life of the concrete structure
- The outside of Shaft 4 supports a produced formation water (PFW) outfall line.

There are 13 caissons that penetrate the Shaft 4 capping slab. All caissons and pipes in which fluids flow are made from glass reinforced epoxy and are supported on a steel tower structure running the full height of the shaft. The electric motors for the shaft driven oil export pumps are located on the Cellar Deck. All other pumps are electrical submerged pumps.

Other penetrations through the slab include equipment hatches, personnel access hatches and the exhaust and supply ducts for the shaft ventilation system.

To minimise the possibility of methane and hydrogen sulphide build up in Shaft 4 vapour space, a forced ventilation system is installed to provide approximately four air changes per hour. Ducted fresh air is supplied and removed from a high elevation near the capping slab and a low elevation above the ballast water level. Hydrogen sulphide, methane and smoke detectors monitor the extracted air.

2.4.2.2 *Base caisson*

The rectangular caisson base is subdivided by internal walls into 60 cells each measuring 11.25m by 11.25m in plan. There are 16 perimeter cells that are open, having no top slab and are filled with rock ballast. A further four cells are filled with water ballast.

There are two large oil storage compartments in the base caisson:

- The smaller consists of 16 interconnected cells; and
- The larger compartment is made from one main group of 16 cells and two smaller groups of four cells each.

The internal walls are 350mm thick and have penetrations to allow the cells groups to interconnect while forming two independent compartments. The perimeter walls of the two compartments resist hydrostatic forces and are nominally 875mm thick but are thickened to 1425mm at the cross-wall locations.

The depth of the base caisson floor slab varies between 720mm and 845mm; the top slab has a constant thickness of 776mm. A series of base drain strips are cast onto the bottom of the floor slab to permit the dissipation of any excess pore water pressures in the soil. All the base caisson walls are post-tensioned. The roof slab is post-tensioned in the shorter direction only and the shafts are post-tensioned vertically. The base slab is not post-tensioned.

All four sides of the CGS have scour protection with graded iron ore used both for ballasting of the CGS and for scour protection. The scour protection is 10m wide by 1.5m deep.

2.4.2.3 *WNB topsides*

The WNB platform orientation is true north. The principle features of the platform are shown below in Table 2-4.

Table 2-4: Platform principal features

Features	Nominal specifications
Slots	14 slots for production wells and one slot for gas reinjection.
Plans	Dimensions of approx. 69m x 40m; plus 3.7m x 10m for the planned wellbay extension.
Deck area	Total deck area to support process and utility equipment of approx. 7,600m ² , plus additional 37m ² for the planned wellbay extension.
Planned deck extension	A new deck extension is planned to accommodate a new conductor and up to 3 new production wells. The deck area for this planned extension is 37 m ²
Trusses	Two 10m deep trusses (TA and TB) spanning approx. 51m in the N-S direction. Seven 10m deep trusses (T1 to T7) spanning approx. 25m in the E-W direction.
Passive fire protection	Passive fire protection to the main truss steelwork, north of the firewall.
Dry and operating weights	Dry and operating weights of 6,731t and approx. 10,000t respectively (Existing wellbay extension added 22t). (The new planned deck extension will add 61t)
Deck height	Height between each deck level of 5.0m.
Accommodation	WNB living quarters comprise a total of 59 beds.

The underside of Cellar Deck primary steel is set at an elevation of +21.0m to provide an air gap to the crest of the 100-year return period for extreme weather cyclonic waves.

Primary access to the platform is by helicopter. The helideck is located on top of the accommodation module.

One pedestal crane is provided for top deck materials handling and transfer of equipment and supplies from a supply vessel, and for other platform activities (e.g. to support construction activities on the platform). This crane also enables some work basket activities to be conducted over the side. The equipment and facilities provided on each of the three WNB decks are listed in Table 2-5 to Table 2-8.

The Main Deck has been designed to take impact loads from a defined object weight and drop height. All the main process equipment has been located away from the main lifting zones. The subsea flow lines and risers are also located away from the main lifting zones.

There is swinging load protection in the form of crash barriers around the south and west faces of the Main Deck laydown area, and around the north, south and west faces of the other Main Deck laydown area. No protections were required on the Cellar Deck laydown area where diesel filters are located.

Table 2-5: Equipment and facilities on the WNB Main Deck

WNB Main Deck	
North End	Flare boom (northwest side)
	Space above the CGS Shaft 1 and Mezzanine Deck wellhead area for well intervention operations (northeast side)
	Laydown area including extended deck for existing wellbay extension and planned extension
	Gas lift compression and treatment

WNB Main Deck	
	Recovered gas compression
	Fuel gas treatment
	Fuel gas filters
	Chemical injection and storage
Central Area	Production separators (two)
	Hydrocyclones (two)
	Second stage and test separators
	Chemical injection and storage facilities
	Platform crane (east side)
	Nitrogen generator package
South End	Cooling and heating medium equipment and tanks
	Electro-chlorination unit
	Air compressor packages
	Platform power generation units gas turbines
	Accommodation
	Food storage freezer and PLQ Extension Heating, Ventilation and Air Conditioning (HVAC)
	Helideck above accommodation module (southwest corner)

Table 2-6: Equipment and facilities on the WNB Mezzanine Deck

WNB Mezzanine Deck	
North End	Wellheads, Xmas trees, existing wellbay extension and planned wellbay extension
	Production, test and gas lift manifolds
	Pig launchers and receivers and process heat exchanges
South End (south of the blast wall)	Platform HVAC plant
	High voltage switch gear room
	Platform workshops, storage and laboratory
	Temporary refuge area comprising of: <ul style="list-style-type: none"> • Muster area; • Control room and telecommunications room; and • Instrument equipment room low voltage (LV) switch gear
	Instrument equipment room
	Uninterruptible power supply systems
	LV switchgear room

Table 2-7: Equipment and facilities on the WNB Cellar Deck

WNB Cellar Deck	
North End	Oil export facilities
	Production rundown headers

WNB Cellar Deck	
	Ballast water facilities
	Interface layer facilities
	Flare knock out drum
	Metering skid
	Infield risers with associated emergency shutdown valves
Central Area	Production coalescers and rundown metering
	Produced Water Treatment System (PWTS) including Degasser, Recovered Oil Tank, Recovered Oil Vessel, ISFU1 and ISFU2
	Platform diesel storage in crane pedestal (east side)
South End (south of the blast wall)	Seawater lift pumps and filters
	Reverse osmosis unit
	Diesel fuel treatment package
	Firewater pumps
	Firewater deluge manifold and firewater ring main
	Aqueous film forming foam package
	Emergency generator package
	2 x Temporary Safety Craft and 1 x Wandoo Recovery Craft (extreme south end)
Cooling medium exchangers	

Table 2-8: Equipment and facilities below the WNB Cellar Deck

WNB Below Cellar Deck
Infield and export flowline risers
Platform hazardous open drains tank
Platform closed drain vessel
Platform non-hazardous open drains tank
Fresh air inlets and combustion air inlets for: <ul style="list-style-type: none"> • HVAC systems for the Temporary Refuge, High Voltage switch room, workshops and laboratory • Firewater pumps; and • Emergency generator.

WNB accommodation modules

The permanent accommodation module is located on the Main Deck in the southwest corner, and has lower, intermediate and upper levels.

Lower level

The lower level comprises the following key rooms:

- Field Superintendent’s office;
- First aid room;

- Electrical distribution room; and
- Galley and mess area
- Laundry
- Change room
- Hot Water Heaters
- Gymnasium
- One 4-person cabin

Intermediate and upper level

The intermediate level is comprised of the following:

- Five 2-person cabins;
- Three 4 person cabins;
- Field Superintendent's cabin;
- Coordination centre;
- TV Lounge and Recreation Room.

The upper level has 16 two-person cabins.

All levels

The following rooms are on each level:

- Janitor room;
- Air handling room – the fresh air inlet is located on the south face at each level;
- Internal stairway linking all levels;
- Corridor; and
- External walkway and stairway.

WNB helideck

The helideck is located directly on top of the accommodation module. Access to the helideck is via two stairways. The helideck includes bunding and an overboard drain pipe.

2.4.3 Unutilised Assets

2.4.3.1 Wandoo-1

The Wandoo-1 subsea well is located within Permit Area WA-14L. The Wandoo-1 subsea exploration well is located within 50m of Wandoo A structure and the Wandoo B – Wandoo A gaslift line (see Figure 2-3). It was drilled in May 1991 to a total depth of 1570m MDRT. Two hydrocarbon bearing zones were discovered, the M.australis oil bearing sandstone reservoir and a deeper second non-developed gas source located within the Aalenian sediments. Both

formations were isolated by cement within and behind the 9-5/8" casing string. Both formations have been abandoned with permanent abandonment barriers compliant with abandonment requirements when drilled and would be compliant with current (modern) abandonment standards.

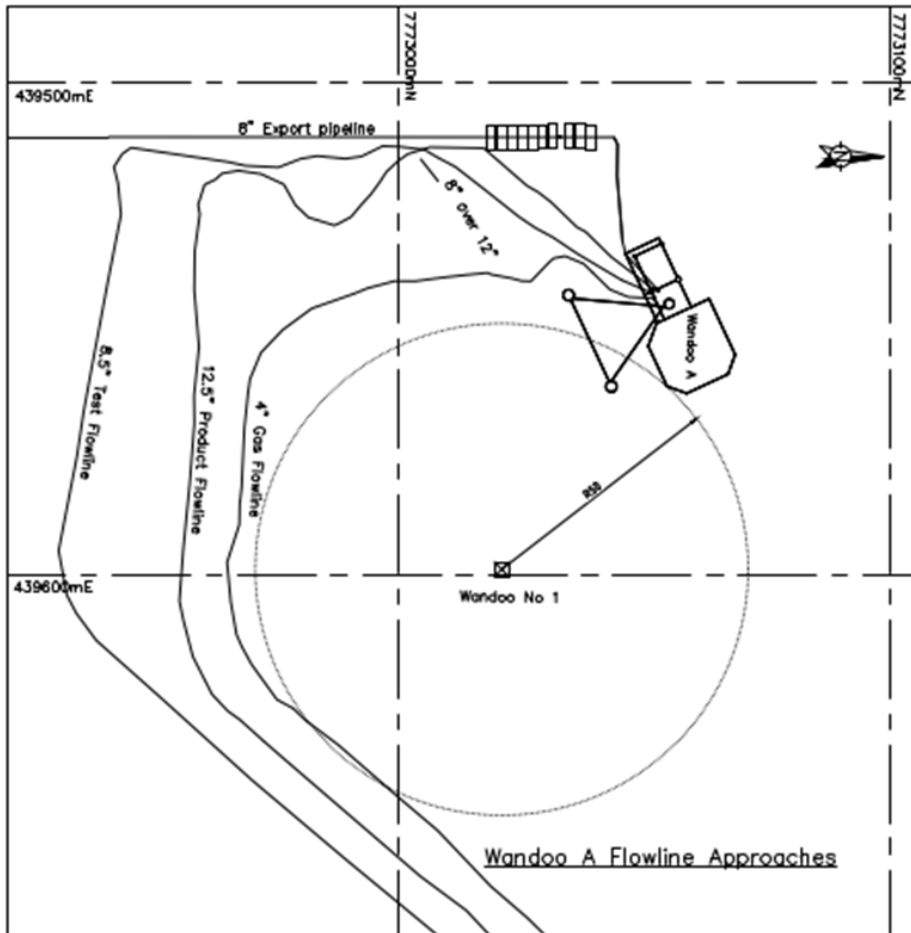

Figure 2-3 Wandoo-1 Location (WNB-5000-DG-0004.11)

Wandoo-1 was suspended in June 1991 at reservoir level with permanent abandonment barriers (cement plugs) compliant with abandonment requirements when drilled and would be compliant with current (modern) abandonment standards. Components of the well above the abandonment barriers (cement plugs number 5 and number 6) are no longer deemed exposed to hydrocarbon formations or forming part of the barrier envelope, as outlined in the VOGA Wandoo-1 Well Operations Management Plan (VOG-1000-YG-007). The Wandoo-1 well has no surface equipment installed to conduct integrity tests of the shallow and/or surface suspension or the casing. Hence the only well integrity activity available is visual inspection of the wellhead condition at seabed. As the casing strings above the top abandonment barrier (cement plug number 6) are not part of the well barrier envelope, any casing corrosion that results in communication between the casing strings will not impact the Wandoo-1 subsea well integrity. Figure 2-4 is a well barrier schematic for Wandoo-1 showing locations of the cement plugs.

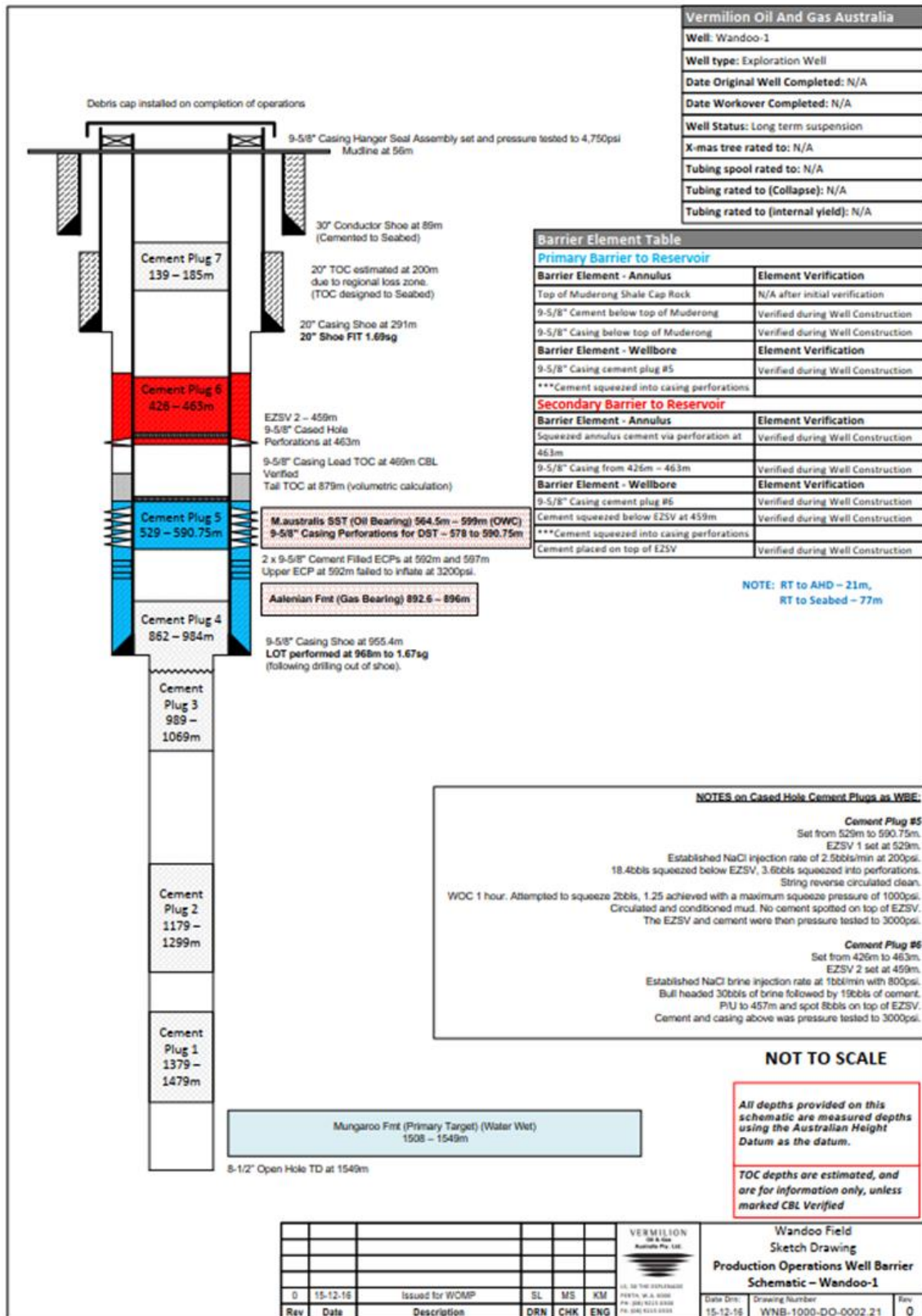

Figure 2-4 Wandoo-1 Well Barrier Schematic

It should be noted that:

- Wandoo-1 is unlikely to create additional impact to the environment or stakeholder activities then currently considered for Wandoo A and B infrastructure. It has a relatively small foot print and is located within the petroleum safety zone.
- Wandoo-1 was abandoned at reservoir level and the well infrastructure ends at the seabed in accordance with the standards at the time it was drilled. As the shallow and surface abandonment barriers have not been verified in accordance with current VOGA well construction standards the well is not considered as abandoned and is being managed as a long-term suspended well.
- Due to the current state of Wandoo-1, and the sub-hydrostatic pressure within the Wandoo reservoir, the inherent hydrostatic of the sea water column and column of fluids within the well ensure that a permanent overbalance is in place at reservoir level at all times. As such, any loss of control event will unlikely result in a release from the reservoir.

VOGA plan to continue to manage the well under VOGA Wandoo-1 Well Operations Management Plan (VOG-1000-YG-007), until such a time that it is deemed feasible (from cost and technical risk perspective) to complete abandonment of the well and remove wellhead from seafloor. VOGA anticipate the Wandoo-1 complete abandonment to be carried out when the Wandoo A wells are permanently abandoned; following cessation of production from the Wandoo field.

2.5 Hydrocarbon production

2.5.1 Reservoir fluids

2.5.1.1 General

The properties of the reservoir are displayed below.

Table 2-9: Reservoir properties

Reservoir	
Depth	563m – 650m below Mean Sea Level (MSL)
Current Reservoir Pressure (at 600m MSL at 1 Jan 2020)	~5,100kPa (0.89SG) (740psi)
End of field life pressure (at 600m MSL)	4,702kPa (682psi)
Temperature (at 600m True Vertical Depth [TVD] Subsea)	50°C

2.5.1.2 Crude oil and gas composition

Table 2-10 shows the compositions of the reservoir fluids.

Table 2-10: Compositions of reservoir fluids

Component	Mol %	Weight %
Hydrogen Sulphide	0.00	0.00
Carbon Dioxide	0.24	0.04
Nitrogen	0.06	0.01

Component	Mol %	Weight %
Methane	21.46	1.43
Ethane	0.01	0.00
Propane	0.00	0.00
Iso-Butane	0.00	0.00
N-Butane	0.00	0.00
Iso-Pentane	0.00	0.00
N-Pentane	0.00	0.00
Hexanes	0.00	0.00
Heptanes Plus	78.23	98.52
Total	100.00	100.00

2.5.1.3 Properties of Heptanes Plus

Table 2-11 shows the properties of the process fluids.

Table 2-11: Properties of Heptanes Plus

Property	Separator liquid	Separator gas	Well stream
API gravity at 60°F	19.5	-	-
Density - gm/cc at 60°F	0.936	0.737*	0.936
Molecular weight	303	103*	303

* The density and molecular weight of the separator gas are assumed values.

2.5.2 Facility production rates

Table 2-12 shows the Facility's design production rates.

Table 2-12: Nominal design rates

Fluid	Nominal design rate
Gas	1,200,000Sm ³ /day
Oil	6,359m ³ /day
PWTS	36,000m ³ /day

2.5.2.1 Production well profile

Wells are drilled from either WNA or WNB platforms and are completed horizontally through the reservoir, with the horizontal section extending 500m to 5,000m.

2.5.2.2 Flowing wellhead temperature

Temperatures at Xmas tree during normal operation:

- Minimum: 40°C
- Maximum: 51°C

2.5.2.3 Solution gas-oil ratio

Solution gas-oil ratio: 17.6Sm³/m³ oil (99scf/bbl oil)

2.5.3 Wandoo well types

As the Wandoo reservoir pressure is sub-hydrostatic, artificial lift is required to produce wells in the Wandoo Field. Artificial lift is currently provided by either using gas lift with excess gas injected into the reservoir through WNB-10 source/injection well, or Electric Submersible Pump (ESP). In general wells in the Wandoo Field produce liquids which are approximately 95-99% water and 1-5% oil. Wells in the Wandoo Field will only produce 100% oil immediately following a drilling campaign. Over a period of between 1 to 9 months following a drilling campaign the percentage of oil within the well fluids will reduce to the range of ~1-10%.

Consequently, Wandoo wells broadly fall into the following categories:

Gas injection well. Currently WNB-10 well is used as a gas source well and to inject excess produced gas into the reservoir gas cap. WNB-10 well can flow naturally to surface. B10 is used as the worst-case production well release event.

Wells that cannot sustain flow to surface. Most wells at the Wandoo facilities fall into this category. These wells do not contain sufficient free gas to sustain flow to surface, so when the application of artificial lift stops; either when gaslift gas into the well downhole via the gas lift mandrel stops or the ESP is stopped, (as would be the case in response to a loss of well integrity, or uncontrolled hydrocarbon release) the wells will not flow. In fact, due to the sub-hydrostatic nature of the reservoir the most likely scenario would be an influx of reservoir fluid into the wellbore where the established fluid column within the well would be balanced with the reservoir pressure with no hydrocarbon released to the environment.

Wells that can sustain flow to surface. There may be some newly drilled wells in the Wandoo Field that have sufficient free gas such that they can sustain flow to surface. These are the only well types in Wandoo Field where a production related uncontrolled release of hydrocarbon is credible. The hydrocarbon released during an uncontrolled release will depend on the stage of the well's life-cycle. That is, immediately following a drilling campaign on a well, with enough free gas to sustain flow to surface, that well could flow with 100% of liquids being oil; however, this would reduce to less than 10% oil over the subsequent one to nine months of the well being in operation. Typically, Wandoo has 2-3 new wells drilled every two to three years. Future new wells have been modelled for release rate and do not exceed the release rates of B10.

For wells that have not been drilled in the preceding nine months, and if the well could flow to surface without artificial lift, a production blowout would result in flow to surface with only 5-10% of that liquid flow rate being oil with the remaining being water. There are currently no wells on WNA or WNB that can sustain flow (except for the gas injection well B10).

2.5.4 Flow lines and riser systems (platform and subsea)

Three 2km long subsea flow lines connect WNA and WNB. The system comprises the following "rough bore" flexible lines:

- Production line 12" nominal bore (318mm inner diameter [ID]);

- Test line 8" nominal bore (216mm ID); and
- Gas lift line 4" nominal bore (102mm ID).

Each flow line is connected to an existing carbon steel riser on WNA, and a carbon steel riser on WNB. There are Riser Shutdown Valves (RSDV) on both WNA and WNB for each flow line. Table 2-13 shows the properties of the various flow lines.

Table 2-13: Flow line pressure, temperature, flow rates and components

Flow line	Operating pressure (kPag)	Operating temp (°C)	Flow rates	Components
WNA – WNB Production Flow Line	1,100 – 1,700	25 – 45	Less than 200 m ³ /d oil, 3000-4000 m ³ /d produced formation water, less than 100,000 sm ³ /d formation gas plus 250,000 sm ³ /d gaslift gas	Corrosion inhibited produced well fluids & lift gas
WNA-WNB Test Line	Not used for hydrocarbon service	N/A	N/A	N/A
WNB – WNA Gas Lift Flow Line	5,800 – 6,900	40	250,000 Sm ³ / day	Methane (>95%), N ₂ , CO ₂ , H ₂ O
Export flowline	1320	35-40	150,000-300,000 bpd	Heptanes Plus (crude oil)

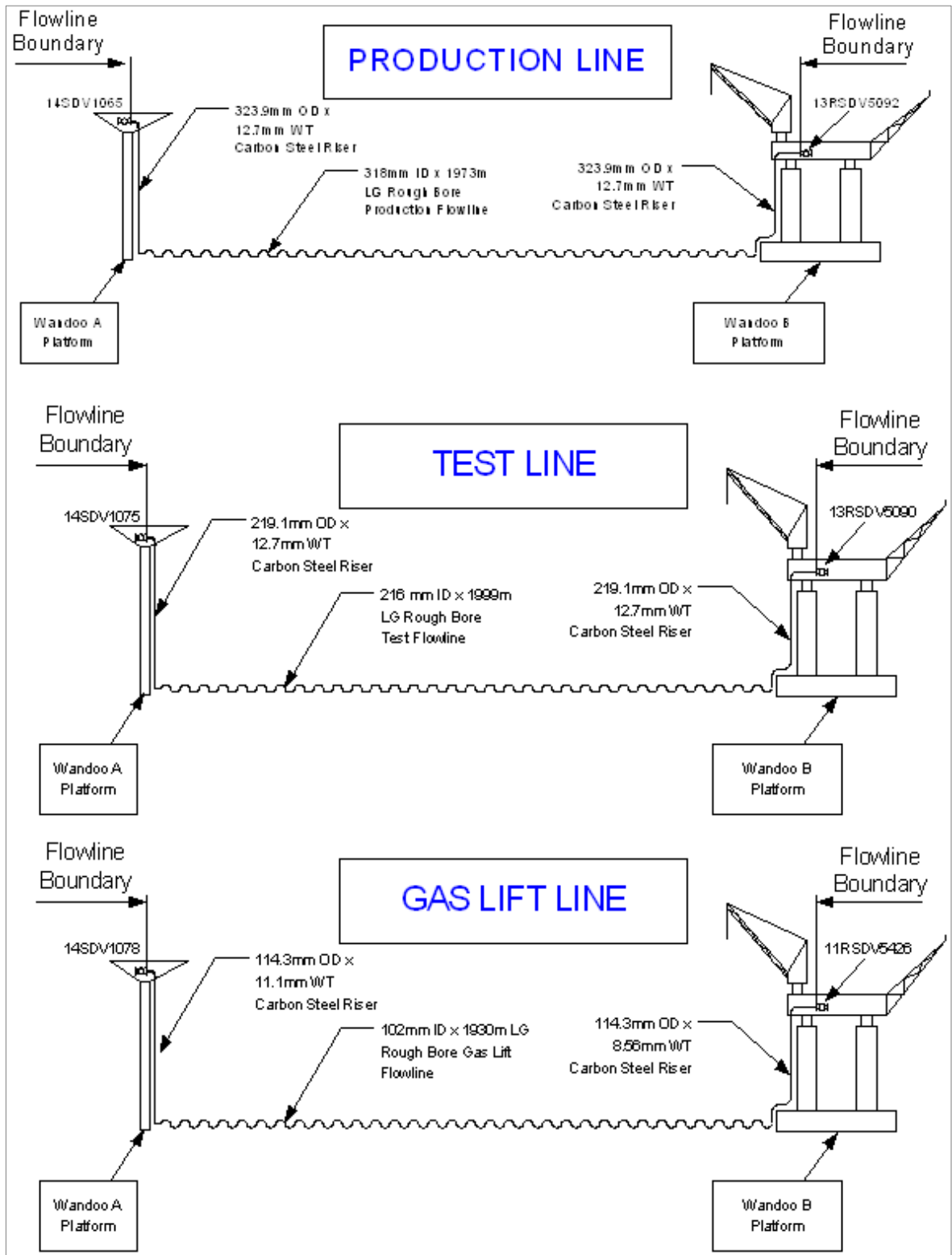

Figure 2-5: Production, test and gas lift lines

2.5.5 Wells and subsurface systems (wellheads and xmas trees)

2.5.5.1 Wellheads

WNA

Each of the WNA wells is produced through a 3000# API wellhead and Xmas tree assembly into a DN150 ANSI Class 600 flow line and into a common DN300 production manifold.

The wellheads installed on WNA are of the conventional spooled type. Wandoo A6H1/H3 is installed through the central column to the WNA monopod and wells A3, A5ST1, A8ST1 and A9 are installed through the external conductors. The wells have a 13-5/8", 3,000psi x 13-3/8" slip-on bradenhead with a 13-3/8" x 30" landing base which was landed on the 20" surface casing when the 13-3/8" casing was run. The bradenhead is welded to the 13-3/8" casing stub on the inside and outside. A mudline suspension system is used to support the weight of the 13-3/8" casing string.

After running the 9-5/8" casing (which is hung off inside the 13-5/8", 3,000psi x 13-3/8" bradenhead), the tubing spool, which has two 2-1/16" flanged side outlets are installed. Each side outlet is equipped with a manual gate valve. One side is used to monitor annulus pressure while the other is used for lift gas injection. The 5-1/2" completion is hung off the tubing hanger which is landed out inside the tubing spool. The tubing hanger and tubing spool have penetrations for the Subsurface Safety Valve (SSSV) control line and, on wells (A6H1/H3) converted as multilateral producers, a continuous penetration for the tubing retrievable flow control (TRFC) valve control line. The tubing hanger has a profile to accept a backpressure valve or tree test plug which can be installed by wireline or manually. In 2015 the A5ST1 installation was completed there is no difference in design above the production packer.

In 2010, well A6 was converted into a multilateral producer. There is no difference in the design of the A6 well above the production packer except for the additional control line for the TRFC.

WNB

Each of the remaining original WNB wells (B1, B2, B3, B4ST1, B6, B7, B8/ST1, B9ST1, B10) is produced through a 3000# API wellhead and Xmas tree assembly into a DN150 ANSI Class 600 flow line and into common DN300 production and DN200 test manifolds.

The WNB 13H and 14H wells, installed in 2008, are produced through 5000# API wellhead and Xmas tree assemblies and have DN200 production flow lines rated to ANSI Class 600. The WNB B15ST1 and B16ST2 wells drilled in 2018/19 are produced through 3000# API wellhead and Xmas tree assemblies and have DN200 production flow lines rated to ANSI Class 600.

Each WNB well includes a hydraulically operated subsurface shutdown valve, pneumatically operated surface shutdown master valve (except for the WNB 13H and 14H wells – which have hydraulically actuated Master Valves), gas lift shutdown valves and three manually operated switching valves which enable alignment of any well to the production or test manifolds. For the WNA wells the setup is the same.

The tubing hangers on all wells have continuous penetrations to enable the SSSV control line and, in some cases, the TRFC control line to be fed through. This line then exits through penetrations in

the tubing spool. WNB 10 is fitted with a PDHG. The gauge cable is terminated in an explosion-proof wellhead outlet.

For the wells that have been converted as multilateral producers (B5/ST1, B8/ST1, B11/ST1, B12ST2/ST3), the second penetration has been used as a penetration point for the TRFC control line and, if the tubing spool had no second penetration, the tubing spool was replaced with a 5-penetration unit. The tubing hanger has an internal profile designed to accept a Back-Pressure Valve or tree test plug which can be installed by wireline or manually.

The tubing spool has two 2-1/16" outlets with a flanged manual gate valve on each. The pressure is read off on one side. On the production wells, the other side is used to inject the lift gas into the 5-1/2" x tubing 9-5/8" casing annulus. The wellhead also has a 2-1/16" manual gate valve on the outlet on the tubing spool section to allow the pressure to be monitored in the 9-5/8" x 13-3/8" casing annulus.

All tree and wellhead connections are API flanged except for the wellhead sections on B15 and B16 which are a proprietary (OEC) Cameron D-shaped flange.

In 2010 and 2012, wells B5, B8 and B12 were converted to multilateral producers. There is no difference in the design of these wells above the production packer except for the additional control line for the TRFC.

WNA

A 3000psi single block tree has been installed on each wellhead. The tree body has manual lower master, gas master and manual swab valves. The pneumatic actuator for the upper master valve is tied into the platform Emergency Shutdown (ESD) control system. A manually operated 5-1/8" production wing valve is flanged to one side while a 2-1/16" manual kill wing valve is bolted on the opposite side.

All tree and wellhead connections are API flanged.

WNB

The Xmas trees on WNB 1, 2, 3, 4ST1, 6, 7, 8ST1, 9ST1, and 10 are single block 3,000psi rated and have a manual lower master valve, a wireline cutting actuated upper master valve, a manual swab valve, an actuated production wing valve and a manual kill wing valve. The pneumatic actuators are tied into the platform shutdown logic sequence.

The WNB 13H and 14H Xmas trees are also single block, but are rated to 5,000psi and fitted with hydraulic actuated master and flow wing valves.

The WNB 5/ST1, 11/ST1, 12ST2/ST3, B15ST1 and B16ST2 utilise a tubing spool with a side through bore. A horizontal block tree comprising a manual 5-1/8" 3000 psi gate valve, an actuated 5-1/8" 3000 psi gate valve and a manual 2-1/16" 5000 psi gate valve is flanged to the tubing spool side outlet.

All tree connections are API flanged.

2.5.5.2 Wells and subsea systems (down-hole equipment)

All wells have 5-1/2" or 7", 13 Cr L80, premium connection tubing installed. Sand production into the wellbore is mitigated by down-hole sand control across the production intervals in the form of prepacked or premium wire wrapped screens.

The primary safety device in each well preventing the uncontrolled flow of well fluids, should an event occur that precludes the use of surface safety systems, is a SSSV. The SSSV has metal-to-metal seals. It is a 'fail-safe closed' valve, with the valve being normally held open by surface applied hydraulic pressure via a 1/4" control line. The SSSV is generally set at approximately 110m Measured Depth Subsea (water depth is 54m Indian Spring Low Water), while B5/ST1, B11/ST1, and B12ST2/ST3, B15ST1, and B16ST2 have their SSSVs set at around 290m, 500m and 450m, 690m and 670m Measured Depth Subsea respectively (water depth is 54m Indian Spring Low Water).

Each well has a production packer installed at approximately 550m TVD Rotary Table (RT). This packer, in conjunction with a tubing seal assembly, provides the main annulus/reservoir isolation.

The completion design allows the setting of wireline plugs in nipples or blank tubing for isolation, temporary gauge installation, etc.

Each producer (except for B11/ST1, B12ST2/ST3, B15ST1 and B16ST2 which are lifted via an ESP) has one side pocket mandrel fitted for gas lift (B12ST2/ST3, B15ST1 and B16ST2 do not have a gas lift mandrel). Lift gas is injected down the tubing by 9-5/8" casing annulus and through gas lift valve (GLV) set in the side pocket mandrel into the tubing to lift production fluids from the well. The GLV is a 'fail-safe closed' orifice valve which is held open by the gas lift pressure and closed automatically when gas lift pressure is removed.

B11ST1, and B12ST2/ST3, B15ST1 and B16ST2 are lifted via an ESP. the ESP is deployed on 4-1/2" tubing string inside a 7" x 7-5/8" x 5-1/2" completion with the ESP sitting either inside the 7-5/8" section or the 7" section.

The TRFCs installed on wells A6H1/H3, and B8/ST1 are down-hole hydraulic sliding sleeves that are installed below the production packer in each of the wells to control flow from the main and lateral production intervals. The TRFC does not have a safety function and is not part of any ESD or safety function loops.

2.5.6 WNA process description

2.5.6.1 Overview

WNA is operated remotely from WNB. Reservoir fluids are produced through five gas lifted wells (WNA 3, 5ST1, 6H1/H3, 8ST1 and 9). There are no processing facilities on WNA, and all well production fluids are sent to WNB platform via the production flowline. A second flow line is used to supply lift gas from WNB to WNA.

Each well flow line is equipped with a low pressure (LP) pilot on the segment of the flow line upstream of the remotely operated choke, an electrical resistance probe, temperature and pressure measuring devices.

The lift gas is imported from WNB via a lift gas line. The lift gas is not dried at WNB therefore condensation will occur in the subsea flow line. Condensed liquid in the lift gas flow line is removed in the Gas Lift Knockout Drum (14-V-101) and the liquid is returned to WNB with the production fluids.

No instrument air is available on WNA; therefore, lift gas is regulated to 700kPa and used as instrument gas. Instrument gas passes through the Instrument Gas Scrubber (14-V-100) before it is distributed to the various users. Instrument gas exhausts from the users is manifolded to the monopod vent for safe disposal. WNA process design is that should any significant deviation from normal occur, the well system or complete facility is shutdown. On WNA surface or subsurface shutdown, flow lines are not blown down. RSDVs close on both WNA and WNB, retaining operating pressures and fluids in the flowlines and risers.

Refer to Figure 2-6 for the process flow diagram of the Wandoo facilities.

2.5.6.2 WNA isolatable hydrocarbon inventories

The isolatable hydrocarbon inventories on WNA are summarised in Table 2-14, based on the design process conditions. Actual inventories at typical operating conditions will in most cases be less.

Table 2-14: Isolatable hydrocarbon inventories

Inventory	Pressure (Bara)	Temperature (°C)	Total vapour (m ³)	Total liquid (kg)
1 - Production Flow Lines	12.0	50	1.0	145
2 - Production Header	12.0	50	2.2	319
3 - Gas Lift System	61	21	2.7	0
4 - Production Flowline	10.9	36	177.2	0.8
5 - Test Flowline	10.9	36	81	0.4
6 - Gas Lift Flowline	69.4	40	22.6	0

Note that the test riser and flowline systems are currently isolated and preserved and no longer used for hydrocarbon service. It is used for round trip flushing with treated water of the production riser and flowline system.

2.5.6.3 WNA gas lift system

Gas imported from WNB via a DN100 subsea flow line is used for gas lift of the production wells. A riser shutdown valve (activated by LP pilot or by any surface shutdown) isolates WNA topside from the gas lift import flow line. A gas lift receiver (14-R-100) facilitates pigging of the DN100 gas lift flow line from WNB. Liquid condensing in the lift gas flow line system is separated in the WNA Gas Lift Knockout Drum (14-V-101). Liquid from the knockout drum is routed to the production header. The separated gas goes to the DN100 manifold from which it is distributed to provide gas lift to five producing wells and supply to the instrument gas system. Each gas lift line is equipped with shutdown valve, flow meter and flow controller, LP pilot and gas lift Emergency Shutdown Valve (ESDV) mounted on the wellhead annulus wing valve.

2.5.6.4 Instrument gas

An instrument gas system (with bottled nitrogen back up) replaces a typical instrument air system due to the lack of compressed air source on WNA. The instrument gas passes through Instrument Gas Scrubber (14-V-100) for liquid removal before reaching the distribution header. No liquid separation is expected during normal operation. High liquid level switches provide alarms at WNB for abnormal operation resulting in liquid build-up. In the event of pressure control valve (14-PCV-1061) failure, high pressure in the scrubber 14-V-100 is detected by 14-PSH-1210 causing closure of scrubber inlet shutdown valve 14-SDV-1131. The platform will continue to operate on nitrogen backup gas until the problem is resolved or bottled nitrogen is depleted giving time for operators to transfer to WNA solve the problem or to shutdown WNA in a controlled manner.

2.5.7 WNB process description

2.5.7.1 Overview

WNB platform provides facilities for processing, storage and export of Wandoo crude. It has 15 production well slots and one gas injection well.

Using gas lift or electric submerged pumps (ESPs) for artificial lift, crude oil is produced from each well via individual wellheads, through the well headers and horizontal choke valves to Production (two off) and Test manifolds. There the produced fluids combine with the production fluids from WNA.

The crude processing facility consists of primary oil/water/gas separation followed by heating and then secondary three-phase separation and solids removal. Wells which produce high volumes of solids can be directed to a dedicated primary oil/water/gas separator, that includes an online solids removal system, before being sent to the secondary three-phase separator. The crude is cooled and stored in the concrete gravity base structure. Crude is pumped from storage via a metering package, subsea flowlines and a CALM Buoy to a tanker during export operations.

Separated gas from the primary and secondary separation is compressed to provide lift gas for the WNA and WNB wells, and fuel gas to the WNB gas lift compressor and main power generators. Produced gas in excess of requirements is reinjected for both environmental and fuel conservation management strategies into the reservoir via the gas injection well provided for this purpose.

Refer to Figure 2-6 for a process flow diagram of the Wandoo facilities.

2.5.7.2 Process inventories

The Wandoo well fluids consist of a range between 93% and 99% water cut mixture of high boiling point crude and PFW, along with associated methane gas. The main topsides inventory of the well fluids is contained within the Test Separator, three Production Separators and the Second Stage Separator. The crude is stored in the CGS compartments.

Table 2-15 shows the properties of various vessels.

Table 2-15: Vessel pressure, temperature and flowrate

Vessel	Liquid Flowrate (m ³ /day)	Pressure (kPag)		Temperature (°C)		Max slug size (m ³)
		Design	Operating	Design	Operating	
Test separator	2,385	1,100	750	80	49	3.2
Production separator (2)	19,080	1250	700	60	40 – 50	16.0
Production separator No 3	14,340	1050	700	120	40 – 50	16.0
Second stage separator	19,078	400	400	120	60	N/A

The main gas inventory is contained in the test, 3 x production and Second Stage Separators, together with the lift gas and recovered gas compressor packages and the fuel gas treatment system.

Chemical storage and injection facilities are provided on WNA and WNB and are operated and stored from bunded areas. Highly flammable chemicals are avoided if practical alternatives exist.

2.5.7.3 WNB isolatable hydrocarbon inventories

The isolatable hydrocarbon inventories on WNB are summarised based on the design process conditions. Actual inventories at typical operating conditions will in most cases be less.

Table 2-16: Isolatable hydrocarbon inventories

Inventory	Pressure (Bara)	Temp (°C)	Total vapour (m ³)	Total liquid (kg)
1 (Production flowlines, manifolds and headers)	8	40	7.5	2,300
2 (Test separator)	7	40	31.0	1,213
3 (Production separator x 2)	7	40	86.4	1,485
4 (Production Separator No.3)	7	40	53.22	1,400
5 (Second stage separator)	5.6	85	105.2	73,320
6 (Crude heat exchangers)	5.6	70	1.6	1,316
7 (Gas compression header)	8.9	39	3.1	0
8 (Gas compressor)	22.7	40	10.9	0
9 (Gas lift manifold)	70.1	40	0.4	0
10 (Fuel gas scrubber)	18.8	5	3.4	0
11 (Fuel gas header)	4.4	25	14.6	0
12 (Recovered gas)	6.8	40	2.7	0
13 (Oil metering)	15.8	40	0	2,632

2.5.7.4 Separation and conditioning

Two production separators (PS1 & PS2), operating in parallel provide free water ‘knockout’ and gas separation. A third production separator (PS3) has been added which includes online solids removal. The crude emulsion carryover from the production separators is heated in plate heat

exchangers before being routed to the Second Stage Separator for further separation of crude, water and gas.

The crude from the Second Stage Separator is cooled in plate heat exchangers prior to being routed to one of the storage compartments located in the CGS.

Two pumps, one dedicated to each storage compartment, operate in parallel to provide oil export flow. The pumped oil is metered on topsides and exported via subsea flowlines to an export tanker at the CALM Buoy.

A common three-phase test separator is provided for WNB well testing. The test separator is sized for 15,000bpd liquids, the nominal design well flow rate. Downstream of the test metering equipment, the crude stream is fed to the Second Stage Separator and the water stream to the Produced Water Treatment System. Gas from the test separator is routed to the gas lift compressor.

Low-pressure gas from the Second Stage Separator is compressed in the Recovered Gas Compressor then re-routed to the Lift Gas Compressor suction. The recovery of low-pressure gas minimises the flaring of hydrocarbon gas from the facility.

Second Stage Separator Bypass

In 2021 the Second Stage Separator requires a total platform shutdown and maintenance programs are currently in place to shut down this vessel for an extended duration, approximately 20 days. Following the introduction of ESP wells at Wandoo B, it is possible to continue production and bypass the Second Stage Separator vessel while the maintenance is undertaken. Under this arrangement all gas lifted wells will be shut down and isolated along with the gas lift compressor.

As part of the review of the shutdown campaign, a change is being considered for review under Vermilion's management of change process (Section 7.8). The change will be assessed in Q2 2021 and scope will involve:

- bypass of the second stage separator;
- operation of the 1st Stage Separators, PS1 and PS2, will be operated to provide the same functionality and instrument protection as the Second Stage Separator process conditions and PS3 will be shutdown;
- All WNA and WNB gas lifted wells will be shut down and isolated along with the gas lift compressor; and
- WNB process being operated as follows:
 - Crude Oil stabilization will occur in the PS1/2 separators prior to transfer to the rundown coolers. This process condition is similar to the existing 2SS operating condition;
 - Associated gas will be directed to the LP flare system and/ or the pilot/purge gas system. A total flowrate of approximately 8,000 Sm³/d will be produced and suitable for flare header purging/pilot system;
 - Separated produced water will be treated via the hydrocyclones and the ISFUs. Vendor data has indicated that the above PW flowrates can be treated in the hydrocyclones at the reduced operating pressure and still provide a separation efficiency of over 80%. The

combined Hydrocyclone and ISFU PW treatment train will treat the Overboard PW to well within the threshold limits (Table 2-19);

- The produced oil from the separators will be combined with the stabilised Closed Drains fluids and the Recovered oil from the hydrocyclones/ISFU's and then routed via the Oil Rundown Coolers to the CGS storage cells; and
- PS1 and PS2 vessels have the same instrumented protection/shutdown functionality as the 2SS. These systems are fully integrated to ensure protection of the CGS and to meet the PFW OIW overboard limits.

Although there is a minor increase in CO₂ emissions as a result of flaring the associated gas (approx 13 t/d) there will be an overall net reduction in GHG emissions because the GLC is not in operation and burning any fuel during the shutdown saving approx. 90 t/d.

If the Second Stage Separator bypass arrangement is proven successful in 2021, it will be utilised as an option for future major maintenance/inspection campaigns for that vessel.

2.5.7.5 Solids removal

On-line solids removal is achieved with the use of Solids Recovery Cyclone (SRC) manifolds, installed in the base of the new PS3 and second Stage Separator. Motive fluid in the form of produced water is used to fluidize the solids, for removal from the vessel. The motive fluid is sourced from the outlet of the Induced Static Flotation Unit No. 2 (ISFU2) recirculation pumps. The solids are directed to a solids removal system consisting of appropriately rated tanks, to collect and store the slurry before disposal onshore.

2.5.7.6 Gas Lift

The lift gas compressor is a two-stage centrifugal compressor. Each stage has independent surge control. An overall compressor recycle line and control valve is installed. The valve position is set depending on compressor control and throughput requirements.

Lift gas flow to each well is measured and flow controlled. Surplus gas is routed to the gas injection well for injection back into the reservoir.

2.5.7.7 PFW treatment

Water produced from the wells is treated and processed through the production process and is discharged as PFW. Up to 32,000m³ of PFW is currently discharged per day at the facility. The PFW is discharged 8m below the water surface at a temperature of ~51°C. The PFW flow rate is managed to a maximum flow rate of 32,000m³/day, with a daily average oil in water (OIW) acceptable limit of 12.5mg/L (refer to Table 2-17 for acceptable and unacceptable PFW OIWs at proposed flow rate regimes).

Two hydrocyclones are installed on the main production separator water outlets for PS1 and PS2 on the WNB Main Deck. A third hydrocyclone is installed on the cellar deck for treatment of the water from PS3. The hydrocyclones serve primarily to separate oil droplets from the PFW streams emanating from the production separators and reduce OIW content.

The water from the hydrocyclones is routed to the ISFU1 or ISFU2. Recovered oil from the hydrocyclones is fed to the recovered oil tank or the recovered oil vessel and then pumped onto

the Second Stage Separator. PFW from the Second Stage Separator is treated in ISFU1 or ISFU2 to further reduce OIWs prior to discharge.

2.5.7.8 PFW Upgrades

Background

The Wandoo Field commenced production in November 1993 and over 50% of the estimated oil in place has been recovered to date. This is a very high recovery factor, with the ultimate recovery factor estimated at 60+% (dependent on maintaining commerciality). Most high-permeable, water flooded fields in the world would expect recoveries up to 40% as an exceptional ultimate recovery factor. The high recovery of the Wandoo Field is a direct result of the quality of the reservoir and the aquifer pressure support, which is the source of the PFW. The average produced field water cut is currently ~96% with typical production of ~1.6–2.4mmbbls in a calendar year.

Ultimate recovery assessments are conducted based on the end of the economic viability of the field, not necessarily the end of the reservoirs ability to produce oil. Adding production volume directly contributes to revenue, while the costs to operate and maintain the Wandoo Field stay generally fixed, making the asset more efficient. By improving the economic viability over a long term, the ultimate recoverable reserves will also increase. The current production capacity due to the reservoir quality and pressure support is greater than the current overboard water limitation.

The 2017/18 upgrade increased total fluid production rates, and reduced OIWs, thereby improving the economic viability. This extends the duration of time Wandoo could be economically produced, and thus increases the ultimate estimated recoverable reserves.

The proposed upgrade has the same objective and enables solids producing wells to be produced at their maximum rates (increase total fluid production rates) whilst managing a key cause of OIW performance.

2017/18 Upgrade

The Wandoo Field originally included two coalescing vessels which were historically used to remove water from oil prior to the oil accumulating in the storage cells. These vessels were in service when the field produced at significantly lower water cuts. Now that the field produces ~96% water the vessels are not required for oil polishing and the process was bypassed around these vessels. One of these vessels was modified to become ISFU 2 and added to the PWTS to help reduce the OIW. This vessel conversion mimicked the PWTS, namely the ISFU, resulting in a total of two flotation units. The previous vessel, the ISFU 1, achieved 90% of the current oil recovery from water, however that vessel was at capacity and did not process the entirety of the process water at Wandoo. The installation of the second flotation unit reduced the load on the original unit and enabled the entirety of the process stream to flow through one of the oil recovery vessels.

The completed upgrade to increase the total fluid production rates, at reduced OIWs, was achieved in 2018 by improving the process as outlined below:

- Increased well production via four downhole electric submersible pumps (ESP) met the increase in water handling capacity.

- Increased the capacity of the two hydrocyclones from 5,000 to 10,000m³/day to increase the flow rate through the production separators. This resulted in a corresponding hydrocyclone size increase from 30" to 42" outer diameter (OD).
- Converted the redundant first stage coalescer to ISFU operation. This involved modifying the vessel internal pipework and providing a "microbubble" generating pump. The ISFU2 was commissioned in Q1 2018.
- Upgraded the recovered oil system to route the separated oil back to the second stage separator.
- Upgraded the OIW monitoring system.

Due to the high efficiency of OIW recovery of the existing ISFU, the addition of the second flotation unit and other processes improvements has achieved an improved OIW concentration of 12.5mg/L or lower at a maximum PFW throughput of 32,000m³/day with a corresponding increase in base oil production rate of ~30% (795kLOPD to 1030kLOPD).

OIW performance issues

From late 2017, Wandoo B began receiving a noticeable increase in solids being produced from three wells. A review of all wells identified producing wells B12ST2/ST3, B13H and B14H resulted in solids (which can be oil coated) being carried into the separation trains. This results in reduced produced water treatment system performance as solids build up in the vessels can impact on operability system and oil/water separation.

Analysis of high OIW excursion events recorded in accordance with the Produced Water Adaptive Management Strategy [WNB-7000-RP-0010] (refer Section 6.7.6) from September 2017 to June 2020 was undertaken. This identified 12 months that each recorded over 25 events per month, with sediment ingress into the process as the direct cause of over 80% of these events (427 of 510). These 12 months of high OIW excursion event numbers accounted for approximately 80% of the daily acceptable OIW limit exceedances (71 of 91) during the period.

Proposed upgrade

Proposed upgrade to Wandoo processes involves creating a solids removal system utilising a dedicated process stream for solids producing wells, via producing the solids producing wells into Production Separator 3 (PS3) and solids removal equipment installed into the Second Stage Separator (refer to Figure 2-6). The goal of the solids removal system (PS3 conversion and installation of solids removal equipment into the Second Stage Separator) is to limit OIW impact and reduce production impact when solids are being removed from process vessels. The outcome of introducing the solids removal system, will enable ISFU 1 and 2 to work at full capacity (process 18,000m³/day), resulting in total produced water discharge capacity of 36,000m³/day.

2.5.7.9 Ballast water storage, treatment and discharge

Sea Water is used to ballast the Facility during hydrocarbon export. As oil is exported, ballast water flows into Shaft 4 and into the compartments via the buffer cell to replace the exported oil. Ballast water discharge is generally equal to daily oil production and is typically managed between 700–1,500m³/day. Typical OIW of ballast water is a low <3mg/L due to the long residence time and dilution in the tanks and buffer cell, and the deep suction location of the ballast water pumps.

Ballast water is pumped via one of two ballast water pumps in a duty/standby arrangement. The electric submersible pumps are located in caissons within Shaft 4.

Water level in Shaft 4 is controlled via the ballast water pump flowrate by an automated level control valve. This maintains the drawdown level to an elevation of approximately 15m below sea level. The water is discharged to sea via the ballast water OIW analyser on the topsides then discharged overboard with the PFW discharge. Ballast water is monitored for OIW content and only water within specification is discharged overboard.

Hypochlorite is injected continuously into the facility seawater service system intakes.

2.5.7.10 Combined PFW and ballast water discharge

The historical average volume of PFW and ballast waste discharged per day and the OIW concentration is outlined in Table 2-18.

Table 2-18: Annual PFW and ballast water OIW and flow rate averages

Year	Ballast Water Flow Rate	PFW Flow Rate	Ballast Water OIW	PFW OIW
	m ³ /day	m ³ /day	mg/L	mg/L
2007	1,193	17,100	9.8	22.0
2008	1,076	22,386	16.4	21.4
2009	1,241	23,320	8.0	15.6
2010	1,169	21,513	2.0	13.2
2011	1,298	23,165	2.3	11.0
2012	1,011	21,532	1.8	12.4
2013	1,030	21,550	1.9	11.3
2014	1,044	21,022	3.1	14.7
2015	1,026	22,355	4.3	13.6
2016	1,037	21,941	2.2	11.7
2017	957	22,612	2.5	13.8
2018	764	24,101	2.0	8.0
2019	970	24,729	1.0	8.3

Table 2-19 outlines the total volume production flow rate and associated target acceptable 24-hour OIW limits. The PFW throughput was increased in stages until a flow rate maximum of 32,000m³/day was achieved in 2018 with an acceptable 24-hour PFW OIW performance of 12.5mg/L or less. A maximum flow rate of 37,500 m³ (36,000 m³/d PFW and 1,500 m³/d Ballast water) and OIW of 11.1mg/L is proposed.

The ongoing flow rate regime used will depend on the flow rate that can be delivered from the wells and the OIW performance possible from the treatment system. The OIW targets are based on mass balance calculations where the total quantity of oil in the PFW is not increased as

throughput is added. Continuous efforts to improve OIW management are made and typical performance is maintained under this acceptable limit.

The unacceptable 24-hour limits (see Table 2-20) if exceeded, would be considered a recordable incident.

Table 2-19: PFW and ballast water flow rates and acceptable OIW limit

Flow Rate Regime	Ballast Water Flow Rate	Maximum PFW Flow Rate	Acceptable OIW 24-hour Limit
m ³ /day	m ³ /day	m ³ /day	mg/L
26,100	1,500	24,600	16.7
28,500	1,500	27,000	15.2
30,500	1,500	29,000	14.2
33,500	1,500	32,000	12.5
37,500	1,500	36,000	11.1

Table 2-20 Unacceptable OIW 24-hour limits

Flow Rate Regime	Unacceptable OIW 24-hour Limits
m ³ /day	mg/L
26,100	30.0
28,500	25.9
30,500	24.2
33,500	22.0
37,500	19.5

2.5.7.11 Ballast water oil interface system

A temporary skimmer pump can be used in Shaft 4 when necessary to remove any possible oil carryover floating on the ballast water surface.

2.5.7.12 Oil storage system

The two large oil storage compartments in the CGS base are filled with oil floating on top of seawater (ballast water), and maintained at a drawdown pressure by keeping the water level in Shaft 4 at an elevation of ~15m with respect to LAT.

Stabilised and degassed, Crude at atmospheric pressure and ~40°C flows into the 'rundown' caissons and into the storage compartments or cells displacing its own volume of ballast water. The top interconnections between the cell groups of each of the larger storage compartments allow oil to flow between them and maintain a uniform level. The displaced ballast water flows into the buffer cell and then into Shaft 4. To ensure that the ballast water outflow equals the crude production, the ballast pump discharge flow is adjusted to maintain the Shaft 4 water level set point. The ballast water is discharged to sea via the ballast water OIW analyser on the topsides.

Chemical treatment (biocide) of oil storage compartments may be infrequently required to minimise microbial growth and is typically done during exports via biocide treated produced water added at Wandoo A.

When export of the oil is required, the oil is exported to the tanker moored at the remote CALM Buoy. Normal practice is to export from both compartments simultaneously along with concurrent oil production. One oil export pump is provided for each storage compartment. The pump impellers are vertical type shaft driven and are located in glass reinforced epoxy caissons and are top driven by electric motors situated on the Cellar Deck. The pump can be withdrawn for maintenance when necessary.

2.5.7.13 Oil interface system

The Interface Layer system is designed to remove any oil/water emulsion that may form at the interface in the oil storage compartments. The inlet suction is situated below the level of oil export suction inlet in the storage compartments. The interface pump is run during export and the system detects the change in density of the interface before it rises to the oil export pump inlet level. This ensures the export crude does not include any free water.

Each main oil storage cell compartment has its own interface pump. The buffer cell also has an interface pump to recover any oil that may be carried over should the main storage cells be accidentally overfilled. Fluid recovered by the interface system is diverted back to the oil storage compartments.

2.5.7.14 Seawater for cooling

Seawater is primarily used for processing and utilities cooling at WNB but also provides firewater ring main pressurisation and is a feed source for the potable water maker and the hypochlorite generator. Approximately 1,000m³ seawater is pumped into the facility per hour. Seawater is

lifted from the sea by one or two of three seawater lift pumps, more seawater is required for cooling in summer than winter due to the increase in ambient seawater temperature.

To prevent marine growth in the seawater system, seawater is treated by continuous dosing of hypochlorite at 1-2mg/L which is consumed by organic material prior to discharge. The heated seawater is discharged directly to the ocean after usage. Seawater discharged to the ocean (at surface) from the cooling system is elevated in temperature by 2-3°C.

Freshwater generated by the on-board reverse osmosis plant (Section 2.6.9) is also used to top up the closed loop facility cooling medium system which provides process and machinery cooling. The cooling water contains a corrosion inhibitor at a dosage rate of around 0-5% of total cooling system volume, which equates to approximately 20L per year.

2.5.7.15 Sand filtration

The Wandoo reservoir is unconsolidated sandstone that is prone, if not controlled, to excessive production of sand, where the sand comes to the surface with the produced oil and water. Historically, any solids, including sand and rock fragments accumulate in the production vessels and they are removed during plant shut downs, and are then transported to shore for treatment and disposal. In the future, these solids will be able to be removed from PS3 and the second stage separator whilst these vessels are online via the solids removal system. Recovered solids will then be transported to shore for treatment and disposal.

The quantity of sand produced at Wandoo has historically been minimised by the installation of down-hole sand control across the production intervals in the form of prepacked or premium wire wrapped screens. However, three wells currently produce more solids than the other wells (B12ST2/ST3, B13H and B14H) and will be treated via the solids removal system described in Section 2.5.7.8.

2.5.7.16 Chemical injection

Production chemicals are injected at various stages in the process for following purposes:

- Prevention of marine growth and scale formation within utility pipework;
- Management of internal corrosion of pipework; and
- Optimising process separation of oil and water.

The following chemicals are added into the PFW streams:

- Corrosion inhibitor;
- Water clarifier;
- Oxygen scavenger;
- Scale inhibitor;
- Reverse demulsifier;
- Forward demulsifier; and
- Biocide is also added in batches as part of flow line and riser pigging operations with details outlined in Section 2.7.3.

2.5.8 Flaring, blowdown and process venting

2.5.8.1 Flare and blowdown

Production gas is separated from the well stream by the production separators. Production gas is divided into fuel gas, lift gas and reinjected gas. Fuel gas is used to power the generators and compressor. The excess amount of the remaining gas is reinjected. If the compressors are unable to cope with large volumes of gas coming into the separators the excess gas will be diverted to flare to maintain pressure control. Flaring is only used for separator pressure control and safety reasons and is a key component of the ESD and blowdown systems.

The flare system consists of:

- Pressure control valves on each major process vessel or system;
- Relief devices at source;
- Relief headers routed to the inlet of the flare knockout drum. The knockout drum is sized for knocking out liquids above 300 microns size during gas blowdown;
- Flare outlet pipe, supported on a flare boom from the knockout drum to the flare tip; and
- Flare tip with flare ignition pilots.

The flare knockout drum is sized to remove significant liquid droplets from the gas stream at maximum throughput.

Pressure relief devices and blowdown valves protecting equipment and piping systems are routed to the flare system. Maintenance venting of pressurised hydrocarbon systems and pressure control of the separators are also routed to the flare system.

The automatic blowdown of the process pressure vessels and lines is initiated by fire or confirmed gas detection on the platform. The blowdown system is sized to depressurise the process vessels quickly and safely as per performance standard requirements

The relief and blowdown discharge is routed via header lines to the Flare Knockout Vessel, sized to remove entrained liquid from the gas. The separated gas is routed to the flare tip via flare header. The separated liquids are returned to process via the closed drains system.

The blowdown system is tested as per performance standard requirements.

The flare system is designed to handle the maximum throughput from the blowdown systems. The flare system is rated for 60,000Sm³/hr. The blowdown rate is calculated as 27,000Sm³/hr. Flare volumes or rates are monitored, and the platform aims to minimise flaring as far as possible. Generally, the WNB flare is low enough that it is only visible at night. There is monitoring and detection of both pilot burners' functionality including an alarm if the pilot goes out.

The gas is primarily comprised of methane (CH₄) and inert nitrogen gas (N₂) used to purge and sweep some of the hydrocarbon containing equipment. The primary by-products produced from flaring are carbon dioxide (CO₂), carbon particles, and water. Trace amounts of hydrocarbons, carbon monoxide (CO), oxides of nitrogen (NO_x) and oxides of sulphide (SO_x) are also present. Fuel gas that is combusted in the turbines produces similar by-products.

2.5.8.2 *Process vents*

Smaller volumes of other gases are vented from some of the oil rundown caissons, the produced water treatment system, diesel storage tanks, and from the electro-chlorinator which emits low levels of hydrogen gas (H₂). The rate of venting is based on the daily process throughput.

Cold venting from the flare is rare and generally avoided. Cold venting from flare should only occur if the flare pilots are malfunctioning and are not lit.

Nitrogen is used as a blanket inert gas within the WNB process low pressure vents and flare. This sweeps the headers and prevents high concentrations of methane (CH₄) from building up within the pipework.

Small quantities of methane are also released from WNA via pneumatic chemical pumps and instrument gas system vents.

These gases contribute to the atmospheric emissions associated with the activity and are reported as part of the NGERs reporting requirements.

2.5.9 **Process control features**

2.5.9.1 *Production*

Production flow from each WNB well can be adjusted using the manual choke valves, but in practice it is controlled primarily by the gas lift flow rate or ESP speed. The gas lift rate to each well is measured and is controlled by a flow control valve. ESP speeds are governed using a Variable Speed Drive (VSD). The optimum production rate required for each well is normally set following well testing.

To ensure that the ballast water outflow equals the crude production, the ballast pump discharge flow is adjusted to maintain the Shaft 4 water level set point. Selection of well routing from WNA and WNB wells for the test separator and either of the two production separators is achieved by manually operated header valves.

2.5.9.2 *Level control*

The WNB separator level control systems provide the ability to operate the separator interface level by either direct level control from the displacer instrument in the separator to the stream outlet valve, or by imposed cascade control where the outlet valve operates on a flow control set point cascaded from the level indication from the displacer measurement in the separator. This provides a secondary control method for the interface level, which can be difficult to measure in heavy oil separation at lower temperatures and provides a damping of liquid outflow during slug flow to the separators.

2.5.9.3 *Well fluid heating*

Process flow from First Stage to Second Stage Separation is heated by flowing through a crude heat exchanger to improve oil/water separation in the Second Stage Separator.

2.5.9.4 Crude pumps and metering

During oil export start-up, the pumps are started on re-circulation control prior to the metering system 'ramp-up' sequence of controlling the export throughput. Pump minimum flow is maintained by monitoring the metered flow rate and the recirculation flow rate to control the bypass rate.

2.5.10 Safety control systems for use during emergencies

2.5.10.1 General

The following systems are provided for control during emergencies.

- Fire and Gas (F&G) detection system;
- Process Shutdown (PSD)/ESD system;
- Matrix panel;
- ESD-0 Relay panel; and
- Monitoring and Control System (MCS).

2.5.10.2 WNA systems

Fusible plug/ESD panel IP101

The ESD panel IP101 includes:

- Subsurface and surface shutdown of WNA wells;
- The provision of a surface output from the panel to trip, instrument gas scrubber shutdown valve – gas lift flow line manifold valves and gas lift knockout drum shutdown valve;
- Repeat pressure switches to monitor the gas lift flow line pressure pilots;
- All local manual override/trip hand switches on IP101 have one common override/test/run pressure switch at the remote telemetry unit; and
- Remote reset/start-up override header.

Subsurface control panel IP-102 provides subsurface shutdowns and interface for workover control.

Valve shutdown panel IP103

The valve shutdown panel IP103 includes:

- The production flow line shutdown logic allows the shutdown of valve 14-SDV-1065 to be activated from WNB or locally on surface shutdown;
- The test flow line shutdown logic allows valve 14-SDV-1075 to be shut down from WNB; and
- Gas lift isolation valve 14-SDV-1078 can be reset from WNB or locally.

Note that the test riser, header and flow line systems are currently isolated and preserved and no longer used for hydrocarbon service. It is used for round trip flushing of the production riser and flowline system.

Interface control panel IP104

The interface control panel contains the following:

- A gas reset header/manifold with electrical solenoid and quick release valve to allow start up override operation from WNB;
- Solenoids for individual well surface shutdown initiated from WNB;
- Repeat switches 14-PSL-0100 to 0500 for monitoring upper master valve open/closed status;
- Manual override/test/run hand switches for the gas lift wing and manifold shutdown valves;
- Gas lift manifold pressure pilot and repeat switch;
- Instrument gas scrubber high-pressure pilot and repeat pressure switch to monitor the pilot status; and
- Repeat pressure switch to monitor the gas scrubber high level alarm.

Simultaneous Operations (SIMOPS) with MODU

During well construction operations, an ESD-1 (subsurface shutdown) electrical link is installed on the MODU, with shutdown buttons placed in the Doghouse and the Radio Room. The ESD loop is linked up to the ESD panel IP101. Prior to commencement of the well construction operation, the ESD loop is function tested to ensure that the correct signal is being sent and received.

2.5.10.3 WNB systems

Fire and gas detection systems

The F&G detection system initiates all ESD executive actions including ESD-0 (e.g. control system and battery isolations), ESD-1, ESD-2, platform alarms, firewater and appropriate fire suppressant systems. The fire protection systems on WNB include:

- Water deluge to process areas;
- CO2 suppressant systems to turbine and emergency generator enclosures; and
- Foam (Aqualoy) systems to fire pump enclosures and galley range hood, water sprinkler system to accommodation internal rooms.

It also sends a signal to the PSD/ESD system to initiate other ESD levels. The hardware consists of a dedicated 'Triconex' programmable logic controller connected to the 'Honeywell' MCS. All F&G status and alarm conditions are displayed on the control room console Visual Display Unit (VDU) graphics. Operator actions acknowledge (e.g. alarm logic reset, fire zone lockouts, setting maintenance overrides) are initiated from the graphic displays or keyboard action.

The 'Triconex' systems have triplicate internal architectures and the MCS interface hardware is duplicated to increase the availability and safety of the systems. Power to the 'Triconex' systems is supplied from two independent 24V DC battery-backed power supplies.

Process and emergency shutdown system

The PSD/ESD system initiates all ESD 1, 2, 3 and unit shutdown actions. The hardware consists of a dedicated 'Triconex' programmable logic controller connected to the MCS for display of all shutdown alarms on the VDU graphics and facilities for operator actions (e.g. unit shutdown resets, setting maintenance overrides).

Matrix panel

The process matrix panel consists of switches, pushbuttons and indicators and is wired directly to the PSD/ESD system. The F&G matrix panel is wired directly to the F&G system to provide direct operator execution of emergency outputs and actions.

ESD-0 – Relay panel

The ESD-0 relay panel is an independent hardwired system designed to initiate ESD-0 executive actions in the event of a total failure of the F&G system. Without the F&G system, the safety of the platform cannot be monitored, necessitating a total shutdown of the facilities. Initiation of ESD-0 is from pushbuttons in the control room and at the lifeboat stations; and is initiated automatically when all three F&G processors fail or if gas is detected within the Temporary Refuge (TR) area.

Monitoring and control system

The MCS is in the Central Control Room (CCR) within the TR and performs all monitoring and control functions on WNB and provides operations and monitoring interfaces to the F&G, PSD/ESD and WNA systems. The MCS consists of Honeywell Experion hardware that has a duplicated architecture to increase system availability. The control room console contains five VDU-based four operator stations and multiple displays and three printers that are used for reporting, indication and alarming of the MCS, PSD/ESD, F&G and WNA systems. All displays and operator functions are accessible from operator stations.

Monitoring is also possible remotely through Honeywell Experion station and LAN connection. The Experion provides easier Honeywell maintenance and engineering upgrades to be completed on the monitoring system and is an additional screen which displays critical alarms. Excessive number of alarms can be silenced during an emergency to give the operators a better focus on the key control actions.

SIMOPS with MODU on WNB

During well construction operations, an ESD-1 (subsurface shutdown) electrical link is installed on the MODU, with shutdown buttons places in the Doghouse and the Radio Room. The ESD loop is linked up to the ESD panel IP101. Prior to commencement of the well construction operation, the ESD loop is function tested to ensure that the correct signal is being sent and received.

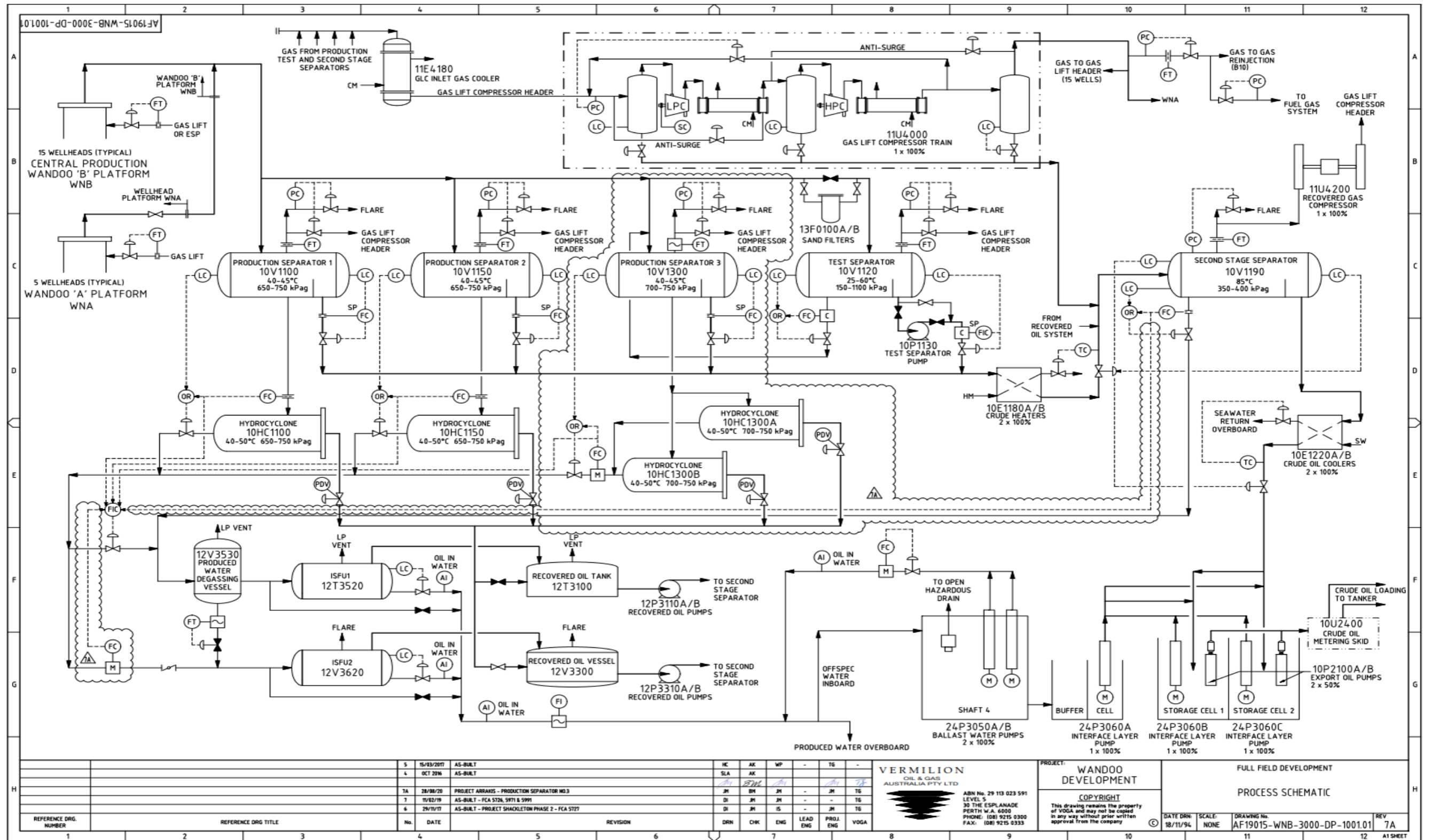

Figure 2-6 Process flow diagram of Wandoo facilities

2.5.11 Export of hydrocarbons

2.5.11.1 Export system flow lines

The export lines inventory is crude oil of the required specification. Table 2-21 shows the properties of the export system.

Table 2-21: Export system line pressure, temperature, flow rates and components

Flow line	Size	Operating pressure (kPag)		Design temp. (°C)	Flow rates	Components
		Design	Operating			
Export Flowline	2No 14" NB	2700	1320	60	150,000 - 300,000bpd	Heptanes Plus (crude oil)
PLEM	14" OD (manifold and piping)	1960	-	21 to 40	150,000 - 300,000bpd	Heptanes Plus (crude oil)
Submarine Hose Assembly (SHA)	10 X 16" NB	-	1900	-20 to +82	150,000 - 300,000bpd	Heptanes Plus (crude oil)
Floating Hose Assembly (FHA)	1 x 12/16" NB 23 x 16" NB	-	1900	-20 to +85	150,000 - 300,000bpd	Heptanes Plus (crude oil)

2.5.11.2 CALM Buoy system

The tanker anchoring zone is located five nautical miles from the Wandoo facilities. The Wandoo Mooring Master boards the vessel two nautical miles out from the terminal. A series of safety checks are then undertaken before piloting and berthing the tanker onto the CALM Buoy that is located 1.2km north of the WNB platform. A three-knot speed limit applies within the 500m restricted zone. The CALM Buoy is 15m in diameter and 8m deep and comprises a central chamber surrounded by six watertight compartments. Two of these compartments are filled with polyurethane foam to ensure positive buoyancy should accidental flooding occur.

The buoy is anchored to the seabed by six anchor lines.

The central chamber contains the product pipework that connects the under-buoy hose to the Product Distribution Unit (PDU). The PDU comprises a fixed inner section and an outer section that is free to rotate with a rotating arm assembly and permits the tanker to weather vane about the buoy whilst continuously loading crude oil.

The rotating arm assembly comprises a pipe arm, mooring arm and balance arm. The pipe arm carries the crude flow to the floating hose. The mooring arm provides an attachment point for the mooring hawser. The balance arm is oriented to counterbalance the weight of the mooring arm and pipe arm, thus balances the mooring loads and allowing the arms to rotate.

Pre-start and routine checks are performed of the vessel during offloading in accordance with requirements of the SPM Marine Facilities Procedures (WPA-7000-YV-0002). Whilst the shipping service checks the tanker for class and compliance with terminal requirements, the mooring master signs off on the vessel prior to allowing the ship to proceed to berth at the CALM Buoy. The tankers remain on site for up to 48 hours.

2.5.11.3 Offtake operation

Overview

Oil is offloaded from the WNB CGS through twin 348mm 1.2km long flexible flowlines to a CALM Buoy via a Pipelines End Manifold (PLEM) and submarine hose system.

The oil export pumps draw the oil from the storage compartments of the CGS through the oil export product storage facility lines in Shaft 4. The oil then passes through the metering skid located at the north end of the Cellar Deck and Shutdown Valves (SDVs). The oil then travels down twin 355.6mm outer diameter (OD) carbon steel risers located on the external west face of Shaft 1 to a twin 1.2km flexible flowline system from WNB to a CALM Buoy via a PLEM and submarine hose system.

The system comprises the following:

- WNB topside export piping from each storage cell with an individual export pump, metering run and ESDV installed on the Cellar Deck. The systems are flanged to a tie-in to the platform export risers;
- A flowline riser (356mm OD) installed externally down the west face of Shaft 1 of the CGS, crossing to the south of Shaft 4 to the western edge of the platform substructure to terminate approximately 1m above the scour protection, 20m from the northwest corner of the substructure; and
- Two 348mm ID approximately 1,250m long smooth bore flexible flowlines running due north from the platform. Flowlines are flanged to the riser and to the PLEM. Subsea flowlines are subject to regular subsea inspection where the support of the flowline on the seabed is inspected for scouring or change.

A gravity based subsea PLEM structure contains the 356mm OD manifold pipework. Flow is commingled via equal diameter barred 'Tee' and is configured to allow for future 'round up' pigging of the subsea lines. The pipework contains a single diver operated, in-line ball valve downstream of the manifold. Pipework terminates in a single 400mm NB ANSI class 300 bolted flange.

Tanker movements

The offtake tankers have a maximum capacity of 700,000bbl, with exports from Wandoo ranging from 80,000bbl to a maximum loading of 350,000bbl. Tankers usually arrive empty, although in some instances they can be co-loaded at another facility before arriving at Wandoo.

Tanker movements occur every three to eight weeks, depending on production rates and market requirements. Duration of export activity is typically 12-24 hours depending on the export cargo size and transfer rate.

The most frequently used tanker type is the Suezmax, details are outlined in Table 2-22. The largest fuel cell capacity is in the order of 5,000m³, due to the variation in tanker designs VOGA has used 10,000m³ as the largest worst-case credible spill volume.

Table 2-22: Tanker details

Name	Length (m)	Cargo tank capacity (m ³)	Heavy fuel oil capacity (m ³)	Diesel capacity (m ³)
Suezmax	281.20	185,447	4,025	130

Inerting and venting of cargo tanks

Inerting of tankers cargo tanks is predominantly using inert gas that is extracted from exhaust emissions of the tankers engines heavy fuel oil (HFO) and is required to prevent potential tanker explosions, through build-up of an explosive gaseous oxygen/hydrocarbon mixture above the liquid phase. The mooring master checks with the tanker Master that this has been done prior to loading. During loading, this inert gas is vented through the vessel sealed vent stack as the tanks fill with crude displacing the inert gases.

2.6 Support activities for operations

Includes all supporting activities required to meet the primary activities of processing, storage and export of hydrocarbons from the Wandoo Facility.

2.6.1 Crane operations

Platform cranes transfer materials to and from the supply boats and any materials on the WNA and WNB platforms. Table 2-23 shows crane types and locations on the Wandoo platforms.

The cranes on WNA and WNB are powered by diesel engines.

Table 2-23: Crane types and locations on Wandoo platforms

Platform	Model	S/N	Boom length	Winch capacities				Engine
				Main hoist		Fly hoist		
				Low	High	Low	High	
WNA	60 RL	824	12	7	N/A	N/A	N/A	Isuzu 6BD1
WNB	ML 6400	26651	39.6	25	10	N/A	N/A	GM8V-92TA

2.6.2 Marine vessel operations

Support vessels are normally contracted to support the Wandoo Facility operations, and provide the following services:

- Supply materials and services and bulk and liquid waste removal;
- Diesel bunkering;
- Offtake operations;
- Vessel based marine mooring facilities maintenance;
- Diving operations for inspection, maintenance and repair of subsea infrastructure;
- Surveys including remotely-operated vehicle (ROV), side scan sonar, sub-bottom profiling;
- Emergency response, including standby and rescue and on-site oil spill response.

Examples of typical support vessels used for these activities is provided in Table 2-24.

Table 2-24: Example support vessel details

Activity	Vessel name	Gross Tonnage
Production support, diesel bunkering and ROV	Bhagwan Athos	2237
	Mermaid Guardian	499
Air diving	Mermaid Investigator	1271
Dive support/construction vessel (saturation diving)	Sapura Constructor	8337
	Subsea 7 Eagle	9556

It is estimated that infield vessel movements at the Wandoo Facility are in the order of one per week. Saturation diving vessels only as required for specific activities but generally are a one in five-year event. Most of these vessels are based in Dampier.

All vessels are required under contract to comply with all State and Commonwealth legislation for the control of all sources of pollution and of discharges at sea, Marine Orders (enact MARPOL) and quarantine requirements. In addition, all vessels are required to have a Shipboard Oil Pollution Emergency Plan (SOPEP).

2.6.3 Helicopter operations

Primary personnel access to the WNA and WNB platforms is by helicopter. Normal transport of materials is by supply vessel. Helicopter transport is used on occasion for small items requiring urgent delivery.

It is estimated that helicopter movements at the Wandoo Facility are in the order of four per week, with one trip per week to the WNA Facility.

2.6.4 Diesel bunkering

Diesel bunkering is undertaken in accordance with the procedure outlined in the Platform Operations Manual. Diesel fuel required for fuelling the Facility is transferred from a supply vessel via a flexible hose to the WNB platform. The diesel bunkering hose connects to receiving manifold on the WNB topsides which provides coarse filtering of the diesel before directing flow to Shaft 2 inlet standpipe. Shaft 2 has a maximum diesel storage volume of 2,500m³. Bunkered diesel is treated with diesel fuel preservative or equivalent (aquatic biocide) to ensure fuel is suitable for long-term storage in Shaft 2. This will remain in the diesel and is not discharged. On completion of the diesel transfer from the support vessels, the contents of the hose are drained back to the vessel tanks(s). An end cap is fitted to the flexible hose before it is recovered from the vessel deck and stored on the facility hose saddles.

The frequency of diesel bunkering depends on the diesel storage capacity of the supply vessel used and supply vessel availability. The largest bunkering vessel that is used has three tanks each with a storage capacity of 400m³. Bunkering takes place as required depending on operational needs. The average supply vessel has a diesel storage capacity of 200m³.

2.6.5 Waste management

The VOGA Waste Management Procedure specifies that all wastes, apart from approved discharges are stored in suitable containers on the platform and returned to shore for disposal.

The waste streams covered by this procedure fall into three main categories:

- Recyclable (non-hazardous).
- General (non-hazardous).
- Hazardous.

The procedure provides detailed information and guidance to ensure that waste is correctly identified, classified, labelled, stored, transported, treated, and disposed of in accordance with regulatory and VOGA requirements.

2.6.6 Chemical Management

Procedures specified in the applicable Safety Data Sheets (SDS) are followed whenever handling chemicals. The SDS are managed in a database (HSE MS Element 11 – Information Management Documentation and Records). Both offshore and onshore personnel can consult the database. A Job Safety Analysis (JSA) is conducted for any work that involves the handling of hazardous substances, as outlined in the Wandoo Work Management Manual [WPA-7000-YG-0021].

The Wandoo Work Management Manual also outlines the following:

- Action required in the event of chemical contact;
- Labelling of decanted substances; and
- Personal Protective Equipment (PPE) required for chemical handling.

Areas where chemicals are used and stored are prepared by:

- Providing appropriate protective equipment;
- Training of affected personnel;
- Ensuring appropriate safety and spill response equipment is readily available;
- Erecting warning signs;
- Providing access to SDS; and
- Providing required bunding.

Chemicals classified as dangerous goods must be stored in accordance with the requirements of the dangerous goods class.

2.6.7 Power generation and compression

The facility main Alternating Current (AC) power is provided by two Gas Turbine Driven Generator Sets (located on the Main Deck), and one Diesel Driven Emergency/Standby Generator set located on the Cellar Deck. The two Turbine Driven Generator Sets have the capability of running on a diesel or natural gas fuel supply.

The Turbine Driven Generator Sets are the normal source of AC power for the Facility. The two Turbine Driven Generator Sets and the Standby/Emergency Generator Set have the capability of parallel operation. The requirement for initiation of parallel operation is dependent on Facility load demand and to suit operational procedures, such as carrying out routine maintenance/load checks on the Standby/Emergency Generator.

The AC power for the Facility is generated at 6,600V AC and distributed at 415V, three-phase, four wire facilitating provision of neutral earth resistor for current limiting of neutral to earth fault via two 6,600/415V step down transformers. Each of these transformers can provide the total power requirements for the Facility LV loads. In normal operating conditions, both transformers are operative and share the AC electrical load of the Facility.

The voltage levels utilised on the Facility are listed in Table 2-25 below.

Table 2-25: Voltage levels at the Facility

Equipment	Voltage levels
Main Turbine Driven Generators	6,600V AC, 3P (three-phase), 50Hz, four wire, 4MW
Emergency Diesel Generator	415V, 3P, 50Hz, four wire, 240V AC, two wire
High Voltage (HV) Motors	600V AC, Note: that all electric motors on the facility are started direct online except for the four down-well ESPs.
LV Motors	415V AC, 3P, 50Hz (the fractionally rated motors, are 240V AC)
Lighting	240V AC, 50Hz
Switchgear Controls	24V DC
Motor Controls, start/stop/local/ remote	24V DC
Fire and Gas, Master Control Panel	24V DC and 240V AC, 50Hz
Navigational Aids	12V DC nominal with 14V DC feed and 240V AC
Emergency Lighting	240V AC, each of the emergency fluorescent light fittings is provided with an integral battery pack
Link Radio/Public Address (PA) System	-48V DC
Ultra-High Frequency (UHF)/Very High Frequency (VHF) Radio	+12V DC and 240V AC 50Hz
Entertainment/Data Systems	240V AC 50Hz

2.6.8 Laboratory

A laboratory is located on the south end of the Mezzanine Deck on WNB and is used to analyse routine process samples.

Laboratory wastes are generated during testing well stream, ballast water and PFW characteristics. The wastes comprise n-pentane, acetone, hydrochloric acid and the detergent "Quantum Clean". Oil soluble chemicals are disposed to the CGS oil storage.

All hazardous waste generated in the laboratory are disposed of in accordance with the Waste Management Procedure.

Laboratory sinks and drains are connected to the open drains tank for separation and recovery.

2.6.9 Potable water production

The desalination plant produces approximately 60m³ of potable water per day.

The volume of reject water produced is dependent on the amount of potable water required on the platform but is estimated to be approximately 500m³ per day. The salinity of the discharged reject water is slightly higher than seawater and contains small quantities of scale inhibitor. The reject water is discharged directly overboard.

2.6.10 HVAC and refrigeration systems

The ventilation, pressurisation and air conditioning systems on the WNB platform are divided into discrete areas according to the specific requirements of the area.

The separate areas with dedicated Air Handling Units (AHUs) are as follows:

- HV & LV Switch Rooms, Battery Rooms, Temporary Refuge (Muster Area, Equipment Room, Control Room and Communications Room)
- Mech Workshop, InElec Workshop, Store Room and Laboratory
- PLQ Lower Level
- PLQ Intermediate Level
- PLQ Upper Level
- PLQ Extension (XLQ)
- The Shaft 4 air space is force ventilated with fresh air via fans and ducting but does not contain any heating or refrigeration equipment

Chilled water to first five AHUs above is supplied from the original central chiller package located on the south west corner of the Mezzanine level. There are two sea water cooled chiller units and operating in a duty/standby configuration.

Chilled Water to the XLQ AHU is supplied from the XLQ chiller package located on the south centre of the Main Deck. There are two air cooled chiller units operating in a duty/standby configuration.

Additional Heat Pump type refrigeration units are installed for:

- 2 x Galley Cool Rooms located on the Main Deck south at the PLQ Lower level for food storage
- External Freezer Room on Main Deck south for food storage
- HV Switch Room booster coolers on Mezz Deck south east. 3 x units were added to manage increased the thermal loads from ESP VSDs installed in the HV Switchroom
- Crain operators cabin air conditioning

The HVAC dampers are fitted where required for fire & gas isolations and are tested as per Critical Function Test (CFT) requirements.

Maintenance and servicing of HVAC and refrigeration systems is generally performed by a specialist third-party service provider.

2.7 Maintenance, inspection and project activities (on Facility)

2.7.1 Rigless well intervention works

Most rigless well interventions at Wandoo are remedial operations performed on production wells with the intention of restoring or increasing production. A well may require intervention due to flow restrictions, replacement of ESP equipment, changes in reservoir characteristics, sand production, mechanical failure, or to access additional hydrocarbon pay zones.

Rigless well intervention techniques may include Light Well Interventions (LWI) or Heavy Well Interventions (HWI). Light Well Interventions would typically include operations utilising

- Electric (wire) line (EL);
- Slick line (SL); and
- Pumping

Heavy Well Interventions would typically include operations utilising:

- Coiled tubing (CT); and
- Hydraulic workover (HWO)

Rigless well intervention activities do not require the use of a MODU, and the equipment packages have the capability of performing down hole applications in live (under pressure) wells. However, typically well intervention operations at Wandoo are carried out following the depressuring of the wells. Although wells may be “depressurised” and effectively won’t flow to surface, intervention is still under pressure and requires the use of tested Pressure Control equipment.

SL is the most common rigless intervention activity carried out at Wandoo. The SL is run on a hydraulic powered winch system and is fed into the well through a set of pressure control equipment (stuffing box, lubricator and BOP). It involves the use of a thin (2.7mm or 3.2mm diameter) high strength chrome steel wire to convey tools into and out of the well. The SL cannot supply electricity to down-hole tools, although some tools are powered using independent power packs. It is primarily used for “through tubing operations” to conduct fishing, gauge cutting, setting or removing plugs, deploying or removing retrievable valves and memory logging operations and the maintenance/change-out of GLVs.

EL is a steel armoured mono or hepta core electric cable that can transmit well data continuously to the surface or conveying signals to down-hole tools. The EL is run on a hydraulic powered winch system and, during intervention operations, is typically fed into the well through a set of pressure control equipment (stuffing box, lubricator and BOP). It is primarily used for “through tubing operations”, taking production logs and setting/pulling plugs; it is also capable of conducting perforation operations. If EL activities need to be carried out below the production packer, the line must be conveyed into the well using electric powered down-hole tractors to pull the wire down-hole.

A CT operation involves inserting a continuous and a flexible steel pipe into a well bore. The tubing is transferred off a hydraulic powered winch system and fed into the well by an injector head (a powered set of chains and dies) through a BOP system. The tubing is a single length of

high strength drawn steel that is flexible enough to be coiled onto a reel, with diameters that range from $\frac{3}{4}$ " to 3-1/2". It is primarily used for "through tubing operations", taking production logs, pumping of fluids for stimulation or treatment purposes, setting/pulling plugs and conducting perforation operations.

An HWO operation involves the use of a hydraulic powered unit (often referred to as a Snubbing Unit). The unit uses hydraulic cylinders which carry gripper jaws that travel over a ~3m stroke, to push and pull jointed sections of pipe into or out of a well. As with all other intervention activities, HWO operations are carried out through BOP system to provide well control capability. An intervention of this type may be used if the configuration of the well needs to be changed and requires the recovery/reinstallation of the completion string. An HWO operation will also, typically, require the use of pumping, SL and/or EL as part of the activity. HWO operations are also used to run or retrieve ESP equipment into the ESP operated wells (B11/ST1, B12ST2/ST3, B15ST1 and B16ST2).

The type of operation to be undertaken determines which type of equipment package is selected.

The most common use of pumping operations on Wandoo is to kill and suspend an active well as part of a workover operation, or in preparation for a well construction campaign. It involves connecting an independent pumping unit (typically a diesel powered triplex unit) to the tree and wellhead system of the well via high pressure lines, and pumping kill weight fluid down the annulus and tubing of the well to push any hydrocarbons in the well back down below the production packer, leaving the well filled with kill weight fluid from the wellhead to the production packer. This type of equipment package may also be used for the pumping of fluids for stimulation or treatment purposes.

During well intervention works, biocide treated water is utilised in wells, risers and BOP to protect the reservoir. Following well intervention works, the well may be flowed via the process facilities to be cleaned up and the treated water is directed to either storage (CGS) or the PWTP.

Rigless well intervention works are conducted as required, historically once every one to two years.

2.7.2 Purging of gas from vessels and tanks

Tanks and vessels at the Facility need to be flushed and purged to remove hydrocarbon liquids and gas prior to activities such as confined space entry. The tanks and vessels are purged using an inert substance (e.g. Nitrogen or inhibited water) to displace the gas. The gas is purged to the flare or venting depending on the pressure.

2.7.3 Pigging with biocide

At Wandoo pigging runs are used to clean the flowlines of bio-mass accumulation to reduce microbiologically influenced corrosion (MIC). Routine operational pigging of the production line from WNA to WNB commenced in early 2006 to reduce possible MIC. The pigs are inserted into the flowlines from a pig launcher on WNA and are used to remove obstructions and biofilm on internal pipe surfaces whilst the biocides are utilised to enhance biofilm removal by the pigs and to prevent further biofilm activity in the pipework and process fluids.

The biocide used is Tetrakis (Hydroxymethyl) Phosponium Sulphate (THPS). This biocide biodegrades rapidly, as it reacts readily with any organics, and has a very short half-life in the presence of seawater. The degraded by-products are non-toxic, and there is no bioaccumulation of this product.

Currently the biocide treatment is conducted during tanker loading as this procedure enables all PFW to be diverted inboard to the storage cells, where it mixes with ballast seawater. The pigging and biocide application is completed in the first half of the procedure, to allow active biocide maximum contact time with the seawater.

Once the active biocide is exhausted, the PFW and ballast water can be discharged to the natural environment in accordance with the Wandoo Platform Operations Manual.

Testing indicates that the biocide will remain active for 2-3 hours after injection and requires a minimum of 4 hours residence time in Shaft 4 before it can be discharged overboard.

Tanker loadings presently occur at three to eight-week intervals, enabling VOGA to conduct the pigging and biocide program at these intervals.

Intelligent pigging is also undertaken on the inter-field flowlines approximately every four years to measure the wall thickness of the flowlines and to identify if corrosion above expected limits has taken place. During the process the lines are flushed with biocide (THPS) treated seawater and this is directed to storage where it mixes with ballast seawater and is both diluted and degraded before release.

2.7.4 Welding and cutting

Arc welding and oxy-acetylene welding and cutting and will be undertaken at the Facility.

Welding habitats or enclosures are used to contain sparks and welding debris. This waste is then transferred to the general waste containers on the platform and taken onshore for disposal.

2.7.5 Chemical cleaning

Chemical cleaning is undertaken on the heat exchangers and various tanks and vessels throughout the facility as required. Sulphamic acid is used for chemical cleaning, is neutralised with caustic soda following chemical cleaning and discharged neutralised to the hazardous open drain system.

2.7.6 Deck cleaning

Deck cleaning is undertaken at WNA and WNB once a week or more often if required. Drainage from the deck may contain oil, grease, detergents, dirt and other hazardous chemicals.

On WNA, deck drainage is collected through an open drain and stored in the open drain tank. The contents of the open drain tank are then transferred to a waste bulky for appropriate disposal.

On WNB, deck drainage is transferred to the hazardous and non-hazardous open drain systems. Any oily waste is separated from the collected fluid in the drains tank and systems. The oil is then transferred to the CGS and the drains water discharged overboard. Daily sampling of these overboard discharge streams is recorded in the laboratory and daily report.

2.7.7 Topside maintenance

2.7.7.1 *Blasting*

Blasting of topside infrastructure is undertaken regularly in preparation for spray painting. Methods used include:

- Abrasive blasting using sand or garnet;
- Mechanical abrasion using wire brushes; and
- High pressure water blasting.

The preferred method is high pressure water blasting. If this is not effective, mechanical abrasion using wire brushes will be used. Alternatively, if mechanical abrasion is not effective then abrasive blasting using sand or garnet is used.

Containment barriers are used to trap and collect abrasive solids; this is then transferred to general waste containers on the platform before transport onshore for disposal at approved waste disposal sites.

2.7.7.2 *Spray painting*

Spray painting is undertaken on a regular basis. Spray paint is stored in approved paint storage containers within dedicated bunds. Empty paint containers are disposed of as hazardous wastes.

2.7.7.3 *Workshop*

Mechanical and electrical workshops are located at the southern end of the WNB Mezzanine Deck. The repair, maintenance and calibration of plant and equipment are undertaken at these workshops.

2.7.8 Fire protection systems and testing

The fire protection system consists of:

- Firewater pumps;
- Deluge system;
- Sprinkler system; and
- Monitors.

There are two 100% diesel driven vertical lines shaft type firewater pumps. The pumps are located at the south of the blast wall on the east and west sides of the Cellar Deck. The pumps are tested using the full flow discharge line which dumps the water overboard.

Deluge systems provided in areas where hazards from hydrocarbon pool and jet fires exist are designed to provide 'control of burning' protection. Each deluge system comprises a deluge valve, a distribution main and distribution deluge branches fitted with spray nozzles at designated intervals.

There are deluge systems distributed across the Facility as follows:

- Cellar Deck – 5;
- Mezzanine Deck – 1;
- Main Deck – 2; and
- Over fire pumps and emergency generator enclosures.

A wet-type sprinkler system is installed in all accommodation spaces where the use of water to extinguish fires is appropriate.

There are two independent, 100%, duty water driven, manually activated, automatically oscillating type firewater monitors on the helideck. Each monitor is provided with a dedicated foam unit. The dedicated foam units have a foam storage capacity for 15 minutes supply of 1% Aqueous Film Forming Foam (AFFF). The monitors have a flow rate of 1,800m³/min and a throw of 48m as a jet and 18m as a spray.

The main deluges or hydrant systems are also used to deliver AFFF from the centralised system, which adds foam to the ring main if required. Twin outlet hydrants are provided at each fire point on the Facility.

The components of the fire-fighting system that are tested, the frequency of tests and the discharge composition are outlined in Table 2-26 below.

Table 2-26: Fire protection system testing

Component	Frequency	Discharge composition
Firewater pumps	Fortnightly	Seawater discharged directly to sea *
Deluge system	Biannually	Seawater discharged via deluge drains to sea *
Helideck	Annually	108m ³ /hr seawater. Test for five minutes, via helideck drain to sea

Note that foam testing with release to the environment during testing, training or maintenance has been suspended with alternative testing methods being utilised for helideck AFFF performance tests.

2.8 Maintenance, inspection and project activities (sea level and subsurface)

Extends to all sea level subsea activities that may be undertaken to maintain the primary activities of processing, storage and export – including integrity management.

2.8.1 Metrology

Metrology includes laser and acoustic surveys undertaken to take measurements between subsea structures (primarily interconnecting flowlines). These may include laser, sonar, tape measure, inclinometer and taut lines.

2.8.2 Side-scan sonar surveys

Side-scan sonar is a marine geophysical technique that is used to produce an 'image' of the seafloor. Side-scan sonars may be used for environmental benthic habitat mapping, inspection of subsea infrastructure and site surveys of offshore exploration permits and licences.

Side-scan transducers may be mounted on Autonomous Underwater Vehicle (AUV) systems, vessel hulls or more commonly using a towfish. The towfish is towed behind the vessel at approximately 4 knots. Towfish are generally towed at 10-20% of the swath width above the seabed.

The technique uses pulses of sound at perpendicular angles to the side-scan sonar system. Both transmit and receive sensors are contained within the same unit. When the return acoustic pulses are processed, they provide information on the amplitude of the return pulse which in turn provides information on the composition of the seabed. For example, a strong return pulse is generally associated with a harder seabed surface. Shadows on the acoustic signals can also be analysed to infer the heights of any objects on the seabed.

Side-scan sonar systems generally operate in the 100-500 kHz frequency range with a sound source level of around 220-226dB re: 1 μ Pa @ 1m (Department of Energy and Climate Change, 2011). Higher frequency side-scan sonars provide information at a higher resolution, but the swath width is generally smaller. Side-scan swath width is ultimately dependent on a combination of frequency and the height the towfish is towed above the seabed.

2.8.3 Sub-bottom profiling surveys (seismic reflection)

Sub-bottom profiling is a geophysical survey technique that is used to establish the geology of the seabed. Sub-bottom profiling techniques range considerably in terms of power and acoustic sources. Low-frequency systems can provide information to greater depths, whereas high-frequency systems give more detail at shallower depths but do not have the acoustic power to penetrate to deeper depths.

High-frequency systems such as Chirps and Pingers tend to operate in the 0.5kHz to 25kHz range. The sound source level of these high-frequency systems tends to be in the 210-220dB re: 1 μ Pa @ 1m range dependent on the specific system that is used. These systems are used for high resolution shallow surveys and are capable of penetration depths to 30m. The acoustic source and receivers are generally enclosed within a single unit. These high-frequency systems can be mounted on a vessel, AUV or mounted on a surface or deep tow towfish. Survey requirements will determine which system is used.

Lower-frequency systems such as Boomers and Sparkers tend to have a larger sound source and greater penetration of the seabed. These systems can also be mounted in surface tow or deep tow systems depending on survey water depth. Surface shallow water systems are generally used in water depths up to 100m. These systems tend to operate in the 500Hz to 4kHz range. The SEL for these systems is generally in the range of 212-226dB re: 1 μ Pa @ 1m.

2.8.4 Metocean monitoring

Metocean surveys usually involve the deployment of small-scale moorings. They are used to understand environmental conditions such as currents, wave height, tidal range and turbidity, this data is also used for engineering design for offshore developments.

Wave buoys, current profilers (AWACs, ADCPs, and Aquadopps) and metocean buoys are commonly deployed during metocean surveys. The mooring designs are dependent on water depth and equipment configuration.

The current profilers use a working frequency from 38kHz to several megahertz to measure the Doppler shift of particles within the water column.

Current profilers contain piezoelectric oscillators to transmit and receive sound signals. The traveling time of sound waves gives an estimate of the distance, the red or blue shift can be converted to a velocity. In order to measure 3D velocities, at least three vector components have to be estimated, this is why the instruments typically have four transducer heads.

For deep water deployments, acoustic releases are usually connected to the anchor/clump weights. These are released on recovery leaving the clump/anchor weight in-situ.

2.8.5 Diving and ROV

Diving operations are integral to maintenance and replacement of existing infrastructure. Replacement of FHA and Submarine Hose Assembly minor hose repairs, testing and replacement of bolts/flanges, Cathodic Protection installation and testing, stabilisation, repairs, subsea welding and cutting, cleaning and marine growth removal and installation of grout/sandbags, are examples of activities undertaken by diving contractors. Details of typical diving vessels used at the Wandoo Facility are outlined in Table 2-24.

ROVs are utilised for routine inspections of flowlines, subsea valves, flowline alignment surveys, subsea infrastructure and platform substructure inspections. Annual ROV inspections are undertaken to determine levels of seafloor scour.

ROVs are linked to an offshore support vessel by either a neutrally buoyant tether or often when working in rough conditions or in deeper water a load carrying umbilical cable is used along with a Tether Management System (TMS). The purpose of the TMS is to lengthen and shorten the tether to minimise the effect of cable drag. The umbilical cable contains a group of cables that carry electrical power, video and data signals back and forth between the operator and the TMS. Where used, the TMS then relays the signals and power for the ROV down the tether cable. Once at the ROV the electrical power is split and distributed between different components of the ROV. However, in high power applications most of the electrical power is used to drive a high-powered electrical motor which in turn drives a hydraulic pump.

The hydraulic pump is used to power equipment such as torque tools, manipulator arms and thrusters (or other means of propulsion) which help position the ROV. Most ROVs are equipped with at least a video camera and lights. Additional equipment is commonly added to expand the vehicle's capabilities. These may include sonars, multi-beam echo sounders, magnetometers, a still camera, a manipulator or cutting arm and water samplers. The class and size of the ROV used will be dependent on the survey requirements. ROVs can be launched from dynamically

positioned vessels when operating in deeper waters or from vessels that require a three to four anchor spread to secure the vessel on location when operating in shallower waters. Details of typical ROVs used at the Wandoo Facility are outlined in Table 2-27.

ROV surveys usually range from one day to several days at a single location but may extend to several weeks covering a variety of sites and offshore facilities.

Three main types of ROV will be used at Wandoo:

- Inspection class.
- Light work class.
- Work class.

The typical specifications for these ROVs are outlined in Table 2-27.

Table 2-27: ROV details

Class	Depth rating (MSW)	Size (mm)	Payload (kg)	Weight (kg)	Speed (knots)
Inspection	600	1,450 x 820 x 920	45	300	>2.5
Light work	2,000	1,515 x 1,000 x 790	80	400	>3.2
Work	1,000	3,000 x 1,450 x 1,700	150	2,500	3

2.8.6 Cleaning and marine growth removal

Subsea cleaning and marine growth removal are undertaken approximately every five years on the external surface of subsea infrastructure to prevent overloading of structures and moorings.

Marine growth that has established on the Wandoo Facility will be removed via three methods:

- Diver operated removal tools.
- Abrasive blasting.
- ROV or diver operated water blasting.

Divers will use of variety of tools (scrapers, shovels, brushes, etc.) to manually remove marine growth.

Abrasive blasting will be used at shallow depths (<10m) and will involve air entrained sand or garnet being directed under pressure at infrastructure with marine growth until marine growth is removed. At greater depths the air medium will be replaced by water and sand or garnet blasted at marine growth.

Water blasting under pressure (<10,000psi) and ultra-high pressure (>10,000psi) will be used as the third method of cleaning. Ultra-high pressure cleaning will only be carried out by ROV.

2.8.7 Subsea welding and cutting

Underwater welding is not commonly undertaken but is occasionally required for the repair or replacement of subsea assets. Underwater welding is undertaken at elevated pressure and

temperatures and is predominantly referred to as hyperbaric welding. Hyperbaric welding can either take place wet in the water itself or dry inside a specially constructed positive pressure enclosure and hence a dry environment. Dry hyperbaric welding is used in preference to wet underwater welding when high quality welds are required because of the increased control over conditions that can be exerted, such as through application of prior and post weld heat treatments. Dry hyperbaric welding involves welding at a prevailing pressure in a chamber filled with a gas mixture around the structure being welded. Wet underwater welding commonly uses a variation of shielded metal arc welding, employing a waterproof electrode.

Subsea cutting at the Wandoo Facility may be undertaken via three methods; mechanical cutting, ultra-thermic cutting and water jet cutting.

Ultra-thermic cutting uses rods at a temperature in excess of 10,000°F to cut or melt through material. The rod design feature alloy core wires retained by circular crimps.

A water jet cutter is an industrial tool capable of cutting through a variety of materials using a high-pressure jet of water.

2.8.8 Flowline stabilisation and support

Grout bags, form work and structural steel may be used for flowlines stabilisation and freespan support. The installation of grout bags involves the pumping of grout through a hose from the vessel to fill the grout bags underwater.

2.8.9 Scour protection

Scour protection may consist of grout bags, fabric formwork, fabric frond matting and crushed rock or iron ore. Scour protection has been installed around the CGS and around the subsea flow lines to prevent scouring of the seabed.

2.8.10 Subsea inspection and repair

General inspection techniques used for subsea assets include:

- General and Close video inspection, including the use of dual diode lasers for sizing;
- Ultrasonic wall thickness measurements, including Time of Flight Defraction (ToFD); and
- Crack detection inspections, including Magnetic Particle Inspection (MPI), Eddy Current Inspection (ECI) and Alternating Current Field Measurement (ACFM).
- Wet storing, removal and replacement of subsea assets

Sections of the subsea flow lines, floating hose or subsea marine hose may be identified as requiring replacement during underwater inspection and maintenance works on the Facility. Replacement involves diver disconnection of the hose or flow line section involved and installation of the new section. Disconnection and installation of the flow line section may involve welding and cutting. To ensure the potential for release of hydrocarbons from the hoses and flow lines during replacement works is minimised, the hoses will be flushed, and blinds installed prior to disconnection. This may involve the use of treated water to prevent corrosion which is directed to storage or the PWTS.

Equipment may be stored subsea on a temporary or long-term basis as part of offshore subsea projects or during situations such as a cyclone approaching.

2.8.11 Cathodic protection

CP is a technique used to control the corrosion of a metal surface. The protected metal is connected to a more easily corroded “sacrificial metal” to act as the anode. The sacrificial anode then corrodes instead of the protected metal. Sacrificial anodes have been installed in certain facility systems and components to prevent corrosion. The PLEM, CALM Buoy, flow lines and all the risers on WNA and WNB are fitted with sacrificial anodes. The anode is composed of magnesium or aluminium and has a lifetime of approximately 20 years. The anode dissolves into the sea over time.

The basic chemical reaction at the anode is:

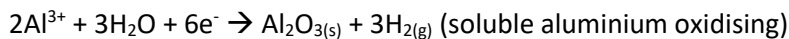
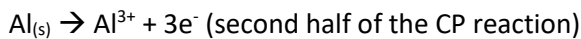

Most of the aluminium oxidises close to the anode surface, resulting in the relatively benign aluminium oxide (alumina) as well as some intermediate aluminium hydroxide compounds ($\text{Al}_n(\text{OH})_m$) covering the anode as a white scale. The intermediate hydroxides will continue to oxidize with water to end as Al_2O_3 . The oxide scale is somewhat amorphous and will wear off with time (ocean currents, contact with marine life, etc.). The aluminium oxide is a very stable in neutral pH water. The basic anode depletion rates are outlined in Table 2-28.

Anodes are removed and replaced as required using divers/ROV.

Table 2-28: Anode depletion rates

Location	Daily depletion rate (kg/day)	Total depletion rate (kg)
WNB	2.18	15,900kg over 20 years
WNA	1.23	11,200kg over 25 years
PLEM/CALM Buoy flowlines	0.25	1,800kg over 20 years N/A

2.8.12 Flushing and leak testing

Hydrotesting, pressure and leak testing is undertaken to test the integrity of flowlines, risers, piping and any other components of the Wandoo Facility as part of the quality assurance process. This involves filling lines or vessels with seawater (treated with biocide and/or fluorescein dye) and pressurising to above operating pressure to assess whether there are any leaks.

Flushing is undertaken as part of testing or repairs with the flowline, piping or vessel flushed with treated seawater to send the oil and gas back to the process prior to removal or testing. The seawater is treated using biocide and occasionally the water is treated using a combination of biocide and corrosion inhibitor.

The treated seawater from flushing and testing activities is directed primarily to either storage or the PWTS.

2.8.13 Anchoring/mooring

Most of vessels working within the Wandoo Field maintain station using Dynamic Positioning (DP) Systems (either DP2 or DP3). Vessel(s) supporting the works may be required to anchor in the vicinity of the Wandoo Facility, this would involve the placement of up to three anchors on the sea floor.

Clump weights are also occasionally used as a temporary mooring for light vessels and during CALM Buoy maintenance work.

2.8.14 Spill response activities

Although the Wandoo oil production, storage and transfer activities are well understood and part of routine activities in the oil and gas industry, these activities pose a potential risk of a loss of containment. In order to mitigate impacts from a potential spill event resulting from oil production, storage and transfer activities, VOGA has an array of potential spill response strategies that may be implemented in the event of a spill.

2.8.14.1 Source control

Source control is one of the first response strategies that should be considered when mounting a spill response. Source control minimises the volume of hydrocarbons lost to the environment by regaining control at the source of the spill. In many cases, source control can be as simple as turning off a valve but may also be as complex as CGS repair.

2.8.14.2 Monitoring and evaluation

Monitoring and evaluation is a technique used to understand the behaviour and likely trajectory of an oil spill to assist with selecting the most appropriate spill response strategy and to evaluate results during the response process. Several methods can be used to monitor and evaluate, including:

- Surveillance from field infrastructure and vessels;
- Aerial surveillance;
- Satellite tracking buoys; and
- Oil spill trajectory modelling.

2.8.14.3 Chemical dispersion

Chemical dispersion involves the application of chemical dispersant which accelerates the natural dispersion process, causing the oil to break down into small droplets, which are then rapidly dispersed into the water column and away from the ocean surface where it can be more easily biodegraded. The objective of dispersant use is to enhance the amount of oil that physically mixes into the water column, reducing the potential for a surface slick to contaminate shoreline habitats or come into contact with birds, marine mammals or other marine fauna that exist on the water surface or shoreline.

2.8.14.4 Containment and recovery

Booms and skimming equipment can be used to create physical barriers on the water surface to contain and recover the oil spill where information (including predictive spill fate modelling) indicates a likely threat to environmental, social and cultural sensitivities. This strategy is often used in the offshore environment in close proximity to the hydrocarbon source. Once contained, an attempt to recover the hydrocarbons from the surface waters can be undertaken.

2.8.14.5 Mechanical dispersion

Mechanical dispersion is the use of fire monitors, engine wash or other means to mechanically/physically disperse spilled oil into the water column, thereby increasing the speed with which weathering and biodegradation occurs. This strategy is a secondary strategy for all spill categories that could result from activities associated with this EP.

2.8.14.6 Protection and deflection

The deployment of protection and deflection booms, along with a combination of sediment barriers and filter fences, can assist with minimising the potential impact and/or deflecting a slick away from sensitive areas towards those where collection can be more effective without impacting high value habitat areas.

2.8.14.7 Shoreline clean-up

Shoreline clean-up is the removal of oil from shorelines. Shorelines clean-up techniques that could be implemented in the event of an oil spill include:

- Natural recovery;
- Physical cleaning/remove/disposal;
- Physical cleaning/washing;
- Physical cleaning in-situ;
- Treatment; and
- Bioremediation.

2.8.14.8 Oiled wildlife response

Oiled wildlife response may consist of hazing, capture, recovery, assessment, cleaning and rehabilitation of oiled wildlife.

2.9 Decommissioning and unutilised assets

2.9.1 Assets

Vermilion maintains an asset register which contains assets list for items within the Wandoo Field (WA-14L). Following major projects where new equipment is added, for example well construction campaigns, the management of change process identifies updates required to the asset register. Equipment list is provided for in Section 2.9.4.

Asset management/maintenance of property is discussed further in Section 7.14.

2.9.2 Unutilised assets

Wandoo-1 well is the only unutilised subsea asset in Wandoo. Wandoo-1 well was the discovery well drilled in May 1991 which was suspended with downhole cement plugs as detailed in VOGA Wandoo-1 Well Operations Management Plan (VOG-1000-YG-007), however the wellhead remains on seafloor. Description of Wandoo-1 is provided Section 2.4.3.1 of this EP.

Wandoo-1 does not introduce any new hazard or any additional risk than those contemplated in Section 6 of this EP. As outlined in Table 6-1, physical presence is the only potential environmental impact and risk from Wandoo-1 well, however due to its size this is considered to be insignificant. This is discussed further in Section 6.21.

2.9.3 Decommissioning

VOGA does not plan to undertake any decommissioning activities within next 5 years.

Currently, there are no subsea or sea-surface assets in the field that are due for permanent removal prior to economic end of field life. There may be requirements under maintenance or repair activities to remove and replace, as contemplated within the Activity Description (Section 2.8).

2.9.4 Equipment list

Table 2-29 provides a list of equipment installed on permit WA-14-L for the purposes of exploration, field development and operation of the field. The equipment list below reflects the discrete equipment groups that are considered as standalone tasks in decommissioning. For example as decommissioning will involve the disconnection of WNA and WNB topsides from their respective structures as a unit (with topsides equipment attached), the individual process equipment on the topside is not listed in Table 2-29. VOGA will continue to manage this list and additional property added will be incorporated.

Table 2-29 Section 572 Equipment List

Item	Status	Inspection, Maintenance repair plans in place	EP Description (Section 2) Ref
Platform			
WNA Topside Structure	Currently utilised	In Place	2.4.1
WNA Substructure	Currently utilised	In Place	2.4.1
WNB Topside Structure and equipment	Currently utilised	In Place	2.4.2.3
WNB Substructure	Currently utilised	In Place	2.4.2.1 and 2.4.2.3
WNB CGS	Currently utilised	In Place	2.4.2.1 and 2.4.2.2

Item	Status	Inspection, Maintenance repair plans in place	EP Description (Section 2) Ref
WNA Wells (5) and external conductors (3)	Currently utilised	In Place	2.4.1 and 2.5.5
WNA riser caisson (1)	Currently utilised	In Place	2.4.1
WNB Wells (16), three more proposed	Currently utilised	In Place	2.5.5
WNB external conductors (4)	Three Currently utilised, one to be installed	In Place	2.4.2
Infield flow lines			
WNA – WNB Production Flow Line	Currently utilised	In Place	2.5.4
WNB – WNA Gas Lift Flow Line	Currently utilised	In Place	
WNA-WNB Test Line	Currently utilised- not used for hydrocarbon service	In Place	
Export System			
PLEM (Pipeline End Manifold)	Currently utilised	In Place	2.5.11.1
Export Flowlines (2)	Currently utilised	In Place	2.5.11.1
Mid Depth Buoyancy Tank	Currently utilised	In Place	2.5.11.1
Submarine Hose Assembly (SHA)	Currently utilised	In Place	2.5.11.1
Calm Buoy	Currently utilised	In Place	2.5.11.2
Floating Hose Assembly (FHA)	Currently utilised	In Place	2.5.11.1
Subsea Wells			
Wandoo 1	Suspended well	YES	2.4.3.1
Wandoo 2	P & A well	Not required	N/A
Wandoo 3	P & A well	Not required	
Wandoo 4	W-4 P&A, then W-4A redrilled, renamed as WNA 1	Not required	
Wandoo 5	P & A well	Not required	
Wandoo 6	P & A well	Not required	

Item	Status	Inspection, Maintenance repair plans in place	EP Description (Section 2) Ref
Wandoo 7	P & A well	Not required	
Wandoo North 1	P & A well	Not required	
Wandoo South 1	P & A well	Not required	
Enderby 1	P & A well	Not required	
Tingle 1	P & A well	Not required	
Whitewood 1	P & A well	Not required	

3. Description of project context

3.1 Potential Environmental Hazards

Based on the activities described in Section 2, the following potential environmental hazards have been identified for assessment and management:

Planned and unplanned interactions with the environment resulting from hydrocarbon production and export from the Wandoo facility; inspection and maintenance operations; and spill response activities:

- Physical presence of the infrastructure
- Disturbance to marine fauna and seabirds
- Seabed disturbance from maintenance operations
- Introduction of invasive marine pests

Emissions and discharges to the environment from routine Wandoo facility and vessel operations; and spill response activities:

- Discharge of produced formation water and ballast water
- Noise
- Atmospheric emissions
- Artificial light
- Discharge of cooling water
- Deck drainage and bilge water discharge
- Discharge of sewage, grey water and putrescible wastes
- Discharge of desalination brine
- Non-hazardous and hazardous waste
- Discharge of chemicals used for maintenance and inspection

Unplanned discharges to the environment during routine Wandoo facility and vessel operations:

- Liquid hydrocarbon release from wells
- Liquid hydrocarbon release from export equipment, submarine hose, floating hose or export flowlines
- Crude oil spill from CGS
- Liquid hydrocarbon release from topsides process
- Ancillary hydrocarbon or chemical spills
- Liquid hydrocarbon release from flow lines and risers

- Diesel spill to sea from vessel collision

Spill response specific interactions, discharges and emissions to the environment from the spill response activities.

The relationship between activities and environmental hazards is shown in Table 3-1, and between environmental hazards and project areas is shown in Table 3-2.



Table 3-1: Relationship between Activities and Environmental Hazards

EP risk no.	Hazard	Activity											
		Hydrocarbon production	Export of hydrocarbons	Support activities for operations	Maintenance, inspection and project activities (on Facility)	Maintenance, inspection and project activities	Spill response activities						
							Source Control	Monitoring and Evaluation	Chemical Dispersion	Containment and Recovery	Mechanical Dispersion	Shoreline Clean-up	Oiled Wildlife Response
EP-OP-R01	Liquid hydrocarbon release from wells	x		x	x	x							
EP-OP-R02	Liquid hydrocarbon release from export equipment, submarine hose, floating hose or export flow lines		x										
EP-OP-R03	Crude oil spill from CGS	x	x										
EP-OP-R04	Environmental impacts of oil spill response					x	x	x	x	x	x	x	x
EP-OP-R05	Diesel spill to sea			x	x	x	x						
EP-OP-R06	Discharge of PFW and ballast water from Facility	x											
EP-OP-R07	Noise			x	x	x	x	x	x	x			
EP-OP-R08	Atmospheric emissions	x	x	x	x	x	x	x	x	x			
EP-OP-R09	Artificial light	x	x	x	x	x	x	x	x				
EP-OP-R10	Discharge of cooling water from Facility			x									
EP-OP-R11	Vessel and Facility deck drainage and vessel bilge water discharge			x	x	x	x	x	x	x	x		
EP-OP-R12	Discharge of sewage, greywater and putrescible waste from Facility and vessels			x	x	x	x	x	x	x			
EP-OP-R13	Discharge of desalination brine			x									
EP-OP-R14	Non-hazardous and hazardous waste	x		x	x	x	x		x		x	x	
EP-OP-R15	Use and discharge of chemicals for maintenance and inspection activities				x	x	x				x	x	
EP-OP-R16	Disturbance to marine fauna and seabirds		x	x	x	x	x	x	x	x	x	x	
EP-OP-R17	Liquid hydrocarbon release from topsides process	x			x								
EP-OP-R18	Ancillary hydrocarbon or chemical spills	x		x	x	x	x						
EP-OP-R19	Physical presence of infrastructure	x	x	x	x	x	x						
EP-OP-R20	Seabed disturbance			x	x	x	x				x		
EP-OP-R21	Introduction of invasive marine pests		x	x	x	x	x	x	x	x			
EP-OP-R22	Liquid hydrocarbon release from flow lines and risers	x		x	x	x							



Table 3-2: Environmental Hazards within each Project Area

EP risk no.	Hazard	Impact / Risk	Project Areas		
			Operational Area & Mixing Zone	Hydrocarbon Area	EMBA
EP-OP-R01	Liquid hydrocarbon release from wells	Temporary decrease in marine water quality.	x	x	x
		Increased toxicity of, and bioaccumulation in, marine organisms from the ingestion of hydrocarbons. Injury or death of exposed marine fauna (e.g. oiling of seabirds). Habitat impacts where the spill reaches sensitive marine areas such as coral reefs or the shoreline.	x	x x x	
EP-OP-R02	Liquid hydrocarbon release from export equipment, submarine hose, floating hose or export flow lines	Temporary decrease in marine water quality.	x	x	x
		Increased toxicity of, and bioaccumulation in, marine organisms from the ingestion of hydrocarbons. Injury or death of exposed marine fauna (e.g. oiling of seabirds). Habitat impacts where the spill reaches sensitive marine areas such as coral reefs or the shoreline.	x	x x x	
EP-OP-R03	Crude oil spill from CGS	Temporary decrease in marine water quality.	x	x	x
		Increased toxicity of, and bioaccumulation in, marine organisms from the ingestion of hydrocarbons. Injury or death of exposed marine fauna (e.g. oiling of seabirds). Habitat impacts where the spill reaches sensitive marine areas such as coral reefs or the shoreline.	x	x x x	
EP-OP-R04	Environmental impacts of oil spill response	Increased entrained fraction of hydrocarbons in the water column after adding dispersants. Toxicity effects on marine fauna from dispersant. Disturbance to benthic habitat, adjacent vegetation and other environmentally sensitive areas. Scouring of sediments. Waste generation, disposal and management.		x x x x	
EP-OP-R05	Diesel spill to sea	Temporary decrease in marine water quality.	x	x	
		Increased toxicity of, and bioaccumulation in, marine organisms from the ingestion of hydrocarbons.	x	x	
EP-OP-R06	Discharge of PFW and ballast water from Facility	Temporary decrease in marine water quality.	x		
		Toxicity effects on marine fauna	x		
EP-OP-R07	Noise	Injury to hearing or other organs of marine fauna	x		
		Masking or interfering with biologically important sounds	x		
		Disturbance leading to behavioural changes or displacement of fauna	x		
EP-OP-R08	Atmospheric emissions	A localised and temporary reduction in air quality leading to the displacement or injury of avifauna. Contribution to global greenhouse gases.	x x	x	x
EP-OP-R09	Artificial light	Disorientation, attraction or repulsion of marine fauna and birds. Altered foraging and breeding behaviours including increased predation risk.	x x		
EP-OP-R10	Discharge of cooling water from Facility	Thermal impacts to marine organisms. Reduced dissolved oxygen concentrations and dilute hypochlorite content, leading to localised impacts on pelagic fauna. Toxicity effects to marine organisms in the immediate vicinity of the discharge.	x x x		
EP-OP-R11	Vessel and Facility deck drainage and vessel bilge water discharge	Reduction in water quality. Toxicity effects to marine organisms in the immediate vicinity of the discharge.	x x		
EP-OP-R12	Discharge of sewage, greywater and putrescible waste from Facility and vessels	Nutrient enrichment and increased biological demand of surrounding waters. Low level contamination of organisms caused by ingestion of waste materials. Increase in scavenging behaviour of marine fauna and seabirds.	x x x		



EP risk no.	Hazard	Impact / Risk	Project Areas		
			Operational Area & Mixing Zone	Hydrocarbon Area	EMBA
EP-OP-R13	Discharge of desalination brine	Localised elevation in seawater salinity. Localised reduction in water quality.	x x		
EP-OP-R14	Non-hazardous and hazardous waste	Marine pollution (litter). Injury and entanglement of marine fauna and seabirds. Potential toxicity effects to marine fauna.	x x x		
EP-OP-R15	Use and discharge of chemicals for maintenance and inspection activities	Reduced water quality. Toxicity effects to marine organisms.	x x		
EP-OP-R16	Disturbance to marine fauna and seabirds	Potential injury/death and/or temporary and localised displacement of listed and non-listed marine fauna or seabirds.	x		
EP-OP-R17	Liquid hydrocarbon release from topsides process	Temporary localised decrease in marine water quality. Increased toxicity of, and bioaccumulation in, marine organisms from the ingestion of hydrocarbons.	x x		
EP-OP-R18	Ancillary hydrocarbon or chemical spills	Temporary decrease in marine water quality. Increased toxicity of, and bioaccumulation in, marine organisms from the ingestion of hydrocarbons.	x x		
EP-OP-R19	Physical presence of infrastructure	Disturbance marine fauna including marine mammals, reptiles and birds. Interaction with commercial and recreational fishing and shipping. Provision of an artificial habitat for benthic and pelagic organisms.	x x x		
EP-OP-R20	Seabed disturbance	Seafloor scour. Increase in turbidity of the water column/reduction light penetration. Localised smothering of benthos. Localised reduction in benthic productivity.	x x x		
EP-OP-R21	Introduction of invasive marine pests	Changes to habitat structure. Predation of native species. Potential introduction of invasive marine species.	x x x		
EP-OP-R22	Liquid hydrocarbon release from flow lines and risers	Temporary localised decrease in marine water quality. Increased toxicity of, and bioaccumulation in, marine organisms from the ingestion of hydrocarbons.	x x		

3.2 Oil spill impact assessment methodology

3.2.1 Loss of Well Control

Based on the Safety Case and environmental hazard review workshops held, a well failure resulting in a loss of hydrocarbon could occur from the following activity/causes:

- Well intervention operations;
- Loss of well integrity;
- Structural failure of platform due to fatigue/ageing asset;
- Vessel collision with platform; and
- Dropped object or swinging load onto the wellhead.

As described in Section 2.5.3, Wandoo has a range of well types, some of which do not flow to atmosphere. For assessment of this hazard, current and proposed production wells which can flow to atmosphere at surface were reviewed, to determine a conservative worst-case discharge.

The review (Technical Report WNB-7500-RG-0002) was based on Vermilion's understanding of Wandoo reservoir physical conditions and properties along with dynamic reservoir simulation, with no obstructions or flow restrictions in the well, in accordance with the methodology of the Society of Petroleum Engineers (SPE) Technical Report: Calculation of Worst-Case Discharge (WCD) (April 2015).

The use of current and proposed production wells is considered representative for future production wells given that reservoir pressure is declining over time, and each infill development well design for Wandoo is consistent with the Well Construction Manual.

Vermilion applied conservative assumptions to this assessment, utilising our understanding of previous and proposed well designs and reservoir conditions to reasonably capture future wells within the assumed spill rate and duration.

To ensure that the flow rate and duration of a blowout for any new wells proposed in Wandoo Field remain within the worst-case discharge parameters, new wells will be assessed prior to drilling using reservoir simulation modelling.

3.2.2 CGS Spill

As outlined in Section 2.4.2, crude oil produced on Wandoo is stored in two storage cells within the CGS. It has a combined capacity of approximately 68,400m³ (430,000bbls), with the largest storage cell with a storage volume of 39,747m³.

The storage of hydrocarbons carries an inherent risk of spills, which needs to be managed. The hazard review identified the following credible causes of a release from the CGS:

- Degradation/collapse of the CGS shaft due to fatigue, corrosion of steel reinforcement, extreme storm;
- Impact from a colliding vessel; and
- Tanker station keeping failure.

This EP considers the worst-credible case to be a release from the largest cell (39,747m³) over a period of 24 hours. As detailed structural modelling was required to determine leak rates based on crack propagation and structural failure modes, VOGA has elected to conservatively estimate the total spill size and duration.

In the event of a loss of integrity of the CGS, the system is designed to be under a lower pressure than its seawater surroundings. This means that should a crack propagate across the 875mm thick reinforced concrete between the sea and oil storage, water will first enter the storage cell. Once the pressure is balanced, oil can only migrate through gravitation forces (buoyancy). For small cracks this means that the leak rate will be very low.

This hazardous event is based on a full storage cell, which is not a consistent operating mode; the ratio of which depends on production rates and cargo sizes of previous offtake operations. During the export operation, the exported oil is replaced with ballast water in the CGS. As production continues, crude oil will displace the ballast water. Therefore, on most occasions the CGS base will contain both ballast water and crude oil.

3.2.3 Assessment of spill trajectory

Oil spill modelling is required to determine the potential spatial and temporal extent of exposure associated with an unplanned release of reservoir hydrocarbons to the marine environment.

Oil Spill Trajectory Modelling (OSTM) was used to assess the potential environmental impacts of the worst-case Wandoo Crude oil spill associated with the operation of the Wandoo Facility, based on the latest reservoir modelling information available to VOGA and the storage capacity of the Wandoo Facility concrete gravity structure (CGS). Details regarding the oil spill modelling undertaken by RPS to support this EP are provided below and in Appendix 3.

OSTM was undertaken for the following two worst-case discharge (WCD) scenarios (RPS, 2020):

- Scenario 1: a 4,364 m³ (or 31,692 bbl) surface release of Wandoo crude 10 days after the incident starts for 68 days, to represent an unrestricted loss of well control;
- Scenario 2: a 39,750 m³ (or 250,000 bbl) subsea release of Wandoo crude over 24 hours, to represent an unrestricted loss of CGS containment.

The scenarios were modelled using summer, winter and transitional wind and current conditions. Modelling outputs were used to predict the probability and the number of days for specific hydrocarbon threshold concentrations to contact identified values and sensitivities.

The environment that may be affected (EMBA) for the Wandoo Field operational activities is based on the modelling results for Scenario 2 after evaluation with the results from Scenario 1 identified the spatial extent of Scenario 2 encompassing Scenario 1.

Worst case for oil spill response planning was evaluated by considering the results for both scenarios – with scenario 1 worst case for duration and scenario 2 for volume of oil and time to impact due to its instantaneous nature.

To determine the potential benefit of applying dispersant across different seasons, the 100 simulations for scenario 1 were remodelled under identical conditions with surface dispersant applied continuously for 10 hours during daylight, 48 hours after the initial release until the end of the spill duration. Dispersant application was assumed to be limited to a 40 km by 40 km zone centred on the release location, but with a 500m exclusion zone around WNA, WNB, Stag

Platform and a potential relief well location within 3km of WNB. A conservative dispersant to oil ratio of 1:20 and effectiveness of 50% was utilised.

3.2.4 Diesel spill

Potential impacts in the unlikely event of vessel to vessel collision resulting in a fuel tank rupture are described in the National Energy Resources Australia (NERA) Consequence Analysis of an Accidental Release of Diesel Reference Case (NERA, 2018). This is based on conservative modelling outputs. Refer to Section 6.6 for details.

3.3 Produced Water Discharge Impact Assessment Methodology

3.3.1 Overview

An overview of the impact assessment methodology is presented in Figure 3-1.

The environmental impact of PFW as a whole effluent was assessed along with the environmental impact of the individual components of PFW as part of a Produced Formation Water Environmental Impact Assessment (AE15009-VOG-1000-RH-0002).

PFW contains components that have the potential to impact the environment, specifically:

- hydrocarbons
- ammonia
- heavy metals
- radionuclides
- production chemicals, and
- physical properties (i.e. temperature)

Impact assessment criteria were developed for PFW as a whole and for each of the PFW components using best practice guidance, legislative limits, and the results of previous PFW monitoring.

Note that the assessment criteria utilised for PFW whole effluent and components have been reviewed and updated from the previous Produced Formation Water Environmental Impact Assessment (AE15009-VOG-1000-RH-0002) documented in Revision 12 of the EP as part of the 2017/18 PFW Upgrade.

The potential extent of exposure, in terms of both distance and area, for PFW as a whole and each component was established for both the current and proposed scenarios using modelling results and dilution plots.

The results of modelling, PFW chemistry monitoring and field environmental monitoring were used to determine the potential impacts of each component of the PFW at both the current flow rate and proposed flow rate (Section 6.7.3). The outcomes of this impact assessment were then used to determine the overall impact of PFW at the proposed flow rate.

PFW and the key components of PFW, being hydrocarbon and ammonia, were modelled for all seasons to determine the potential area of exposure at the current flow rate and proposed flow rate.

3.3.2 Modelling Methodology

Discharge occurs below the water surface through a single outlet. Modelling inputs are outlined in Table 3-3.

Table 3-3 Modelling inputs

Parameter	Inputs
Depth of discharge below surface	8 m
Internal diameter of outlet	0.575 m
Salinity	29.2 ppt
Temperature	52°C

The modelling study was carried out as three independent, yet integrated stages. Firstly, current data for the study area was generated which included the combined influence of ocean and tidal currents. Secondly, a near-field discharge model (UM3) was used to assess the rate of temperature and dilution of the plume for the different flow rates seasonal weak, medium and strong constant currents strengths. Finally, the generated currents and near-field mixing estimates were used as input into MUDMAP to predict the varying nature of currents, together with the potential for recirculation of the plume back to the discharge location.

The modelling is considered conservative based on the following methodology and inputs utilised:

- Based on a conservative tracer method that accounts for the influence of physical processes (i.e. transport, dispersion and mixing that influences dilution) and excludes biochemical processes.
- The horizontal and vertical dispersion coefficients applied are reflective of weaker currents and therefore conservative as during strong currents there would be greater degree of sub-scale (or turbulent) mixing occurring.

Field validation of the modelling was undertaken in 2015 (refer Section 6.7.4.1).

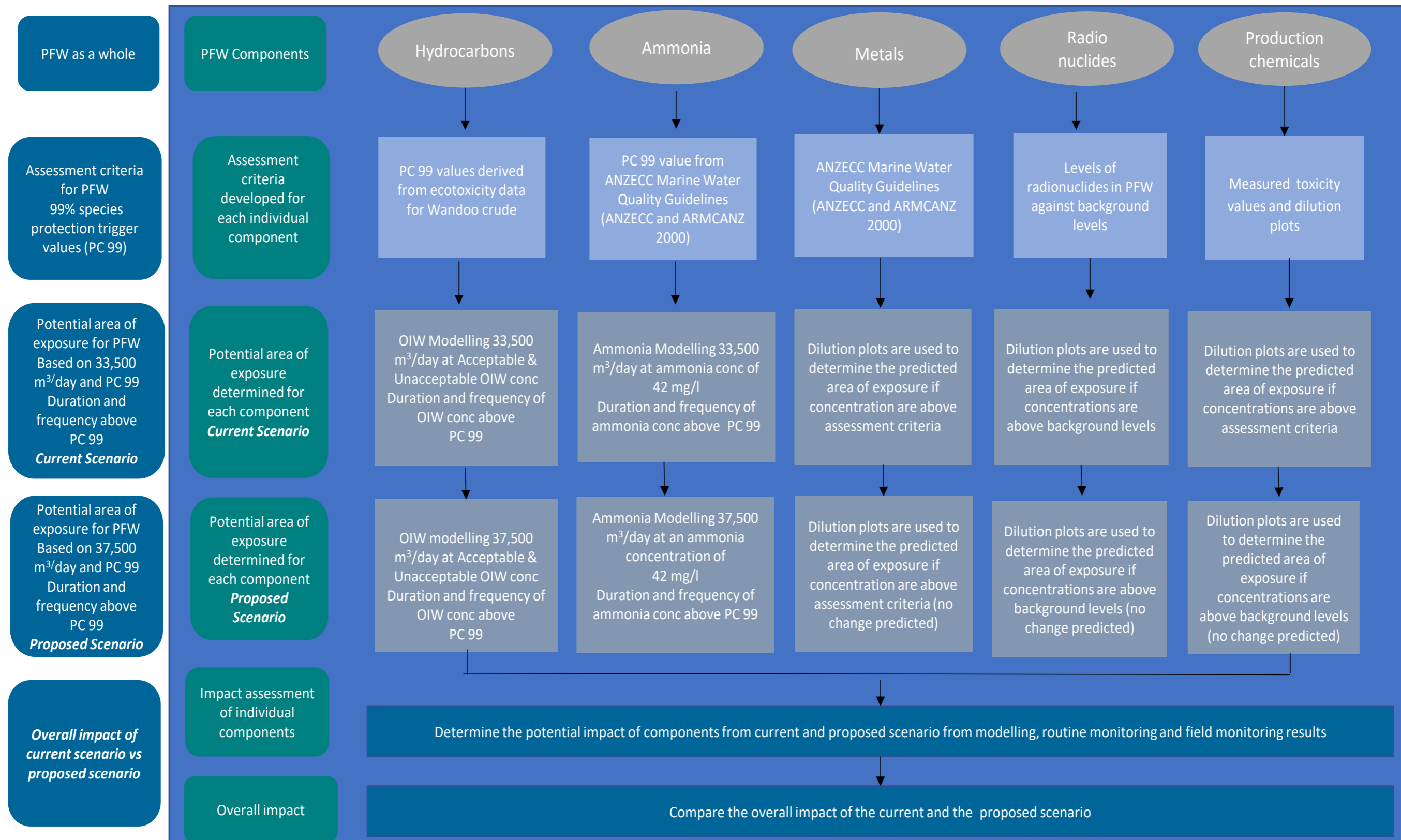

Figure 3-1: Produced Water Impact assessment methodology

3.3.3 Impact Assessment Criteria

3.3.3.1 Whole Effluent

The environmental impact of PFW as a whole effluent was determined by calculating the potential area of exposure based on 99% species protection trigger values derived from ecotoxicity testing undertaken in 2017 (Table 3-4) which is supported by ecotoxicity screening test results from both 2018 and 2020. Protecting 99% of species maintains a high level of ecological protection at the boundary of the potential area of exposure.

Table 3-4 Threshold and dilution factors for 99% species protection

Level of species protection	Initial Concentration	Trigger values (% sample)	Dilutions required
99%	100%	0.39	256

3.3.3.2 Hydrocarbons

There are two potential impact pathways present in the PFW that result from interaction with hydrocarbons:

- Dissolved oil
- Dispersed (entrained) oil

Dissolved oil

The primary pathway that is assessed using laboratory-based direct toxicity assessment (DTA) testing relates to the dissolved or soluble components within the PFW.

Laboratory studies have shown that dissolved hydrocarbons exert most of the toxic effects of oil on aquatic biota (Carls et al., 2008; Nordtug et al., 2011; Redman, 2015). The mode of action is a narcotic effect, which is positively related to the concentration of soluble hydrocarbons in the body tissues of organisms (French-McCay, 2002). Dissolved hydrocarbons are taken up by organisms directly from the water column by absorption through external surfaces and gills, as well as through the digestive tract. Thus, soluble hydrocarbons are termed “bioavailable”.

Hydrocarbon compounds vary in water-solubility and the toxicity exerted by individual compounds is inversely related to solubility, however bioavailability will be modified by the volatility of individual compounds (Nirmalakhandan & Speece, 1988; Blum & Speece, 1990; McCarty, 1986; McCarty et al., 1992a, 1992b; Mackay et al., 1992; McCarty & Mackay, 1993; Verhaar et al., 1992, 1999; Swartz et al., 1995; French-McCay, 2002; McGrath et al., 2009).

Of the soluble compounds, the greatest contributor to toxicity for water-column and benthic organisms are the lower-molecular-weight aromatic compounds, which are both volatile and soluble in water. Although they are not the most water-soluble hydrocarbons within most oil types, the polynuclear aromatic hydrocarbons (PAHs) containing 2-3 aromatic ring structures typically exert the largest narcotic effects because they are semi-soluble and not highly volatile, so they persist in the environment long enough for significant accumulation to occur (Anderson et al., 1974, 1987; Neff & Anderson, 1981; Malins & Hodgins, 1981; McAuliffe, 1987; NRC, 2003).

The monoaromatic hydrocarbons (MAHs), including the BTEX compounds (benzene, toluene, ethylbenzene, and xylenes), and the soluble alkanes (straight chain hydrocarbons) also contribute to toxicity, but these compounds are highly volatile, so that their contribution will be low when oil is exposed to evaporation and higher when oil is discharged at depth where volatilisation does not occur (French-McCay, 2002).

French-McCay (2002) reviewed available toxicity data, where marine biota was exposed to dissolved hydrocarbons prepared from oil mixtures, finding that 95% of species and life stages exhibited 50% population mortality (LC50) between 6 and 400 ppb total PAH concentration after 96 hrs exposure, with an average of 50 ppb. Early life-history stages of fish appear to be more sensitive than older fish stages and invertebrates.

A more conservative 99% species protection trigger value for dissolved oil of 16 ppb was utilised based on toxicity testing of the Wandoo crude (Intertek, 2019) (Table 3-5).

Dispersed (Entrained) oil

The second pathway is dispersed oil in the water column, also termed entrained oil.

Entrained hydrocarbons consist of oil droplets that are suspended in the water column and insoluble. As such, insoluble compounds in oil cannot be absorbed from the water column by aquatic organisms, hence are not bioavailable through absorption of compounds from the water. Exposure to these compounds would require routes of uptake other than absorption of soluble compounds. The route of exposure of organisms to whole oil alone include direct contact with tissues of organisms and uptake of oil by direct consumption, with potential for biomagnification through the food chain (NRC, 2005).

A conservative threshold for dispersed oil has been utilised from the 'OSPAR Establishment of a list of Predicted No Effect Concentrations (PNECs) for naturally occurring substances in produced water' (OSPAR Agreement 2014-05) where a 99% species protection trigger value of 70.5 ppb has been established (Table 3-5).

This is conservative as the receptors are biomarkers, which are generally more sensitive than whole organism tests.

Table 3-5 Threshold for hydrocarbons

Oil Phase	Level of species protection	Threshold (ppb of OIW)	Source
Dissolved	99%	16	Wandoo Crude Ecotox (Intertek, 2020)
Dispersed (Entrained)	PNEC	70.5	OSPAR Report (2014)

Frequency and duration of exposure

The frequency and duration of exposure of key sensitivities to concentrations above the threshold values can be an important consideration in determining the level of impact.

The area of exposure plots does not account for the frequency and duration when threshold concentrations are exceeded at the proposed flow rate. These plots are conservative and additional analysis was performed to determine:

- the number of continuous hours the OIW concentration was above thresholds at various distances from the platform over a 30-day period (Analysis 1), and
- the percentage of time the OIW ammonia concentration exceeds thresholds over a 30-day period (Analysis 2), and

Assessment criteria for the duration of exposure is based on the timeframes for previous DTA analysis of the PFW. The DTA analysis shows that the PFW is toxic to various species when tested under laboratory conditions over periods ranging from a minimum of one hour. Impacts to species are highly unlikely when exposed to OIW concentrations above the thresholds for periods of one hour or less. Impacts were also considered highly unlikely if the percentage of time the threshold concentration was exceeded over a 30-day period was below 1%.

3.3.3.3 Metals

Concentrations of metals above certain levels can cause environmental impacts. The impact assessment criteria for metals are based on the ANZECC water quality guidelines 99% and 95% species protection levels (ANZECC & ARMCANZ, 2018).

When concentrations exceeded the ANZECC 99% species protection levels, dilution plots were used to calculate where the ANZECC 99% species protection value (ANZECC & ARMCANZ, 2018) is achieved in proximity to the platform.

3.3.3.4 Ammonia

The impact assessment criteria for ammonia are based on the ANZECC water quality guidelines 99% and 95% species protection levels (ANZECC & ARMCANZ, 2018) (Table 3-6).

The initial concentration was based on the average results of monthly testing during 2018 and 2019.

Table 3-6 Threshold and dilution factor for ammonia

Level of species protection	Initial Concentration	Trigger values (% sample)	Dilutions required
99%	42	0.5	84

Frequency and duration of exposure

The frequency and duration of exposure of key sensitivities to ammonia concentrations above the threshold were assessed in line with the approach for hydrocarbons detailed in this section.

3.3.3.5 Radionuclides

Naturally occurring radioactive materials (NORMs) are present within geological formations and are typically found in sand and produced water brought to the surface during production. Within produced water the most abundant radionuclides are 226Ra and 228Ra which are derived from the radioactive decay of 238U and 232Th, respectively (Bou-Rabee et al., 2009). The half-lives of 226Ra and 228Ra are 1,601 and 5.7 years, respectively (Neff et al., 2011).

When PFW is brought to the surface with the oil, sand and gas, the rapid drop in temperature and pressure causes NORMs (primarily 226Ra and 228Ra) to precipitate out, which may result in accumulation of sludge and hard scales in the processing equipment (OGP, 2005). However,

226Ra and 228Ra may also remain dissolved within PW. Other radionuclides have been identified in PW including 212Bi, 214Bi, 228Ac, 210Pb, 212Pb and 214Pb, however, activities of these radionuclides are typically lower in PW than that of 226Ra and 228Ra (Bou-Rabee et al., 2009).

A review of the 226Ra and 228Ra concentrations in PFW by Neff et al. (2011) across discharges worldwide indicates that 226Ra activity ranges from 0.002 to 1,119 Bq/L and 228Ra activity ranges from 0.3 to 180 Bq/L. Natural levels within ocean surface waters of 0.001–0.0015 Bq/l and 0.0002–0.0011 Bq/L for 226Ra and 228Ra, respectively have been reported (Neff et al., 2011).

3.3.3.6 Production chemicals

Specific toxicity values for specific water-soluble production chemicals are used as impact assessment criteria (Table 3-7). The toxicity values are based on product ecotoxicity testing for a minimum three species with an addition of a 10 fold assessment factor to the LC50 data for conservatism in accordance with ANZECC (2000) guidance.

The concentration of the production chemicals in the PFW discharge is calculated. If this concentration exceeded toxicity values, dilution plots were used to calculate where the conservative toxicity values were achieved in proximity to the platform. If new production chemicals are required, they will be selected in accordance with the chemical assessment process outlined in this EP (Section 7.11).

Table 3-7 Toxicity values and maximum concentrations for production chemicals

Production chemical	Product toxicity threshold (including assessment factor)	Maximum concentration rates (in PFW discharge)
Corrosion inhibitor (CRW24060)	0.1 mg/l	25 mg/l
Oxygen scavenger (OSW24514)	10 mg/l	5 mg/l
Water clarifier (RBW24303)	0.17 mg/l	30 mg/l
Reverse demulsifier (RBW24362)	100 mg/l	12 mg/l
Scale inhibitor (SCW24069)	50 mg/l	5 mg/l
Forward demulsifier (DMO86539)	3 mg/l	10 mg/L (total produced fluids)

3.3.3.7 Temperature

The assessment criteria for temperature is based on the Environmental Health and Safety Guidelines for Offshore Oil and Gas Development (IFC, 2007). These guidelines recommend a temperature increase of no more than 3°C within 100 m of the discharge point.

3.4 Project Areas

Project Areas are the different areas, or zones, defined for this EP as areas of potential hazard or exposure to receptors. Some environmental hazards have been grouped within the same area, where the receptors affected, and the potential spatial boundary of the impacts are similar. Other environmental hazards, such as those associated with exposure from a hydrocarbon spill, have a specific project area defined.

The existing environment within each project area is described in Section 4. The nature and scale of the information provided in the description of the environment depends upon the potential

environmental hazards which may occur within that project area, and their scope for exposure to affected receptors. For this EP, the following Project Areas have been defined:

- Environment that may be Affected (EMBA) – the area within which a change in ambient environmental conditions could occur as a result of planned or unplanned activities (Figure 3-2). The EMBA is has been defined based on the combined outcomes of stochastic modelling for each WCD scenario (i.e. cumulative extent of a total of 100 model simulations per season for both scenarios) using low exposure values for each of the modelled oil components (1 g/m² floating, 10 ppb dissolved, 10 ppb entrained, 10 g/m² shoreline) which are threshold levels used to establish the range of socio-economic effects and establishes planning area for scientific monitoring based on potential for exceedance of water quality triggers.
- Hydrocarbon Area – this area has been defined to include the worst-case extent of predicted hydrocarbon exposure from planned and unplanned activities at exposure values that may have ecological or social impacts. The Hydrocarbon Area has been defined based on the combined outcomes of stochastic modelling for each WCD scenario (i.e. cumulative extent of a total of 100 model simulations per season for both scenarios) using moderate exposure values for each of the modelled oil components (10 g/m² floating, 50 ppb dissolved, 100 ppb entrained, 100 g/m² shoreline) which are threshold levels anticipated to result in behavioural changes and sub-lethal and lethal effects to biota) and includes all probabilities of exposure.
- Operational Area – the physical footprint area in which planned activities, as described in Section 2 of this EP, will occur. Defined as the area within the existing Petroleum Safety Zone (PSZ) within the Permit Area of WA-14-L (Figure 3-2) around the Wandoo facility.
- Mixing Zone – the extent of the potential impacts of planned activities. Defined as a 3.7 km radius around the WNB platform and based on the maximum distance for the produced water discharge to achieve PC99 species protection value (refer Section 6.7).

Environmental hazards have the potential to result in impacts or risks to environmental receptors, if they are present within the spatial or temporal boundaries of the environmental hazard.

By using the defined Project Areas, it is possible to identify receptors which may typically be impacted, depending on behaviour. This process guides the nature and scale of details provided in the Description of the Existing Environment, ensuring that our understanding of receptors within the Existing Environment of each Project Area is sufficient to undertake the impact assessment.

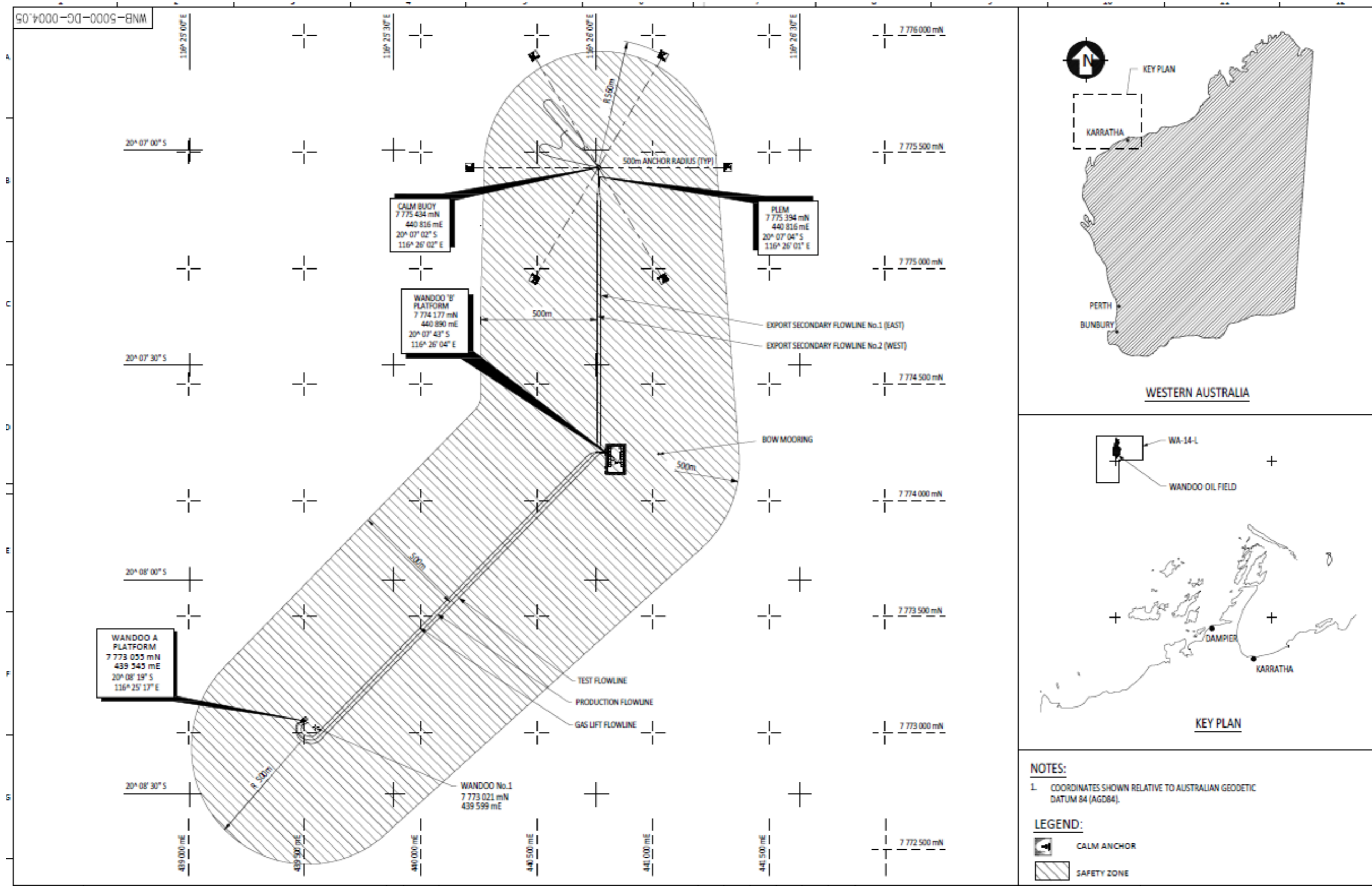

Figure 3-2: Operational Area of the Wandoo facility

3.5 Environmental Performance Outcomes

Based on the review of activities, aspects and related impacts and risks, VOGA has set the following overarching Environmental Performance Outcomes (EPOs) (Table 3-8) to set the overarching performance level to manage operational activities. These EPOs have been devised using the methodology description in Section 5.9, and are linked to the sensitive receptors potentially affected by each hazard.

Table 3-8 Environmental Performance Outcomes

Sensitive Receptor	EPO Identifier	Environmental Performance Outcome
Physical Environment (Section 4.5.1)		
Ambient water quality Ambient sediment quality Air quality Ambient noise Ambient light	EPO-OP-01	No substantial change in water quality, sediment quality, air quality, ambient noise or ambient light which may adversely impact on biodiversity, ecological integrity, social amenity or human health.
Climate	EPO-OP-02	No substantial contribution to climate change
Key Marine Habitats (Section 4.5.2) and Key coastal communities (Section 4.5.3)		
Subtidal soft sediment Corals Seagrasses Macroalgae Magroves Saltmarsh Intertidal beaches / mudflats Rocky shorelines / intertidal reef platforms Sandy beaches	EPO-OP-03	No change in water quality that may modify, destroy, remove, isolate or decrease the availability or quality of habitat to the extent that the Listed Threatened Species is likely to decline.
Key Marine Fauna (Section 4.5.4)		
Plankton Benthic Invertebrates	EPO-OP-04	No change that may modify, destroy, fragment, isolate or disturb an important or substantial area of habitat such that an adverse impact on marine ecosystem functioning or integrity in a Commonwealth or State marine area.
Birds Fish and sharks Marine mammals Marine reptiles	EPO-OP-05	No long-term decrease in the size or area of occupancy of a Critically Endangered/Endangered species population or fragment an existing population.
	EPO-OP-06	No change that may have a substantial adverse effect on habitat critical to the survival of a Listed Threatened Species.
	EPO-OP-07	No change that may substantially disrupt the breeding cycle of a Listed Threatened Species population.
	EPO-OP-08	No change that may interfere with the recovery of the Listed Threatened Species.
	EPO-OP-09	No change that may substantially modify, destroy or isolate an area of important habitat for a migratory species.

Sensitive Receptor	EPO Identifier	Environmental Performance Outcome
	EPO-OP-10	No change that may seriously disrupt the lifecycle (breeding, feeding, migration or resting behaviour) of an ecologically significant proportion of the population of a migratory species.
	EPO-OP-11	No change that may have a substantial adverse effect on a population of a non-listed marine species including its life cycle (for example, breeding, feeding, migration behaviour, life expectancy) and spatial distribution.
Marine mammals	EPO-OP-12	No displacement of blue whales/pygmy blue whales from their foraging BIAs.
Marine reptiles	EPO-OP-13	No displacement of marine turtles from their nesting/interesting BIAs.
Introduced marine species	EPO-OP-14	No introduction of an invasive species that are harmful to a Listed Threatened or migratory species becoming established in the species' habitat / or result in a known or potential pest species becoming established in the Commonwealth marine area.
Social and economic environment (Section 4.6)		
Fisheries and aquaculture Commercial shipping Defence Other users	EPO-OP-15	No interference with other marine users to a greater extent than is necessary for the exercise of right conferred by the titles granted.
	EPO-OP-16	No substantial change in water quality, sediment quality, air quality or biota which may adversely impact the function, interests or activities other marine users.
Values and Sensitivities (Section 4.7)		
Commonwealth Protected Areas State Marine Protected Areas Wetlands of international importance Key Ecological Features Theatened Ecological Communities	EPO-OP-17	No change that may have a substantial adverse effect on the protection and conservation of biodiversity, ecological processes and other natural, cultural and heritage values of marine parks and protected areas.
World Heritage Areas	EPO-OP-18	No change that may cause one or more of the World Heritage values of a declared World Heritage property to be lost, degraded or damaged, or notably altered, modified, obscured or diminished.
National Heritage Properties	EPO-OP-19	No change that may cause one or more of the National Heritage values of a National Heritage place to be lost, degraded or damaged, or notably altered, modified, obscured or diminished.
Commonwealth Heritage Places Underwater Cultural Heritage	EPO-OP-20	No substantial impact to heritage values or social surroundings, including damage or destruction of a historic shipwreck.

4. Description of the environment

4.1 Overview

The OPPGGG(E)R define 'environment' as the ecosystems and their constituent parts, natural and physical resources, qualities and characteristics or areas, the heritage value of places and includes social, economic and cultural features of those matters. In accordance with the Regulations, the Description of the Environment describes the ecological and social components of the environment relevant to the activity and achieves the following:

- Provides adequate information about the environment that may be affected (EMBA) by the activity in sufficient detail to inform the evaluation of environmental impacts and risks. This includes the environment that may be affected by planned components of the activities, and the area that may be exposed during unplanned events such as a hydrocarbon spill;
- Adequately defines the environment that may be exposed to hydrocarbons in the event of a significant incident and the geographic extent of response and monitoring activities;
- Provides sufficient detail regarding relevant threatened or migratory species and their defined biologically important areas (BIA) and/or habitat critical for species survival;
- Identifies all values and sensitivities (if any) within the environment including matters protected under Part 3 of the EPBC Act; and
- Enables relevant persons and members of the public to understand the environmental values and sensitivities that may be affected by the activity.

Using the Project Areas described in Section 3.4, the nature and scale of information provided in this section has been determined to ensure that adequate information is provided to support the assessment of impacts and risks associated with the scope of this EP.

4.2 Environment that May Be Affected

Operational activities are undertaken by VOGA at the Wandoo field within Permit WA-14-L, which is located in Commonwealth waters in the Carnarvon Basin off the northwest coast of Western Australia (WA), approximately 80 km northwest of Dampier and 110 km northeast of Barrow Island. The Operational Area and Mixing Zone lie within the Northwest IMCRA Province.

The environment that may be affected (EMBA) for the Wandoo Field operational activities has been defined by a spatial area within which a change to the ambient environmental conditions may occur as a result of planned or unplanned activities (Section 6). It is noted that changes in ambient conditions, as defined for the EMBA, does not imply that an adverse impact will occur. The EMBA within the Wandoo field extends from approximately Cape Naturaliste to the Kimberley region of WA to the southern islands of Indonesia including Java, Penida Island, Lombok, West Nusa Tenggara, East Nusa Tenggara, Sumba, Suwa Island and Timor, and offshore to Christmas and Cocos Islands. This represents the range of potential socio-economic impacts and establishes the planning area for scientific monitoring based on potential for exceedance of water quality triggers (NOPSEMA, 2019).

For the purposes of this EP, the defined EMBA associated with operational activities at the Wandoo Field has been split into different Project Areas which are used to support the impact and risk assessment process. Project Areas are described in Section 3.4.

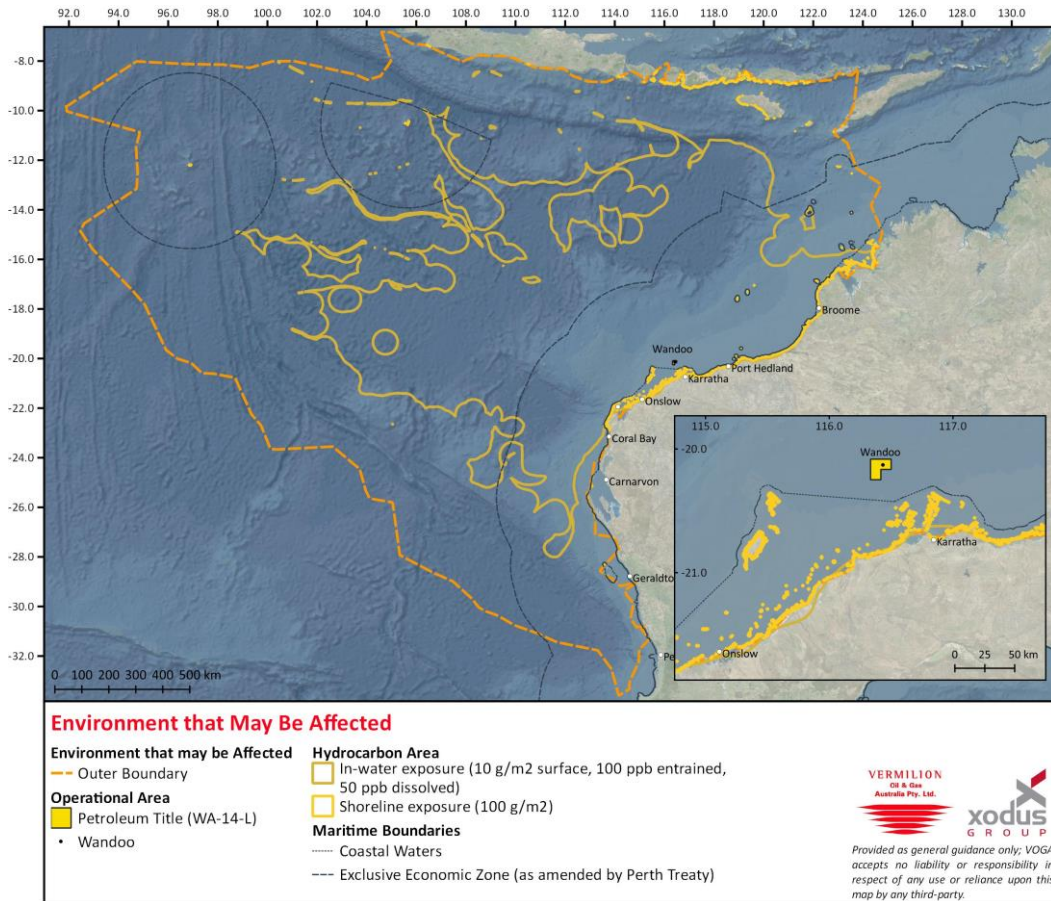

Figure 4-1 Environment that May be Affected

A separate protected matters search was undertaken for the EMBA and Hydrocarbon Area, and the combined Operational Area and Mixing Zone (given the Mixing Zone encompasses the Operational Area and both areas are in close proximity) in December 2020 and these are provided in Appendix 6.

For each receptor or receptor group known to occur within the defined Project Areas, their presence / absence is identified in Table 4-1. This, combined with the understanding of how each receptor is affected by environmental hazards (as listed in Table 3-2), guides the nature and scale of information provided throughout Section 4. Receptors identified in this section may have associated threat abatement plans, threatened species recovery plans and species conservation advices which are detailed in Section 1.6.

Table 4-1: Receptor presence or absence within Project Areas

Receptor Group	Operational Area & Mixing Zone	Hydrocarbon Area	EMBA
Physical Environment	<ul style="list-style-type: none"> Ambient water quality Ambient sediment quality Ambient air quality Climate Ambient noise Ambient light 	<ul style="list-style-type: none"> Ambient water quality Ambient sediment quality 	<ul style="list-style-type: none"> Ambient water quality Ambient sediment quality
Key marine habitats	<ul style="list-style-type: none"> Subtidal soft sediment and benthic fauna 	<ul style="list-style-type: none"> Subtidal soft sediment and benthic fauna Corals Seagrasses Macroalgae 	<ul style="list-style-type: none"> Subtidal soft sediment and benthic fauna Corals Seagrasses Macroalgae
Key coastal communities	<ul style="list-style-type: none"> None 	<ul style="list-style-type: none"> Mangroves Saltmarsh Intertidal beaches/mudflats Rocky shorelines/intertidal reef platforms Sandy beaches 	<ul style="list-style-type: none"> Mangroves Saltmarsh Intertidal beaches/mudflats Rocky shorelines / intertidal reef platforms Sandy beaches
Key marine fauna	<ul style="list-style-type: none"> Plankton Benthic invertebrates Birds Fish and sharks Marine mammals Marine reptiles 	<ul style="list-style-type: none"> Plankton Benthic invertebrates Birds Fish and sharks Marine mammals Marine reptiles 	<ul style="list-style-type: none"> Plankton Benthic invertebrates Birds Fish and sharks Marine mammals Marine reptiles
Social and economic environment	<ul style="list-style-type: none"> Fisheries and aquaculture Commercial shipping 	<ul style="list-style-type: none"> Fisheries and aquaculture Commercial shipping Defence Other users 	<ul style="list-style-type: none"> Fisheries and aquaculture Commercial shipping Defence Other users

Receptor Group	Operational Area & Mixing Zone	Hydrocarbon Area	EMBA
Values and Sensitivities	<ul style="list-style-type: none"> None 	<ul style="list-style-type: none"> World Heritage Areas National Heritage Properties Commonwealth Heritage Places Underwater Cultural Heritage Commonwealth Protected Areas State Marine Protected Areas Wetlands of International Importance Key ecological features Threatened ecological community 	<ul style="list-style-type: none"> World Heritage Areas National Heritage Properties Commonwealth Heritage Places Underwater Cultural Heritage Commonwealth Protected Areas State Marine Protected Areas Wetlands of International Importance Key ecological features Threatened ecological community

4.3 Regional Context

Regional descriptions relevant to the Project Areas as shown in Table 4-2 and Figure 4-2 are provided in the sections below.

Table 4-2: Relevant regions to the Project Areas

Receptor Group	Operational Area & Mixing Zone	Hydrocarbon Area	EMBA
North-west Marine Region	X	X	X
South-west Marine Region		X	X
Outside Australian EEZ		X	X
IMCRA Bioregions			
Central Western Province		X	X
Central Western Shelf Province		X	X
Central Western Shelf Transition		X	X
Central Western Transition		X	X
Christmas Island Province		X	X
Cocos (Keeling) Island Province		X	X
Northwest Province		X	X
Northwest Shelf Province	X	X	X
Northwest Shelf Transition		X	X
Northwest Transition		X	X

Receptor Group	Operational Area & Mixing Zone	Hydrocarbon Area	EMBA
Southwest Shelf Transition			X
Southwest Transition			X
Timor Province		X	X

X= present within area

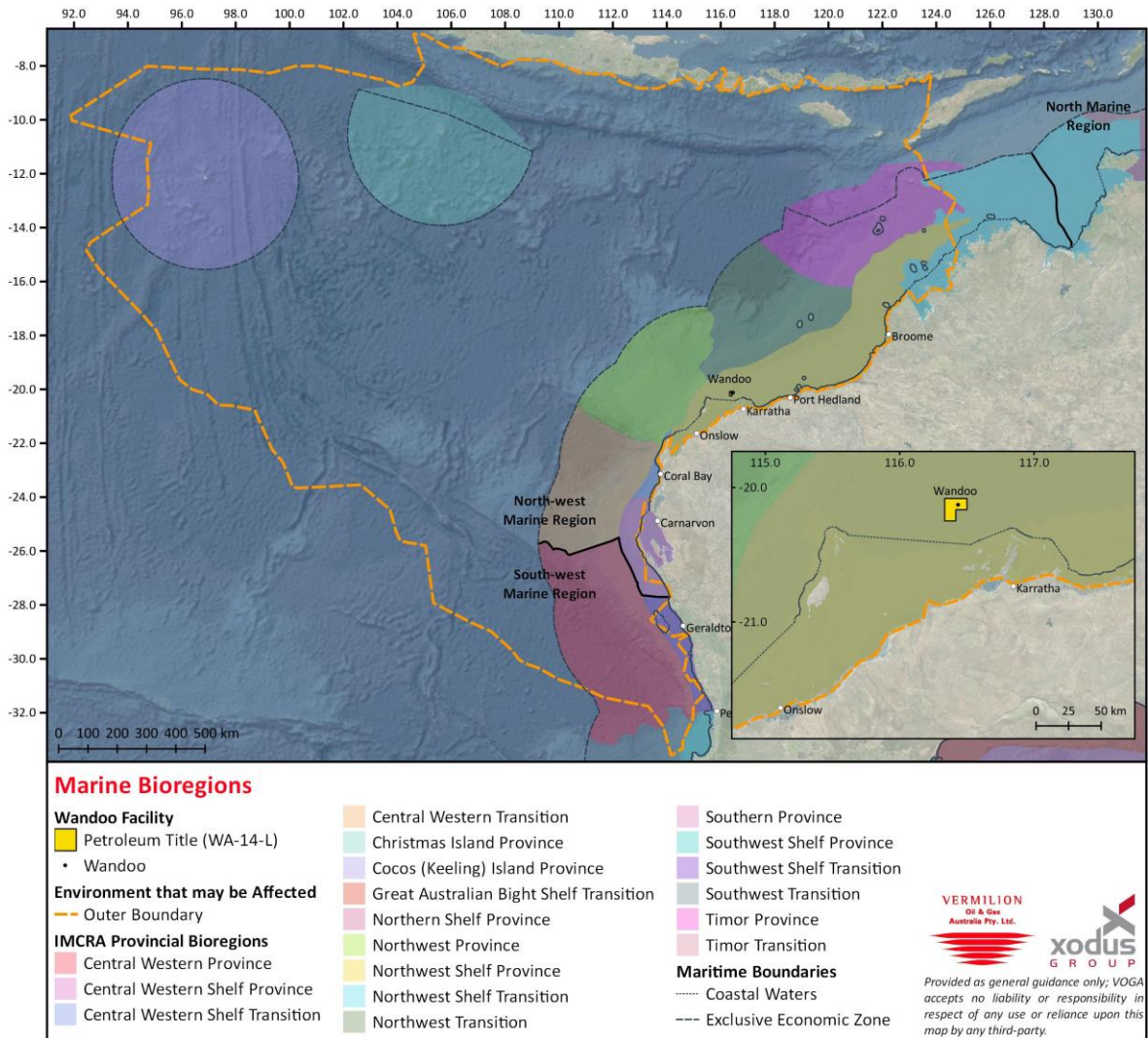

Figure 4-2: Marine Bioregions

4.3.1 North-West Marine Region

The North-west Marine Region lies within Commonwealth waters from the border of WA and the Northern territory (NT) to Kalbarri, covering ~1.07 million km² of tropical and sub-tropical waters.

Over 60% of the seafloor within the region is continental slope, of which extensive terraces and plateaux make up a large proportion. A majority of shallow waters are focused adjacent to the Pilbara and Kimberly regions (~30% of the total region) with the narrowest shelf margin of the region and Australia located at Ningaloo Reef. A majority of the region is relatively shallow with

over 50% having water depths of less than 500m. The sections of the Argo and Cuvier plains which lie within the region make up 10% of the its total area and are the deepest sections of the region reaching depths of almost 6000m.

The region is characterised by shallow-water tropical marine ecosystems. Endemism within the region is not particularly high by Australian standards, however, globally significant populations of internationally threatened species commonly occupy within the region.

4.3.2 South-West Marine Region

The South-west Marine Region lies within Commonwealth waters and extends from the eastern end of Kangaroo island, off the coast of South Australia, to Shark Bay in Western Australia, covering ~1.3 million km². The region is characterised by temperate waters off the south west of WA and subtropical waters along the southern coast, with high wave action throughout the region focused on the continental slope. By global standards, the South-west Marine Region is high in biodiversity with many species' endemic to the region.

Dominant physical features of the region include a narrow continental shelf on the south-west coast transitioning into a wider continental shelf along the Great Australian Bight (GAB). Water depths vary throughout the region with islands and steep and muddy continental slopes, including canyons, being a common feature. Deeper waters of the region are poorly understood and can extend to greater than 4000 m.

4.3.3 Outside of Australia's Exclusive Economic Zone

The Exclusive Economic Zone (EEZ) located off the Western Australian coastline extends from the territorial sea limit across the mainland of Australia's Indian Ocean Territories, to 200 nautical miles offshore. The Australian EEZ shares boundaries with:

- International waters, which lie to the west and south of the WA section of EEZ. The United Nations Law of the Sea Convention (UNCLOS) manage international waters and is administered by the International Maritime Organisation (IMO);
- The Joint Petroleum Development Area (JPDA) in the Timor Sea which lies along the northern edge of the EEZ. The national Petroleum Authority of Timor-Leste regulates the JPDA on behalf of the Australian and Timor-Leste government; and
- Indonesia to the north-west, of which the boundary is defined in accordance with the Perth Treaty, negotiated with the Republic of Indonesia.

Indonesia has the second largest coastline in the world (95 181km) and has the largest coral reef area of any country (51 020km²). Central and eastern Indonesia lies within the Coral Triangle which in an area of globally recognised biodiversity. Key threats to Indonesian reefs include direct human impacts such as overfishing and destructive fishing methods, as well as indirect impacts such as pollution and coastal development.

Indonesia has established a large network of marine protected areas (MPA) in order to manage environmental sensitivities within its waters. MPAs relevant to the Wandoo Facility activities are listed in Table 4-3.

Table 4-3: Relevant Indonesian Marine Protected Areas

Name	Protection Category / Listing	Operational Area & Mixing Zone	Hydrocarbon Area	EMBA
KKPD Pantai Penyu Pangumbahan Sukabumi Coastal Park	IUCN VI		X	X
KKPD Kabupaten Pangandaran Coastal Park	IUCN VI			X
KKPN Kabupaten Gunung Kidul Marine Nature Reserve	IUCN IV			X
KKPN Pulau Gili Ayer Marine Recreation Reserve	IUCN VI			X
KKP Nusa Penida Marine Recreation Park	IUCN VI			X
Komodo National Park	IUCN II		X	X
KKPD Kabupaten Flores Timur Marine Nature Reserve	IUCN IV			X
Pulau Lembata District Marine Protected Area	Not Reported			X
Teluk Kupang Nature Recreation Park	IUCN V			X
KKPN Laut Sawa Marine National Park	IUCN II		X	X

X= present within area

4.3.4 Central Western Province

The Central Western Transition Province covers an area of 162,891km² of the continental slope and abyss between Shark Bay and North West Cape. The major geomorphic features of the bioregion are the Wallaby Saddle, Carnarvon Terrace, the Cuvier Abyssal Plain and the Cloates and Cape Range Canyons. Almost half the bioregion has water depths of more than 4000 m, with the maximum water depth in the bioregion recorded at 5330 m, and the proximity of deep ocean areas to the continental slope and shelf may have resulted in distinctive biological communities.

The Leeuwin Current, flowing south along the slope, is the dominant oceanographic feature. Interactions between the Leeuwin Current, Leeuwin Undercurrent and the nearshore Ningaloo Current facilitate vertical mixing of water layers and are believed to be associated with sporadic bursts in productivity (particularly during summer). The level of endemism within demersal fish communities on the slope is less than in the bioregions further north. This bioregion is also within the biogeographic transition between tropical and temperate marine species. The major industries in the bioregion are commercial fishing and petroleum.

4.3.5 Central Western Shelf Province

The Central Western Shelf Province is located between Kalbarri and Coral Bay lying entirely on the continental shelf, covering an area of 50,516km². Water levels in the region range from 0 – 100 m with the benthic environment being predominantly flat, comprising mainly sand with some mud and gravel. Width of the region varies along its length from less than 20km from the shoreline to around 125km in the vicinity of Shark Bay.

The major geomorphic feature of the region is Dirk Hartog Shelf. Other topographic features include a small area of reef and tidal sand banks near the entrance of shark bay and an area of banks and shoals offshore Kalbarri.

Major currents in the region include the Leeuwin Current, Ningaloo Current and the Capes Current with the circulation of the inner bay environment of Shark Bay being restricted by a complex network of sills and channels. This, along with limited fresh water flow and high evaporation rates leads to a hypersaline environment. Due to the shallowness of the region, the Leeuwin current and Shark Bay Outflow are likely to dominate the water column.

This bioregion also lies within the biogeographic transition between tropical and temperate marine species. Biological communities within Shark Bay have been well documented and the bay has been declared a World Heritage Area. It has a diversity of habitat areas including rocky shorelines, sandy plains and seagrass, in both high and low energy zones. The level of endemism within demersal fish communities on the slope is less than that in bioregions further north. Major industries in the bioregion include commercial fishing.

4.3.6 Central Western Shelf Transition

Of all the provincial bioregions, the Central Western Shelf Transition is the smallest, covering an area of 9698km², located entirely on the continental shelf between the North West Cape and Coral Bay. The maximum water depth in the region is 100 m.

This bioregion is strongly influenced by the Leeuwin Current and Leeuwin Undercurrent interacting with the northward flowing Ningaloo Current. It lies within a significant biogeographic transition between tropical and temperate species. The bioregion is largely covered by the Ningaloo Marine Park and Ningaloo Reef. Ningaloo Reef is an area of high biodiversity with over 200 species of coral and more than 460 species of reef fish. Other fauna which may occupy the reef environments within the region include marine turtles, dugongs and dolphins with the potential for whale sharks and manta rays to occupy outer reef areas. Commercial fishing and petroleum are important industries in some parts of the bioregion.

4.3.7 Central Western Transition

The Central Western Transition Province is located between Shark Bay and North West Cape covering 162,891km² of continental slope and abyss. Almost half of the region has water depths of more than 4000 m, with maximum recorded water depths within the region of 5330 m. As a result of the proximity of deep ocean areas to the continental slope and shelf, distinctive biological communities may have developed. The major geomorphic features of the bioregion are Carnarvon Terrace, Wallaby Saddle, the Cuvier Abyssal Plain and the Cloates and Cape Range Canyons.

The Leeuwin Current, flowing south along the slope, is the dominant oceanographic feature in the region. Interactions between the Leeuwin Current, Leeuwin Undercurrent and the nearshore Ningaloo Current facilitate vertical mixing of water layers and are thought to be linked with bursts in productivity (particularly during summer). This bioregion also lies within the biogeographic transition between tropical and temperate marine species. The level of endemism within demersal fish communities on the slope is less than that in bioregions further north. Major industries in the bioregion are commercial fishing and petroleum.

4.3.8 Christmas Island Province

Christmas Island is an external territory located in the Indian ocean. The island has an 80km coastline and occupies an area of 137.4km² of which 135km² is a National Park. The island has a tropical climate, commonly experiencing humidity between 80 and 90%. Seasonal wet season is from November to April with an average annual precipitation of 2000 mm.

Of the 80km coastline, a large majority of the is cliff face of up to 20 m high. The island is surrounded by coral reef with the continental shelf extending up to 200 m from the shore and then plummeting to depths of ~5000 m.

Due to the islands close proximity to South-East Asia and the equator, Christmas Island has a highly diverse range of flora and fauna. There are a recorded 411 plant species of which 18 are endemic to the island. Commonly known fauna of the island includes land crabs and a range of seabirds. Eight species or subspecies of seabird nest on the island including the endemic Christmas Island Frigatebird (listed as endangered) which has three well defines nesting areas.

4.3.9 Cocos (Keeling) Islands Province

Cocos (Keeling) Island is an external territory located in the Indian Ocean. The Islands form a horseshoe-shaped atoll made of 27 coral islands with a total land area of ~15.6 km² which surround a lagoon. North Keeling island lies 30km outside the horseshoe atoll and was declared a National Park in 1995.

Coral and sandy beaches lie on the seaward side of the horseshoe atoll whilst mudflats can be found on the lagoon side. The northern atoll consists of north Keeling Island of which the island and the marine park extend 1.5km around the island from the Pulu Keeling National Park. The island is an important example of an atoll in its natural state and supports an internationally significant seabird rookery. The terrestrial and marine environment of the islands supports a wide range of flora and fauna including land crabs, corals, fish, molluscs, crustaceans. Other fauna commonly sighted include turtles, common dolphins, manta rays and reef sharks.

The island has a tropical climate with high humidity. Seasonal wet season is from January to August with an average annual precipitation of 2000 mm.

4.3.10 Northwest Province

The North-west Province lies offshore between Exmouth and Port Headland, entirely on continental slope. The region covers an area of 178,651km² with water depths ranging from 1000 – 300 m.

The dominant geomorphic feature is the Exmouth Plateau. The Montebello Through and Swan Canyon are also important features of the region. The Exmouth Plateau contains the steepest shelf break in the Marine Region along the Cape Range Region near Ningaloo Reef. Dominant surface flow of the region includes circulation and recirculation (via the South Equatorial Current) of the Indonesian Throughflow. As a result of the predominantly southward moving surface waters, waters consolidate along the narrow shelf break adjacent to Cape Range Peninsular to form the Leeuwin Current which is a significant feature for the bioregion and areas further south.

Canyons in the bioregion are thought to aid in the channelling of water onto the Exmouth Plateau and certainly into the shelf along Ningaloo Reef, which aids in enhancing localised biological production. The North-west Province represents the beginning of a transition between tropical

and temperate marine species with high endemism in demersal fish communities on the slope evident in this bioregion. Commercial fishing and petroleum are important industries in some parts of the bioregion.

4.3.11 Northwest Shelf Province

The North-west Shelf Province lies predominantly on the continental slope, extending from the North-west Cape to Cape Bougainville, covering an area of 238,759 km². Width of the bioregion varies along its length from ~ 50 km at the Exmouth Gulf to more than 250 km off Cape Leveque. About half the bioregion has water depths between 50 and 100 m, with maximum depths reaching 200 m.

The bioregion is a dynamic oceanographic environment and is influenced by cyclonic storms, strong and internal tides and long period swell. Its waters derive from the Indonesian Throughflow and are warm, oligotrophic and circulate throughout the bioregion via branches of the South Equatorial and Eastern Gyral Currents.

Fish communities in the bioregion are diverse comprising of both benthic and pelagic fish. Humpback Whales migrate through the area with the Exmouth Gulf considered an important resting area, particularly for mothers and calves on their southern migration. Several important breeding sites for seabirds are located within the region (outside Commonwealth Waters), including Eighty Mile Beach and the Montebello, Barrow and Lacepede islands.

Industries that utilise the resources found in bioregion include the petroleum industry, commercial fishers and shipping, with nationally significant ports of Dampier and Port Headland present.

4.3.12 Northwest Shelf Transition

The Northwest Shelf Transition is divided between the North and North-west Marine Regions and extends from Cape Leveque to the eastern end of Melville Island (in the North marine Region), occupying a total area of 305,463 km² of which 44.7% lies within the North-west marine region.

A majority of the region is located on the continental shelf with a small area extending on to the continental slope. Consequently, the regions water depths are relatively shallow, ranging from 0 – 330 m with most of the region being between 10 and 100 m deep. Topographic features of the region are divers and include reefs, plateaus, submerged terraces, sand banks, pinnacles and canyons.

Due to the generally shallow nature of the region, the Indonesian Throughflow is the dominant oceanographic feature and dominates a majority of the water column. The strength of the throughflow is dependent on seasonal pressures and is heavily influenced by the North-west Monsoon (December to March) which results in a stronger throughflow during winter months. Tides in the region vary greatly and result in increased coastal turbidity levels along with hurricane events.

Biological communities of the region are typical to that of Indo-west Pacific tropical flora and fauna. Marine environments include a range of soft and hard bottom habitats and support a range of filter feeding organisms, coral, crustaceans, sea snakes, turtles, rays, sawfish, fish and sharks. Dugongs are also known to occupy shallower seagrass communities. A number of sites along the Kimberly coastline adjacent to the region are important to seabirds and cetaceans,

including the Indo-pacific humpback dolphin and Australian snubfin dolphin which may be endemic to Australian waters.

4.3.13 Northwest Transition

The North-west Shelf Province covers an area of 184,424km² and predominantly occurs on the continental slope (52%), with smaller areas in the north-west located on the Argo Abyssal Plain and continental rise (DEWHA, 2008). Water depths vary, generally ranging from 200 m depths at the shelf break to more than 1000 m over the continental slope with a maximum depth of 5980 m.

The seafloor topography of the bioregion is complex with a range of features including carbonate banks, submerged terraces, pinnacles, sand banks and reefs. The pinnacles and carbonate banks of the Joseph Bonaparte Gulf are distinctly different in morphology and character to other parts of the Region and are believed to support a high diversity of marine species.

Biological communities of the region are typical to that of Indo-west Pacific tropical flora and fauna. Marine environments include a range of soft bottom and hard substrate habitats. The Western Australian population of humpback whales mate and give birth in the inshore waters off the Kimberley. In addition, the Northwest Shelf Transition is important for commercial fisheries, defence, and the petroleum industry.

4.3.14 Southwest Shelf Transition

The Southwest Shelf Transition covers the area of continental shelf from Perth to Kalbarri. ridges and inshore lagoons characterise the seafloor of the continental shelf of this area. The bioregion has high biodiversity and contains a large number of species that are found nowhere else in the world.

The Houtman Abrolhos Islands off Geraldton are renowned for their high species diversity, coral reefs and a unique mix of temperate and tropical species. These islands are also an important breeding site for seabirds and are the northernmost breeding site for the Australian sea lion. The Houtman Abrolhos Islands, inshore lagoons and other islands further south, such as the Beagle Islands, provide important areas of shelter for shallow water communities in a bioregion that is otherwise exposed to ocean swells. The inshore lagoons are known for the enhanced benthic productivity of their macro-algae and seagrasses and for supporting breeding and nursery aggregations of numerous marine species.

The western rock lobster is an iconic species of the bioregion with an important trophic role for a range of inshore species that prey on juvenile lobsters.

4.3.15 Southwest Transition

The Southwest Transition is dominated by the Naturaliste Plateau, a large extension of the continental plate, which adjoins the continental slope through the Naturaliste Trough. Little biological sampling has been conducted here due to its remoteness and rough waters, but based on its characteristics and data from elsewhere in the world, scientists believe that the Plateau hosts rich and diverse biological communities.

4.3.16 Timor Province

The Timor Province lies between Broome and Cape Bougainville, occupying ~15% of the North-west Marine Region and covering predominantly continental slope and abyss. Water depths range from ~200 m from near the shelf break to up to 5920 m over the Argo Abyssal Plain. In addition to the Argo Abyssal Plain, the main geomorphic features within the region are the Ashmore Terrace, Scott Plateau, the Bowers Canyon and part of the Rowley Terrace.

The bioregion is dominated by the warm, oligotrophic waters of the Indonesian Throughflow. This region has a particularly pronounced thermocline in the water column and is associated with the generation of internal tides which is a significant oceanographic feature of this region. The variation in bathymetry together with the variety of geomorphic features in the province results in numerous distinct habitats and biological communities of which many are in close proximity to each other. The islands and reefs that lie within the bioregion are regarded as particular hotspots for biodiversity. Demersal fish communities of the bioregion have high endemism with two distinct communities identified.

4.4 Detailed Receptor Descriptions

4.4.1 Physical environment

4.4.1.1 Ambient water quality

Table 4-1 identifies that ambient water quality may be a relevant receptor to aspects of the activity occurring within the Operational Area, Mixing Zone, Hydrocarbon Area and EMBA during the Petroleum Activity. The description below provides sufficient details to assess all impacts and risks to ambient water quality.

Marine water quality within the EMBA is expected to be representative of the typically pristine and high water quality found in offshore Western Australian waters. Variations to this state (e.g. increased turbidity) may occur in more coastal regions that are subject to large tidal ranges, terrestrial run-off or anthropocentric factors (i.e. ports, industrial discharges, etc.).

Water quality sampling data is available within Pilbara coastal waters, within the EMBA:

- no detectable hydrocarbons, with BTEX, PAH and TPH below the laboratory LOR (Wenziker et al., 2006).
- concentrations of metals were typically below the ANZECC & ARMCANZ (2000) 99% species protection guidelines (Wenziker et al., 2006).
- slightly elevated levels (although still above the 95% species protection levels) of copper and zinc were recorded within the inner harbour at Port Hedland (Wenziker et al., 2006).

4.4.1.2 Ambient sediment quality

Table 4-1 identifies that ambient sediment quality may be a relevant receptor to aspects of the activity occurring within the Operational Area, Mixing Zone, Hydrocarbon Area and EMBA during the Petroleum Activity. The description below provides sufficient details to assess all impacts and risks to ambient sediment quality.

Several surveys have been undertaken within the Operational Area and Mixing Zone. In addition to the Bowman Bishaw Gorham (BBG) (1996) baseline sediment survey, a post-commissioning sediment survey was undertaken by Sinclair Knight Merz (SKM) in 1998. BBG (1996) found the sediments were comprised of a mixture of fine, medium, coarse and very coarse sands. This is consistent with sediments found throughout the NWS Province where sediment is dominated by sand (Baker et al., 2008). Particle size data from the study undertaken by SKM in 1998 indicated that sediments are typically comprised of unconsolidated to coarse sands. This shift towards a coarser grain size is indicative of discharge received from drilling at Wandoo.

Sediment metal, petroleum hydrocarbon and Polycyclic Aromatic Hydrocarbon (PAH) levels were also tested during both studies. Sediment metal levels increased since the baseline survey; however, they were within the trigger values outlined in the ANZECC/ARMCANZ sediment quality guidelines (ANZECC/ARMCANZ, 2000). These metal concentrations reflect background levels of the region (Long et al., 1995). Petroleum hydrocarbons and PAH levels were below detection limits in all samples collected during the surveys.

An additional baseline survey was undertaken in 2015 to assess changes that may have occurred since the original baseline and post-commissioning surveys undertaken in the 1990s (Operational Baseline Survey 2015 Report Ref: 246043-001-REP-NM-001, August 2016).

Hydrocarbons in sediments at all sites were below the limits of reporting or below the available Sediment Quality Guideline for the highest level of protection. Sediment metal/metalloid concentrations at all sites were below their respective trigger values, or where no guidelines exist lower or similar to previous studies with the exception of Barium. This was likely due to the presence of residual drilling muds (containing barium) at the time of the post-commissioning survey.

There has been an overall increase in sediment metal concentrations since the baseline survey 20 years ago (BBG 1996) but there is no trend in direction or distance from the WNB Platform. Furthermore, of the metals that have increased in sediments since the baseline survey, none are currently at concentrations exceeding the recommended guideline for the highest level of species protection.

In 2015, sediment infauna abundance and species richness were significantly higher than during the baseline survey in 1996 and the post-commissioning survey in 1998.

4.4.1.3 Air quality

Table 4-1 identifies that air quality may be a relevant receptor to aspects of the activity occurring within the Operational Area during the Petroleum Activity. The description below provides sufficient details to assess all impacts and risks to air quality.

The majority of the offshore NWS Province region is relatively remote and therefore air quality in the Operational Area is expected to be high. Anthropogenic sources (e.g. vessels, industry developments) would contribute to local variation in air quality. However, results of previous monitoring within the region suggest that the concentration of air quality parameters remains low. For example, measured levels of nitrogen dioxide and ozone during a Pilbara air quality study were below the NEPM standards (DoE 2004).

4.4.1.4 Climate

Table 4-1 identifies that climate may be a relevant receptor to aspects of the activity occurring within the Operational Area during the Petroleum Activity. The description below provides sufficient details to assess all impacts and risks to climate.

Climate within the Operational Area is tropical, exhibiting a hot 'summer' season from October to April and a milder 'winter' season between May and September. Winds vary seasonally, with a tendency for westerly winds in summer and southerly winds in winter (Pearce et al., 2003). There are often distinct 'transition' periods between the summer and winter regimes, which are characterised by calmer periods. Rainfall is low and unpredictable, with most rainfall occurring between January and May, often associated with the passage of tropical cyclones (Pearce et al., 2003).

4.4.1.5 Ambient noise

Table 4-1 identifies that ambient noise may be a relevant receptor to aspects of the activity occurring within the Operational Area during the Petroleum Activity. The description below provides sufficient details to assess all impacts and risks to ambient noise.

The Operational Area is relatively remote and therefore ambient noise levels are expected to be low. Ambient noise within the NWS Province region is expected to be dominated by natural physical (e.g. wind, waves, rain) and biological (e.g. echo-location and communication noises generated by cetaceans and fish) sources. Anthropogenic noise sources that are also likely to be experienced in the area include low-frequency noise from vessels.

4.4.1.6 Ambient light

Table 4-1 identifies that ambient light be a relevant receptor to aspects of the activity occurring within the Operational Area during the Petroleum Activity. The description below provides sufficient details to assess all impacts and risks to ambient light.

The Operational Area is relatively remote and therefore ambient light levels are expected to be low. Ambient light within the NWS Province region is expected to predominantly be from solar/lunar luminance. However, artificial light sources associated with anthropogenic activities also exist, including both permanent (e.g. onshore/offshore developments) and temporary (e.g. vessels) light sources.

4.4.2 Key marine habitats

Table 4-1 identifies that key marine habitats may be a relevant receptor to aspects of the activity occurring within the Operational Area, Mixing Zone, Hydrocarbon Area and EMBA during the Petroleum Activity. The description below provides sufficient details to assess all impacts and risks to key marine habitats.

4.4.2.1 Subtidal soft sediment and benthic fauna

Unconsolidated sediments support diverse benthic fauna living both in the sediments (infauna) and on the sediment surface (epifauna). Infauna species consist predominantly of mobile burrowing species including molluscs, crustaceans (crabs, shrimps and smaller related species), polychaetes, sipunculid and platyhelminth worms, asteroids (sea stars), echinoids (sea urchins)

and other small animals. Epifauna species include small crustaceans and molluscs, echinoderms and larger sessile organisms such as sponges, corals, sea whips and sea squirt (DEC, 2006).

Remote Operated Vehicle (ROV) surveys on the NWS, at similar water depths to those in the Operational Area and Mixing Zone, have indicated a sea floor is comprised of fine silt/sand substrates (RPS, 2012 unpublished data). The sediments were variously bioturbated, however benthic communities were generally sparse with low densities of organisms (e.g. crustaceans, molluscs, and polychaetes).

Soft sediment habitats that support infauna are widespread in deeper offshore areas and in more protected environments throughout the region (CALM and MPRA, 2005; DEC, 2006). The sediments range from clays to silts and fine sands. The depths of the Argo Abyssal Plain support sparsely distributed sessile organisms such as filter-feeding and deposit-feeding species (DEWHA, 2008). The spatial and temporal distribution and density of infauna depends not only on sediment composition but also on factors such as season, water depth, water temperature and wave-induced currents (Ward and Rainer, 1988; Rainer, 1991; Kinhill, 1997). Communities in shallower areas (less than 30m deep) are likely to be dominated by sessile filter-feeding species such as sponges, sea pens and ascidians. Sediments in deeper water are typically finer (muddier) and the benthic community is dominated by benthic scavengers and deposit feeders including polychaete worms, crustaceans, molluscs and echinoderms (DEWHA, 2008).

The sea floor of the deeper waters of the NWS is primarily a soft sediment habitat that can support scavengers, benthic filter feeders and epifauna communities (Brewer *et al.*, 2007). Any areas of exposed hard substrate are likely to be colonised by deep water filter-feeding organisms, such as hydroids and sponges.

4.4.2.2 Corals

Corals are generally divided into two broad groups: the zooxanthellate ('reef-building', 'hermatypic' or 'hard') corals, which contain symbiotic microalgae (zooxanthellae) that enhance growth and allow the coral to secrete large amounts of calcium carbonate; and the azooxanthellate ('ahermatypic' or 'soft') corals, which are generally smaller and often solitary (Tzioumis and Keable 2007). Hard corals are generally found in shallower (<50 m) waters while the soft corals are found at most depths, particularly those below 50 m (Tzioumis and Keable 2007).

Hard corals are widespread within the EMBA, with significant coral reefs occurring at a number of sites including within the Ningaloo Marine Park near Exmouth, the Montebello / Barrow / Lowendal islands, Muiron island, the Dampier Archipelago, Glomar Shoals, Rankin Bank, Mermaid Reef and the Rowley Shoals (Figure 4-3). In the NWS region coral reefs in clearer, offshore waters typically have higher coral density and diversity than reefs associated with turbid near-shore waters (Woodside, 2006).

In addition to the larger coral reefs that have regional significance, smaller reefs and individual coral colonies are found throughout areas where water quality and benthic substrate are conducive to coral survival. Intertidal hard corals also occur within the EMBA, typically as individual colonies on rocky shores. These intertidal corals do not form a large habitat class within the region, with beaches/mudflats and mangroves the most common shoreline habitat.

There is a distinct zonation of coral types, with reefs to the north of Ashmore Reef composed mostly of coralline (soft) algae, whereas Ashmore Reef and other reefs to the south are mostly composed of scleractinian corals (i.e. hard corals) (Baker *et al.*, 2008). The transition to hard corals

from Ashmore Reef south is caused by the upwelling of cooler, nutrient-rich water from the Indian Ocean along the continental shelf break. This provides preferential conditions for the development of hard corals (DEWHA, 2008). The warmer water temperatures north of Ashmore Reef restrict the formation of hard corals, and the coral types found off southern Indonesia are compositionally different.

Christmas and the Cocos (Keeling) Islands also support diverse coral reefs. Christmas Island has 88 both hard and soft corals (DoEE, 2014b), while the Cocos (Keeling) Islands has recorded 99 species of reef corals. Of these, all but 12 are known from WA. Nine species are not recorded elsewhere in the eastern Indian Ocean and two (one being taxonomically doubtful) are possibly endemic (DoEE, 2014a).

In Indonesia, the warm waters support an abundance of coral, though extensive reef flat and reef crest structures have not developed on the southern side of Java due to the extreme exposure and high energy environment (Tun et al., 2004). Fringing reefs are well developed adjacent to the Meru Betiri National Park, and around the Blambangan Peninsula protected by the Alas Purwo National Park. Further east, the island of Nusa Tenggara contains conditions which are ideal for reef development, and there are widespread fringing reefs along the shores of the island (Tun et al., 2004). The south coast has a narrower reef flat which is fully exposed to Indian Ocean swell and may be further affected by cool water upwellings, and a number of deep water species are found which may prefer cooler waters (Tun et al., 2004).

Corals and reefs are also found scattered along the southern marine waters off the islands Bali and, and continuous reefs are found along the southern and eastern fringes of West Nusa Tenggara (UNEP/IUCN, 1988). Fringing reefs are also well established along the western and southern waters of Sumbawa Island, while Sumba Island has coral reefs off the island's north-western tip, south and eastern extent. Komodo National Park World Heritage Area (WHA) protects coral reefs that surround the group of protected and sheltered islands. The Islands of Sawu, Roti and Timor also have well established and extensive reef systems bordering their shorelines (UNEP/IUCN, 1988).

Significant coral spawning occurs in autumn for a number of species, although some taxa such as *Porites* and *Acropora* spp. may spawn in spring and summer (Baird et al., 2011; Rosser and Gilmour, 2008). Spawning events have been observed throughout the Dampier Archipelago in March and April (Stoddart and Gilmour, 2005) and along the Ningaloo Coast during March (Simpson et al., 1993). A study at Scott Reef found two short and distinct periods of mass spawning during spring and autumn, in contrast to the single mass spawning described on most other reefs around Australia (Gilmour et al., 2007).

No coral reef communities are found in the Operational Area or Mixing Zone. The nearest area of significant corals reef to the Operational Area or Mixing Zone are the Glomar Shoals (approximately 40 km northeast), Dampier Archipelago (approximately 40 km southeast), Barrow/Montebello Islands (approximately 95 km southwest) and Ningaloo Reef (approximately 280 km southwest). The Ningaloo Reef is unique in that it is a mainland fringing coral reef, the largest of its kind in Australia (CALM and MPRA, 2005). The Ningaloo Reef extends over 260km and is the only large reef in the world found so close to the western coast of a continental land mass (within 100 m at closest point). The Reef includes intertidal and deeper sub-tidal corals, with over 300 species representing 54 genera recorded (UNESCO, 2011).

4.4.2.3 Seagrasses

Seagrass are marine flowering plants, with about 30 species found in Australian waters (Huisman 2000). Seagrass generally grows in soft sediments within intertidal and shallow subtidal waters where there is sufficient light and are common in sheltered coastal areas such as bays, lees of islands and fringing coastal reefs (McClatchie *et al.*, 2006; McLeay *et al.*, 2003). Seagrasses are important primary producers in tropical in-shore waters as they provide energy and nutrients for detrital grazing food webs. Seagrass meadows are important in stabilising seabed sediments, and providing nursery grounds for fish and crustaceans, and a protective habitat for the juvenile fish and invertebrates species (Huisman 2000; Kirkman 1997). Seagrasses also provide important habitat for fish and dugongs within the Northwest Shelf Province (DEWHA 2008).

Seagrasses are widespread throughout shallower areas of the EMBA and Hydrocarbon Area. No seagrasses are found within the Operational Area or Mixing Zone.

Seagrass species within the EMBA exhibit seasonal trends in abundance and distribution (Orth *et al.*, 2006). Natural disturbance events such as cyclones and dugong grazing can also affect local seagrass distribution and abundance.

Ideal conditions for seagrasses include clear waters, low nutrients, protection from heavy seas and swells, and sandy substrate. Many seagrass species are perennial (grow all year round) and cover extensive areas, such as those of Shark Bay and Exmouth Gulf. Seagrasses can also be found adjacent to offshore islands, including Dampier Archipelago and the Montebello and Barrow islands (CALM and MPRA, 2005; DEC, 2006), as well as the islands of Indonesia. Protected seagrass areas of southern Indonesia are in the marine waters of the Komodo National Park WHA, located within the Lesser Sunda Islands (Hoyt, 2012). Large areas of seagrass are also found in the waters surrounding Ashmore Reef, which are important feeding grounds for a small but genetically distinct dugong population (DEWHA, 2008).

Seagrass meadows are mostly found in the sheltered bays along the southern mainland coast of the Kimberley region, as well as along the coast between Shark Bay and Augusta. Montebello and Barrow Islands contain sparse seagrass habitat (McMahon *et al.*, 2017), however the closest known key areas of seagrass habitat to the Wandoo Facility is the Exmouth Gulf and Ningaloo Reef area.

4.4.2.4 Macroalgae

Macroalgae are widely distributed throughout shallower areas of the region, particularly where hard substrates occur; although species such *Caulerpa*, *Halimeda*, *Udotea* and *Penicillus* can anchor in soft sediments or attach to shell fragments or rubble. Subtidal macroalgae often occur with coral reefs, colonising dead coral and coral rubble for attachment. Intertidal macroalgae may also occur throughout the region, as there is widespread intertidal hard substrate and intertidal rock platforms suitable for macroalgal growth. Macroalgae are important primary producers and support diverse and abundant fauna of small invertebrates that are the principal food source for many in-shore fish species.

A large number of tropical macroalgal species have been recorded from the region, with over 200 species documented in the Pilbara alone (Huisman, 2004; Huisman and Borowitzka, 2003). Macroalgal habitat within the region may occur in subtidal or intertidal areas of hard substrate where sufficient light is available for photosynthesis. Such areas are likely to include shallow (<25 m) subtidal reefs and rocky intertidal shores and be widespread throughout the region.

Due to the widespread nature of macroalgal habitat within the region, there are no specifically identified areas of significant environmental value.

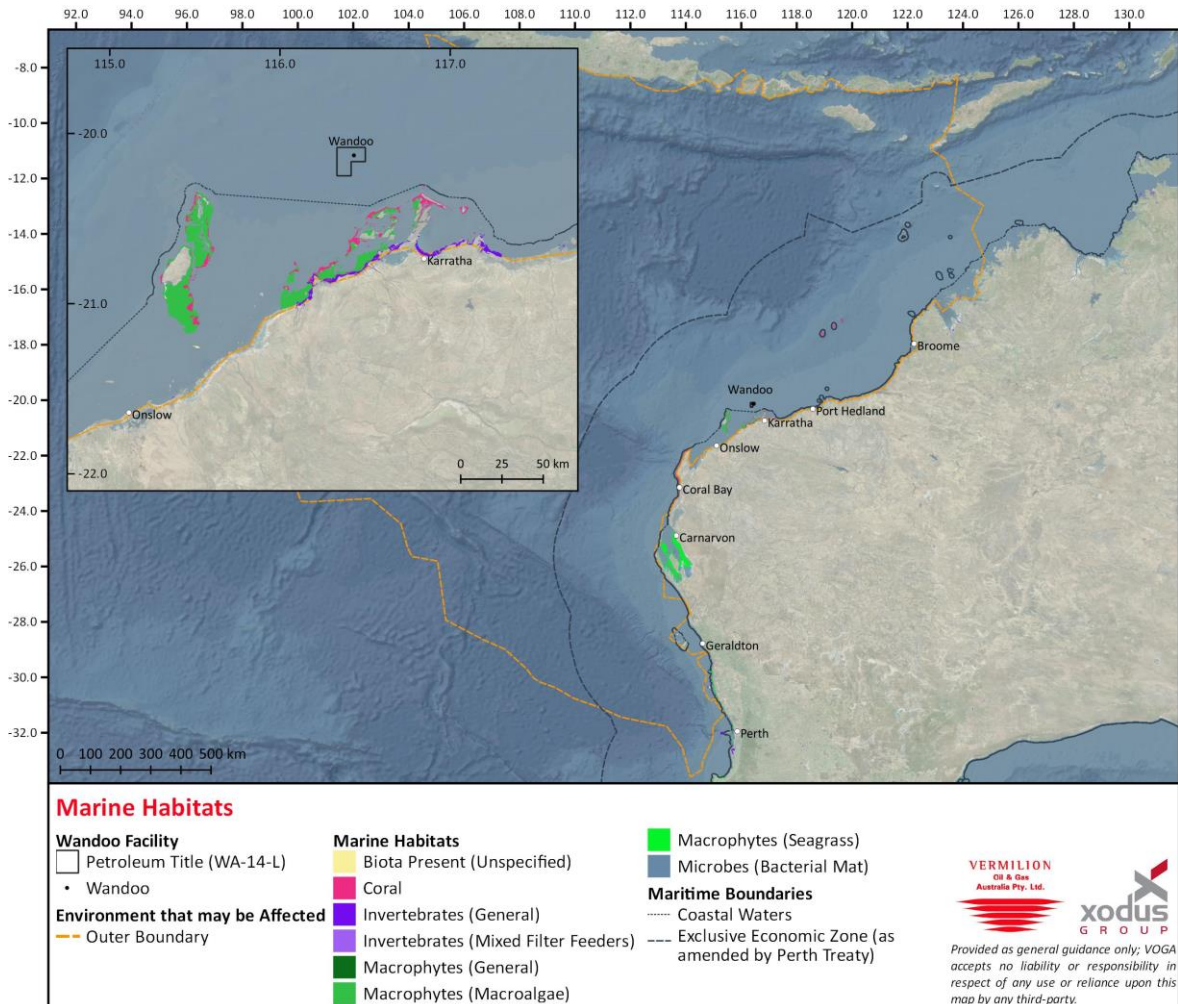

Figure 4-3: Known mapped extents of Key Marine Habitats

4.4.3 Key coastal communities

Table 4-1 identifies that key coastal communities may be a relevant receptor to aspects of the activity occurring within the Operational Area, Mixing Zone, Hydrocarbon Area and EMBA during the Petroleum Activity. The description below provides sufficient details to assess all impacts and risks to key coastal communities.

4.4.3.1 Mangroves

Mangroves are recognised as significant because they are productive coastal forest systems, providing habitat and shelter for infauna, epifauna, gastropods, crustaceans, fish and other marine species. Mangroves are important nursery areas for fish, lobster and prawn species, some of which are targeted by recreational and commercial fishers (Nagelkerken et al., 2008; DEC, 2007a). Mangroves may also provide shelter for other species such as juvenile turtles (DEC, 2007a). Ospreys (*Pandion haliaetus*) and white-bellied sea eagles (*Haliaeetus leucogaster*) roost in mangroves, while brahminy kites (*Haliaeetus indus*) and a range of smaller birds nest in them (DEC,

2007a). Mangroves are also recognised for their capacity to protect coastal areas from erosion due to storms and storm surge.

Mangroves can occur on a wide range of geomorphic types (Semeniuk, 1986) and are one of the dominant intertidal and coastal habitat classes within the EMBA, with extensive belts of mangroves between Coral Bay and Eighty Mile Beach (Carr and Livesey, 1996) (Figure 4-4). They also occur on the offshore islands in the region, including Barrow Island, the Montebello Islands and the Dampier Archipelago.

Mangrove communities in the Pilbara region are classified as ‘tropical arid’ mangroves and represent Australia’s only ‘tropical-arid’ mangroves (Pedretti and Paling, 2000). WA does not support any unusual, endemic or restricted mangrove species. All mangrove species within WA are common and widespread elsewhere, either in northern Australia or in the Indo-Pacific region near northern Australia.

All of the 18 species of mangroves found in WA are found in the North West, with the highest mangrove diversity occurring in the Kimberley and Pilbara region (Pedretti and Paling, 2000), with diversity tending to decrease at higher latitudes. Indonesia contains a great abundance of mangroves, with more species being found here than the Australian continent, supported by the warmer, tropical climate (Whitten et al., 1996). There are 31 species of mangrove that have been identified in Java and Bali.

No mangrove communities are found within the Operational Area or Mixing Zone. The closest regionally significant mangroves to the Operational Area and Mixing Zone are those occurring within the Dampier Archipelago. Other regionally significant areas of mangrove habitat occurring within the EMBA and Hydrocarbon Area include the Montebello Islands, Ningaloo Coast, and scattered areas along the coast between Onslow and just north of Port Hedland and Hosnies Spring, Christmas Island (EPA, 2001).

4.4.3.2 *Saltmarsh*

Saltmarshes are terrestrial halophytic (salt-adapted) ecosystems that mostly occur in the upper-intertidal zone. They are typically dominated by dense stands of halophytic plants such as herbs, grasses and low shrubs. The diversity of saltmarsh plant species increases with increasing latitude (in contrast to mangroves). The vegetation in these environments is essential to the stability of the saltmarsh, as they trap and bind sediments. The sediments are generally sandy silts and clays, and can often have high organic material content. Saltmarshes provide a habitat for a wide range of both marine and terrestrial fauna, including infauna and epifaunal invertebrates, fish and birds.

Saltmarsh habitat is common within tidal flats or wetland habitats along the Pilbara coast (Figure 4-4).

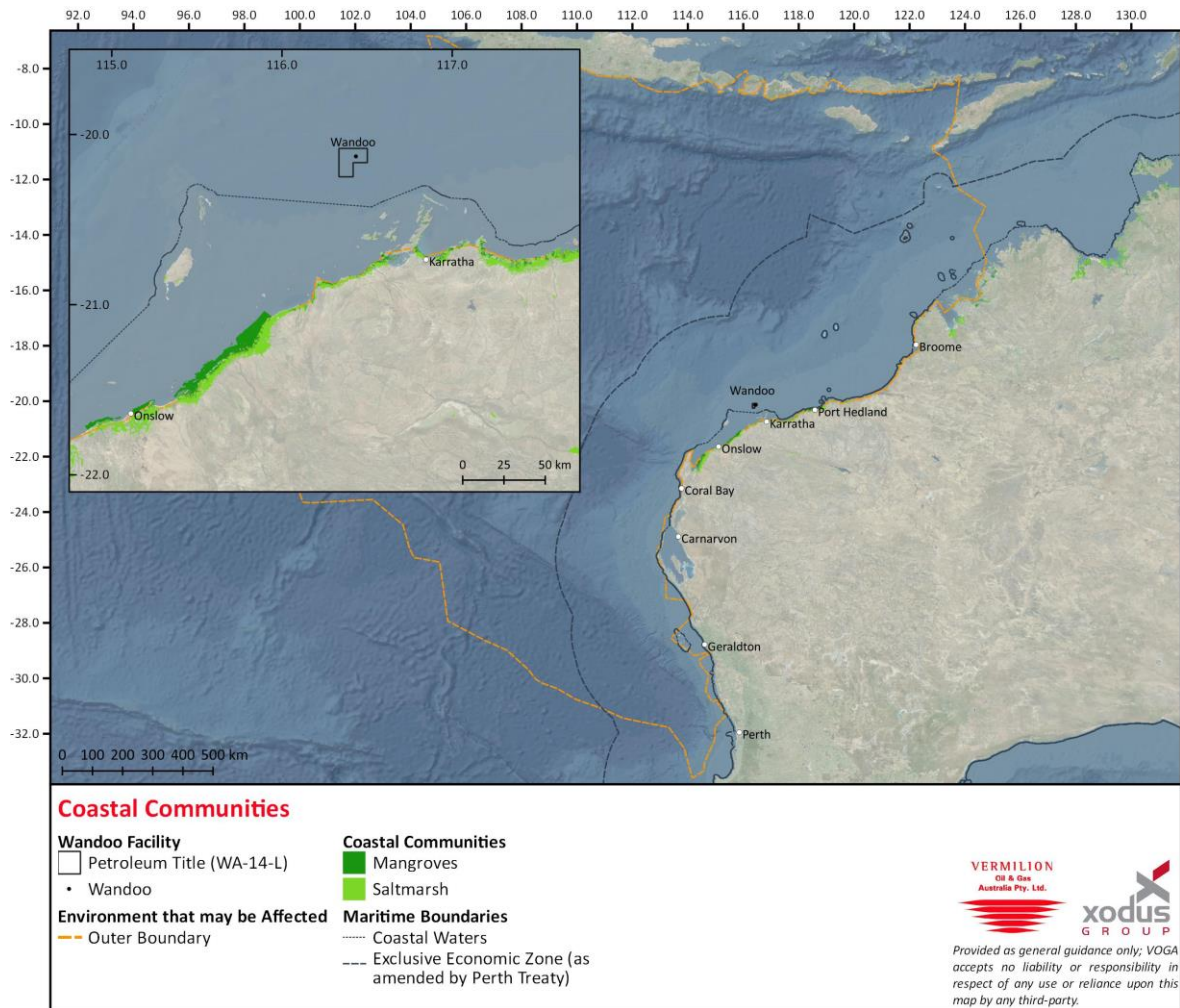

Figure 4-4: Known mapped extents of Mangrove and Saltmarsh Communities

4.4.3.3 Intertidal beaches/mudflats

Intertidal beaches and mudflats are widespread throughout the EMBA and Hydrocarbon Area and occur on both mainland and island shores. Intertidal beaches and mudflats in the region host a range of infauna, including molluscs and polychaetes that are likely to be an important food source for wading birds.

Three intertidal beach/mudflat areas of international conservation significance occur within the EMBA and Hydrocarbon Area: Bandicoot Bay, Eighty Mile Beach and Roebuck Bay. These habitats are recognised as an important resource for a diverse range of migratory bird species, the majority of which feed in the area after migrating from the northern hemisphere. Bandicoot Bay is a Conservation Reserve within the Montebello/Barrow Islands Marine Management Area and Eighty Mile Beach and Roebuck Bay are listed under the Ramsar Convention (for wetlands; see Section 4.6.7) and are afforded specific protection under the EPBC Act.

No Intertidal beaches/mudflats are found within the Operational Area or Mixing Zone.

4.4.3.4 *Rocky shorelines/intertidal reef platforms*

Rocky shorelines and intertidal reef platforms are widespread throughout the EMBA and Hydrocarbon Area, occurring on both mainland and island shores (Figure 4-5). No rocky shorelines/intertidal reef platforms are found within the Operational Area or Mixing Zone.

Rocky shores can include pebble/cobble, boulders, rocky limestone cliffs and horizontal rock platforms. Intertidal reef platforms are located in the intertidal zone and consist of hard bedrock. Examples include areas with or without a sediment veneer of varying thickness. Rocky shoreline formations offer habitat to a range of intertidal species including invertebrates and shorebirds. Rocky shorelines are found across the region and are often indicative of high-energy areas (wave action) where sediment deposition is limited or restricted. They are formed from limestone pavement extending out from the beach into subtidal zones, e.g. along the Ningaloo Coast and North West Cape. Higher relief platforms (>0.5 m off the high water mark) are also present at several headlands along the North West Cape (DEC, 2006).

Intertidal habitats support a diverse assemblage of vertebrates and invertebrates, particularly in vegetated areas. Coral reef communities located in the intertidal zone include the reef crest, shallow reef fronts, reef flat and shallow back reef zones, generally with a mixture of live coral and macro-algal coverage. Subtidal communities include the upper seaward reef slope, sheltered back reef, deep lagoonal reef and bommie clusters with a high percentage of hard corals, macro-algae and coralline algae (Bancroft, 2003). Invertebrates such as polychaete worms, crustaceans and echinoderms are also known to be present.

4.4.3.5 *Sandy beaches*

Sandy beaches are those areas within the intertidal zone where unconsolidated sediment has been deposited by wave and tidal action. Sandy beaches can vary from low to high energy zones which will influence the profile of each beach through varying rates of erosion and accretion. Sandy beaches are found throughout the EMBA and shoreline Hydrocarbon Area (Figure 4-5). They are generally interspersed among areas of hard substrate (e.g. sandstone) that form intertidal platforms and rocky outcrops.

Sandy beaches can also provide a turtle nesting habitat, particularly at the Barrow/Montebello/Lowendal islands and Ningaloo Coast. Further information on turtle nesting areas is provided in Section 4.4.4.6.

Sandy beaches provide habitat for a variety of burrowing invertebrates and subsequently provide foraging areas for seabirds. Crested terns are known to nest on sandy beaches. Further detail on breeding and nesting sites for seabirds is provided in Section 4.4.4.3.

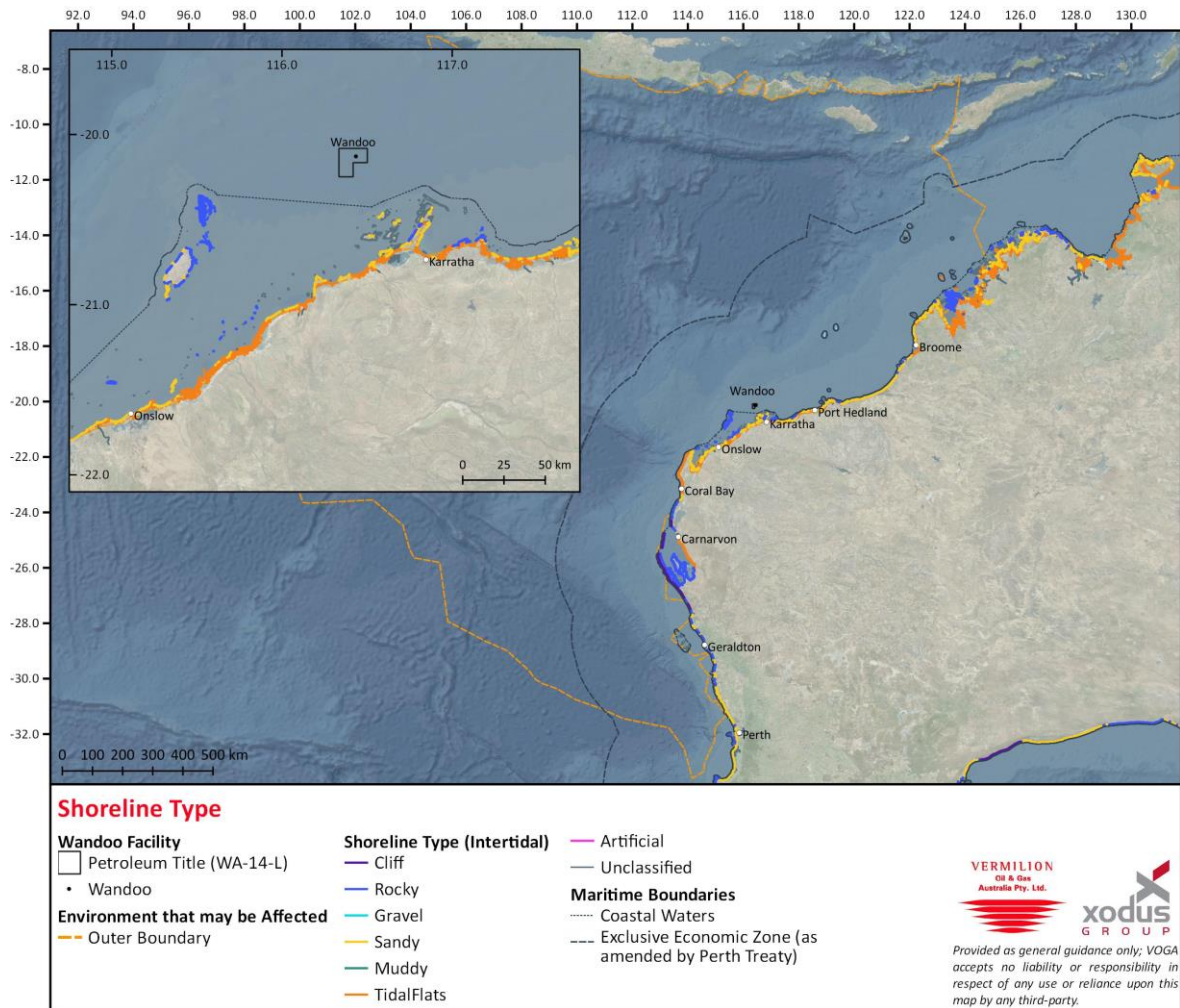

Figure 4-5: Dominant Shoreline Types

4.4.4 Key marine fauna

Table 4-1 identifies that key marine fauna may be a relevant receptor to aspects of the activity occurring within the Operational Area, Mixing Zone, Hydrocarbon Area and EMBA during the Petroleum Activity. The description below provides sufficient details to assess all impacts and risks to key marine fauna.

4.4.4.1 Plankton

Table 4-1 identifies that plankton may be a relevant receptor to aspects of the activity occurring within the EMBA, Hydrocarbon Area, Mixing Zone and Operational Area during the Petroleum Activity. The description below provides sufficient details to assess all impacts and risks to plankton.

Plankton species, including both phytoplankton and zooplankton, are a key component in oceanic food chains. Phytoplankton are autotrophic planktonic organisms living within the photic zone; and are the start of the food chain in the ocean (McClatchie *et al.*, 2006). Phytoplankton communities are largely comprised of protists, including green algae, diatoms, and dinoflagellates (McClatchie *et al.*, 2006). There are three size classes of phytoplankton: microplankton (20-200 µm), nanoplankton (2-20 µm) and picoplankton (0.2-2 µm). Diatoms and dinoflagellates are the

most abundant of the micro and nanoplankton size classes and are generally responsible for the majority of oceanic primary production (McClatchie *et al.*, 2006). Phytoplankton are dependent on oceanographic processes (e.g. currents and vertical mixing), that supply nutrients needed for photosynthesis. Thus, phytoplankton biomass is typically variable (spatially and temporally), but greatest in areas of upwelling, or in shallow waters where nutrient levels are high.

Primary productivity of the North-west Marine Region is generally low and appears to be largely driven by offshore influences (Brewer *et al.*, 2007), with periodic upwelling events and cyclonic influences driving coastal productivity with nutrient recycling and advection. Within the region, peak primary productivity along the shelf edge occurs in late summer/early autumn. Variation in productivity can also be linked to higher biologically productive period in the area (e.g. mass coral spawning events).

Zooplankton is the faunal component of plankton, comprised of small protozoa, crustaceans (e.g. krill) and the eggs and larvae from larger animals. Zooplankton includes species that drift with the currents and also those that are motile. The inshore ichthyoplankton assemblages are characterised by shallow reef fishes such as blennies (family Blenniidae), damselfish (family Pomacentridae) and north-west snappers (family Lethrinidae), while offshore assemblages are dominated by deep-water and pelagic taxa such as tuna (family Scombridae) and lanternfish (family Myctophidae) (Beckley, Muhling, & Gaughan, 2009). Some of these taxa are commercially and recreationally important species in the region.

4.4.4.2 Benthic invertebrates

Table 4-1 identifies that benthic invertebrates may be a relevant receptor to aspects of the activity occurring within the EMBA, Hydrocarbon Area, Mixing Zone and Operational Area during the Petroleum Activity. The description below provides sufficient details to assess all impacts and risks to benthic invertebrates.

The benthic invertebrates of the NWS region are of low abundance but highly diverse and is comprised largely of borrowing polychaete worms and crustaceans (Rainer, 1991). Echinoderms and molluscs are also common on the continental shelf and slope in this region. The diversity and abundance of benthic invertebrates decreases with distance from the coast over most of the NWS – this may be attributed to increasing depth or increasing distance from terrestrial and coastal organic input (SKM, 1998).

A baseline survey, conducted in May 1996 (BBG, 1996) prior to installation of the Wandoo facilities, concluded that the infaunal assemblage was depauperate, with low numbers of species and low abundance. Most of the common species (small crabs, shrimps and polychaetes) are detritivores, feeding on organic matter in the surface layers of the sediment. This survey also found that most areas were bare of epifauna but occasional epifauna mainly sponges and corals were observed.

A subsequent environmental monitoring study of the benthic infauna conducted in May 1998 post commissioning of the facility (SKM, 1998) found that the overall abundance and richness of infauna was higher than reported for the baseline survey. On a regional scale the infaunal community in the vicinity of the Operational Area is also comparable to those at similar sites on the NWS.

It is unlikely that the infaunal community would have changed significantly from the baseline survey as the infaunal assemblage was depauperate, with low numbers of species and low abundance.

4.4.4.3 Birds

Table 4-1 identifies that birds may be a relevant receptor to aspects of the activity occurring within the EMBA, Hydrocarbon Area, Mixing Zone and Operational Area during the Petroleum Activity. The description below provides sufficient details to assess all impacts and risks to birds.

There are multiple species (or species habitat) of birds that may occur within the Operational Area, Mixing Zone, Hydrocarbon Area and EMBA (Table 4-4). The presence of most species, particularly within the Operational Area, are expected to be of a transitory nature only. Some species within the Hydrocarbon Area and EMBA were identified as displaying important behaviour (e.g. breeding, roosting, foraging), with some also recognised as having Biologically Important Areas (BIAs) (Table 4-4, Table 4-5).

The Operational Area and Mixing Zone is within a breeding BIA for the wedge-tailed shearwater; these BIAs are based on buffer areas surrounding the offshore islands (e.g. within Dampier Archipelago) that are used for nesting by this species (Table 4-5). The wedge-tailed shearwater is a migratory visitor to WA. Estimates indicate more than one million shearwaters migrate to the Pilbara islands each year (DBCA 2017). The wedge-tailed shearwater will excavate burrows on vegetated islands for nesting. Known breeding locations in the North-west Marine Region. Breeding locations within the EMBA include Forestier Island (Sable Island), Bedout Island, Dampier Archipelago, Passage Island, Lowendal Island, islands off Barrow Island (Mushroom, Double and Boodie Islands), islands in the Onslow area (including Airlie, Bessieres, Serrurier, North and South Muiron and Locker Islands), islands in the Freycinet Estuary, and south Shark Bay (Slope, Friday, Lefebvre, Charlie, Freycinet, Double and Baudin Islands) (DEWHA 2008a).

The north-western coast of WA and islands provide important refuge for several seabird and shorebird species. For migratory shorebirds, the rocky shores, sandy beaches, saltmarshes, intertidal flats and mangroves are important feeding and resting habitat during spring and summer (DBCA 2017). Migratory seabirds, including terns and shearwaters, use the islands for nesting (DBCA 2017). Island habitats are important for seabirds as they provide relatively undisturbed roosting and nesting habitats close to oceanic foraging grounds. Oystercatchers, red-capped plovers and beach stone-curlews are among the species that have resident populations; these shorebirds are present throughout the year and nest along the coast and on offshore islands (DBCA 2017).

The fairy, lesser crested and roseate terns may have both a resident sub-population and a migratory population present in the Pilbara (DBCA 2017). These tern species nest in open areas, typically sand scrapes/depressions on the sandy beaches of offshore islands. Within the EMBA these tern species are known to nest within the region of the Ningaloo Marine Park, Muiron and Sunday islands (CALM 2005). The Montebello Islands support the largest breeding population of roseate terns in WA (DEWHA 2008). Caspian terns, little terns, and ospreys have also been known to breed on Serrurier Island and neighbouring inshore islands (DEWHA 2008).

Bedout Island (offshore from Port Hedland) supports one of the largest colonies of brown booby in WA (Figure 4-10); the masked booby, lesser frigatebird, roseate tern and common noddy also breed in the area (DEWHA 2008).

Tropicbird species spend most of their lives at sea, typically found in tropical and subtropical seas around northern Australia. A small sand cay at Bedwell Island, within Clerke Reef in Rowley Shoals Marine Park, is one of very few breeding areas in Western Australia for the Red-tailed tropicbird.

Table 4-4: Bird Species or Species Habitat that may occur within the Project Areas

Scientific Name	Common Name	EPBC Status			Project Areas		
		Threatened Species	Migratory Species	Listed Marine Species	Operational Area & Mixing Zone	Hydrocarbon Area	EMBA
<i>Accipiter hiogaster natalis</i>	Christmas Island Goshawk	E				KO	KO
<i>Acrocephalus orientalis</i>	Oriental Reed-Warbler		W	✓		KO	KO
<i>Actitis hypoleucos</i>	Common Sandpiper		W	✓	MO	KO	KO
<i>Anous minutus</i>	Black Noddy			✓		BKO	BKO
<i>Anous stolidus</i>	Common Noddy		M	✓	MO	BKO	BKO
<i>Anous tenuirostris melanops</i>	Australian Lesser Noddy	V		✓		BKO	BKO
<i>Anseranas semipalmata</i>	Magpie Goose			✓		MO	MO
<i>Apus pacificus</i>	Fork-tailed Swift		M	✓		LO	LO
<i>Ardea alba</i>	Great Egret			✓		BKO	BKO
<i>Ardea ibis</i>	Cattle Egret			✓		MO	MO
<i>Ardenna carneipes</i>	Flesh-footed Shearwater		M	✓		FLO	FLO
<i>Ardenna pacifica</i>	Wedge-tailed Shearwater		M	✓		BKO	BKO
<i>Arenaria interpres</i>	Ruddy Turnstone		W	✓		RKO	RKO
<i>Calidris acuminata</i>	Sharp-tailed Sandpiper		W	✓	MO	RKO	RKO
<i>Calidris alba</i>	Sanderling		W	✓		RKO	RKO
<i>Calidris canutus</i>	Red Knot	E	W	✓	MO	KO	KO
<i>Calidris ferruginea</i>	Curlew Sandpiper	CE	W	✓	MO	KO	KO
<i>Calidris melanotos</i>	Pectoral Sandpiper		W	✓	MO	KO	KO
<i>Calidris ruficollis</i>	Red-necked Stint		W	✓		RKO	RKO
<i>Calidris subminuta</i>	Long-toed Stint		W	✓		KO	KO
<i>Calidris tenuirostris</i>	Great Knot	CE	W	✓		RKO	RKO



Scientific Name	Common Name	EPBC Status			Project Areas		
		Threatened Species	Migratory Species	Listed Marine Species	Operational Area & Mixing Zone	Hydrocarbon Area	EMBA
<i>Calonectris leucomelas</i>	Streaked Shearwater		M	✓	LO	KO	KO
<i>Catharacta skua</i>	Great Skua			✓		MO	MO
<i>Cecropis daurica</i>	Red-rumped Swallow		T			KO	KO
<i>Charadrius bicinctus</i>	Double-banded Plover		W	✓		RKO	RKO
<i>Charadrius leschenaultii</i>	Greater Sand Plover	V	W	✓		RKO	RKO
<i>Charadrius mongolus</i>	Lesser Sand Plover	E	W	✓		RKO	RKO
<i>Charadrius ruficapillus</i>	Red-capped Plover			✓		RKO	RKO
<i>Charadrius veredus</i>	Oriental Plover		W	✓		RKO	RKO
<i>Chrysococcyx osculans</i>	Black-eared Cuckoo			✓		KO	KO
<i>Cuculus optatus</i>	Oriental Cuckoo		T			KO	KO
<i>Diomedea amsterdamensis</i>	Amsterdam Albatross	E	M	✓		LO	LO
<i>Diomedea dabbenena</i>	Tristan Albatross	E	M	✓			LO
<i>Diomedea epomophora</i>	Southern Royal Albatross	V	M	✓		MO	FLO
<i>Diomedea exulans</i>	Wandering Albatross	V	M	✓		MO	FLO
<i>Diomedea sanfordi</i>	Northern Royal Albatross	E	M	✓			FLO
<i>Erythrotriorchis radiatus</i>	Red Goshawk	V				LO	LO
<i>Fregata andrewsi</i>	Christmas Island Frigatebird	E	M	✓		BKO	BKO
<i>Fregata ariel</i>	Lesser Frigatebird		M	✓	LO	BKO	BKO
<i>Fregata minor</i>	Great Frigatebird		M	✓		BKO	BKO
<i>Gallinago megala</i>	Swinhoe's Snipe		W	✓		RLO	RLO
<i>Gallinago stenura</i>	Pin-tailed Snipe		W	✓		RLO	RLO
<i>Glareola maldivarum</i>	Oriental Pratincole		W	✓		RKO	RKO



Scientific Name	Common Name	EPBC Status			Project Areas		
		Threatened Species	Migratory Species	Listed Marine Species	Operational Area & Mixing Zone	Hydrocarbon Area	EMBA
<i>Haliaeetus leucogaster</i>	White-bellied Sea-Eagle			✓		BKO	KO
<i>Halobaena caerulea</i>	Blue Petrel	V		✓			MO
<i>Heteroscelus brevipes</i>	Grey-tailed Tattler			✓		RKO	RKO
<i>Himantopus himantopus</i>	Pied Stilt			✓		RKO	RKO
<i>Hirundo daurica</i>	Red-rumped Swallow			✓		KO	KO
<i>Hirundo rustica</i>	Barn Swallow		T	✓		KO	KO
<i>Hydroprogne caspia</i>	Caspian Tern		M			BKO	BKO
<i>Hypotaenidia phillippensis andrewsi</i>	Buff-banded Rail (Cocos (Keeling) Islands)	E					KO
<i>Larus novaehollandiae</i>	Silver Gull			✓		BKO	BKO
<i>Larus pacificus</i>	Pacific Gull			✓		BKO	BKO
<i>Limicola falcinellus</i>	Broad-billed Sandpiper		W	✓		RKO	RKO
<i>Limnodromus semipalmatus</i>	Asian Dowitcher		W	✓		RKO	RKO
<i>Limosa lapponica</i>	Bar-tailed Godwit		W	✓		KO	KO
<i>Limosa lapponica baueri</i>	Bar-tailed Godwit (baueri)	V				KO	KO
<i>Limosa lapponica menzbieri</i>	Northern Siberian Bar-tailed Godwit	CE				KO	KO
<i>Limosa limosa</i>	Black-tailed Godwit		W	✓		RKO	RKO
<i>Macronectes giganteus</i>	Southern Giant-Petrel	E	M	✓	MO	MO	MO
<i>Macronectes halli</i>	Northern Giant Petrel	V	M	✓		MO	MO
<i>Malurus leucopterus edouardi</i>	White-winged Fairy-wren (Barrow Island)	V				LO	LO
<i>Malurus leucopterus leucopterus</i>	White-winged Fairy-wren (Dirk Hartog Island),	V					LO

Scientific Name	Common Name	EPBC Status			Project Areas		
		Threatened Species	Migratory Species	Listed Marine Species	Operational Area & Mixing Zone	Hydrocarbon Area	EMBA
<i>Merops ornatus</i>	Rainbow Bee-eater			✓		MO	MO
<i>Motacilla cinerea</i>	Grey Wagtail		T	✓		KO	KO
<i>Motacilla flava</i>	Yellow Wagtail		T	✓		KO	KO
<i>Numenius madagascariensis</i>	Eastern Curlew	CE	W	✓	MO	KO	KO
<i>Numenius minutus</i>	Little Curlew		W	✓		RKO	RKO
<i>Numenius phaeopus</i>	Whimbrel		W	✓		RKO	RKO
<i>Onychoprion anaethetus</i>	Bridled Tern		M			BKO	BKO
<i>Pachyptila turtur</i>	Fairy Prion			✓			LO
<i>Pachyptila turtur subantarctica</i>	Fairy Prion (southern)	V					MO
<i>Pandion haliaetus</i>	Osprey		W	✓	MO	BKO	BKO
<i>Papasula abbotti</i>	Abbott's Booby	E		✓		KO	KO
<i>Pelagodroma marina</i>	White-faced Storm-Petrel			✓		BKO	BKO
<i>Phaethon lepturus</i>	White-tailed Tropicbird		M	✓		BKO	BKO
<i>Phaethon lepturus fulvus</i>	Christmas Island White-tailed Tropicbird	E		✓		BLO	BLO
<i>Phaethon rubricauda</i>	Red-tailed Tropicbird		M	✓		BKO	BKO
<i>Phalacrocorax fuscescens</i>	Black-faced Cormorant			✓		BLO	BLO
<i>Phalaropus lobatus</i>	Red-necked Phalarope		W	✓		KO	KO
<i>Philomachus pugnax</i>	Ruff (Reeve)		W	✓		RKO	RKO
<i>Phoebastria fusca</i>	Sooty Albatross	V	M	✓			MO
<i>Pluvialis fulva</i>	Pacific Golden Plover		W	✓		RKO	RKO
<i>Pluvialis squatarola</i>	Grey Plover		W	✓		RKO	RKO
<i>Pterodroma arminjoniana</i>	Round Island Petrel	CE				MO	MO

Scientific Name	Common Name	EPBC Status			Project Areas		
		Threatened Species	Migratory Species	Listed Marine Species	Operational Area & Mixing Zone	Hydrocarbon Area	EMBA
<i>Pterodroma macroptera</i>	Great-winged Petrel			✓		FKO	FKO
<i>Pterodroma mollis</i>	Soft-plumaged Petrel	V		✓		FLO	FKO
<i>Puffinus assimilis</i>	Little Shearwater			✓		FKO	BKO
<i>Puffinus carneipes</i>	Flesh-footed Shearwater			✓		FLO	FLO
<i>Puffinus huttoni</i>	Hutton's Shearwater			✓			FKO
<i>Recurvirostra novaehollandiae</i>	Red-necked Avocet			✓		RKO	RKO
<i>Rostratula australis</i>	Australian Painted-snipe	E		✓		KO	KO
<i>Rostratula benghalensis (sensu lato)</i>	Painted Snipe	E		✓		KO	KO
<i>Sterna anaethetus</i>	Bridled Tern			✓		BKO	BKO
<i>Sterna bengalensis</i>	Lesser Crested Tern			✓		BKO	BKO
<i>Sterna bergii</i>	Crested Tern		W	✓		BKO	BKO
<i>Sterna caspia</i>	Caspian Tern			✓		BKO	BKO
<i>Sterna dougallii</i>	Roseate Tern		M	✓		BKO	BKO
<i>Sterna fuscata</i>	Sooty Tern			✓		BKO	BKO
<i>Sterna nereis</i>	Fairy Tern			✓		BKO	BKO
<i>Sternula albifrons</i>	Little Tern		M	✓		BKO	BKO
<i>Sternula nereis nereis</i>	Australian Fairy Tern	V			FLO	BKO	BKO
<i>Stiltia isabella</i>	Australian Pratincole			✓		RKO	RKO
<i>Sula dactylatra</i>	Masked Booby		M	✓		BKO	BKO
<i>Sula leucogaster</i>	Brown Booby		M	✓		BKO	BKO
<i>Sula sula</i>	Red-footed Booby		M	✓		BKO	BKO
<i>Thalassarche carteri</i>	Indian Yellow-nosed Albatross	V	M	✓		FMO	FMO



Scientific Name	Common Name	EPBC Status			Project Areas		
		Threatened Species	Migratory Species	Listed Marine Species	Operational Area & Mixing Zone	Hydrocarbon Area	EMBA
<i>Thalassarche cauta</i>	Tasmanian Shy Albatross	V	M	✓			FLO
<i>Thalassarche cauta cauta</i>	Shy Albatross	V	M	✓		MO	FLO
<i>Thalassarche cauta steadi</i>	White-capped Albatross	V	M	✓		FLO	FLO
<i>Thalassarche impavida</i>	Campbell Albatross	V	M	✓		MO	MO
<i>Thalassarche melanophris</i>	Black-browed Albatross	V	M	✓		MO	MO
<i>Thinornis rubricollis</i>	Hooded Plover			✓			KO
<i>Tringa brevipes</i>	Grey-tailed Tattler		W			RKO	RKO
<i>Tringa glareola</i>	Wood Sandpiper		W	✓		RKO	RKO
<i>Tringa nebularia</i>	Common Greenshank		W	✓		KO	KO
<i>Tringa stagnatilis</i>	Marsh Sandpiper		W	✓		RKO	RKO
<i>Tringa totanus</i>	Common Redshank		W	✓		RKO	RKO
<i>Xenus cinereus</i>	Terek Sandpiper		W	✓		RKO	RKO
Threatened Species V Vulnerable E Endangered CE Critically Endangered Migratory Species M Marine W Wetland T Terrestrial		Type of Presence MO Species of species habitat may occur within area LO Species or species habitat likely to occur within area KO Species or species habitat known to occur within area FMO Foraging, feeding or related behaviour may occur within area FLO Foraging, feeding or related behaviour likely to occur within area FKO Foraging, feeding or related behaviour known to occur within area BLO Breeding likely to occur within area BKO Breeding known to occur within area RLO Roosting likely to occur within area RKO Roosting known to occur within area CKO Congregation or aggregation known to occur within area					

Table 4-5: Biologically Important Areas for relevant seabird and shorebird species

Species	BIA Presence			Summary Description of BIA
	Operational Area & Mixing Zone	Hydrocarbon Area	EMBA	
Common Noddy (<i>Anous stolidus</i>)			f	Foraging grounds lie around islands used for breeding such as the Abrolhos with presence likely to occur mid-August to late-April.
Australian Lesser Noddy (<i>Anous tenuirostris melanops</i>)			f	Foraging grounds lie around islands used for breeding such as the Abrolhos with the potential for presence throughout the year.
Wedge-tailed Shearwater (<i>Ardenna pacifica</i>)	b	b,f	b,f	Breeding grounds and buffer area around offshore islands including Bedout Island, Dampier Archipelago, Forestier Islands, Montebello and Lowendal Islands. Breeding presence may occur between mid-August to April (Pilbara) or to mid-May (Shark Bay).
Lesser Frigatebird (<i>Fregata ariel</i>)		b	b	Breeding grounds and buffer area around offshore islands in the Pilbara and Kimberley (including Bedout Island). Breeding season from March to September.
Greater Frigatebird (<i>Fregata minor</i>)		b	b	Breeding on Ashmore Reef and Adele Island. Breeding in May-June and August.
Pacific Gull (<i>Larus pacificus</i>)			f	Foraging grounds generally within inshore waters along the west coast and around Abrolhos Islands.
White-tailed Tropicbird (<i>Phaethon lepturus</i>)		b	b	Breeding grounds and buffer area around offshore islands in the Pilbara and Kimberley (including Rowley Shoals). Breeding recorded between May and October.
Great-winged Petrel (<i>Pterodroma macroptera</i>)			f	Suitable foraging habitat inshore, offshore and pelagic. Late-January to early-December.
Soft-plumaged Petrel (<i>Pterodroma mollis</i>)			f	Oceanic foraging grounds are on continental shelf waters and not observed inshore. Presence may occur March to Late September.
Little Shearwater (<i>Puffinus assimilis</i>)			f	Oceanic foraging grounds extend 4 – 200km offshore between Kalbarri and Eucla, with high usage around Abrolhos Islands. Presence mainly occurs April to November.
Bridled Tern (<i>Sterna anaethetus</i>)		f	f	Oceanic foraging grounds with presence generally driven by breeding season, late-September to late-february/ early-May.



Species	BIA Presence			Summary Description of BIA
	Operational Area & Mixing Zone	Hydrocarbon Area	EMBA	
Caspian Tern (<i>Sterna caspia</i>)			f	Oceanic foraging grounds.
Roseate Tern (<i>Sterna dougallii</i>)		b,r	b,f,r	Breeding grounds and buffer area around offshore islands in Gascoyne, Pilbara and Kimberly. Breeding presence may occur mid-March to July. Oceanic foraging grounds on west coast and round Abrolhos Islands. Resting area located northern end of Eighty Mile Beach.
Sooty Tern (<i>Sterna fuscata</i>)		f	f	Oceanic foraging grounds; common in Abrolhos area but in small numbers. Presence associated with breeding season from late-August to early-May.
Fairy Tern (<i>Sterna nereis</i>)		b	b,f	Breeding grounds and buffer area around offshore islands in Gascoyne and Pilbara. Breeding may occur late-July to September. Oceanic foraging grounds on west coast and round Abrolhos Islands.
Little Tern (<i>Sternula albifrons</i>)		b,r	b,r	Breeding grounds and buffer area and resting areas, around offshore islands in Pilbara and Kimberley. Breeding has been recorded June to October.
Brown Booby (<i>Sula leucogaster</i>)		b	b	Breeding grounds and buffer area around offshore islands in Pilbara and Kimberley (including Bedout Island). Breeding presence may occur February to October.
Red-footed Booby (<i>Sula sula</i>)		b	b	Breeding grounds and buffer areas stounf offshore islands and reef areas in the Kimberley (e.g. Ashmore Reef, Adele Island). Breeding typically occurs May to June.
Lesser Crested Tern (<i>Thalasseus bengalensis</i>)		b	b	Breeding grounds and buffer area around offshore islands in Gascoyne, Pilbara and Kimberley (including Lowendal Islands and Bedout Island). Breeding may occur March to June.
Biologically Important Areas				
b Breeding				
f Foraging				
r Resting				

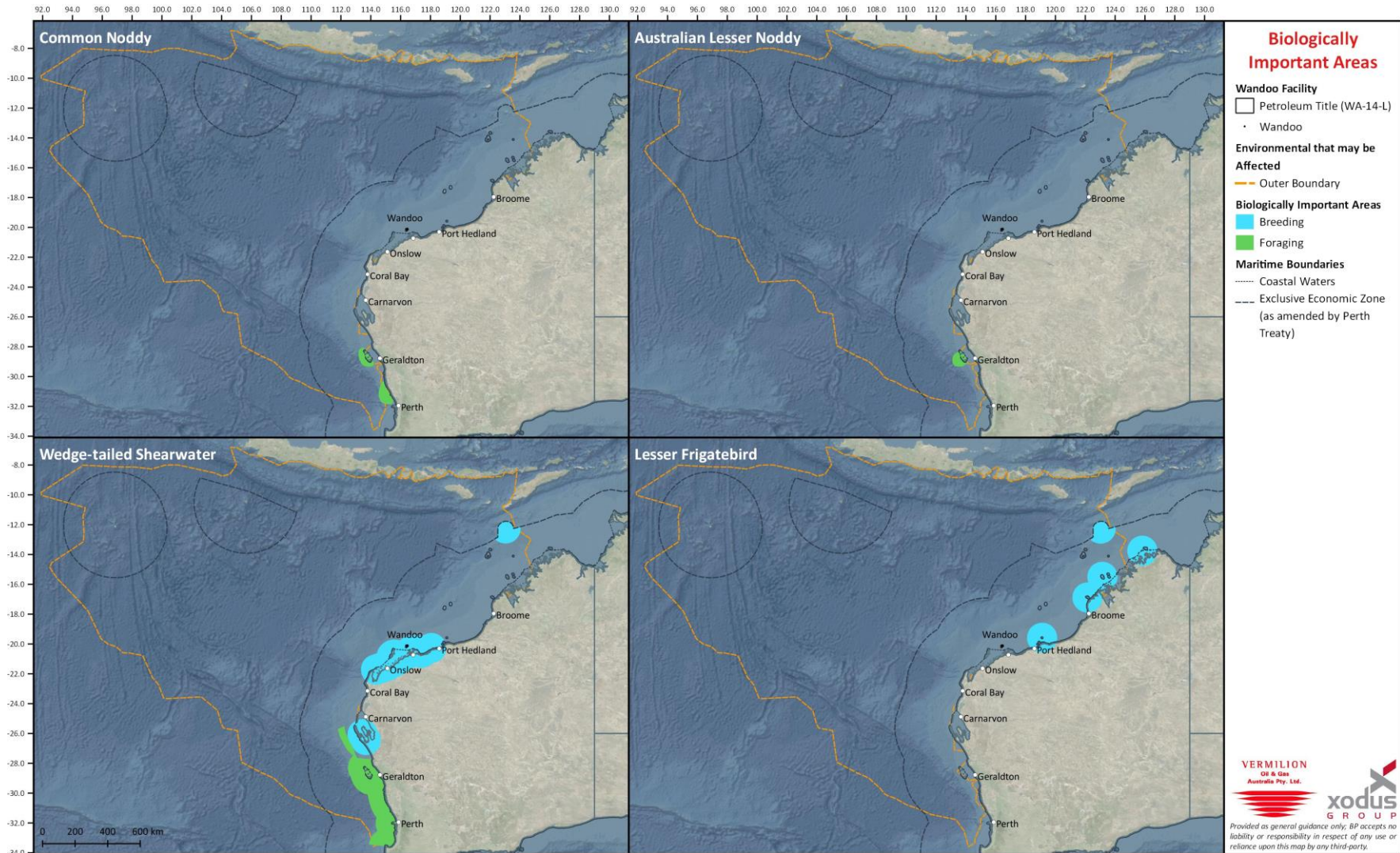

Figure 4-6: Biologically Important Areas for Bird Species (Common Noddy, Australian Lesser Noddy, Wedge-tailed Shearwater, Lesser Frigatebird)

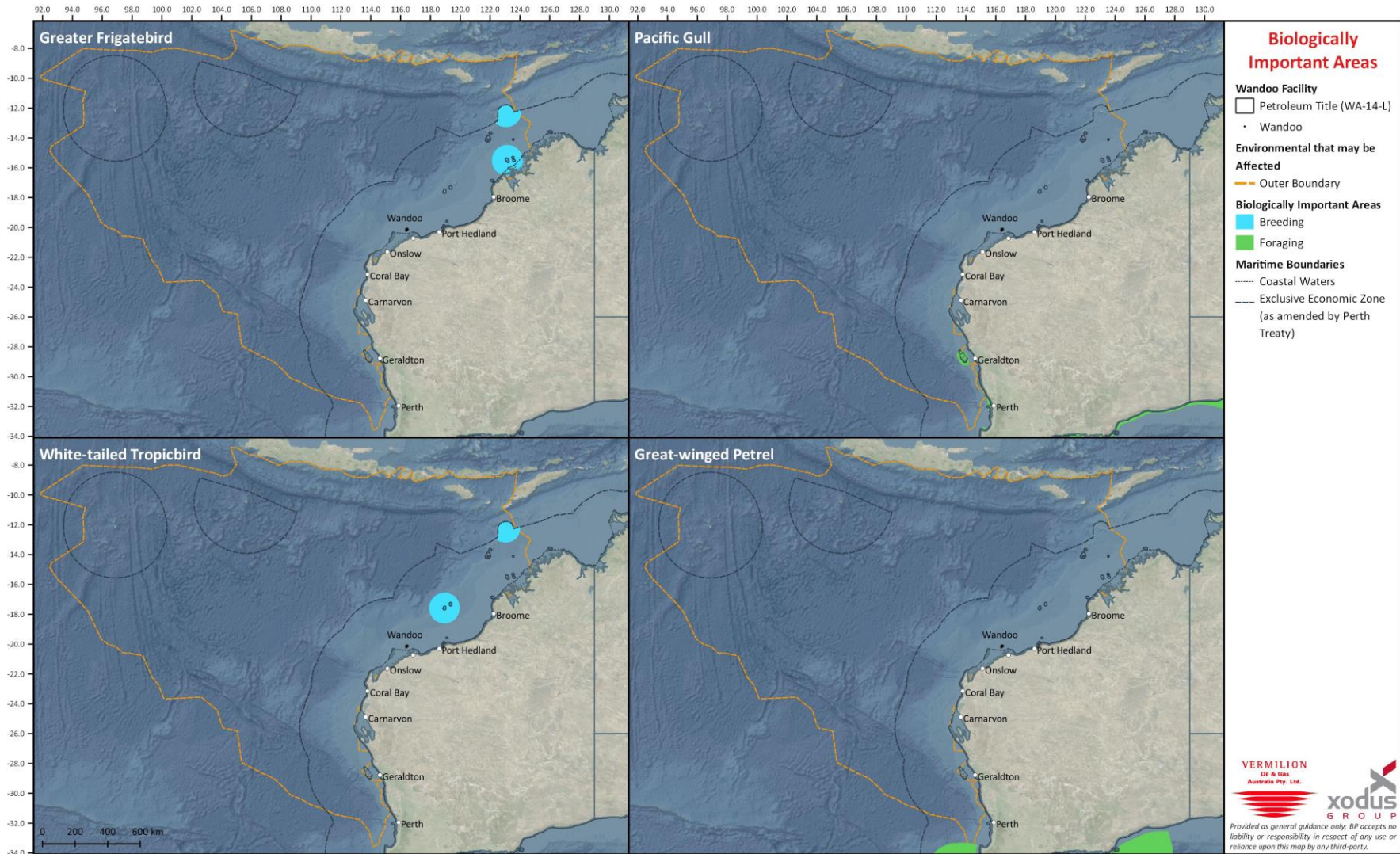

Figure 4-7: Biologically Important Areas for Bird Species (Greater Frigatebird, Pacific Gull, White-tailed Tropicbird, Great-winged Petrel)

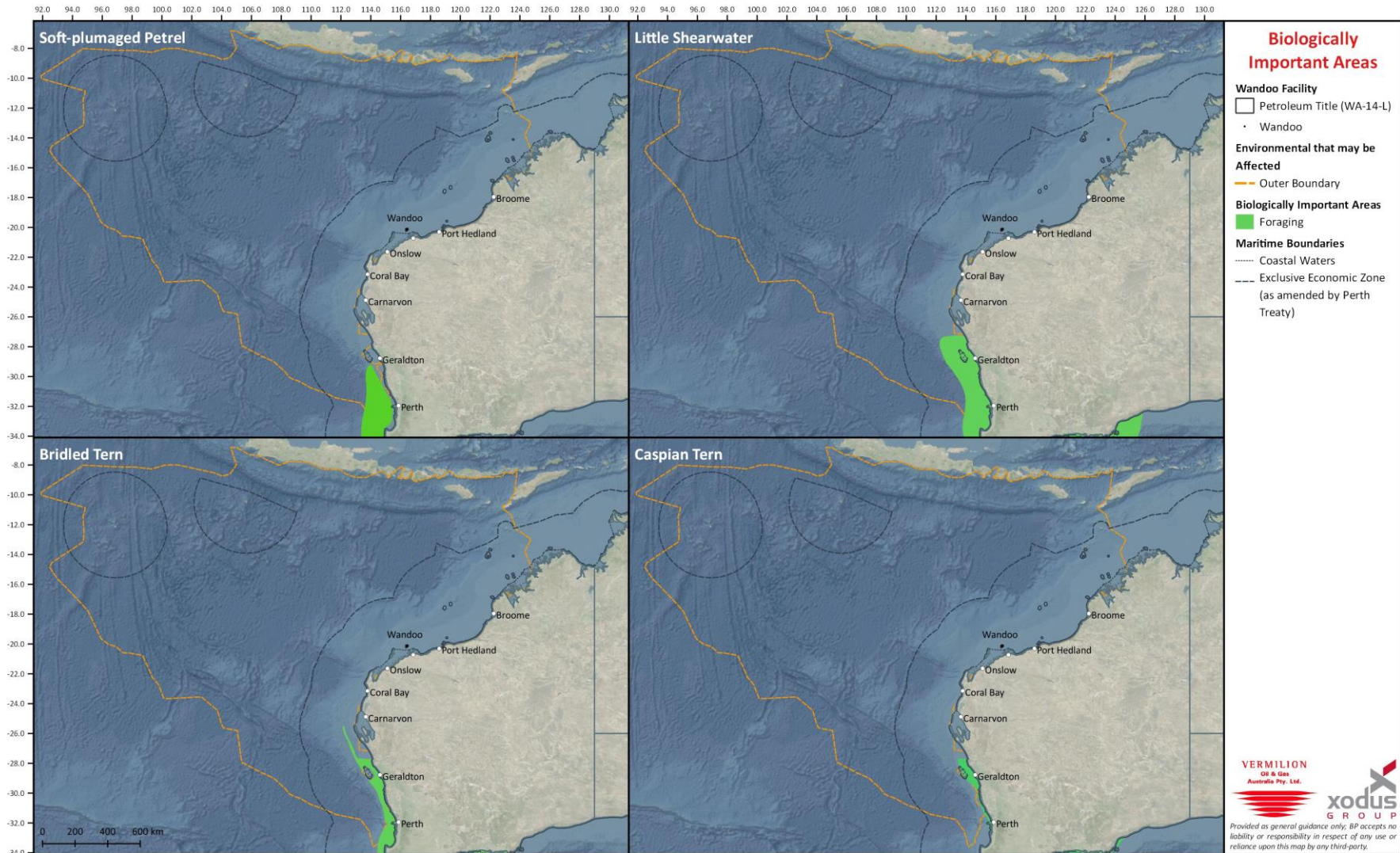

Figure 4-8: Biologically Important Areas for Bird Species (Soft-plumaged Petrel, Little Shearwater, Bridled Tern, Caspian Tern)

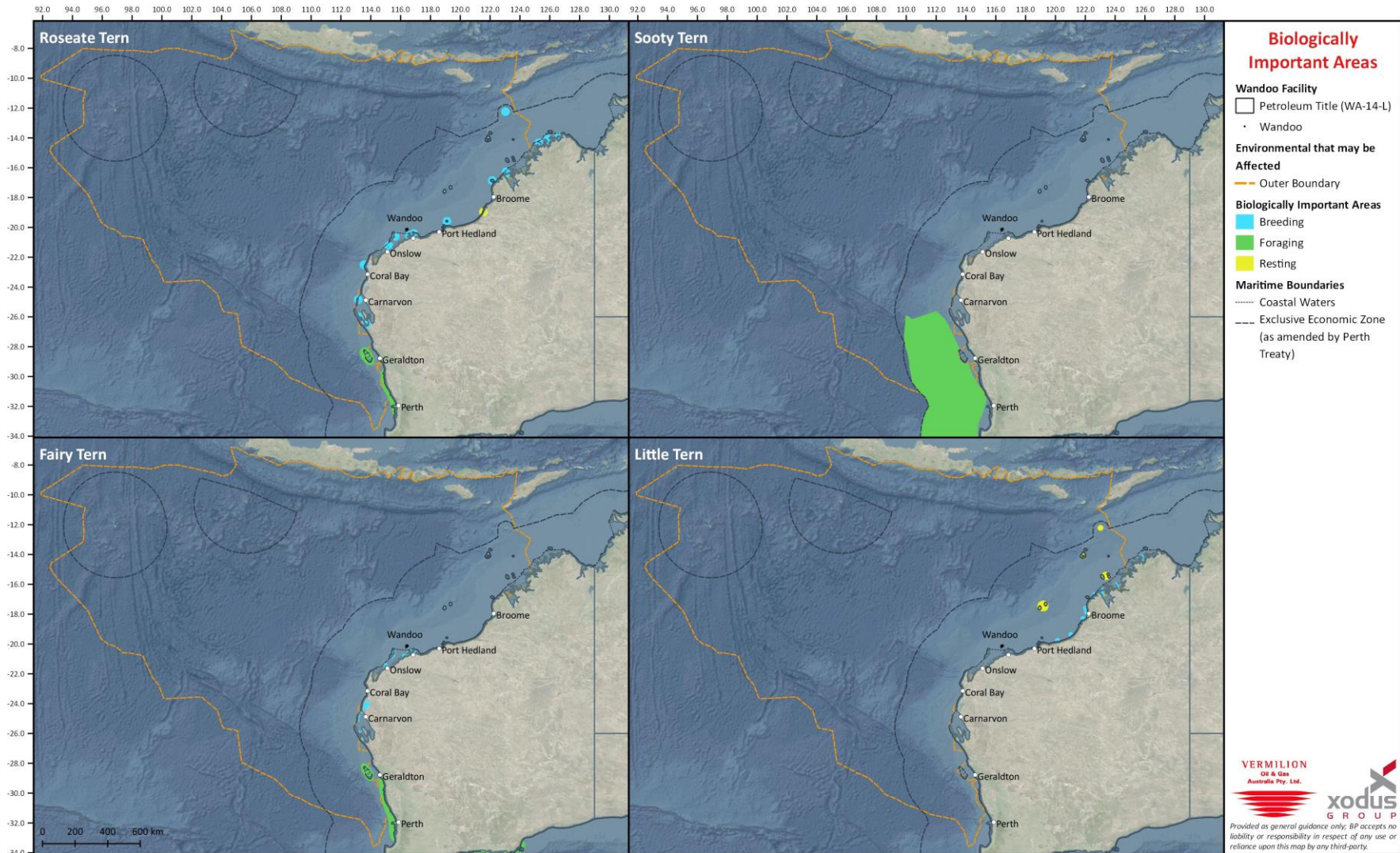

Figure 4-9: Biologically Important Areas for Bird Species (Roseate Tern, Sooty Tern, Fairy Tern, Little Tern)

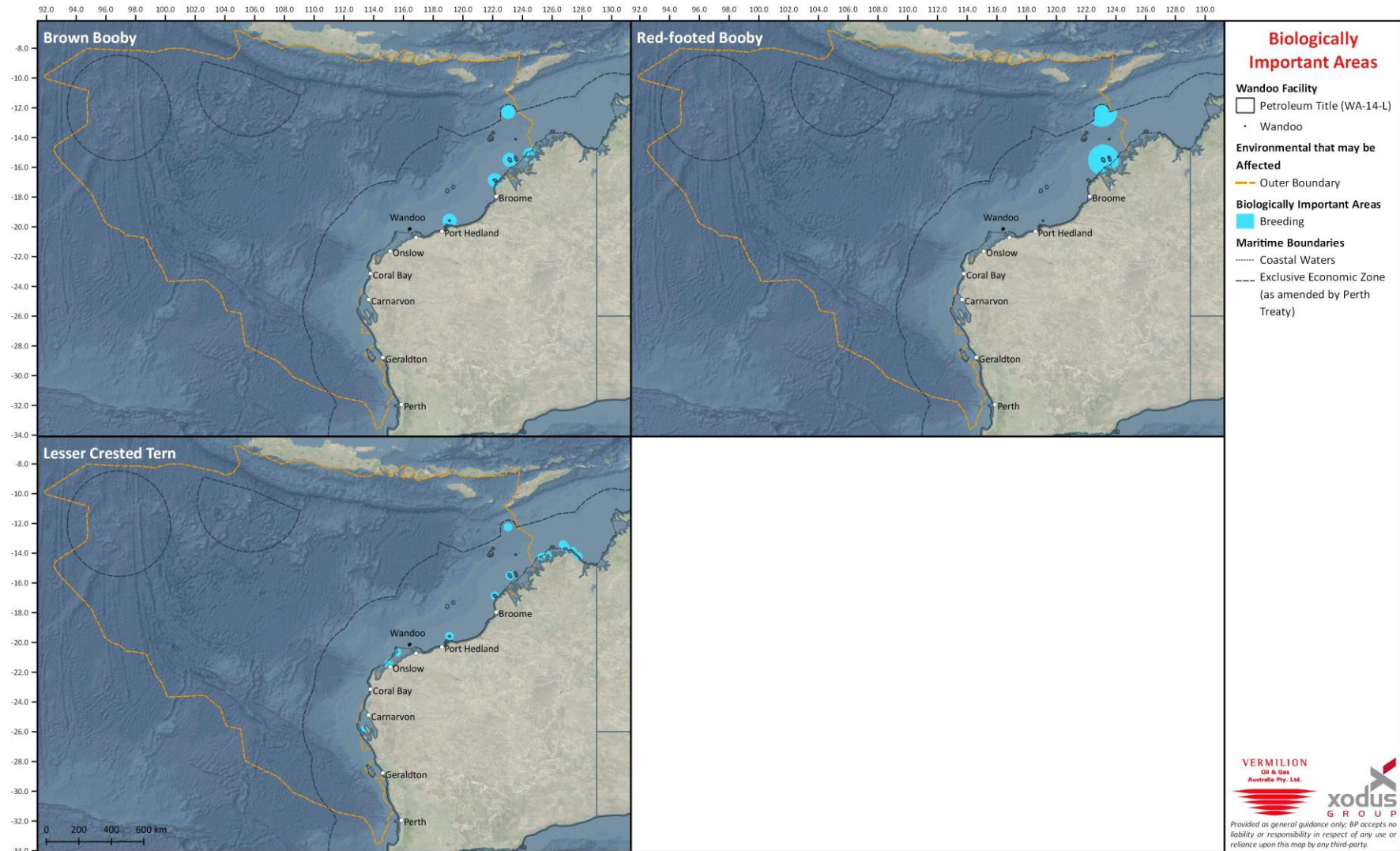

Figure 4-10: Biologically Important Areas for Bird Species (Brown Booby, Red-footed Booby, Lesser Crested Tern)

4.4.4.4 Fish and sharks

Table 4-1 identifies that fish and sharks may be a relevant receptor to aspects of the activity occurring within the EMBA, Hydrocarbon Area, Mixing Zone and Operational Area. The description below provides sufficient details to assess all impacts and risks to fish and sharks.

There are multiple species (or species habitats) of fish and sharks that may occur within the Operational Area, Mixing Zone, Hydrocarbon Area and EMBA (Table 4-6). The presence of most species within the Operational Area and Mixing Zone is expected to be of a transitory nature only. Some species within the Hydrocarbon Area and EMBA were identified as displaying important behaviour (e.g. breeding, foraging), with some also recognised as having Biologically Important Areas (BIAs) (Table 4-6, Table 4-7).

The Operational Area and Mixing Zone is within a foraging BIA for the whale shark (Table 4-7, Figure 4-11). However, it is known that the whale sharks are more common migrating along the 200 m depth contour, which is further offshore to the Wandoo facility. The whale shark is widely distributed in Australian waters; but Ningaloo Reef is the main known aggregation area (DEWHA 2008b). Whale sharks aggregate at Ningaloo between March and June each year to feed. The whale shark is a suction filter feeder, with a diet consisting of planktonic and nektonic prey, and feeds at or close to the water's surface by swimming forward with mouth agape, sucking in prey (DoEE 2017b). While the species is generally encountered close to or at the surface, it will regularly dive and move through the water column.

Much of the seabed in the immediate vicinity of the Operational Area and Mixing Zone is flat and unvegetated soft sediment. Consequently, the demersal fish fauna abundance and diversity is likely to be lower as compared to nearshore vegetated areas or offshore areas with complex topography.

The fish communities of the Northwest Province are diverse, with high level of endemism in demersal fish communities on the slope. Fish species commonly found on the inner shelf include lizardfish, goatfish, trevally, angelfish and tuskfish; and fish species commonly found in slightly deeper (100–200 m) shelf water include deep goatfish, deep lizardfish, ponyfish, deep threadfin bream, adult trevally, billfish and tuna (DEWHA 2008). Fish found in water depths up to 300 m include grouper and snapper species (Rome and Newman 2010). Spanish mackerel spawn in the region between August and November. A small aggregation of the vulnerable grey nurse sharks has been identified off Exmouth during a five-year (2007–2012) study (Hosche and Whisson 2016). Aggregation sites are important in the life cycle of the grey nurse shark for mating and pupping (Hosche and Whisson 2016).

Previous consultation with the Department of Fisheries (DoF; now Department of Primary Industries and Regional Development [DPIRD]) identified that a number of commercial fish species have spawning areas with the EMBA. Their spawning and aggregation times are outlined in Table 4-17.

Table 4-6: Fish and Shark Species or Species Habitat that may occur within the Project Areas

Scientific Name	Common Name	EPBC Status			Project Areas		
		Threatened Species	Migratory Species	Listed Marine Species	Operational Area & Mixing Zone	Hydrocarbon Area	EMBA
Sharks and Rays							
<i>Anoxypristis cuspidata</i>	Narrow Sawfish		M		MO	KO	KO
<i>Carcharias taurus</i> (west coast population)	Grey Nurse Shark (west coast population)	V			LO	KO	KO
<i>Carcharodon carcharias</i>	White Shark	V	M		MO	KO	FKO
<i>Carcharhinus longimanus</i>	Oceanic Whitetip Shark		M		LO	LO	LO
<i>Glyphis garricki</i>	Northern River Shark	E				BLO	BLO
<i>Isurus oxyrinchus</i>	Shortfin Mako		M		LO	LO	LO
<i>Isurus paucus</i>	Longfin Mako		M		LO	LO	LO
<i>Lamna nasus</i>	Porbeagle		M			MO	MO
<i>Manta alfredi</i>	Reef Manta Ray		M		KO	KO	KO
<i>Manta birostris</i>	Giant Manta Ray		M		LO	KO	KO
<i>Pristis clavata</i>	Dwarf Sawfish	V	M		KO	BKO	BKO
<i>Pristis pristis</i>	Freshwater Sawfish	V	M			KO	KO
<i>Pristis zijsron</i>	Green Sawfish	V	M		KO	BKO	BKO
<i>Rhincodon typus</i>	Whale Shark	V	M		FKO	FKO	FKO
Other							
<i>Acentronura australe</i>	Southern Pygmy Pipehorse			✓		MO	MO
<i>Acentronura larsonae</i>	Helen's Pygmy Pipehorse			✓	MO	MO	MO
<i>Bhanotia fasciolata</i>	Corrugated Pipefish			✓	MO	MO	MO
<i>Bulbonaricus brauni</i>	Braun's Pughead Pipefish			✓		MO	MO

Scientific Name	Common Name	EPBC Status			Project Areas		
		Threatened Species	Migratory Species	Listed Marine Species	Operational Area & Mixing Zone	Hydrocarbon Area	EMBA
<i>Campichthys galei</i>	Gale's Pipefish			✓		MO	MO
<i>Campichthys tricarinatus</i>	Three-keel Pipefish			✓	MO	MO	MO
<i>Choeroichthys brachysoma</i>	Pacific Short-bodied Pipefish			✓	MO	MO	MO
<i>Choeroichthys latispinosus</i>	Muiron Island Pipefish			✓	MO	MO	MO
<i>Choeroichthys sculptus</i>	Sculptured Pipefish			✓		MO	MO
<i>Choeroichthys suillus</i>	Pig-snouted Pipefish			✓	MO	MO	MO
<i>Corythoichthys amplexus</i>	Fijian Banded Pipefish			✓		MO	MO
<i>Corythoichthys flavofasciatus</i>	Reticulate Pipefish			✓		MO	MO
<i>Corythoichthys haematopterus</i>	Reef-top Pipefish			✓		MO	MO
<i>Corythoichthys intestinalis</i>	Australian Messmate Pipefish			✓		MO	MO
<i>Corythoichthys schultzi</i>	Schultz's Pipefish			✓		MO	MO
<i>Cosmocampus banneri</i>	Roughridge Pipefish			✓		MO	MO
<i>Cosmocampus maxweberi</i>	Maxweber's Pipefish			✓		MO	MO
<i>Doryrhamphus baldwini</i>	Redstripe Pipefish			✓		MO	MO
<i>Doryrhamphus dactyliophorus</i>	Banded Pipefish			✓	MO	MO	MO
<i>Doryrhamphus excisus</i>	Bluestripe Pipefish			✓		MO	MO
<i>Doryrhamphus janssi</i>	Cleaner Pipefish			✓	MO	MO	MO
<i>Doryrhamphus multiannulatus</i>	Many-banded Pipefish			✓	MO	MO	MO
<i>Doryrhamphus negrosensis</i>	Flagtail Pipefish			✓	MO	MO	MO
<i>Festucalex scalaris</i>	Ladder Pipefish			✓	MO	MO	MO
<i>Filicampus tigris</i>	Tiger Pipefish			✓	MO	MO	MO
<i>Halicampus brocki</i>	Brock's Pipefish			✓	MO	MO	MO

Scientific Name	Common Name	EPBC Status			Project Areas		
		Threatened Species	Migratory Species	Listed Marine Species	Operational Area & Mixing Zone	Hydrocarbon Area	EMBA
<i>Halicampus dunckeri</i>	Red-hair Pipefish			✓		MO	MO
<i>Halicampus grayi</i>	Mud Pipefish			✓	MO	MO	MO
<i>Halicampus macrorhynchus</i>	Whiskered Pipefish			✓		MO	MO
<i>Halicampus mataafae</i>	Samoan Pipefish			✓		MO	MO
<i>Halicampus nitidus</i>	Glittering Pipefish			✓	MO	MO	MO
<i>Halicampus spinostris</i>	Spiny-snout Pipefish			✓	MO	MO	MO
<i>Haliichthys taeniophorus</i>	Ribboned Pipehorse			✓	MO	MO	MO
<i>Heraldia nocturna</i>	Upside-down Pipefish			✓			MO
<i>Hippichthys cyanospilos</i>	Blue-speckled Pipefish			✓		MO	MO
<i>Hippichthys heptagonus</i>	Madura Pipefish			✓		MO	MO
<i>Hippichthys penicillus</i>	Beady Pipefish			✓	MO	MO	MO
<i>Hippichthys spicifer</i>	Belly-barred Pipefish			✓		MO	MO
<i>Hippocampus angustus</i>	Western Spiny Seahorse			✓	MO	MO	MO
<i>Hippocampus breviceps</i>	Short-head Seahorse			✓		MO	MO
<i>Hippocampus histrix</i>	Spiny Seahorse			✓	MO	MO	MO
<i>Hippocampus kuda</i>	Spotted Seahorse			✓	MO	MO	MO
<i>Hippocampus planifrons</i>	Flat-face Seahorse			✓	MO	MO	MO
<i>Hippocampus spinosissimus</i>	Hedgehog Seahorse			✓		MO	MO
<i>Hippocampus subelongatus</i>	West Australian Seahorse			✓		MO	MO
<i>Hippocampus trimaculatus</i>	Three-spot Seahorse			✓	MO	MO	MO
<i>Histiogamphelus cristatus</i>	Rhino Pipefish			✓			MO
<i>Lissocampus caudalis</i>	Australian Smooth Pipefish			✓			MO

Scientific Name	Common Name	EPBC Status			Project Areas		
		Threatened Species	Migratory Species	Listed Marine Species	Operational Area & Mixing Zone	Hydrocarbon Area	EMBA
<i>Lissocampus fatiloquus</i>	Prophet's Pipefish			✓		MO	MO
<i>Lissocampus runa</i>	Javelin Pipefish			✓			MO
<i>Maroubra perserrata</i>	Sawtooth Pipefish			✓		MO	MO
<i>Micrognathus brevisrostris</i>	Thorntail Pipefish			✓		MO	MO
<i>Micrognathus micronotopterus</i>	Tidepool Pipefish			✓	MO	MO	MO
<i>Mitotichthys meraculus</i>	Western Crested Pipefish			✓		MO	MO
<i>Nannocampus subosseus</i>	Bonyhead Pipefish			✓		MO	MO
<i>Phoxocampus belcheri</i>	Black Rock Pipefish			✓	MO	MO	MO
<i>Phycodurus eques</i>	Leafy Seadragon			✓		MO	MO
<i>Phyllopteryx taeniolatus</i>	Common Seadragon			✓		MO	MO
<i>Pugnaso curtirostris</i>	Pugnose Pipefish			✓		MO	MO
<i>Solegnathus hardwickii</i>	Pallid Pipehorse			✓	MO	MO	MO
<i>Solegnathus lettiensis</i>	Gunther's Pipehorse			✓	MO	MO	MO
<i>Solenostomus cyanopterus</i>	Robust Ghostpipefish			✓	MO	MO	MO
<i>Stigmatopora argus</i>	Spotted Pipefish			✓		MO	MO
<i>Stigmatopora nigra</i>	Widebody Pipefish			✓		MO	MO
<i>Syngnathoides biaculeatus</i>	Double-end Pipehorse			✓	MO	MO	MO
<i>Trachyrhamphus bicoarctatus</i>	Bentstick Pipefish			✓	MO	MO	MO
<i>Trachyrhamphus longirostris</i>	Straightstick Pipefish			✓	MO	MO	MO
<i>Urocampus carinirostris</i>	Hairy Pipefish			✓		MO	MO
<i>Vanacampus margaritifer</i>	Mother-of-pearl Pipefish			✓		MO	MO
<i>Vanacampus phillipi</i>	Port Phillip Pipefish			✓			MO



Scientific Name	Common Name	EPBC Status			Project Areas		
		Threatened Species	Migratory Species	Listed Marine Species	Operational Area & Mixing Zone	Hydrocarbon Area	EMBA
<i>Vanacampus poecilolameus</i>	Longsnout Pipefish			✓			MO
Threatened Species V Vulnerable E Endangered Migratory Species M Marine		Type of Presence MO Species of species habitat may occur within area LO Species or species habitat likely to occur within area KO Species or species habitat known to occur within area FKO Foraging, feeding or related behaviour known to occur within area BKO Breeding known to occur within area					

Table 4-7: Biologically important areas for relevant marine fish species

Species	BIA Presence			Summary Description of BIA
	Operational Area	Hydrocarbon Area	EMBA	
White Shark (<i>Carcharodon Carcharias</i>)			f	Foraging grounds around Abrolhos Islands and is associated with sea lion colonies along the south-west coast between Dongara and Augusta.
Whale Shark (<i>Rhincodon typus</i>)	f	f	f	Oceanic foraging ground: known to travel along the 200 m depth contour. Presence may occur during spring. Ningaloo Reef foraging grounds: high density prey. Between April and June, and in Autumn.
Dwarf Sawfish (<i>Pristis clavate</i>)		f,n,p	f,j,n,p	Inshore foraging, pupping and nursery area along Eighty Mile Beach with nursery area at Fitzroy River Mouth, May and Robinson River.
Freshwater Sawfish (<i>Pristis pristis</i>)		f,j,n,p	f,j,n,p	Inshore foraging and pupping area along Eighty Mile Beach. Foraging, pupping and nursery area at Roebuck Bay. Pupping occurs from January to May. Foraging and nursing occurs in King Sound.
Green Sawfish (<i>Pristis zijsron</i>)		f,n,p	f,n,p	Inshore foraging and pupping area along Eighty Mile Beach. Pupping occurs at Willie Creek. Foraging and pupping area at Roebuck Bay. Pupping occurs from January to May. Foraging and nursing occurs in King Sound. Foraging occurs in Camden Sound.
Biologically Important Areas f Foraging j Juvenile	n Nursing p Pupping			

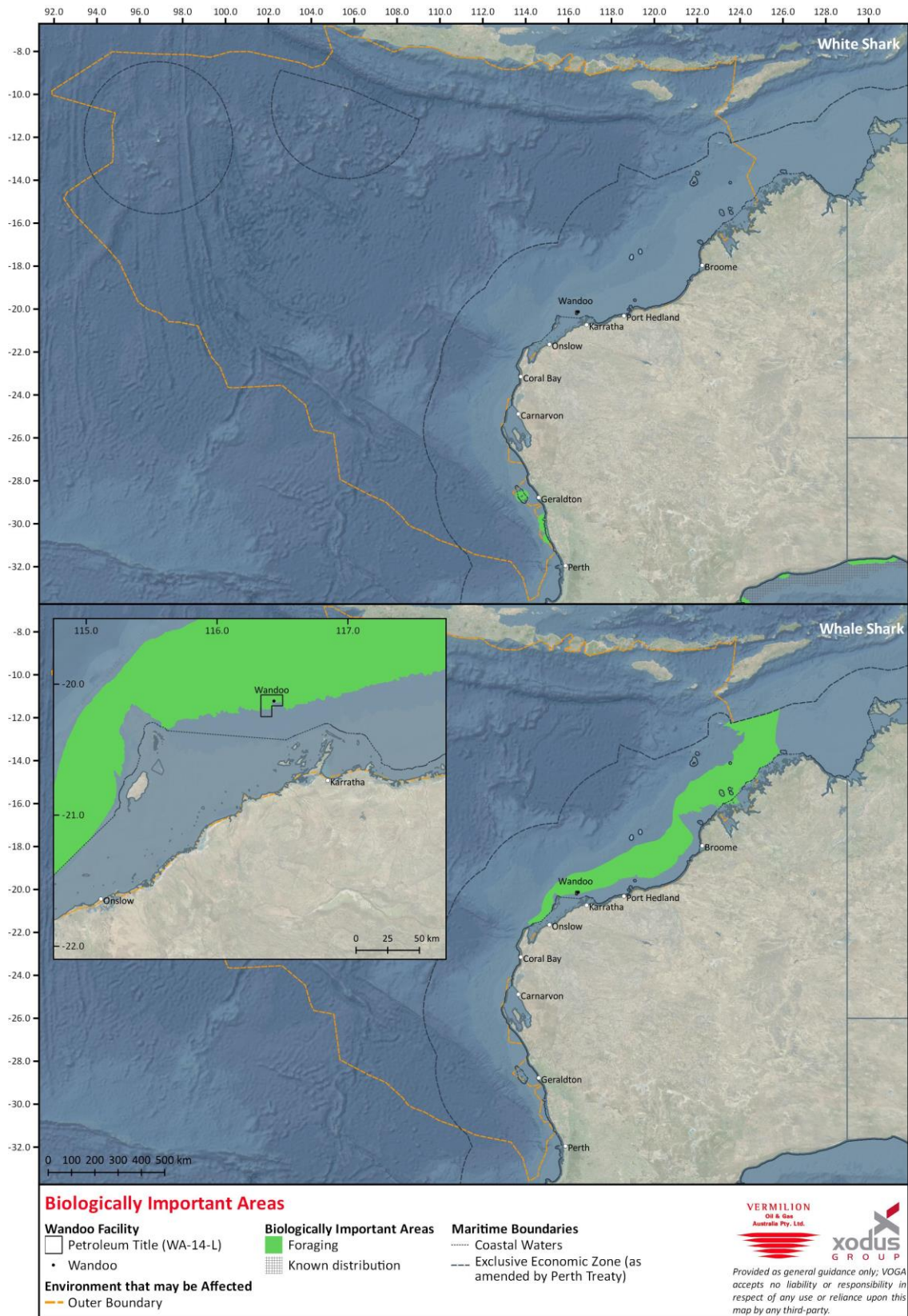

Figure 4-11: Biologically Important Areas for Shark Species (White Shark, Whale Shark)

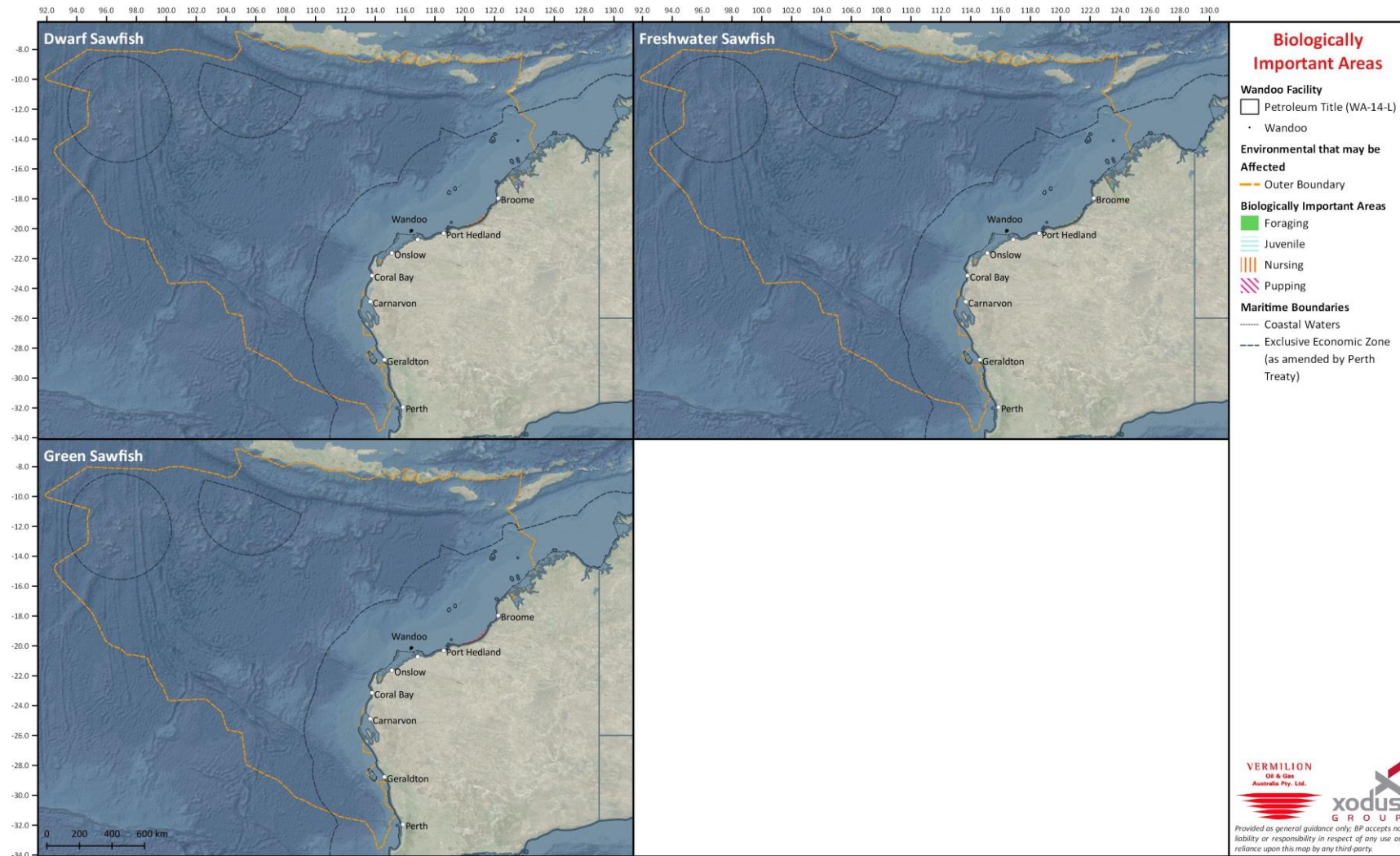

Figure 4-12: Biologically Important Areas for Sawfish Species (Dwarf Sawfish, Freshwater Sawfish, Green Sawfish)

4.4.4.5 Marine mammals

Table 4-1 identifies marine mammals as a relevant receptor to aspects of the activity occurring within the EMBA, Hydrocarbon Area, Mixing Zone and Operational Area during the Petroleum Activity. The description below provides sufficient details to assess all impacts and risks to marine mammals.

There are multiple marine mammal species (or habitat) that may occur within the Operational Area, Mixing Zone, Hydrocarbon Area and EMBA (Table 4-8). The presence of most species within the Operational Area is expected to be of a transitory nature only. Some species within the Hydrocarbon Area and EMBA were identified as displaying important behaviour (e.g. migration, resting), with some also recognised as having Biologically Important Areas (BIAs) (Table 4-8, Table 4-9).

The Operational Area and Mixing Zone is within a migration BIA for the humpback whale, and a distribution BIA for the pygmy blue whale (Table 4-9, Figure 4-13).

There are two subspecies of blue whales found in the southern hemisphere and known to occur in Australian waters: the Antarctic blue whale and the pygmy blue whale. Antarctic blue whales are not expected to occur within the EMBA. Pygmy blue whales are expected to occur; and seasonally important areas within WA include the Perth Canyon. The migratory pathway of pygmy blue whales along the WA coast is reasonably well understood (McCauley and Jenner 2010; DEWHA 2008c) with recent information collected from satellite tags showing that the Banda and Molucca seas in Indonesia is the likely destination for the northern migration of whales that feed off the Perth Canyon (Double et al., 2012; Gales et al 2010; Branch et al 2007).

During the northern migration the pygmy blue whales are around the Perth Canyon area from January to May, and then travel past North West Cape between April to August; and the southern migration typically occurs from October to late-December (DEWHA 2008c). The migratory path for the pygmy blue whales is in deeper waters, typically 500–1,000 m.

Humpback whales migrate north through the EMBA from their Antarctic feeding grounds around May each year, and reach the waters of the North-west Marine Region in early-June (DEWHA 2008c); however, the exact timing of the migration period can vary from year to year. From the North West Cape, northbound humpback whales travel along the edge of the continental shelf passing to the west of the Muiron, Barrow and Montebello Islands, peaking in late July (Jenner et al., 2001).

Breeding and calving grounds are estimated to extend south from Camden Sound to at least North West Cape (Irvine et al., 2018); with breeding and calving occurring between August and September (DEWHA 2008c). This also coincides with the start of the southern migration. Exmouth Gulf and Shark Bay are both important resting areas for migrating humpbacks, particularly for cow-calf pairs on the southern migration (DEWHA 2008). The southerly migration, from around the Lacepede Islands (north of Broome) extends parallel to the coast on approx. the 20–30 m depth contour (Jenner et al., 2001, DEWHA 2008). Southbound migration is more diffuse and irregular, lacking an obvious peak. An increase in southerly migrating individuals may be observed between the North West Cape and the Montebello Islands around November (Jenner et al., 2001).

A significant proportion of the world's dugong population occurs in coastal waters from Shark Bay (WA) to Moreton Bay (QLD) (DEWHA 2008d). Shark Bay occurs outside of the EMBA and supports a significant population of dugongs, with an estimated 10,000 individuals (DEWHA 2008d).

Dugongs are also known to feed and migrate through the Northwest Shelf Province, including regions within the Exmouth Gulf, around North West Cape and offshore on the NWS.

The Exmouth Gulf dugong population is considered stable and the only one not in decline (Oceanwise 2019). Exmouth Gulf is important to this species, as it has been recorded as providing significant breeding and feeding habitat (Jenner and Jenner 2005, Oceanwise 2019). Seagrass is the preferred food of dugongs, but they are also known to eat algae and macroinvertebrates.

Table 4-8: Marine Mammal Species or Species Habitat that may occur within the Project Areas

Scientific Name	Common Name	EPBC Status			Project Areas		
		Threatened Species	Migratory Species	Listed Marine Species	Operational Area & Mixing Zone	Hydrocarbon Area	EMBA
Whales and Dolphins							
<i>Balaenoptera acutorostrata</i>	Minke Whale			✓	MO	MO	MO
<i>Balaenoptera bonaerensis</i>	Antarctic Minke Whale		M	✓		LO	LO
<i>Balaenoptera borealis</i>	Sei Whale	V	M	✓	MO	FLO	FLO
<i>Balaenoptera edeni</i>	Bryde's Whale		M	✓	MO	LO	LO
<i>Balaenoptera musculus</i>	Blue Whale	E	M	✓	LO	MKO	FKO
<i>Balaenoptera physalus</i>	Fin Whale	V	M	✓	MO	FLO	FLO
<i>Caperea marginata</i>	Pygmy Right Whale		M	✓			FLO
<i>Delphinus delphis</i>	Common Dolphin			✓	MO	MO	MO
<i>Eubalaena australis</i>	Southern Right Whale	E	M	✓		LO	BKO
<i>Feresa attenuata</i>	Pygmy Killer Whale			✓		MO	MO
<i>Globicephala macrorhynchus</i>	Short-finned Pilot Whale			✓		MO	MO
<i>Globicephala melas</i>	Long-finned Pilot Whale			✓		MO	MO
<i>Grampus griseus</i>	Risso's Dolphin			✓	MO	MO	MO
<i>Hyperoodon planifrons</i>	Southern Bottlenose Whale			✓			MO
<i>Indopacetus pacificus</i>	Longman's Beaked Whale			✓		MO	MO
<i>Kogia breviceps</i>	Pygmy Sperm Whale			✓		MO	MO
<i>Kogia simus</i>	Dwarf Sperm Whale			✓		MO	MO
<i>Lagenodelphis hosei</i>	Fraser's Dolphin			✓		MO	MO
<i>Lagenorhynchus obscurus</i>	Dusky Dolphin		M	✓			LO
<i>Lissodelphis peronii</i>	Southern Right Whale Dolphin			✓			MO

Scientific Name	Common Name	EPBC Status			Project Areas		
		Threatened Species	Migratory Species	Listed Marine Species	Operational Area & Mixing Zone	Hydrocarbon Area	EMBA
<i>Megaptera novaeangliae</i>	Humpback Whale	V	M	✓	BKO	BKO	BKO
<i>Mesoplodon bowdoini</i>	Andrew's Beaked Whale			✓			MO
<i>Mesoplodon densiro</i>	Blainville's Beaked Whale			✓		MO	MO
<i>Mesoplodon ginkgodens</i>	Gingko-toothed Beaked Whale			✓		MO	MO
<i>Mesoplodon grayi</i>	Gray's Beaked Whale			✓		MO	MO
<i>Mesoplodon layardii</i>	Strap-toothed Beaked Whale			✓			MO
<i>Mesoplodon mirus</i>	True's Beaked Whale			✓			MO
<i>Orcaella brevirostris</i>	Irrawaddy Dolphin			✓		KO	KO
<i>Orcaella heinsohni</i>	Australian Snubfin Dolphin		M			KO	KO
<i>Orcinus orca</i>	Killer Whale		M	✓	MO	MO	MO
<i>Peponocephala electra</i>	Melon-headed Whale			✓			MO
<i>Physeter macrocephalus</i>	Sperm Whale		M	✓		MO	FKO
<i>Pseudorca crassidens</i>	False Killer Whale			✓	LO	LO	LO
<i>Sousa chinensis</i>	Indo-Pacific Humpback Dolphin		M	✓	MO	BKO	BKO
<i>Stenella attenuata</i>	Spotted Dolphin			✓	MO	MO	MO
<i>Stenella coeruleoalba</i>	Striped Dolphin			✓		MO	MO
<i>Stenella longirostris</i>	Long-snouted Spinner Dolphin			✓		MO	MO
<i>Steno bredanensis</i>	Rough-toothed Dolphin			✓		MO	MO
<i>Tursiops aduncus</i>	Indian Ocean Bottlenose Dolphin			✓	MO	LO	LO
<i>Tursiops aduncus</i> (Arafura/Timor Sea populations)	Spotted Bottlenose Dolphin (Arafura/Timor Sea populations)		M	✓	LO	KO	KO
<i>Tursiops truncatus s. str</i>	Bottlenose Dolphin			✓	MO	MO	MO
<i>Ziphius cavirostris</i>	Cuvier's Beaked Whale			✓		MO	MO



Scientific Name	Common Name	EPBC Status			Project Areas		
		Threatened Species	Migratory Species	Listed Marine Species	Operational Area & Mixing Zone	Hydrocarbon Area	EMBA
Pinnipeds							
<i>Arctocephalus forsteri</i>	Long-nosed Fur-seal			✓		MO	MO
<i>Neophoca cinerea</i>	Australian Sea-lion	V		✓		LO	BKO
Sirenians							
<i>Dugong dugon</i>	Dugong		M	✓		BKO	BKO
Threatened Species	Type of Presence						
V Vulnerable	MO Species of species habitat may occur within area						
E Endangered	LO Species or species habitat likely to occur within area						
	KO Species or species habitat known to occur within area						
Migratory Species	FKO Foraging, feeding or related behaviour known to occur within area						
M Marine	BKO Breeding known to occur within area						
	MKO Migration route known to occur within area						
	CKO Congregation or aggregation known to occur within area						

Table 4-9: Biologically important areas for relevant marine mammal species

Species	BIA Presence			Summary Description of BIA
	Operational Area & Mixing Zone	Hydrocarbon Area	EMBA	
Blue Whale, Pygmy Blue Whale (<i>Balaenoptera musculus</i>)	d	d,f,m	d,f,m	Offshore migration corridor, typically along shelf-edge at depths 500–1,000 m, occurring close to the coast around Exmouth. Presence may occur during northern migration past Exmouth area during April to August (whereas January to May past Perth Canyon area). Southern migration presence may occur October to late-December. Foraging along outer continental shelf from Cape Naturaliste to south of Jurien Bay (Nov-June, with peak in March-May).



Species	BIA Presence			Summary Description of BIA
	Operational Area & Mixing Zone	Hydrocarbon Area	EMBA	
Humpback Whale (<i>Megaptera novaeangliae</i>)	m	m,r	c,m,n,r	Migration corridor extends out to ~50–100km from the coast. Migration along the WA coast occurs between May and late November. Winter resting areas identified within Exmouth Gulf and Shark Bay. Calving ground extending from Camden Sound to North West Cape.
Sperm Whale (<i>Physeter macrocephalus</i>)			f	Foraging area associated with abundant food source at Perth Canyon.
Australian Snubfin Dolphin (<i>Orcaella heinsohni</i>)		b,c,f,r	b,c,f,r	Presence in shallow coastal waters and estuaries along the Kimberley coast. Beagle and Pender Bays on the Dampier Peninsula and tidal creeks around Yampi Sound and between Kuri Bay and Cape Londonderry are important areas
Indo-Pacific humpback dolphin (<i>Sousa chinensis</i>)		b,c,f	b,c,f	Breeding grounds in King Sound North, Yampi Sound and Talbot Bay Fjord area. Foraging grounds in King Sound South and Camden Sound Area - Walcott Inlet, Doubtful Bay, Deception Bay and Augustus Island (Kuri Bay), as well as Pender Bay, Carnot & Beagle bays, Maret Island, Biggee Island, Admiralty Gulf & Parry Harbour.
Spotted Bottlenose dolphin (<i>Tursiops aduncus</i>)		b,c,f	b,c,f,m	Calving grounds in Roebuck Bay and Camden Sound Area, Walcott Inlet, Doubtful Bay, Deception Bay and Augustus Island (Kuri Bay). Breeding grounds in King Sound, Yampi Sound and Talbot Bay Fjord area.
Dugong (<i>Dugong dugon</i>)		b,c,f,m,n	b,c,f,m,n	Breeding, calving, nursing and foraging grounds within the Exmouth Gulf and North West Cape regions. Presence may occur throughout the year. Presence in Shark Bay BIAs may be more seasonal, between April and November.
Australian Sea Lion (<i>Neophoca cinerea</i>)			f	Oceanic foraging grounds along west coast and around Abrolhos Islands for resident populations. Presence may occur throughout the year.
Biologically Important Areas				
b	Breeding	m	Migration	
c	Calving	n	Nursing	
d	Distribution	r	Resting	
f	Foraging			

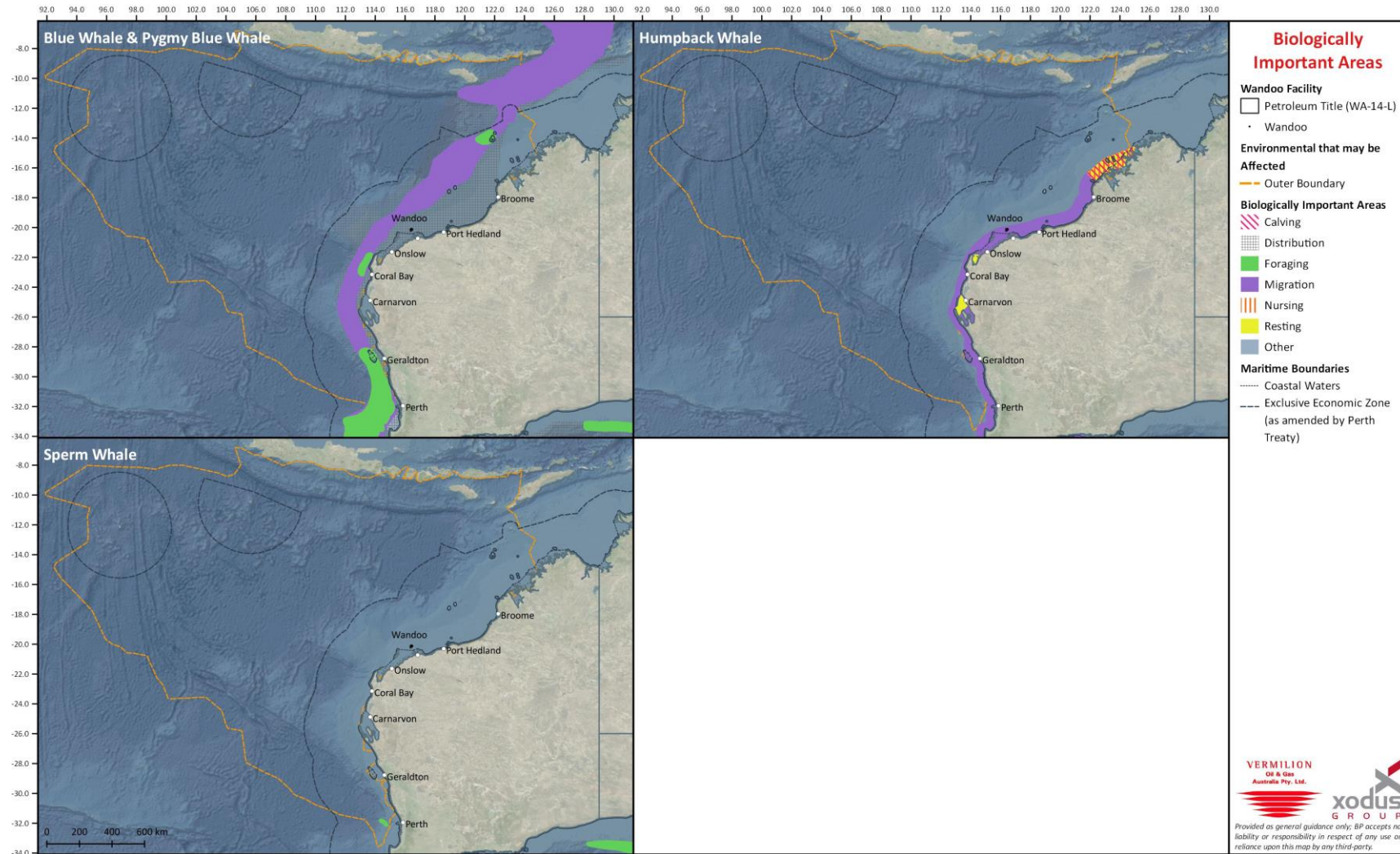

Figure 4-13: Biologically Important Areas for Whale Species (Blue and Pygmy Blue Whale, Humpback Whale, Sperm Whale)

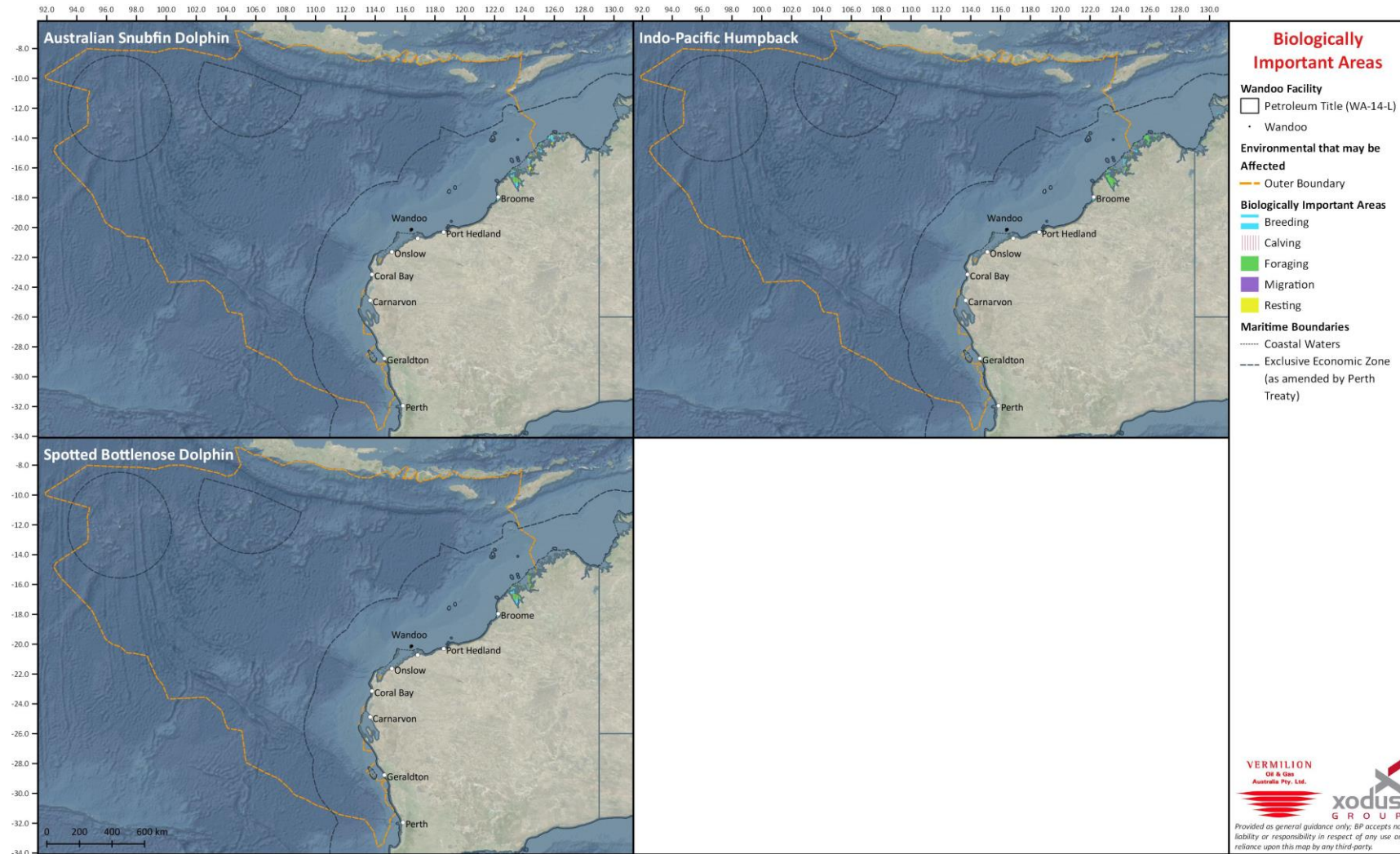

Figure 4-14: Biologically Important Areas for Dolphin Species (Australian Snubfin Dolphin, Indo-Pacific Humpback, Spotted Bottlenose Dolphin)

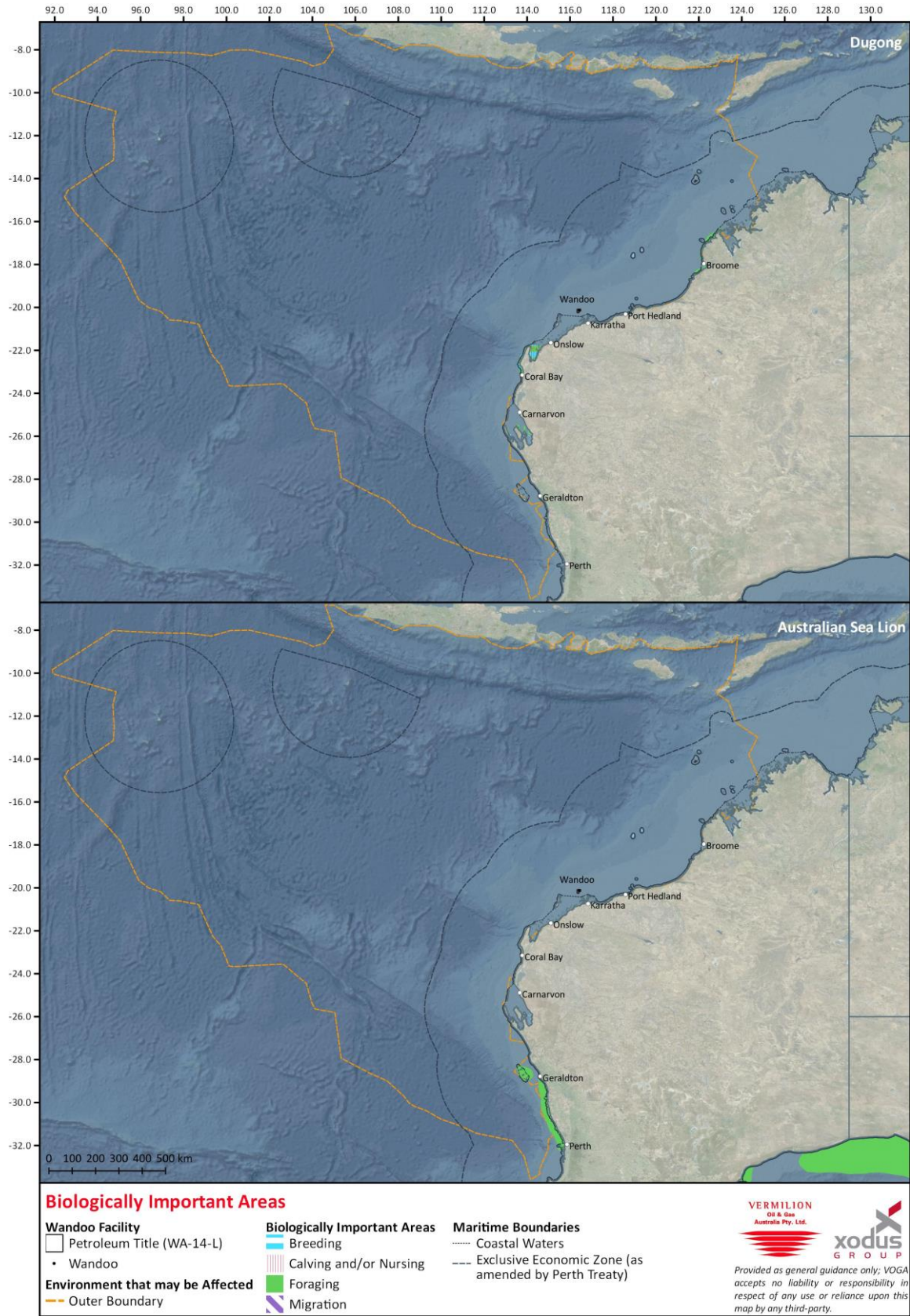

Figure 4-15: Biologically Important Area for Dugong and Pinniped Species

4.4.4.6 *Marine reptiles*

Marine reptiles are expected to occur within the EMBA. Table 4-1 identifies that marine reptiles may be affected within the Hydrocarbon Area, Mixing Zone and Operational Area during the Petroleum Activity. The description below provides sufficient details to assess all impacts and risks to marine reptiles.

There are multiple species (or species habitat) of marine reptile that may occur within the Operational Area, Mixing Zone, Hydrocarbon Area and EMBA (Table 4-10). The presence of most species within the Operational Area is expected to be of a transitory nature only. Some species within the Hydrocarbon Area and EMBA were identified as displaying important behaviour (e.g. nesting, foraging), with some also recognised as having Biologically Important Areas (BIAs) (Table 4-10, Table 4-11).

The Operational Area and Mixing Zone is within an internesting BIA and critical nesting habitat for the flatback turtle (Table 4-11, Figure 4-16). This part of the internesting buffer would be based around nesting locations within the Dampier Archipelago (Table 4-12).

Marine turtles have a highly migratory life history and rely on both marine and terrestrial habitats. North-west WA, including the offshore islands is known for supporting nesting and internesting habitat for turtle species. Nesting and internesting habitat critical to the survival of a species has been identified for genetic stocks present in WA (DoEE, 2017a) (Table 4-12).

There are two species of crocodile that may occur within the EMBA. The salt-water crocodile (*Crocodylus porosus*) and fresh-water crocodile (*Crocodylus johnstoni*). In Western Australia the salt-water crocodile is found in most major river systems of the Kimberley, including the Ord, Patrick, Forrest, Durack, King, Pentecost, Prince Regent, Lawley, Mitchell, Hunter, Roe and Glenelg Rivers. While the fresh-water crocodile occurs along all but the near coastal reaches of the rivers, streams and creeks that flow into the waters off northern Australia between King Sound in the south-western Kimberley, Western Australia



Table 4-10: Marine reptile species or species habitat that may occur within the Project Areas

Scientific Name	Common Name	EPBC Status			Project Areas		
		Threatened Species	Migratory Species	Listed Marine Species	Operational Area & Mixing Zone	Hydrocarbon Area	EMBA
Turtles							
<i>Caretta caretta</i>	Loggerhead Turtle	E	M	✓	KO	BKO	BKO
<i>Chelonia mydas</i>	Green Turtle	V	M	✓	KO	BKO	BKO
<i>Dermochelys coriacea</i>	Leatherback Turtle,	E	M	✓	LO	FKO	FKO
<i>Eretmochelys imbricata</i>	Hawksbill Turtle	V	M	✓	KO	BKO	BKO
<i>Lepidochelys olivacea</i>	Olive Ridley Turtle	E	M	✓		BLO	BLO
<i>Natator depressus</i>	Flatback Turtle	V	M	✓	CKO	BKO	BKO
Seasnakes							
<i>Acalyptophis peronii</i>	Horned Seasnake			✓	MO	MO	KO
<i>Aipysurus apraefrontalis</i>	Short-nosed Seasnake	CE		✓	LO	KO	KO
<i>Aipysurus duboisii</i>	Dubois' Seasnake			✓	MO	MO	MO
<i>Aipysurus eydouxii</i>	Spine-tailed Seasnake			✓	MO	MO	MO
<i>Aipysurus foliosquama</i>	Leaf-scaled Seasnake	CE		✓		KO	KO
<i>Aipysurus fuscus</i>	Dusky Seasnake			✓		KO	KO
<i>Aipysurus laevis</i>	Olive Seasnake			✓	MO	MO	MO
<i>Aipysurus pooleorum</i>	Shark Bay Seasnake			✓		MO	MO
<i>Aipysurus tenuis</i>	Brown-lined Seasnake			✓	MO	MO	MO
<i>Astrotia stokesii</i>	Stokes' Seasnake			✓	MO	MO	MO
<i>Disteira kingii</i>	Spectacled Seasnake			✓	MO	MO	MO

Scientific Name	Common Name	EPBC Status			Project Areas		
		Threatened Species	Migratory Species	Listed Marine Species	Operational Area & Mixing Zone	Hydrocarbon Area	EMBA
<i>Disteira major</i>	Olive-headed Seasnake			✓	MO	MO	MO
<i>Emydocephalus annulatus</i>	Turtle-headed Seasnake			✓	MO	MO	MO
<i>Enhydrina schistosa</i>	Beaked Seasnake			✓		MO	MO
<i>Ephalophis greyi</i>	North-western Mangrove Seasnake			✓	MO	MO	MO
<i>Hydrelaps darwiniensis</i>	Black-ringed Seasnake			✓	MO	MO	MO
<i>Hydrophis coggeri</i>	Slender-necked Seasnake			✓		MO	MO
<i>Hydrophis czeblukovi</i>	Fine-spined Seasnake			✓	MO	MO	MO
<i>Hydrophis elegans</i>	Elegant Seasnake			✓	MO	MO	MO
<i>Hydrophis mcdowelli</i>	Small headed Seasnake			✓		MO	MO
<i>Hydrophis ornatus</i>	Spotted Seasnake			✓	MO	MO	MO
<i>Lapemis hardwickii</i>	Spine-bellied Seasnake			✓		MO	MO
<i>Pelamis platurus</i>	Yellow-bellied Seasnake			✓	MO	MO	MO
Other							
<i>Crocodylus johnstoni</i>	Freshwater Crocodile			✓		LO	MO
<i>Crocodylus porosus</i>	Salt-water Crocodile		M	✓		LO	LO



Scientific Name	Common Name	EPBC Status			Project Areas		
		Threatened Species	Migratory Species	Listed Marine Species	Operational Area & Mixing Zone	Hydrocarbon Area	EMBA
Threatened Species: V Vulnerable E Endangered CE Critically Endangered Migratory Species: M Marine		Type of Presence: MO Species of species habitat may occur within area LO Species or species habitat likely to occur within area KO Species or species habitat known to occur within area FLO Foraging, feeding or related behaviour likely to occur within area FKO Foraging, feeding or related behaviour known to occur within area BKO Breeding known to occur within area CKO Congregation or aggregation known to occur within area					

Table 4-11: Biologically Important Areas for relevant marine turtle species species

Species	BIA Presence			Summary Description of BIA
	Operational Area & Mixing Zone	Hydrocarbon Area	EMBA	
Loggerhead Turtle (<i>Caretta caretta</i>)		f,i,n	f,i,n	Nesting and interesting areas around rookeries, including Lowendal and Montebello islands, Ningaloo Coast, Muiron and Dampier Archipelago. Oceanic foraging area between De Grey River and Bedout Island may be use throughout the year by multiple turtle species.
Green Turtle (<i>Chelonia mydas</i>)		a,b,f,i,ma,m,n	a,b,f,i,ma,m,n	Nesting and interesting areas and rookeries including Barrow and Montebello Islands, North West Cape and Dampier Archipelago. Oceanic foraging grounds around the inshore islands between Cape Preston and Onslow; and De Grey River and Bedout Island.
Hawksbill Turtle (<i>Eretmochelys imbricate</i>)		f,i,ma,m,n	f,i,ma,m,n	Nesting and interesting areas around rookeries, including Montebello and Lowendal Islands, Ningaloo Coast, Thevenard, Barrow and Dampier Archipelago. Oceanic foraging area around the inshore islands between Cape Preston and Onslow; and De Grey River and Bedout Island.



Species	BIA Presence			Summary Description of BIA
	Operational Area & Mixing Zone	Hydrocarbon Area	EMBA	
Flatback Turtle (<i>Natator depressus</i>)	i	a,f,i,ma,m,n	a,f,i,ma,m,n	Nesting and interesting areas around rookeries, including Barrow and Montebello Islands, Thevenard (and other Pilbara inshore islands) and Dampier Archipelago with the potential for presence during summer. Oceanic foraging area around the inshore islands between Cape Preston and Onslow; and De Grey River and Bedout island.
Biologically Important Areas a Aggregation b Basking f Foraging i Interesting ma Mating m Migration n Nesting				

Table 4-12: Habitat critical to the survival of marine turtle species

Species (Genetic Stock)	Nesting locations	Internesting buffer	Nesting season
Flatback turtle (Pilbara)	Montebello Islands, Mundabullangana Beach, Barrow Island, Cemetery Beach, Dampier Archipelago (including Delambre Island and Huay Island), coastal islands from Cape Preston to Locker Island	60 km	October to March
Green turtle (NWS)	Adele Island, Maret Island, Cassini Island, Lacepede Islands, Barrow Island, Montebello Islands (all with sandy beaches), Serrurier Island, Dampier Archipelago, Thevenard Island, North West Cape, Ningaloo coast	20 km	November to March
Hawksbill turtle (WA)	Dampier Archipelago (including Rosemary Island and Delambre Island), Montebello Islands (including Ah Chong Island, South East Island and Trimouille Island), Lowendal Islands (including Varanus Island, Beacon Island and Bridled Island), Sholl Island	20 km	October to February
Loggerhead turtle (WA)	Dirk Hartog Island, Muiron Islands, Gnaraloo Bay, Ningaloo coast	20 km	October to March
Olive ridley turtle	Cape Leveque, Prior Point and Llanggi, Darcy Island, Vulcan Island.	20 km	May to July

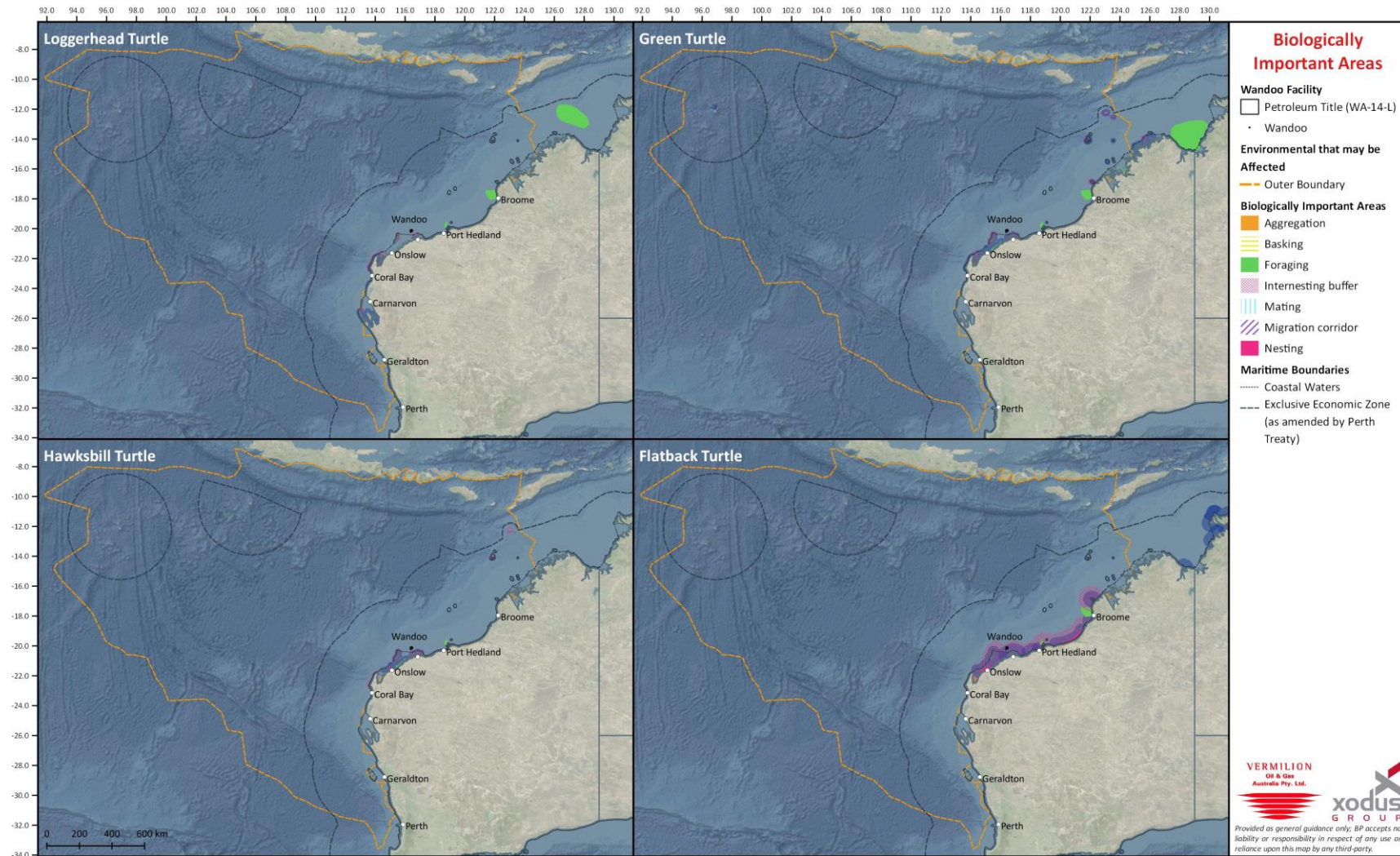

Figure 4-16: Biologically Important Areas for Turtle Species

4.4.4.7 Introduced marine species

A search of the National Introduced Marine Pest Information System identified no known marine pests occurring within the Permit Area.

In the waters of the Dampier Archipelago, six species of macrobiota recognised as non-indigenous are currently recorded (Table 4-13). Many of the introduced species have been recorded as one or a few individuals on one or a few occasions only. Three of these introduced macrobiota (*Balanus amphitrite* Darwin, 1854, *B. cirratus* Darwin, 1854, *B. trigonus* Darwin, 1854) are well known, widely distributed water fouling organisms, within Australian waters (Jones, 2004). *Balanus amphitrite* and *B. cirratus* occur commonly in the intertidal areas throughout the Dampier Archipelago and the adjacent mainland; *B. trigonus* is less widely distributed and is recorded at only two sites within the Archipelago (Jones, 2004). No data is available as to whether the presence of introduced barnacles in the Dampier area has caused any ecological consequences, such as any adverse impacts on native species (Jones, 2004).

In addition to the species listed in Table 4-13, a total of 22 zooplankton species and 45 other planktonic taxa, including crustaceans, molluscs, polychaete worms, arrow worms, sea squirts and coelenterates, have been introduced into the Dampier Archipelago area via Anchor Handling Transport Supply (AHTS) ballast water (Jones, 2004).

Table 4-13: Marine organisms introduced into the Dampier region

Species name	Family	Method of introduction	Possible origin of introduction
<i>Botrylloides leachi</i>	Ascideaceae (Sea squirt)	Unknown	Europe, Atlantic
<i>Balanus amphitrite</i>	Crustacea (Barnacle)	Hull fouling	Cosmopolitan in tropical, subtropical and temperate waters Species is a common fouler throughout WA
<i>Balanus cirratus</i>	Crustacea (Barnacle)	Hull fouling	Indo-west Pacific
<i>Balanus trigonus</i>	Crustacea (Barnacle)	Hull fouling	Cosmopolitan in tropical and warm temperate waters
<i>Megabalanus rosa</i>	Crustacea (Barnacle)	Hull fouling	Japan, China, Taiwan
<i>Megabalanus tintinnabulum</i>	Crustacea (Barnacle)	Hull fouling	Cosmopolitan

Source: Worley Parsons, 2011

4.5 Social and economic environment

4.5.1 Fisheries and aquaculture

Table 4-1 identifies that fisheries and aquaculture may be a relevant receptor to aspects of the activity occurring within the Operational Area, Mixing Zone, Hydrocarbon Area or EMBA during the Petroleum Activity. The description below provides sufficient details to assess all impacts and risks to fisheries and aquaculture.

4.5.1.1 Commonwealth fisheries

Commonwealth fisheries are those managed by the Australian Fisheries Management Authority (AFMA) and typically extend from 3 nm to 200 nm which is the extent of the Australian Fishing Zone (AFZ), in some cases (by agreement with the states and territory) to the low water mark.

There are five Commonwealth managed commercial fisheries with management areas that intersect with the EMBA (Table 4-14). However, not all the fisheries are active within the full extents of the management areas; based on historical fishing effort data (Patterson et al., 2019):

- North West Slope Trawl Fishery (NWSTF) is likely to be active in waters >200 m off the Pilbara and Kimberley coasts (Figure 4-17);
- Southern Bluefin Tuna Fishery (SBTF) is active within waters in the Great Australian Bight and south-eastern Australia; however, the spawning grounds for southern bluefin tuna are located in the north-east Indian Ocean (Figure 4-18);
- Western Deepwater Trawl Fishery (WDTF) is likely to be active in waters >200 m off the Gascoyne coast (Figure 4-19);
- Western Skipjack Tuna Fishery (WSTF), has had no active fishing operations since the 2008-2009 season; and
- Western Tuna and Billfish Fishery (WTBF), is likely to be active in Commonwealth waters off the Gascoyne, Mid West and Southwest coasts (Figure 4-20).

Therefore, based on fishing effort, none of the Commonwealth managed fisheries are expected to be active within, or in the close vicinity of, the Operational Area or Mixing Zone. Additionally, no fishing effort can be expended within the Operational Area due to the safety restriction zone. A summary of the three fisheries that may be active within the EMBA are summarised in Table 4-15.

Table 4-14: Management Areas for Commonwealth Managed Fisheries within the Project Areas

Fishery	Operational Area & Mixing Zone	Hydrocarbon Area	EMBA
North West Slope Trawl Fishery	x	(a)	(a)
Southern Bluefin Tuna Fishery	(n)	(n)	(n)
Western Deepwater Trawl Fishery	x	(n)	(a)
Western Skipjack Tuna Fishery	(n)	(n)	(n)
Western Tuna and Billfish Fishery	(n)	(n)	(a)

(a) = Management area present and active fishing expected; (n) = Management area present and no active fishing expected (x) not present within area

Table 4-15: Commonwealth Managed Fisheries with active fishing effort within the EMBA

Fishery	Boundary	Method	Season	Target Species	Main Landing Ports
NWSTF	200 m isobath to AFZ, Exmouth to Mitchell Plateau	Demersal trawl gear	Year round	Scampi (<i>Metanephrops australiensis</i> , <i>M. boschmai</i> , <i>M. velutinus</i>)	Darwin (NT) Point Samson (WA)
WTBF	In the AFZ and high seas of the Indian Ocean, from Cape York to SA/VIC border	Pelagic longline, minor line and purse seine	Year round	Bigeye tuna (<i>Thunnus obesus</i>) Yellowfin tuna (<i>T. albacares</i>) Broadbill swordfish (<i>Xiphias gladius</i>) Striped marlin (<i>Tetrapturus audux</i>)	Fremantle (WA) Geraldton (WA)
WDTF	200 m isobath to AFZ, Exmouth to Augusta	Demersal trawl gear	1 July – 30 June	Deepwater bugs (<i>Ibacus spp.</i>) Ruby snapper (<i>Etelis carbunculus</i> , <i>Etelis spp.</i>)	Carnarvon (WA) Fremantle (WA)

SFR = Statutory fishing right

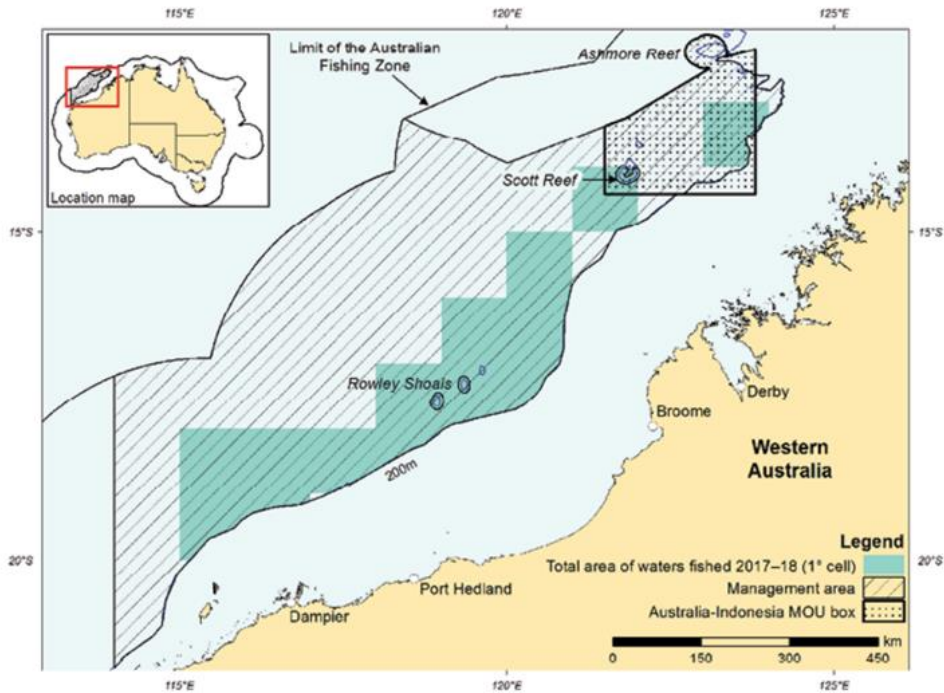

Source: Patterson et al., 2019

Figure 4-17: Management Area for the North West Slope Trawl Fishery, and area fished during 2017–2018

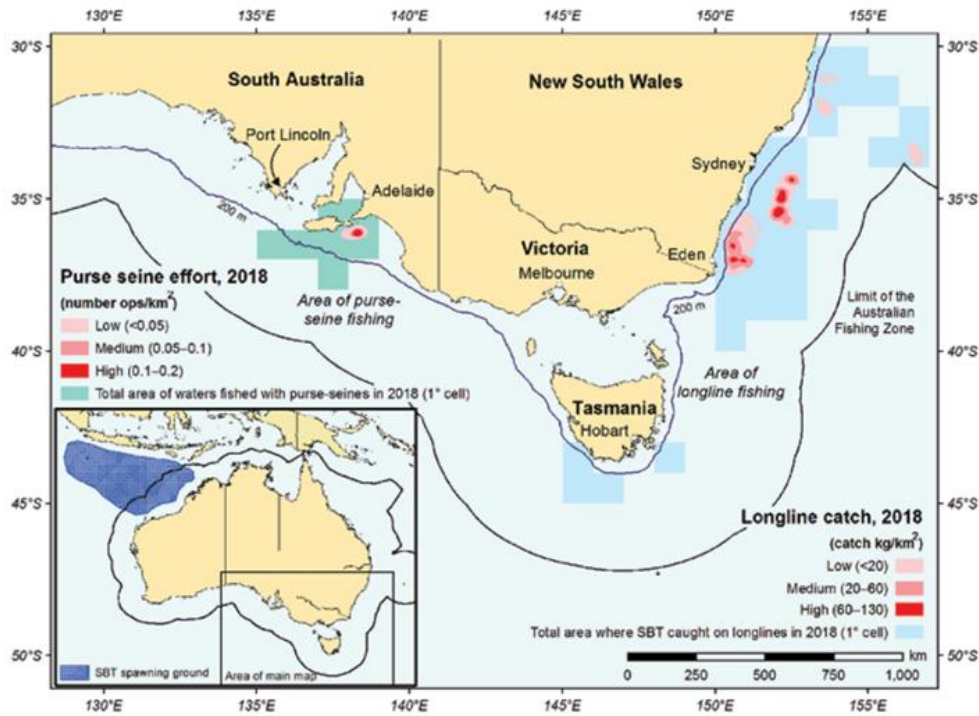

Source: Patterson et al., 2019

Figure 4-18: Management Area for the Southern Bluefin Tuna Fishery, with Indian Ocean spawning ground

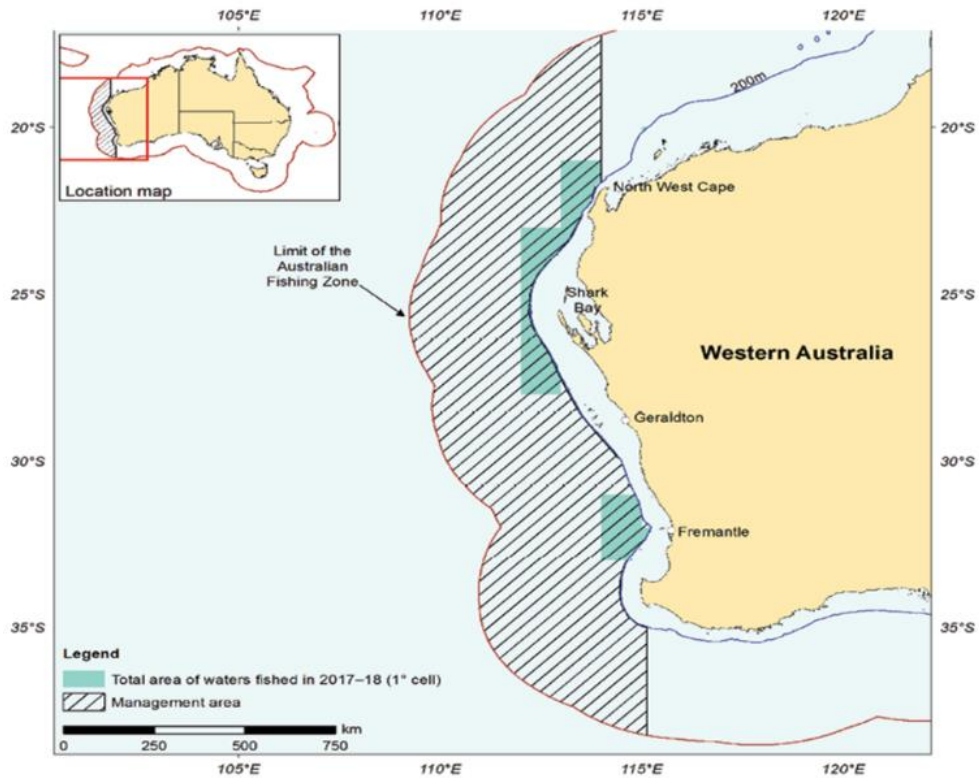

Source: Patterson et al., 2019

Figure 4-19: Management Area for the Western Deepwater Trawl Fishery, and area fished during 2017-2018

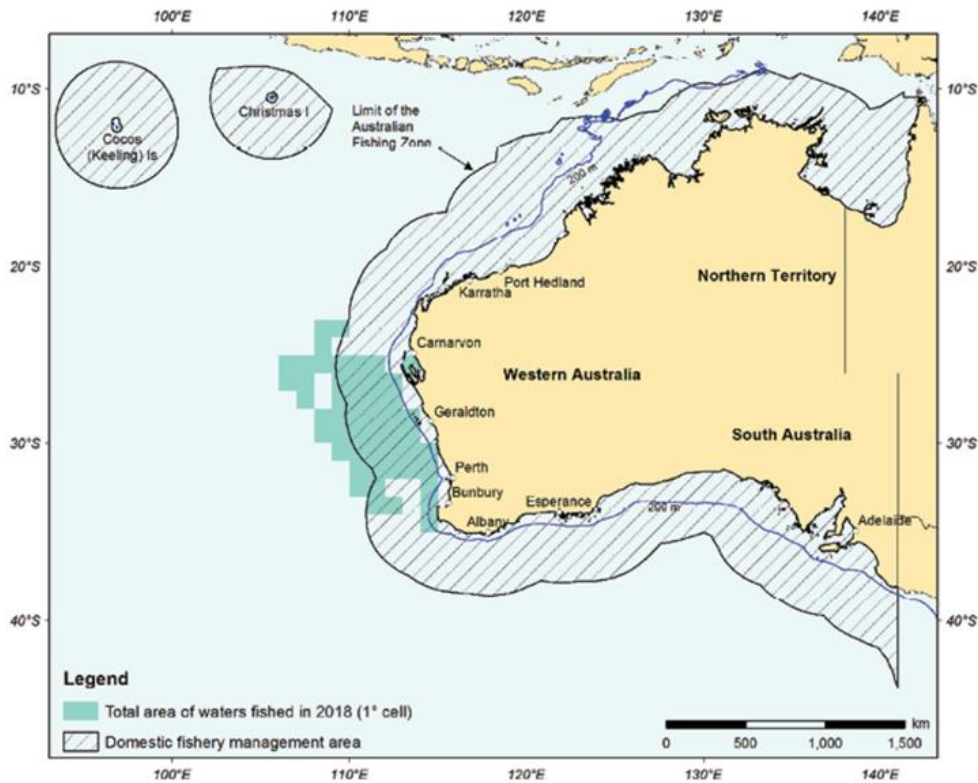

Source: Patterson et al., 2019

Figure 4-20: Management Area for the Western Tuna and Billfish Fishery, and area fished during 2018

4.5.1.2 State fisheries

Western Australian fisheries are managed by the WA Department of Primary Industries and Regional Development (DPIRD). The State fisheries are grouped into bioregions, with the Operational Area and Mixing Zone occurring within the North Coast fishing bioregion. Numerous State-based fisheries have management areas that intersect with the EMBA, including fisheries within the North Coast, Gascoyne and West Coast bioregions; however, not all fisheries are active throughout their entire management areas (Table 4-16).

The FishCube database indicates that five State fisheries may be active within the 60 nm grid block (No. 20160) that intersects with the Operational Area and Mixing Zone:

- Mackerel Managed Fishery (MMF);
- Nickol Bay Prawn Managed Fishery (NBPMF);
- Pilbara Line Fishery (PLF);
- Pilbara Fish Trawl (Interim) Managed Fishery (PFTIMF); and
- Specimen Shell Managed Fishery (SSMF).

However, it is noted that this block from the FishCube database also includes the mainland coastal region, extending from Dampier Archipelago to south of Cape Preston. As such fishing effort within the block is not necessarily indicative of fishing activity within the Operational Area or Mixing Zone.

The SCF, MAFMF and SSMF occur within State waters only, and therefore no activity would occur within the Operational Area for either fishery as it is beyond the fisheries management area boundary. The management boundary for the NBPMP is located to the east of the Operational Area and Mixing Zone, therefore no active fishing within the vicinity of Wandoo would occur.

The MMF focusses around reefs, shoals and headlands. As advised during consultation with WAFIC, fishers operate in water depths by and large from 70 m to as shallow as the boat can go so it is considered that Mackerel fishing (Area 2) may overlap the Operational Area and Mixing Zone.

PLF and PFTIMF may overlap the Operational Area and Mixing Zone. The southern part of the Operational Area and Mixing Zone is within the prohibited fishing area, however the northern part is within an area open to trawling.

Therefore, based on management boundaries and the previous reported fishing effort, minimal fishing activity from the State managed PLF and PFTIMF may occur within or in close proximity to the Operational Area and Mixing Zone.

A summary of State commercial fishery management areas and fishery status (active/not active) for the EMBA, Operational Area, Mixing Zone and Hydrocarbon Area is provided in Table 4-16.

Table 4-16: Management Areas for State Managed Fisheries within the Project Areas

State Managed Fishery	EMBA	Operational Area & Mixing Zone	Hydrocarbon Area
North Coast Bioregion			
Kimberley Mud Crab Fishery	(a)	X	(a)
Pilbara Mud Crab Fishery	(a)	X	(a)
Beche-De-Mer (Sea Cucumber) Fishery	(a)	X	(a)
Pearl Oyster Fishery	(a)	X	(a)
Mackerel Managed Fishery	(a) Areas 1,2,3	(a) Area 2	(a) Areas 1,2,3
Kimberley Gillnet and Barramundi Fishery	(a)	X	(n)
<i>North Coast Demersal Scalefish Fisheries</i>			
Pilbara Fish Trawl (Interim) Managed Fishery	(a)	(a)	(a)
Pilbara Trap Managed Fishery	(a)	(n)	(a)
Pilbara Line Fishery	(a)	(a)	(a)
<i>North Coast Prawn Fisheries</i>			
Onslow Prawn Managed Fishery (OPMF)	(a)	(n)	(a)
Nickol Bay Prawn Managed Fishery (NBPMF)	(a)	(n)	(a)
Broome Prawn Managed Fishery (BPMF)	(a)	X	(a)
Kimberley Prawn Managed Fishery (KPMF)	(a)	X	(a)
Gascoyne Coast Bioregion			
Shark Bay Blue Swimmer Crab Fishery	(a)	X	X
Inner Shark Bay Scalefish Fishery	(a)	X	X
Gascoyne Demersal Scalefish Fishery	(a)	X	(a)
West Coast Deep Sea Crustacean Fishery	(a)	(n)	(a)
Exmouth Gulf Prawn Fishery	(a)	X	(n)

State Managed Fishery	EMBA	Operational Area & Mixing Zone	Hydrocarbon Area
Shark Bay Prawn and Scallop Managed Fisheries	(a)	X	X
West Coast Bioregion			
Octopus Fishery	(a)	X	X
West Coast Demersal Scalefish Fishery	(a)	X	X
West Coast Purse Seine Fishery: <ul style="list-style-type: none"> • Northern Development Zone • Perth Metropolitan. 	(a)	X	X
West Coast Nearshore and Estuarine Finfish	(a)	X	X
Abrolhos Island & Mid West, South West Trawl Fishery	(a)	X	X
Roe's Abalone Fishery	(a)	X	(n)
West Coast Rock Lobster Fishery	(a)	X	(n)
State-wide Bioregion			
The Specimen Shell Managed Fishery (SSMF)	(a)	X	(a)
Marine Aquarium Fish Managed Fishery (MAFMF)	(a)	X	(a)
Pearling and Aquaculture			
Pearling / Aquaculture Leases	(a)	X	(a)

(a) = Management area present and active fishing expected; (n) = Management area present and no active fishing expected (x) not present within area

4.5.1.3 Commercial fish spawning areas

Consultation with the DoF identified that a number of commercial fish species have spawning areas with the EMBA. Their spawning/aggregation times are outlined in (Table 4-17).

Table 4-17: Commercial fish spawning times

Key fish species within EMBA	Spawning/aggregation times
Blacktip shark (<i>Carcharhinus tilstoni</i> and <i>C.limbatus</i>)	November to December
Goldband snapper (<i>Pristipomoides multidens</i>)	January to April
Rankin cod (<i>Epinephelus multiinotatus</i>)	August to October
Red emperor (<i>Lutjanus sebae</i>)	January and March
Pink snapper (<i>Pagrus auratus</i>) (Rare)	May to July
Sandbar shark (<i>Carcharhinus plumbeus</i>)	October to January
Spanish mackerel (<i>Scomberomorous commerson</i>)	August to November

4.5.1.4 Aquaculture

No aquaculture activities take place within the Operational Area or Mixing Zone. There are aquaculture facilities located in near-shore waters of the EMBA, with the closest known facilities to the Operational Area being at the Dampier Archipelago (approximately 45 km from Operational Area) and Montebello Islands (approximately 85 km from the Operational Area).

EMBA and Hydrocarbon Area is managed by the DPIRD and consists primarily of the culturing of hatchery reared and wild caught oysters (*Pinctada maxima*) for pearl production. Pearl aquaculture in the region currently consists of 110 pearl leases ranging from Onslow to Kununurra, including those in the waters around offshore islands such as the Montebellos. Leases typically occur in shallow coastal waters in depths of less than 20 m, and consist of oysters suspended in racks on subsurface ropes. Pearl aquaculture is a high value industry, estimated at \$120 million in 2003 (DoF, 2012).

There is limited finfish culture in the region, with farming of barramundi (*Lates calcarifer*) in sea cages undertaken in Roebuck Bay. Research and development into prawn farming is currently underway, with prawn hatcheries located at Exmouth and Broome (DoF, 2009).

4.5.1.5 Traditional fishing

A Memorandum of Understanding (MoU) between Australia and the Republic of Indonesia has existed since 1974 and allows traditional Indonesian fishers to fish in an area known as the 'MoU Box'. The MoU defines 'traditional fishermen' as fishers who have traditionally taken fish and sedentary organisms in Australian waters using traditional fishing methods and non-motorised sailing vessels. Under the MoU, the taking of protected wildlife including marine turtles, dugongs and clams is prohibited, as is fishing within the Ashmore Reef National Nature Reserve and Cartier Island Marine Reserve. Fishers may access the reefs of Cartier Island, Scott Reef, Seringapatam Reef and Browse Island, and visit Ashmore Reef for access to fresh water and to visit graves (DEWHA, 2008). The peak fishing season is between August and October with fishers departing the region at the onset of the northwest monsoon season.

In 1983 Australia declared a marine protected area around Ashmore Island, and in 2000 around Cartier Island.

The MOU represents an area of 200nm within the AFZ encompassing Scott Reef and associated reefs including Seringapatam Reef, Browse Island, Ashmore Reef, Cartier Reef and various banks.

4.5.1.6 Recreational fisheries

Recreational fishing within the EMBA is managed by the DPIRD and mainly occurs at nearshore locations such as the Dampier Archipelago and Montebello Islands and State waters adjacent to populated coastal areas (DoF, 2011).

Within the EMBA the North Coast bioregion is experiencing significant recreational fishing growth, with a distinct seasonal peak in winter when the local population increases significantly by way of tourists visiting the Exmouth/Onslow area and Dampier Archipelago (Fletcher and Santoro, 2011).

Increased recreational fishing has also been attributed to those involved in the construction or operation of developments within the region.

At a distance of approximately 35 km from the Dampier Archipelago and 85 km from the Montebello Islands, the Operational Area or Mixing Zone are unlikely to be visited by recreational fishers.

Creek systems, mangroves and rivers, and ocean beaches provide shore and small boat fishing for a variety of species including barramundi, tropical emperors, mangrove jack, trevallies, sooty grunter, threadfin, mud crabs and cods. Offshore islands, coral reefs and continental shelf provide species of major recreational interest including saddletail snapper, red emperor, cods, coral and

coronation trout, sharks, trevally, tuskfish, tunas, mackerels and billfish. Because of the high tidal range, most angling activity is boat-based, with beach fishing limited to periods of flood tides and high water. Boat ownership in Dampier is recognised as the highest in Australia (Shire of Roebourne, 2013).

The waters of Ningaloo Reef and the Muiron islands support an abundance of prized table fish, and the reef is considered an important fishing location. The fringing reef provides sheltered waters that are accessible to small recreational vessels and extensive opportunities exist for beach fishing. Recreational fishing is largely concentrated around major settlements at Coral Bay and Exmouth and boat ramps at Tantabiddi and Bundegi (Sumner et al., 2002).

4.5.2 Commercial shipping

Table 4-1 identifies that commercial shipping may be a relevant receptor to aspects of the activity occurring within the Operational Area, Mixing Zone, Hydrocarbon Area or EMBA during the Petroleum Activity. The description below provides sufficient details to assess all impacts and risks to commercial shipping.

Significant commercial shipping activity occurs within the EMBA, the majority of which is associated with the WA oil and gas and mining industries.

AMSA has established a network of shipping fairways for the North West Shelf with the aim to reduce the risk of collision between transiting vessels and offshore infrastructure (AMSA, 2012). The fairways are intended to direct large vessels such as bulk carriers and LNG ships trading to the major ports into pre-defined routes to keep them clear of existing and planned offshore infrastructure.

The Operational Area and Mixing Zone are approximately 25 km from the northbound shipping fairway from Dampier (Figure 4-21). Major shipping routes in the EMBA include entry to the ports of Port Hedland and Dampier.

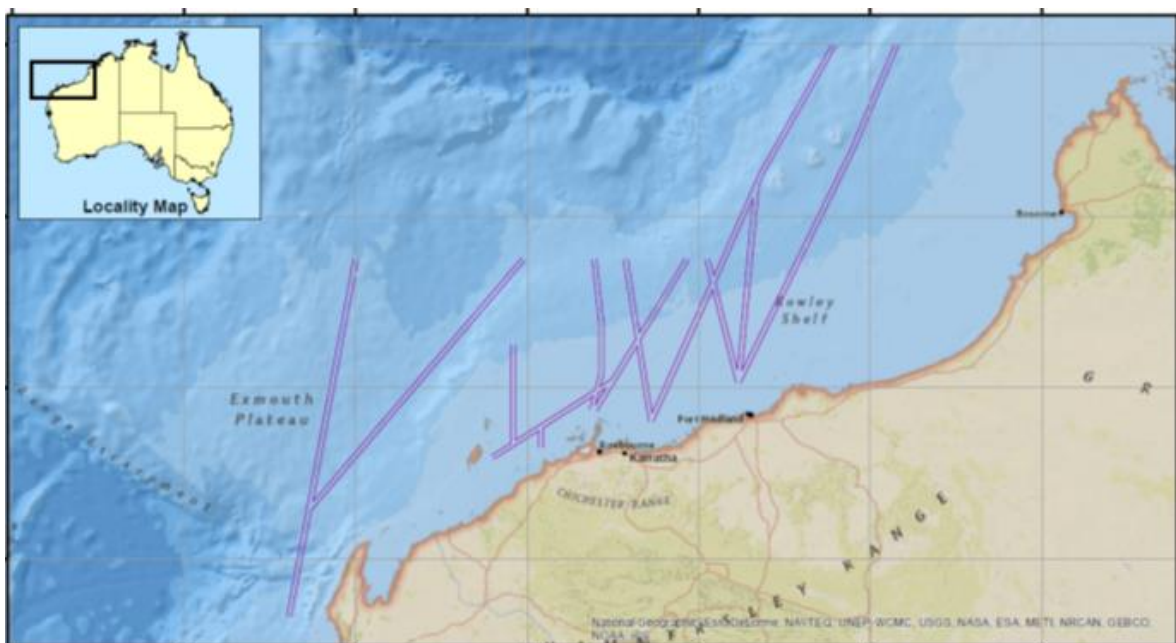

Figure 4-21: North West Shelf Shipping Fairways

4.5.3 Defence

Table 4-1 identifies that defence may be a relevant receptor to aspects of the activity occurring within the Hydrocarbon Area or EMBA during the Petroleum Activity. There is no known defence activity within the Operational Area or Mixing Zone. The description below provides sufficient details to assess all impacts and risks to commercial shipping.

The EMBA encompasses the military installations near Exmouth, including a naval communication station and a pier facility. The Department of Defence has several offshore training areas including the North West Exercise Area, North Australia Exercise Area (approximately 1,450km north of the Operational Area) and Learmonth Air Weapons Range (approximately 320km north of the Operational Area) in the EMBA. These areas are used for Defence Force training operations, including live firing.

4.5.4 Other users

Table 4-1 identifies that other users may be a relevant receptor to aspects of the activity occurring within the Hydrocarbon Area or EMBA during the Petroleum Activity. No significant use of the Operational Area or Mixing Zone by other users has been identified. The description below provides sufficient details to assess all impacts and risks to commercial shipping.

4.5.4.1 Oil and gas industry

The petroleum exploration and production industry is a significant stakeholder in the region. Petroleum companies have been undertaking exploration and production activities on the NWS for a number of years.

Petroleum activities within the vicinity of the Wandoo facility include Santos Reindeer platform (~17km northwest) and Jadestone Energy's Stag platform and Dampier Spirit FSO (~24km southwest). There are also several submerged pipelines associated with petroleum fields and facilities with onshore processing hubs (e.g. the TL1 and TL2 export pipelines from the North Rankin Complex to the Karratha Gas Plant).

4.5.4.2 Tourism and recreation

Tourism plays a significant role in the region. Water-based tourism activities undertaken across the NWS include:

- whale watching;
- recreational boating and fishing;
- charter fishing;
- snorkelling/diving; and
- surfing.

Popular land-based activities include bushwalking, camping, bird watching and four-wheel driving.

Major tourism precincts within the EMBA include the Ningaloo Coast, the Exmouth Gulf and Broome. Ningaloo is a significant area for nature-based tourism, estimated to be worth approximately \$127 million. A significant proportion of tourism in the Ningaloo region is generated from the Whale Shark watching industry (March to May). Nature-based tourism

services around Ningaloo also operate all-year round. Ningaloo Reef is closely adjoined by Cape Range National Park, a significant area for land-based tourism such as bushwalking.

Tourism is one of the main economic activities on Christmas Island centred on nature-based activity and the Island's cultural heritage. Fish, corals, rock formations and caves provide snorkelling and diving opportunities. Other popular activities include fishing, bird watching and bushwalking. The migration of large numbers of red crab occurs between October and January each year; whale sharks may also be seen at this time. The tourism industry on Christmas Island and the Cocos (Keeling) Islands is limited as flights are expensive and there is limited tourism promotion and marketing.

Tourism on the Cocos Islands is centred round nature-based activities such as wind and kite surfing, diving, snorkelling and fishing.

4.6 Values and sensitivities

Table 4-1 identifies that values and sensitivities may be a relevant receptor to aspects of the activity occurring within the Operational Area, Mixing Zone, Hydrocarbon Area or EMBA during the Petroleum Activity. The description below provides sufficient details to assess all impacts and risks to values and sensitivities.

4.6.1 World Heritage Areas

There are three World Heritage Areas (WHAs) in the EMBA:

- Ningaloo Coast WHA.
- Shark Bay WHA.
- Komodo National Park

The Ningaloo Coast was inscribed into the World Heritage List in 2011 under criteria (vii) and (x) of the UNESCO Operational Guidelines for the Implementation of the World Heritage Convention (DSEWPaC, 2011). The listing recognises the outstanding universal values of the Ningaloo Coast, particularly the following:

Exceptional natural beauty:

- Aesthetically striking coastal and terrestrial environment of the Ningaloo Reef adjacent to the Cape Range; and
- The lush and colourful underwater scenery and its contrast with the arid and rugged land.

Containing the most important and significant natural habitats for in-situ conservation of biological diversity:

- One of the largest annual aggregation of whale sharks in the world;
- Important aggregations of other fish species and marine mammals;
- High marine diversity, including an unusual diversity of marine turtle species;
- Rare and diverse subterranean creatures; and
- Diversity of reptiles and vascular plants in the drylands.

The Ningaloo Coast WHA has a high diversity of marine habitats, including coastal mangrove systems, lagoons, reef, open ocean, continental slope and the continental shelf and includes both the Commonwealth and State marine parks (CALM and MPRA, 2005). The most dominant habitat of the Ningaloo WHA is the Ningaloo Reef, the largest fringing reef in Australia. The Ningaloo Reef supports both tropical and temperate species of marine fauna and flora, and more than 300 species of coral (CALM and MPRA, 2005).

The Ningaloo Coast WHA is a very important nesting habitat for four species of marine turtle that are found in WA. The North West Cape and Muiron Islands are major nesting sites for loggerhead turtles, and North West Cape is also a major nesting habitat for hawksbill and green turtles. The Muiron Islands are also minor nesting sites for flatback and hawksbill turtles.

Each year, the largest congregation of whale sharks anywhere in the world takes place off the coast of the Ningaloo WHA (DEWHA, 2008). It is estimated that between 300 and 500 whale sharks visit the area each year between March and June, coinciding with mass coral spawning events. Several species of whales are also known to pass through or congregate in the area, (Jenner *et al.*, 2001) and the Muiron Islands provide suitable seagrass habitat for the dugong.

Shark Bay has the largest and richest seagrass beds in the world, covering an area of 4800km², supporting an important dugong population. In addition, Shark Bay hosts some of the oldest forms of life on earth – stromatolites – which are colonies of algae that form hard dome-shaped deposits (UNESCO, 2013).

Shark Bay WHA covers an area of approximately 10,000 km² and was inscribed into the World Heritage list in 1991 for all four natural values (vii, viii, ix and x), summarised as follows (DSEWPaC, 2008):

- (vii) Outstanding example representing the major stages of the earth's evolutionary history – such as containing divers and abundant stromatolites/microbial mats at Hamelin Pool.
- (viii) Outstanding example representing significant ongoing geological processes, biological evolution and man's interaction with his natural environment, e.g. the high species diversity of and richness of seagrasses and containing one of the most extensive seagrass meadows in the world.
- (ix) Contain unique, rare or superlative natural phenomena, formation or features of exceptional beauty – such as the abundance of marine fauna (dugongs, dolphins, sharks, rays, turtles and fish).
- (x) Contain the most important and significant habitats where threatened species of plants and animals of outstanding universal value from the point of view of science and conservation still survive – such as marine mammals including the threatened species of humpback whales (*Megaptera noveangliae*), green turtle (*Chelonia mydas*) and loggerhead turtles (*Caretta caretta*).

The World Heritage criteria are periodically revised and the criteria against which the property was listed in 1991 are not necessarily identical with the current criteria.

A Statement of Outstanding Universal Value (SOUV) is the official statement adopted by the World Heritage Committee, normally at the time of inscription of a property on the World Heritage List. In the case of properties/sites that were inscribed before the requirement for a SOUV was introduced into the World Heritage Convention in 2005, a Retrospective SOUV is

required. A Retrospective SOUV for Shark Bay WHA was adopted by the World Heritage Committee in June 2013 (UNESCO, 2013).

The Komodo National Park was inscribed into the World Heritage list in 1991 under criteria (vii) and (x) of the UNESCO Operational Guidelines for the Implementation of the World Heritage Convention (UNESCO, 2014). The National Park covers 219,322 hectares and consists of three larger islands Komodo, Padar and Rinca, and 26 smaller ones. The majority of the WHA is marine.

The listing recognises the outstanding universal values of the Komodo National Park, particularly the following:

The 'Komodo dragon':

- The volcanic islands are inhabited by 5700 giant lizards ('Komodo dragons'); and
- They exist nowhere else in the world and are of great interest to scientists studying the theory of evolution.

Exceptional natural beauty:

- Landscape of contrasts between starkly rugged hillsides of dry savannah, pockets of thorny green vegetation, brilliant white sandy beaches and blue waters surging over coral, unquestionably one of the most dramatic landscapes in all of Indonesia; and
- An irregular coastline characterised by bays, beaches and inlets separated by headlands, often with sheer cliffs falling vertically into the surrounding seas which are reported to be among the most productive in the world.
- The marine fauna and flora are generally the same as that found throughout the Indo Pacific area, though species richness is very high, notable marine mammals include blue whale and sperm whale as well as 10 species of dolphin, dugong, and five species of sea turtles (UNESCO, 2014).

4.6.2 National Heritage Properties

The National Heritage List has been established under the EPBC Act to list places of outstanding heritage significance to Australia. The National Heritage List is compiled and maintained by the DAWE.

Five places within the EMBA are listed on the National Heritage list (Table 4-18). Three of these also occur within the Hydrocarbon Area; there are no sites of National Heritage Properties in the Operational Area or Mixing Zone. Table 4-19 provides a summary of each of these heritage features.

Table 4-18 National Heritage Properties within the Project Areas

Key Ecological Feature	Operational Area & Mixing Zone	Hydrocarbon Area	EMBA
Dampier Archipelago (including Burrup Peninsula)		X	X
HMAS Sydney II and HSK Kormoran Shipwreck Sites			X
Shark Bay, Western Australia			X
The Ningaloo Coast		X	X
The West Kimberley		X	X

X= present within area

Table 4-19: Description of National Heritage Properties within the EMBA

Site	Listing	Description
Natural		
Shark Bay, Western Australia	Natural Listed Place	Shark Bay was included on the National Heritage List due to its abundant marine flora and fauna (see also Section 4.6.1). Five mammals listed as endangered are found here, as well as 35% of Australian bird species. It is the meeting point of three major climatic regions.
The Ningaloo Coast	Natural Listed Place	The Ningaloo Coast was included on the National Heritage List due to its extraordinary natural qualities and Indigenous significance (see also Section 4.6.1).
The West Kimberley	Natural Listed Place	The West Kimberley is important due to its vast area of relatively undisturbed landscape with high biological richness and evolutionary history.
Indigenous		
Dampier Archipelago (including Burrup Peninsula)	Indigenous Listed Place	The Dampier Archipelago (including Burrup Peninsula) was included on the National Heritage List due to the Indigenous rock engravings found there, including finely executed images of a wide range of terrestrial, avian and marine fauna that are unique and characteristic of the region.
Historic		
HMAS Sydney II and HSK Kormoran Shipwreck Sites	Historic Listed Place	HMAS Sydney II and KSG Kormoran are located 22km apart, 290km west-south-west of Carnarvon. The infamous HMAS Sydney II sank after a battle with KSK Kormoran in November 1941.

4.6.3 Commonwealth Heritage Places

The Commonwealth Heritage List, also established under the EPBC Act, comprises natural, indigenous and historic heritage places which are either entirely within a Commonwealth area, or outside the Australian jurisdiction and owned or leased by the Commonwealth or a Commonwealth Authority. A Commonwealth Heritage Place might also be on the National Heritage List or the World Heritage List.

Eleven Commonwealth Heritage Places (with a marine/coastal interface) were identified within the EMBA (Table 4-20). Three of these also occur within the Hydrocarbon Area; there are no sites of Commonwealth Heritage Places in the Operational Area or Mixing Zone. Table 4-21 provides a summary of each of these heritage features.

Table 4-20 Commonwealth Heritage Places within the Project Areas

Key Ecological Feature	Operational Area & Mixing Zone	Hydrocarbon Area	EMBA
Ashmore Reef National Nature Reserve			X
Christmas Island Nature Areas			X
HMAS Sydney II and HSK Korman Shipwreck Sites			X
Home Island Foreshore			X
Learmonth Air Weapons Range Facility			X
Mermaid Reef Rowley Shoals		X	X

Key Ecological Feature	Operational Area & Mixing Zone	Hydrocarbon Area	EMBA
Ningaloo Marine Area- Commonwealth Waters		X	X
North Keeling Island			X
Scott Reef and Surrounds- Commonwealth Area		X	X
Six-Inch Guns			X
Slipway and Tank			X

X= present within area

Table 4-21: Description of Commonwelath Heritage Places within the EMBA

Site	Listing	Description
Natural		
Ashmore Reef National Nature Reserve	Natural Listed Place	Ashmore Reef has major significance as a staging point for wading birds migrating between Australia and the northern hemisphere, including forty-three species listed on one or both of the China Australia Migratory Bird Agreement and the Japan Australia Migratory Bird Agreement. Ashmore Reef supports extremely high concentrations of breeding seabirds and exhibits a higher diversity of marine habitats compared with other North-West Shelf reefs (DAWE, 2020a)
Christmas Island Nature Areas	Natural Listed Place	Christmas Island is a tectonically uplifted coral atoll with its characteristic steep series of rainforest-covered terraces and sheer limestone cliffs. The island's geological formations are significant in illustrating the evolution of the Christmas Rise due to tectonic and volcanic action and the collision of the Asian and Australian plates. The evolutionary significance of Christmas Island is demonstrated both by its high level of endemism and by its unique assemblage of plant and animal species. The dominance of the land crabs is a striking feature of the island's fauna. The island has thirteen of the twenty species known worldwide and one of the highest land crab densities known in the Indian Ocean. The land crabs of Christmas Island are remarkable for their variety and numbers and for the role they play in the ecology of the rainforest. Christmas Island provides habitat for four nationally endangered and six nationally vulnerable fauna species, and one nationally vulnerable plant species. (DAWE, 2020b)
Learmonth Air Weapons Range Facility	Natural Listed Place	The geomorphology of Cape Range, of which the Learmonth Range Facility is a part of, is of considerable importance in documenting sea level and landform changes. The coastal plain of Cape Range contains a network of subterranean waterways, comprising caverns and fissures in the limestone beneath the coastal plain. Of these, Bundera Sinkhole, found within the Learmonth Range Facility, is the only deep anchialine system known in Australia, and is the only continental anchialine system known in the southern hemisphere (DAWE, 2020c).

Site	Listing	Description
Mermaid Reef Rowley Shoals	Natural Listed Place	Mermaid Reef is characterised by environmental conditions which are rare for shelf edge reefs and are known only from the Rowley Shoals in Western Australia (WA) and include clear, deep oceanic water and large tidal ranges. Species of conservation significance recorded at the place include the nationally vulnerable green turtle (<i>Chelonia mydas</i>). The Rowley Shoals provides habitat for species which have not previously been recorded in (WA) including: 216 species of fish; thirty-nine species of molluscs; and seven species of echinoderms. It is regionally important for the diversity of its fauna which includes; corals (184 species in fifty-two genera); molluscs (260 species); echinoderms (ninety species); and fish (485 species). (DAWE, 2020d)
Ningaloo Marine Area- Commonwealth Waters	Natural Listed Place	Whale sharks (<i>Rhincodon typus</i>) congregate in the Ningaloo Marine Area following the mass coral spawning each autumn in the adjacent Ningaloo Reef (State waters). The place is an important feeding area for the shark and one of the few places in the world where they are known to congregate regularly in significant numbers. Ningaloo Marine Area is part of the annual migration route for the Commonwealth endangered humpback whale. They migrate northward to Kimberley (WA) breeding grounds in winter (June-August) and southward to Antarctic feeding grounds in summer (August-November). Other Commonwealth listed threatened species found in the place are the endangered blue whale, southern right whale (<i>Eubalena australias</i>), loggerhead turtle and southern giant petrel (<i>Macronectes giganteus</i>); the vulnerable fin whale (<i>Balaenoptera physalis</i>), sei whale (<i>Balaenoptera borealis</i>), green turtle, hawksbill turtle, flatback turtle, soft-plumaged petrel (<i>Pterodroma mollis</i>), great white shark (<i>Charcharodon Carcharias</i>) and grey nurse shark (<i>Carcharias Taurus</i>). Other significant species include the dugong, spinner dolphin (<i>Stenella longirostris</i>), yellow-nosed albatross (<i>Diomedea chlororhynchos</i>) and osprey (<i>Pandion haliaetus</i>). The place is on the migratory route of many trans-equatorial wader bird species. It provides valuable feeding grounds for many migratory seabirds. This includes eleven species protected under the JAMBA and/or CAMBA Treaties. (DAWE, 2020e)
North Keeling Island	Natural Listed Place	North Keeling Island is significant as one of the few remaining pristine tropical islands in the Indian Ocean region. The Island has rare ecosystems and a high significance for Indian Ocean sea birds, playing a vital part in the stability of the Indian Ocean sea bird biota. The Island is significant to studies of island biogeography because of its evolution in isolation. The Island is of very high importance to Indian Island sea bird populations, supporting the most diverse populations in this ocean. Nineteen species are found on the Island, twelve of which breed here. This is significant as the Island is the only rookery within 900km. The Island also supports a diverse land crab population with six species occurring here. (DAWE, 2020f)

Site	Listing	Description
Scott Reef and Surrounds- Commonwealth Area	Natural Listed Place	Scott Reef is a significant component of a disjunct chain of shelf edge reefs separated from Indonesia by the Timor Trough. The place is regionally significant both because of its high representation of species not found in coastal waters off Western Australia and for the unusual nature of its fauna which has affinities with the oceanic reef habitats of the Indo-West Pacific as well as the reefs of the Indonesian region. Scott and Seringapatam Reefs together are regionally important for the diversity of their fauna which includes corals (224 species in 56 genera); molluscs (279 species); decapod CRUSTACEA (56 species); echinoderms (117 species); and fish (558 species). (DAWE, 2020g)
Historic		
HMAS Sydney II and HSK Kormoran Shipwreck Sites	Historic Listed Place	The naval battle fought between the Australian warship HMAS Sydney II and the German commerce raider HSK Kormoran off the Western Australian coast during World War II was a defining event in Australia's cultural history. HMAS Sydney II was Australia's most famous warship of the time and this battle has forever linked the stories of these warships to each other. The tragic loss of HMAS Sydney II along with its entire crew of 645 following the battle with HSK Kormoran, remains as Australia's worst naval disaster and sent shockwaves throughout the Australian community in November 1941. (DAWE, 2020i)
Home Island Foreshore	Historic Listed Place	The Home Island Foreshore and avenue of trees is significant for its association with the settlement of the kampong and the development of Home Island. It is also significant for its contribution to Cocos Malay settlement life providing a shady avenue linking the jetty area to Lot 14. The foreshore strip provides a buffer between the lagoon and kampong housing as well as a place to store boats and to view lagoon activities. (DAWE, 2020j)
Six-Inch Guns	Historic Listed Place	The Six-Inch Guns, circa 1941, demonstrate the Cocos (Keeling) Islands' important strategic location in the Indian Ocean during the Second World War. The Six-Inch Guns are surviving evidence of the armed forces occupation and impact of the Second World War on the Cocos (Keeling) Islands and are the only remnant of the period when the Ceylonese Army was stationed on Horsburgh Island. (DAWE, 2020k)
Slipway and Tank	Historic Listed Place	The Slipway and Tank are significant as remaining evidence of the Islands' role in servicing flying boats during World War II and were possibly also associated with the servicing of boats during the time of the air and sea rescue station. These functions signify the important strategic location of the Cocos (Keeling) Islands in the Indian Ocean, and also indicate the former use and occupancy of Direction Island. (DAWE, 2020l)

4.6.4 Underwater Cultural Heritage

Australia's underwater cultural heritage is protected under the Commonwealth *Underwater Cultural Heritage Act 2019*; this legislation protects shipwrecks, sunken aircraft and other types of underwater heritage.

There are no known underwater heritage features within the Operational Area or Mixing Zone, but an extensive number within the EMBA and Hydrocarbon Area. A regional overview is provided in Table 4-22, however there is a low probability that a spill will result in any significant impact to shipwrecks within the EMBA. There is also a single record of a sunken aircraft (offshore from 80

Mile Beach) and in situ artefact (offshore of Point Samson) within the EMBA and Hydrocarbon Area.

Table 4-22: Regional overview of the shipwrecks within the EMBA

Location	No. of shipwrecks	Approximately distance to Wandoo Field
Broome	150	NE ~650km
Browse Island	9	NE ~1000km
Dampier	86	SE ~35km
Eighty Mile Beach	67	E ~400km
Exmouth Gulf	28	SW ~270km
King Sound	27	NE ~800km
Lacepedes	46	NE ~700km
Montebello	10	SW ~100km
North West Cape	10	SW ~300km
Onslow	16	SW ~200km
Port Hedland	83	E ~200km
Abrolhos	52	SW ~920km
Geraldton	86	S ~960km
Dongara	26	S ~1020km
Jurien Bay	44	S ~1120km

4.6.5 Commonwealth Protected Areas

4.6.5.1 Australian Marine Parks

Australian Marine Parks (AMPs) occur within Commonwealth waters and have been proclaimed as Commonwealth reserves under the EPBC Act in 2007 and 2013. Within the EMBA, 17 AMPs are present; 13 within the North-west Marine Region, and four within the South-west Marine Region (Table 4-23, Figure 4-22). The closest AMPs to the Operational Area are the Montebello Marine Park (approximately 35 km west) and Dampier Marine Park (approximately 38 km southeast).

Table 4-23: Australian Marine Parks within the Project Areas

Australian Marine Park	Operational Area & Mixing Zone	Hydrocarbon Area	EMBA
North-west Marine Region			
Kimberley		X	X
Ashmore Reef			X
Cartier Island			X
Argo-Rowley Terrace		X	X
Mermaid Reef		X	X
Roebuck		X	X
Eighty Mile Beach		X	X
Dampier		X	X
Montebello		X	X

Australian Marine Park	Operational Area & Mixing Zone	Hydrocarbon Area	EMBA
Ningaloo		X	X
Gascoyne		X	X
Carnarvon Canyon		X	X
Shark Bay		X	X
South-west Marine Region			
Abrolhos		X	X
Jurien			X
Two Rocks			X
Perth Canyon			X

X= present within area

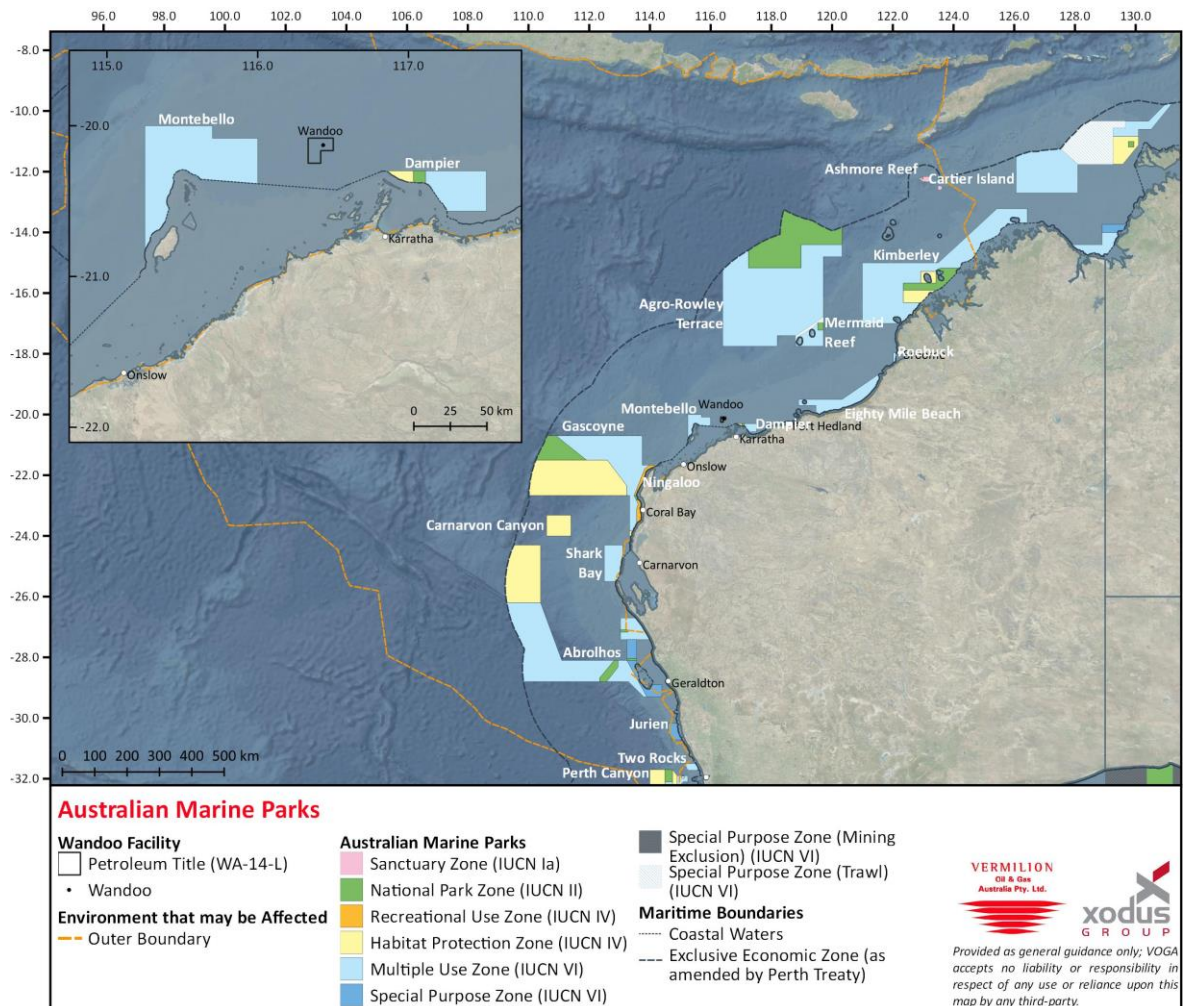

Figure 4-22: Australian Marine Parks

The following types of values have been identified for each of the marine parks within the respective management plans (DNP, 2018a, 2018b), and are summarised in Table 4-24:

- natural values, as habitats, species and ecological communities, and the processes that support their connectivity, productivity and function
- cultural values, as living and cultural heritage recognising Indigenous beliefs, practices and obligations for country, places of cultural significance and cultural heritage sites
- heritage values, as non-Indigenous heritage that has aesthetic, historic, scientific or social significance
- socio-economic values, as the benefits for people, businesses and/or the economy.

Table 4-24: Significance and values of Australian Marine Parks

North-West Marine Region
Kimberley Marine Park
<p>The Kimberley Marine Park is located approx. 100 km north of Broome, extending from the Lacepede Islands to the Holothuria Banks offshore from Cape Bougainville. The Marine Park is adjacent to the State Lalangarram/Camden Sound Marine Park and the North Kimberley Marine Park. The Marine Park covers an area of 74,469km² and water depths from <15 m to 800 m. Marine Park includes three zones: National Park Zone (II), Habitat Protection Zone (IV) and Multiple Use Zone (VI).</p> <p>Statement of significance</p> <p>The Kimberley Marine Park is significant because it includes habitats, species and ecological communities associated with the Northwest Shelf Province, Northwest Shelf Transition and Timor Province, and includes two KEFs. The Marine Park provides connectivity between deeper offshore waters, and the inshore waters of the adjacent State North Kimberley and Lalang-garram/Camden Sound Marine Parks.</p> <p>Natural values</p> <p>Examples of ecosystems representative of the:</p> <p>Northwest Shelf Province, an area influenced by strong tides, cyclonic storms, long-period swells and internal tides. The region includes diverse benthic and pelagic fish communities, and an ancient coastline thought to be an important seafloor feature and migratory pathway for humpback whales.</p> <p>Northwest Shelf Transition, this area straddles the North-west and North Marine Regions and includes shelf break, continental slope, and the majority of the Argo Abyssal Plain and is subject to a high incidence of cyclones. Benthic biological communities in the deeper parts of the region have not been extensively studied, although high levels of species diversity and endemism occur among demersal fish communities on the continental slope.</p> <p>Timor Province, an area dominated by warm, nutrient-poor waters. The reefs and islands of the region are regarded as biodiversity hotspots; endemism in demersal fish communities of the continental slope is high and two distinct communities have been identified on the upper and mid slopes.</p> <p>Contains two KEFs: ancient coastline at the 125-m depth contour, and the continental slope demersal fish communities.</p> <p>Supports a range of species, including species listed as threatened, migratory, marine or cetacean under the EPBC Act.</p> <p>BIAs within the Marine Park include breeding and foraging habitat for seabirds, internesting and nesting habitat for marine turtles, breeding, calving and foraging habitat for inshore dolphins, calving, migratory pathway and nursing habitat for humpback whales, migratory pathway for pygmy blue whales, foraging habitat for dugong and foraging habitat for whale sharks.</p> <p>Cultural values</p>

North-West Marine Region

Sea country is valued for Indigenous cultural identity, health and wellbeing. The Wunambal Gaambera, Dambimangari, Mayala, Bardi Jawi and the Nyul Nyul people have responsibilities for sea country in the Marine Park.

The Wunambal Gaambera people's country includes daagu (deep waters), with about 3,400km² of their sea country located in the Marine Park.

The national heritage listing for the West Kimberley also recognises the following key cultural heritage values:

cultural tradition of the Wanjina Wungurr people incorporates many sea country cultural sites
 log-raft maritime tradition, which involved using tides and currents to access warruru (reefs) far offshore to fish;

interactions with Makassan traders around sea foods over hundreds of years

important pearl resources that were used in traditional trade through the wunan and in contemporary commercial agreements.

Heritage values

No international, Commonwealth or national heritage listings apply to the Marine Park.

The Marine Park contains over 40 known historic shipwrecks (Section 4.6.2).

Social and economic values

Tourism, commercial fishing, mining, recreation, including fishing, and traditional use are important activities in the Marine Park.

Ashmore Reef Marine Park

The Ashmore Reef Marine Park is located approx. 630km north of Broome and 110km south of the Indonesian island of Roti. The Marine Park is located in Australia's External Territory of Ashmore and Cartier Islands and is within an area subject to a Memorandum of Understanding (MoU) between Indonesia and Australia, known as the MoU Box.

The Marine Park covers an area of 583km² and water depths from less than 15 m to 500 m. The Marine Park contains three vegetated sand cays that are permanently above water: West, Middle and East islands. The Marine Park is assigned IUCN category Ia and includes two zones assigned under this plan: Sanctuary Zone (Ia) and Recreational Use Zone (IV).

Statement of significance

The Ashmore Reef Marine Park is significant because it includes habitats, species and ecological communities associated with the Timor Province. It includes two key ecological features: Ashmore Reef and Cartier Island and surrounding Commonwealth waters (valued for high productivity and breeding aggregations of birds and other marine life); and continental slope demersal fish communities (valued for high levels of endemism). Ashmore Reef is the largest of three emergent oceanic reefs in the region and the only one with vegetated islands. The Marine Park is an area of enhanced biological productivity and a biodiversity hotspot, supporting a range of pelagic and benthic marine species and an important biological stepping stone facilitating the transport of biological material to the reef systems along the Western Australian coast via the south-flowing Leeuwin Current which originates in the region. The Ashmore Reef Ramsar site is located within the boundary of the Marine Park. The site was listed under the Ramsar Convention in 2002 and is a wetland of international importance under the EPBC Act. An Ecological Character Description that sets out the Ramsar listing criteria met by the site, the key threats and knowledge gaps, is available on the Department's website.

Natural values

Examples of ecosystems representative of the Timor Province—a bioregion with a depth range from about 200 m near the shelf break to 5920 m over the Argo Abyssal Plain. The reefs and islands of the bioregion are regarded as biodiversity hotspots. Ashmore Reef is an important feature of the bioregion. Endemism in demersal fish communities of the continental slope is high with two distinct communities identified: one on the upper slope, the other mid slope.

North-West Marine Region

Key ecological features:

Ashmore Reef and Cartier Island and surrounding Commonwealth waters—areas of enhanced productivity in an otherwise low-nutrient environment, of regional importance for feeding and breeding aggregations of birds and marine life; and continental slope demersal fish communities—an area of high-diversity demersal fish assemblages. The marine environment of the Marine Park includes habitats associated with two extensive lagoons, sand flats, shifting sand cays, extensive reef flat and large areas of seagrass. The reef ecosystems are comprised of hard and soft corals, gorgonians, sponges and a range of encrusting organisms, with the highest number of coral species of any reef off the Western Australian coast.

Supports a range of species, including species listed as threatened, migratory, marine or cetacean under the EPBC Act.

Biologically important areas within the Marine Park include breeding, foraging and resting habitat for seabirds, resting and foraging habitat for migratory shorebirds, foraging, mating, nesting and internesting habitat for marine turtles, foraging habitat for dugong, and a migratory pathway for pygmy blue whales.

The Ashmore Reef Ramsar site includes the largest of the atolls in the region. West Island, Middle Island and East Island represent the only vegetated islands in the region. Ashmore Reef Ramsar site supports internationally significant populations of seabirds and shorebirds, is important for turtles (green, hawksbill and loggerhead) and dugong, and has the highest diversity of hermatypic (reef-building) corals on the West Australian coast. It is known for its abundance and diversity of sea snakes. However, since 1998 populations of sea snakes at Ashmore Reef have been in decline.

Cultural values

Indigenous Australians Sea country is valued for Indigenous cultural identity, health and wellbeing.

The Marine Park contains Indonesian artefacts and grave sites and Ashmore lagoon is still accessed as a rest or staging area for traditional Indonesian fishers travelling to and from fishing grounds within the MoU Box.

Heritage values

No international or national heritage listings apply to the Marine Park at commencement of this plan.

Commonwealth heritage

Ashmore Reef was listed on the Commonwealth Heritage List in 2004, meeting Commonwealth heritage listing criteria A, B and C.

Social and economic values

Tourism, recreation and scientific research are important activities in the Marine Park. These activities contribute to the wellbeing of regional communities and the prosperity of the nation.

Cartier Island Marine Park

The Cartier Island Marine Park is located approx. 45km south-east of Ashmore Reef Marine Park and 610km north of Broome, Western Australia. Both Marine Parks are located in Australia's External Territory of Ashmore and Cartier Islands and are also within an area subject to a MoU between Indonesia and Australia, known as the MoU Box.

The Marine Park covers an area of 17 km² and water depths from less than 15 m to 500 m. The Marine Park is assigned IUCN category Ia and includes one zone assigned under this plan: Sanctuary Zone (Ia).

Statement of significance

The Cartier Island Marine Park is significant because it includes habitats, species and ecological communities associated with the Timor Province. It includes two key ecological features: Ashmore Reef and Cartier Island and surrounding Commonwealth waters (valued for high productivity and breeding aggregations of birds and other marine life); and continental slope demersal fish communities (valued for high levels of endemism). Like the islands of Ashmore Reef, Cartier Island is a biodiversity hotspot and an important biological stepping stone, facilitating the transport of biological material to the reef systems along the Western Australian coast via the south-flowing Leeuwin Current which originates in the region.

North-West Marine Region

Natural values

Examples of ecosystems representative of the:

Timor Province—a bioregion with a depth range from about 200 m near the shelf break to 5920 m over the Argo Abyssal Plain. The reefs and islands of the bioregion are regarded as biodiversity hotspots. Endemism of demersal fish communities of the continental slope is high with two distinct communities identified, one on the upper slope, the other mid slope.

Key ecological features:

Ashmore Reef and Cartier Island and surrounding Commonwealth waters—areas of enhanced productivity in an otherwise low-nutrient environment, of regional importance for feeding and breeding aggregations of birds and marine life; and

Continental slope demersal fish communities—an area of high diversity in demersal fish assemblages. The Marine Park includes an unvegetated sand island (Cartier Island), mature reef flat, a small, submerged pinnacle (Wave Governor Bank), and two shallow pools to the north-east of the island. It is also an area of high diversity and abundance of hard and soft corals, gorgonians (sea fans), sponges and a range of encrusting organisms. The reef crests are generally algal dominated, while the reef flats feature ridges of coral rubble and large areas of seagrass.

The Marine Park supports a range of species, including species listed as threatened, migratory, marine or cetacean under the EPBC Act.

Biologically important areas within the Marine Park include breeding and foraging habitat for seabirds, interesting, nesting and foraging habitat for marine turtles and foraging habitat for whale sharks.

Important for a range of other species and internationally significant for its abundance and diversity of sea snakes, some of which are listed species under the EPBC Act.

Cultural values

Sea country is valued for Indigenous cultural identity, health and wellbeing.

At the commencement of this plan, there is limited information about the cultural significance of this Marine Park.

Heritage values

No international, Commonwealth or national listings apply to the Marine Park at commencement of this plan.

Historic shipwrecks

The Marine Park contains one known shipwreck listed under the Historic Shipwrecks Act 1976: the Ann Millicent (wrecked in 1888).

Social and economic values

Scientific research is an important activity in the Marine Park.

Argo-Rowley Terrace Marine Park

The Argo-Rowley Terrace Marine Park is located approx. 270km north-west of Broome. The Marine Park is adjacent to the Mermaid Reef Marine Park and the State Rowley Shoals Marine Park. The Marine Park covers an area of 146,003km² and water depths of 220–6,000 m. The Marine Park includes three zones: National Park Zone (II), Multiple Use Zone (VI) and Special Purpose Zone (Trawl) (VI).

Statement of significance

The Argo-Rowley Marine Park is significant because it contains habitats, species and ecological communities associated with the Northwest Transition and Timor Province, and includes two KEFs. The Marine Park is the largest in the North-west Network. It includes the deeper waters of the region and a range of seafloor features (e.g. canyons on the slope between the Argo Abyssal Plain, Rowley Terrace and Scott Plateau). These are believed to be up to 50 million years old and are associated with small, periodic upwellings that results in localised higher levels of biological productivity.

Natural values

North-West Marine Region

Examples of ecosystems representative of the:

Northwest Transition, an area of shelf break, continental slope, and the majority of the Argo Abyssal Plain. Together with Clerke Reef and Imperieuse Reef, Mermaid Reef is a biodiversity hotspot and key topographic feature of the Argo Abyssal Plain.

Timor Province, an area dominated by warm, nutrient-poor waters. Canyons are an important feature in this area of the Marine Park and are generally associated with high productivity and aggregations of marine life.

Contains two KEFs: Canyons linking the Argo Abyssal Plain with the Scott Plateau, and Mermaid Reef and Commonwealth waters surrounding Rowley Shoals (Section 4.6.8).

Supports a range of species, including species listed as threatened, migratory, marine or cetacean under the EPBC Act.

BIAs within the Marine Park include resting and breeding habitat for seabirds and a migratory pathway for the pygmy blue whale.

Cultural values

Sea country is valued for Indigenous cultural identity, health and wellbeing. However, to date there is limited information about the cultural significance of this Marine Park.

Heritage values

No international, Commonwealth or national heritage listings apply to the Marine Park.

The Marine Park contains two known historic shipwrecks: Alfred (1908) and Pelsart (1908) (Section 4.6.2).

Social and economic values

Commercial fishing and mining are important activities in the Marine Park.

Mermaid Reef Marine Park

The Mermaid Reef Marine Park is located approx. 280km north-west of Broome, adjacent to the Argo–Rowley Terrace Marine Park and approx. 13km from the WA Rowley Shoals Marine Park. The Marine Park covers an area of 540km² and covers water depths from <15 m to 500 m. The Marine Park includes one zone: National Park Zone (II).

Statement of significance

The Marine Park is significant because it contains habitats, species and ecological communities associated with the Northwest Transition and includes one KEF. Mermaid Reef is one of three reefs forming the Rowley Shoals; the others are Clerke Reef and Imperieuse Reef and occur to the south-west of the Marine Park. The Rowley Shoals have been described as the best geological examples of shelf atolls in Australian waters.

The reefs of the Rowley Shoals are ecologically significant in that they are considered ecological stepping-stones for reef species originating in Indonesian/Western Pacific waters, are one of a few offshore reef systems on the north-west shelf, and may also provide an upstream source for recruitment to reefs further south.

Natural values

Examples of ecosystems representative of the Northwest Transition, an area of shelf break, continental slope, and the majority of the Argo Abyssal Plain. Together with Clerke Reef and Imperieuse Reef, Mermaid Reef is a biodiversity hotspot and key topographic feature of the Argo Abyssal Plain.

Contains one KEF: Mermaid Reef and Commonwealth waters surrounding Rowley Shoals (Section 4.6.8).

Ecosystems are associated with emergent reef flat, deep reef flat, lagoon, and submerged sand habitats.

Supports a range of species, including species listed as threatened, migratory, marine or cetacean under the EPBC Act.

BIAs within the Marine Park include breeding habitat for seabirds and a migratory pathway for the pygmy blue whale.

North-West Marine Region

Cultural values

Sea country is valued for Indigenous cultural identity, health and wellbeing. However, to date there is limited information about the cultural significance of this Marine Park.

Heritage values

No international or national heritage listings apply to the Marine Park.

The Marine Park surrounds the Mermaid Reef – Rowley Shoals Commonwealth Heritage Place (Section 4.6.3).

The Marine Park contains one known historic shipwreck: Lively (1810) (Section 4.6.2).

Social and economic values

Tourism, recreation, and scientific research are important activities in the Marine Park.

Roebuck Marine Park

The Roebuck Marine Park is located approximately 12km offshore of Broome, and is adjacent to the Western Australian Yawuru Nagulagun/Roebuck Bay Marine Park. The Marine Park covers an area of 304km² and a water depth range of less than 15 m to 70 m.

The Marine Park was proclaimed under the EPBC Act on 14 December 2013 and renamed Roebuck Marine Park on 9 October 2017.

The Marine Park is assigned IUCN category VI and includes one zone assigned under this plan: Multiple Use Zone (VI).

Statement of significance

The Roebuck Marine Park is significant because it contains habitats, species and ecological communities associated with the Northwest Shelf Province, and consists entirely of shallow continental shelf habitat. The Marine Park is adjacent to the Roebuck Bay Ramsar site, recognised as one of the most important areas for migratory shorebirds in Australia; and the Western Australian Yawuru Nagulagun/Roebuck Bay Marine Park, providing connectivity between offshore and inshore coastal waters of Roebuck Bay.

Natural values

Examples of ecosystems representative of the:

Northwest Shelf Province—a dynamic environment influenced by strong tides, cyclonic storms, long-period swells and internal tides. The bioregion includes diverse benthic and pelagic fish communities, and ancient coastline thought to be an important seafloor feature and migratory pathway for humpback whales.

The Marine Park supports a range of species including species listed as threatened, migratory, marine or cetacean under the EPBC Act.

Biologically important areas within the Marine Park include breeding and resting habitat for seabirds, foraging and interning habitat for marine turtles, a migratory pathway for humpback whales and foraging habitat for dugong.

Cultural values

Sea country is valued for Indigenous cultural identity, health and wellbeing.

Yawuru people have always recognised the waters of Roebuck Bay as nagula (Yawuru sea country), and have customary responsibilities to care for it. They have a deep spiritual connection to offshore landscapes from Bugarrigarra (creator beings), and believe that snake-like metaphysical beings inhabit the sea.

Cultural sites in sea country are also a source of law. The Yawuru people harvest marine resources according to the six Yawuru seasons. They have harvested pearl shell for food and cultural purposes. Fish are a staple food source, and fishing a form of cultural expression, connecting people to their country, modelled on tradition and based in traditional law. Access to sea country by families is important to cultural traditions, livelihoods and future socio-economic development opportunities.

The Yawuru Native Title Holders Aboriginal Corporation is the Prescribed Body Corporate representing traditional owners with native title over coastal areas adjacent to the Marine Park, and is the point of

North-West Marine Region

contact for sea country in the Marine Park. The Kimberley Land Council is the Native Title Representative Body for the Kimberley region.

Heritage values

No international, Commonwealth or national listings apply to the Marine Park at commencement of this plan, however the Marine Park is adjacent to the West Kimberley National Heritage Place.

Social and economic values

Tourism, commercial fishing, pearling and recreation, including fishing, are important activities that occur in the Marine Park. These activities contribute to the wellbeing of regional communities and the prosperity of the nation.

Eighty Mile Beach Marine Park

The Eighty Mile Beach Marine Park is located approx. 74km north-east of Port Hedland, adjacent to the State Eighty Mile Beach Marine Park. The Marine Park covers an area of 10,785km² and covers water depths from <15 m to 70 m. The Marine Park includes one zone: Multiple Use Zone (VI).

Statement of significance

The Marine Park is significant because it contains habitats, species and ecological communities associated with the Northwest Shelf Province and consists of shallow shelf habitats, including terrace, banks and shoals. The Marine Park is adjacent to the Eighty Mile Beach Ramsar site, recognised as one of the most important areas for migratory shorebirds in Australia; and the State Eighty Mile Beach Marine Park, providing connectivity between offshore and inshore coastal waters of Eighty Mile Beach.

Natural values

Examples of ecosystems representative of the Northwest Shelf Province, a dynamic environment influenced by strong tides, cyclonic storms, long-period swells and internal tides, the region includes diverse benthic and pelagic fish communities, and ancient coastline thought to be an important seafloor feature and migratory pathway for humpback whales.

Supports a range of species, including species listed as threatened, migratory, marine or cetacean under the EPBC Act.

BIAs within the Marine Park include breeding, foraging and resting habitat for seabirds, internesting and nesting habitat for marine turtles, foraging, nursing and pupping habitat for sawfish and a migratory pathway for humpback whales.

Cultural values

Sea country is valued for Indigenous cultural identity, health and wellbeing. The Nyangumarta, Karajarri and Ngarla people have responsibilities for sea country in the Marine Park.

Heritage values

No international, Commonwealth or national heritage listings apply to the Marine Park.

The Marine Park contains three known historic shipwrecks: Lorna Doone (1923), Nellie (1908) and Tifera (1923) (Section 4.6.2).

Social and economic values

Tourism, commercial fishing, pearling and recreation are important activities in the Marine Park.

Dampier Marine Park

The Dampier Marine Park is located approx. 10km north-east of Cape Lambert and 40km from Dampier extending from the WA state water boundary. The Marine Park covers an area of 1,252km² and a water depth range from <15 m to 70 m. The Marine Park includes three zones: National Park Zone (II), Habitat Protection Zone (IV) and Multiple Use Zone (VI).

Statement of significance

The Dampier Marine Park is significant because it contains habitats, species and ecological communities associated with the Northwest Shelf Province. The Marine Park provides protection for offshore shelf

North-West Marine Region

habitats adjacent to the Dampier Archipelago, and the area between Dampier and Port Hedland, and is a hotspot for sponge biodiversity. The Marine Park includes several submerged coral reefs and shoals including Delambre Reef and Tessa Shoals.

Natural values

Examples of ecosystems representative of the Northwest Shelf Province, a dynamic environment influenced by strong tides, cyclonic storms, long-period swells and internal tides, the region includes diverse benthic and pelagic fish communities, and ancient coastline thought to be an important seafloor feature and migratory pathway for humpback whales.

Supports a range of species, including species listed as threatened, migratory, marine or cetacean under the EPBC Act.

BIAs within the Marine Park include breeding and foraging habitat for seabirds, interesting habitat for marine turtles and a migratory pathway for humpback whales.

Cultural values

Sea country is valued for Indigenous cultural identity, health and wellbeing. The Ngarluma, Yindjibarndi, Yaburara, and Mardudhunera people have responsibilities for sea country in the Marine Park.

Heritage values

No international, Commonwealth or national heritage listings apply to the Marine Park.

Social and economic values

Port activities, commercial fishing and recreation, including fishing, are important activities in the Marine Park.

Montebello Marine Park

The Montebello Marine Park is located offshore of Barrow Island and 80km west of Dampier extending from the WA State water boundary. The Marine Park covers an area of 3,413km² and water depths from <15 m to 150 m. The Marine Park includes one IUCN zone: Multiple Use Zone (IUCN VI).

Statement of significance

The Montebello Marine Park is significant because it contains habitats, species and ecological communities associated with the Northwest Shelf Province. The Marine Park includes one KEF, the ancient coastline at the 125-m depth contour (Section 4.6.8). The Marine Park provides connectivity between deeper waters of the continental shelf and slope, and the adjacent State Barrow Island and Montebello Islands Marine Parks. A prominent seafloor feature in the Marine Park is Trial Rocks consisting of two close coral reefs; these reefs are emergent at low tide.

Natural values

Examples of ecosystems representative of the Northwest Shelf Province, a dynamic environment influenced by strong tides, cyclonic storms, long-period swells and internal tides, the region includes diverse benthic and pelagic fish communities.

Contains one KEF: the ancient coastline at the 125-m depth contour.

Supports a range of species, including species listed as threatened, migratory, marine or cetacean under the EPBC Act.

BIAs within the Marine Park include breeding habitat for seabirds, interesting, foraging, mating, and nesting habitat for marine turtles, a migratory pathway for humpback whales and foraging habitat for whale sharks.

Cultural values

Sea country is valued for Indigenous cultural identity, health and wellbeing. However, to date there is limited information about the cultural significance of this Marine Park.

Heritage values

No international, Commonwealth or national heritage listings apply to the Marine Park.

North-West Marine Region

The Marine Park contains two known historic shipwrecks: Trial (1622) and Tanami (unknown date) (Section 4.6.2).

Social and economic values

Tourism, commercial fishing, mining and recreation are important activities in the Marine Park.

Ningaloo Marine Park

The Ningaloo Marine Park stretches approx. 300km along the west coast of the Cape Range Peninsula, and is adjacent to the State Ningaloo Marine Park and Commonwealth Gascoyne Marine Park. The Marine Park covers an area of 2,435km² and occurs over a water depth range of 30 m to >500 m. The Marine Park contains zones designated as National Park Zone (IUCN II) and Recreational Use Zone (IUCN IV).

Statement of significance

The Ningaloo Marine Park is significant because it contains habitats, species and ecological communities associated with the Central Western Shelf Transition, Central Western Transition, Northwest Province, and Northwest Shelf Province; and contains three KEFs.

The Marine Park provides connectivity between deeper offshore waters of the shelf break and shallower coastal waters. It includes some of the most diverse continental slope habitats in Australia, in particular the continental slope area between North West Cape and the Montebello Trough. Canyons in the Marine Park are important for their role in sustaining the nutrient conditions that support the high diversity of Ningaloo Reef. The Marine Park is located in a transition zone between tropical and temperate waters and sustains tropical and temperate flora and fauna, with many species at the limits of their distributions.

Natural values

Examples of ecosystems representative of the:

Central Western Shelf Transition, an area of continental shelf of water depths up to 100 m, and a significant transition zone between tropical and temperate species

Central Western Transition, characterised by large areas of continental slope, a range of topographic features (e.g. terraces, rises and canyons), seasonal and sporadic upwelling, and benthic slope communities comprising tropical and temperate species

Northwest Province, an area of continental slope comprising diverse and endemic fish communities

Northwest Shelf Province, an area influenced by strong tides, cyclonic storms, long-period swells and internal tides; this region includes diverse benthic and pelagic fish communities, and ancient coastline thought to be an important seafloor feature and migratory pathway for humpback whales.

Contains three KEFs: Canyons linking the Cuvier Abyssal Plain and the Cape Range Peninsula, Commonwealth waters adjacent to Ningaloo Reef, and Continental slope demersal fish communities.

Ecosystems are influenced by the Leeuwin and Ningaloo currents, and the Leeuwin undercurrent.

Supports a range of species, including species listed as threatened, migratory, marine or cetacean under the EPBC Act.

BIAs within the Marine Park include breeding and or foraging habitat for seabirds, interesting habitat for marine turtles, a migratory pathway for humpback whales, foraging habitat and migratory pathway for pygmy blue whales, breeding, calving, foraging and nursing habitat for dugong and foraging habitat for whale sharks.

Cultural values

Sea country is valued for Indigenous cultural identity, health and wellbeing. The Gnulli people have responsibilities for sea country in the Marine Park.

Heritage values

The Marine Park is within the Ningaloo Coast World Heritage Property, adjacent to the Ningaloo Coast National Heritage Place, and within the Ningaloo Marine Area (Commonwealth waters) Commonwealth Heritage Place (Section 4.6).

The Marine Park contains over 15 known historic shipwrecks (Section 4.6.2).

North-West Marine Region
<p>Social and economic values</p> <p>Tourism and recreation (including fishing) are important activities in the Marine Park</p>
Gascoyne Marine Park
<p>The Gascoyne Marine Park is located approx. 20km off the west coast of the Cape Range Peninsula, adjacent to the State and Commonwealth Ningaloo Marine Parks. The Marine Park covers an area of 81,766km² and over water depths between 15–6,000 m. The Marine Park contains zones designated as National Park Zone (IUCN II), Habitat Protection Zone (IUCN IV) and Multiple Use Zone (IUCN VI).</p> <p>Statement of significance</p> <p>The Gascoyne Marine Park is significant because it contains habitats, species and ecological communities associated with the Central Western Shelf Transition, Central Western Transition, and Northwest Province, and includes four KEFs.</p> <p>The Marine Park includes some of the most diverse continental slope habitats in Australia, in particular the continental slope area between North West Cape and the Montebello Trough. Canyons in the Marine Park link the Cuvier Abyssal Plain to the Cape Range Peninsula and are important for their role in sustaining the nutrient conditions that support the high diversity of Ningaloo Reef.</p> <p>Natural values</p> <p>Examples of ecosystems representative of the:</p> <p>Central Western Shelf Transition, an area of continental shelf of water depths up to 100 m, and a significant transition zone between tropical and temperate species</p> <p>Central Western Transition, characterised by large areas of continental slope, a range of topographic features (e.g. terraces, rises and canyons), seasonal and sporadic upwelling, and benthic slope communities comprising tropical and temperate species</p> <p>Northwest Province, an area of continental slope comprising diverse and endemic fish communities.</p> <p>Contains four KEFs: Canyons linking the Cuvier Abyssal Plain and the Cape Range Peninsula, Commonwealth waters adjacent to Ningaloo Reef, Continental slope demersal fish communities, and the Exmouth Plateau (Section 4.6.8).</p> <p>Ecosystems are influenced by the Leeuwin and Ningaloo currents, and the Leeuwin undercurrent.</p> <p>Supports a range of species, including species listed as threatened, migratory, marine or cetacean under the EPBC Act.</p> <p>BIAs within the Marine Park include breeding habitat for seabirds, internesting habitat for marine turtles, a migratory pathway for humpback whales, and foraging habitat and migratory pathway for pygmy blue whales.</p> <p>Cultural values</p> <p>Sea country is valued for Indigenous cultural identity, health and wellbeing. The Gnulli people have responsibilities for sea country in the Marine Park.</p> <p>Heritage values</p> <p>The Marine Park is adjacent to Ningaloo Coast World Heritage Property and National Heritage Place, and the Ningaloo Marine Area (Commonwealth waters) Commonwealth Heritage Place (Section 4.6).</p> <p>The Marine Park contains over 5 known historic shipwrecks (Section 4.6.2).</p> <p>Social and economic values</p> <p>Commercial fishing, mining and recreation are important activities in the Marine Park.</p>
Carnarvon Canyon Marine Park
<p>The Carnarvon Canyon Marine Park is located approximately 300km north-west of Carnarvon. It covers an area of 6,177km² and occurs over a water depth range of 1,500–6,000 m. The Marine Park includes one IUCN zone: Habitat Protection Zone (IUCN IV).</p>

North-West Marine Region

Statement of significance

The Carnarvon Canyon Marine Park is significant because it contains habitats, species and ecological communities associated with the Central Western Transition, including deep-water ecosystems associated with the Carnarvon Canyon. The Marine Park lies within a transition zone between tropical and temperate species and is an area of high biotic productivity.

Natural values

Examples of ecosystems representative of the Central Western Transition, which is a bioregion characterised by large areas of continental slope, a range of topographic features (e.g. terraces, rises and canyons), seasonal and sporadic upwelling, and benthic slope communities comprising tropical and temperate species.

The Carnarvon Canyon is a single-channel canyon covering the entire depth range of the Marine Park.

Ecosystems are influenced by tropical and temperate currents, deep-water environments and proximity to the continental slope and shelf.

The soft-bottom environment at the base of the Carnarvon Canyon is likely to support species that are typical of the deep seafloor (e.g. holothurians, polychaetes and sea-pens).

Supports a range of species including species listed as threatened, migratory, marine or cetacean under the EPBC Act.

Cultural values

Sea country is valued for Indigenous cultural identity, health and wellbeing. However, to date there is limited information about the cultural significance of this Marine Park.

Heritage values

No international, Commonwealth or national heritage listings apply to the Marine Park.

Social and economic values

Commercial fishing is an important activity in the Marine Park.

Shark Bay Marine Park

The Shark Bay Marine Park is located approximately 60km offshore of Carnarvon, adjacent to the Shark Bay world heritage property and national heritage place. The Marine Park covers an area of 7,443km², extending from the WA state water boundary, over a water depth range of 15–220 m. The Marine Park includes one IUCN zone: Multiple Use Zone (IUCN VI).

Statement of significance

The Shark Bay Marine Park is significant because it contains habitats, species and ecological communities associated with the Central Western Shelf Province and Central Western Transition. The Marine Park provides connectivity between deeper Commonwealth waters and the inshore waters of the Shark Bay world heritage property.

Natural values

Examples of ecosystems representative of the:

Central Western Shelf, which is a predominantly flat, sandy and low-nutrient area, in water depths of 50–100 m; this region is a transitional zone between tropical and temperate species

Central Western Transition, which is characterised by large areas of continental slope, a range of topographic features such as terraces, rises and canyons, seasonal and sporadic upwelling, and benthic slope communities comprising tropical and temperate species.

Ecosystems are influenced by the Leeuwin, Ningaloo and Capes currents.

Supports a range of species including species listed as threatened, migratory, marine or cetacean under the EPBC Act.

BIAs within the Marine Park include breeding habitat for seabirds, internesting habitat for marine turtles, and a migratory pathway for humpback whales.

North-West Marine Region

The Marine Park and adjacent coastal areas are also important for shallow-water snapper.

Cultural values

Sea country is valued for Indigenous cultural identity, health and wellbeing. The Gnulli and Malgana people have responsibilities for sea country in the Marine Park.

Heritage values

No international, Commonwealth or national heritage listings apply to the Marine Park.

The Marine Park contains approx. 20 known historic shipwrecks (Section 4.6.2).

Social and economic values

Tourism, commercial fishing, mining and recreation are important activities in the Marine Park.

South-west Marine Region

Abrolhos Marine Park

The Abrolhos Marine Park is located adjacent to the Houtman Abrolhos Islands and extends from approx. 27km south-west of Geraldton north to approx. 330km west of Carnarvon. The Marine Park covers an area of 88,060km² and a water depth range from <15 m to 6,000 m. The Marine Park includes four zones: National Park Zone (II), Habitat Protection Zone (IV), Multiple Use Zone (VI) and Special Purpose Zone (VI).

Statement of significance

The Abrolhos Marine Park is significant because it contains habitats, species and ecological communities associated with the Central Western Province, Central Western Shelf Province, Central Western Transition and South-west Shelf Transition regions, and includes seven KEFs. The southern shelf component of the Marine Park partially surrounds the State Houtman Abrolhos Islands Nature Reserve. The islands and surrounding reefs are renowned for their high level of biodiversity, due to the southward movement of species by the Leeuwin Current. The Marine Park contains several seafloor features including the Houtman Canyon, the second largest submarine canyon on the west coast.

Natural values

Examples of ecosystems representative of the:

Central Western Province, characterised by a narrow continental slope incised by many submarine canyons and the most extensive area of continental rise in any of Australia's marine regions. A significant feature within the area are several eddies that form off the Leeuwin Current at predictable locations, including west of the Houtman Abrolhos Islands.

Central Western Shelf Province, a predominantly flat, sandy and low nutrient area, in water depths of 50–100 m. Significant seafloor features of this area include a deep hole and associated area of banks and shoals offshore of Kalbarri. The area is a transitional zone between tropical and temperate species.

Central Western Transition, a deep ocean area characterised by large areas of continental slope, a range of significant seafloor features including the Wallaby Saddle, seasonal and sporadic upwelling, and benthic slope communities comprising tropical and temperate species.

South-west Shelf Transition, an area of narrow continental shelf that is noted for its physical complexity. The Leeuwin Current has a significant influence on the biodiversity of this nearshore area as it pushes subtropical water southward along the area's western edge. The area contains a diversity of tropical and temperate marine life including a large number of endemic fauna species.

Contains seven KEFs: Commonwealth marine environment surrounding the Houtman Abrolhos Islands, Demersal slope and associated fish communities of the Central Western Province, Mesoscale eddies, Perth Canyon and adjacent shelf break, and other west-coast canyons, Western rock lobster, Ancient coastline between 90 m and 120 m depth, and the Wallaby Saddle (Section 4.6.8).

Supports a range of species including species listed as threatened, migratory, marine or cetacean under the EPBC Act.

South-west Marine Region

BIAs within the Marine Park include foraging and breeding habitat for seabirds, foraging habitat for Australian sea lions and white sharks, and a migratory pathway for humpback and pygmy blue whales. The Marine Park is adjacent to the northernmost Australian sea lion breeding colony in Australia on the Houtman Abrolhos Islands.

Cultural values

Sea country is valued for Indigenous cultural identity, health and wellbeing. The Nanda and Naaguja people have responsibilities for sea country in the Marine Park.

Heritage values

No international, Commonwealth or national heritage listings apply to the Marine Park.

The Marine Park contains 11 known historic shipwrecks (Section 4.6.2).

Social and economic values

Tourism, commercial fishing, mining, recreation including fishing, are important activities in the Marine Park.

Jurien Marine Park

The Jurien Marine Park is located approx. 148km north of Perth and 155km south of Geraldton, adjacent to the State Jurien Bay Marine Park. The Marine Park covers an area of 1,851km² of continental shelf, and over water depths of 15–220 m. The Marine Park includes two zones: National Park Zone (II) and Special Purpose Zone (VI).

Statement of significance

The Jurien Marine Park is significant because it includes habitats, species and ecological communities associated with the South-west Shelf Transition and Central Western Province, and includes three KEFs. The Marine Park contains a mixture of tropical species carried south by the Leeuwin Current, and temperate species carried north by the Capes Current. The Marine Park's shelf habitats are defined by distinct ridges of limestone reef with extensive beds of macroalgae. Inshore lagoons are inhabited by a diverse range of invertebrates and fish. Seagrass meadows occur in more sheltered areas as well as in the inter-reef lagoons along exposed sections of the coast. The Marine Park includes habitats connecting to and complementing the adjacent State Jurien Bay Marine Park.

Natural values

Examples of ecosystems representative of the:

South-west Shelf Transition, an area of narrow continental shelf that is noted for its physical complexity. The Leeuwin Current has a significant influence on the biodiversity of this nearshore area as it pushes subtropical water southward along the area's western edge. The area contains a diversity of tropical and temperate marine life including a large number of endemic fauna species.

Central Western Province, characterised by a narrow continental slope and influenced by the Leeuwin Current.

Contains three KEFs: Demersal slope and associated fish communities of the Central Western Province, Western rock lobster and Ancient coastline between 90 m and 120 m depth (Section 4.6.8).

Supports a range of species including species listed as threatened, migratory, marine or cetacean under the EPBC Act.

BIAs within the Marine Park include foraging habitat for seabirds, Australian sea lions and white sharks, and a migratory pathway for humpback and pygmy blue whales.

Cultural values

Sea country is valued for Indigenous cultural identity, health and wellbeing. The Noongar people have responsibilities for sea country in the Marine Park.

Heritage values

No international, Commonwealth or national heritage listings apply to the Marine Park.

South-west Marine Region
<p>The Marine Park contains two known historic shipwrecks: SS Cambewarra (1914) and Oleander (1884) (Section 4.6.2).</p> <p>Social and economic values</p> <p>Tourism, commercial fishing, mining and recreation, including fishing, are important activities in the Marine Park.</p>
Two Rocks Marine Park
<p>The Two Rocks Marine Park is located approx. 25km north-west of Perth. The Marine Park covers an area of 882km², over a water depth range from 15–120 m. The Marine Park includes two zones: National Park Zone (II) and Multiple Use Zone (VI).</p> <p>Statement of significance</p> <p>The Two Rocks Marine Park is significant because it includes habitats, species and ecological communities associated with the South-west Shelf Transition and includes three KEFs. The Marine Park is shallow and provides connectivity between offshore waters and the west coast inshore lagoons, which are key areas for the recruitment of rock lobster and other commercially and recreationally important fish species.</p> <p>Natural values</p> <p>Examples of ecosystems representative of the South-west Shelf Transition, an area of narrow continental shelf that is noted for its physical complexity. The Leeuwin Current has a significant influence on the biodiversity of this nearshore area as it pushes subtropical water southward along the area's western edge. The area contains a diversity of tropical and temperate marine life including a large number of endemic fauna species.</p> <p>The inshore lagoons are thought to be important areas for benthic productivity and recruitment for a range of marine species.</p> <p>Contains three KEFs: Commonwealth marine environment within and adjacent to the west-coast inshore lagoons, Western rock lobster and Ancient coastline between 90 m and 120 m depth (Section 4.6.8).</p> <p>Supports a range of species including species listed as threatened, migratory, marine or cetacean under the EPBC Act.</p> <p>BIAs within the Marine Park include foraging habitat for seabirds and Australian sea lions, a migratory pathway for humpback and pygmy blue whales, and a calving buffer area for southern right whales.</p> <p>Cultural values</p> <p>Sea country is valued for Indigenous cultural identity, health and wellbeing. The Swan River traditional owners have responsibilities for sea country in the Marine Park.</p> <p>Heritage values</p> <p>No international, Commonwealth or national heritage listings apply to the Marine Park.</p> <p>Social and economic values</p> <p>Tourism, commercial fishing, recreation, including fishing, and scientific research are important activities in the Marine Park.</p>
Perth Canyon Marine Park
<p>The Perth Canyon Marine Park is located approx. 52km west of Perth and approx. 19km west of Rottnest Island. The Marine Park covers an area of 7,409km² and covers water depths of 120–5,000 m. The Marine Park includes three zones: National Park Zone (II), Habitat Protection Zone (IV) and Multiple Use Zone (VI).</p> <p>Statement of significance</p> <p>The Marine Park is significant because it includes habitats, species and ecological communities associated with the Central Western Province, South-west Shelf Province, Southwest Transition and South-west Shelf Transition; and also includes four KEFs. The Marine Park includes the majority of the Perth Canyon, Australia's largest submarine canyon, which is home to the largest feeding aggregations of blue whales in Australia. This unique feature is also of significance because it cuts into the continental shelf at</p>

South-west Marine Region

approximately 150 m depth west of Rottnest Island, linking the shelf with deeper (up to 5,000 m) ecosystems. The Marine Park represents the southern end of the transition area from tropical to temperate marine environments.

Natural values

Examples of ecosystems representative of the:

Central Western Province, characterised by a narrow continental slope incised by many submarine canyons (including Perth Canyon), and the most extensive area of continental rise in any of Australia's marine regions. A significant feature within the area are several eddies that form off the Leeuwin Current at predictable locations (including the Perth Canyon).

South-west Shelf Province, an area of diverse marine life, influenced by the warm waters of the Leeuwin Current

South-west Transition, characterised by the submarine canyons that incise the northern parts of the slope and the deep-water mixing that results from the dynamics of major ocean currents when these meet the seafloor (particularly in the Perth Canyon).

South-west Shelf Transition, an area that consists of a narrow continental shelf that is noted for its physical complexity. The Leeuwin Current has a significant influence on the biodiversity of this nearshore area as it pushes subtropical water southward along the area's western edge. The area contains a diversity of tropical and temperate marine life including a large number of endemic fauna species.

Contains four KEFs: Perth Canyon and adjacent shelf break, and other west-coast canyons, Demersal slope and associated fish communities of the Central Western Province, Western rock lobster and Mesoscale eddies (Section 4.6.8).

Supports a range of species including species listed as threatened, migratory, marine or cetacean under the EPBC Act.

BIAs within the Marine Park include foraging habitat for seabirds, Antarctic blue, pygmy blue and sperm whales, a migratory pathway for humpback, Antarctic blue and pygmy blue whales, and a calving buffer area for southern right whales.

Cultural values

Sea country is valued for Indigenous cultural identity, health and wellbeing. The Swan River traditional owners have responsibilities for sea country in the Marine Park.

Heritage values

No international, Commonwealth or national heritage listings apply to the Marine Park.

Social and economic values

Tourism, commercial shipping, commercial fishing, recreation, including fishing, and defence training are important activities in the Marine Park.

4.6.5.2 Commonwealth National Parks

There are no Commonwealth National Parks within the Operational Area, Mixing Zone or Hydrocarbon Area. Christmas Island and Pulu Keeling National Park lie within the EMBA.

The Christmas Island National Park is 85km², with the marine zone consisting of water down to 50m in depth. The island is home to many protected endemic species such as the Christmas Island frigatebird and Abbott's booby bird. Around 80,000 seabirds nest on the island each year and the island is an important rookery for these birds (DAWE, 2014b). There is relatively low coral species diversity in the area because of the small size of the island and its isolation from coral larvae (88 species recorded), though the reefs are important for their isolation. Protected marine mammals also visit the island waters including the giant manta ray and whale sharks.

The Pulu Keeling National Park (otherwise known as the Cocos Islands) contains marine species that represent the western limit for many species of the Western Pacific biogeographic province (DAWE, 2014a). The marine reserve extends 1.5km offshore from the park, and protects 99 coral species, nine of which are not recorded anywhere else in the eastern Indian Ocean and two (one being of doubtful taxonomical class) are possibly endemic (DAWE, 2014a). The green turtle is known to nest on the beaches of the islands, and the hawksbill turtle is known to inhabit the waters of the park. Pulu Keeling National Park is also a designated Ramsar wetland (further details are provided in Section 4.6.7).

4.6.6 State Marine Protected Areas

4.6.6.1 Gazetted Marine Parks and Reserves

State Marine Protected Areas occur within State waters. There are 10 State marine protected areas within the EMBA, 9 of which are also in the Hydrocarbon Area. There are no State Marine Protected Areas within the Operational Area or Mixing Zone.

Table 4-25: State Marine Protected Areas within the Project Areas

State Marine Protected Areas	Operational Area & Mixing Zone	Hydrocarbon Area	EMBA
Barrow Island Marine Management Area		X	X
Barrow Island Marine Park		X	X
Eighty Mile Beach Marine Park		X	X
Jurien Bay Marine Park			X
Lalang-garram/Camden Sound Marine Park		X	X
Montebello Islands Marine Park		X	X
Muiron Islands Marine Management Area		X	X
Ningaloo Marine Park		X	X
Roebuck Bay Marine Park		X	X
Rowley Shoals Marine Park		X	X

X= present within area

The closest State marine parks and/or management areas are associated with the Montebello (72 km from the Operational Area) and Barrow Islands (85 km from the Operational Area).

The Montebello Islands/Barrow Island Marine Parks and Management Area display a complex seabed and island topography, with coastlines dominated by cliffs, beaches, sheltered lagoons and channels. As a result of this complexity, the reserves are characterised by a diverse range of habitats including subtidal coral reefs, macroalgal and seagrass communities, subtidal soft-bottom communities, rocky shores and intertidal reef platforms and mangrove communities (DEC, 2007a).

The parks provide important nesting and inter-nesting habitat for four of the six species of marine turtle found in WA, including flatback and green turtles, as well as being the northern limit for loggerhead turtle nesting (DEC, 2007a). Several species of whale have been recorded within the reserves. Humpback whales have been observed using the reserves as resting areas on their

annual migration (DEC, 2007a). Dugong are found in the vicinity of the Montebello Islands, Lowendal Islands and the Barrow Shoals where they feed on seagrass and algae (DEC, 2007a). In addition, the reserves are important rookeries for numerous species of seabirds.

Ningaloo Marine Park was declared in 1987 and the boundary was amended and gazetted again in November 2004 in conjunction with the gazettal of the Muiron Islands Marine Management Area (CALM, 2005).

The Ningaloo Marine Park covers an area of 263,343 hectares and protects a large portion of Ningaloo Reef, which stretches more than 300km from the North West Cape south to Red Bluff. It is the largest fringing coral reef in Australia, forming a discontinuous barrier enclosing a lagoon that varies in width from 200m to 7km. Gaps that regularly intercept the main reef line provide channels for water exchange with deeper, cooler waters (CALM, 2005). The Ningaloo Marine Park is part of the Ningaloo Coast WHA (see Section 4.6.1).

The Muiron Islands, located 15km northeast of North West Cape, comprise the North and South Muiron Islands. The Muiron Islands MMA covers an area of 28,616 hectares and occurs entirely within State waters (CALM, 2005). The Muiron Islands are structurally continuous with the Cape Range Peninsula but have a completely different geomorphic structure and marine environment when compared with the Ningaloo Reef. Muiron Island habitats include extensive mangrove and mudflats on the eastern shoreline, whereas the western shoreline is dominated by low limestone cliffs and rocky intertidal platforms with sandy beaches interspersed on the coast. Soft coral communities dominate the reefs on the western side of the islands and the east is rich in soft and hard corals (Cassata and Collins, 2008).

The Eighty Mile Beach Marine Park was created on 29 January 2013 and is located between Port Hedland and Broome covering an area of about 2,090km², stretching from Mulla Mulla Downs Creek in the southwest to Cape Missiessy in the northeast and encompassing all of Eighty Mile Beach. Eighty Mile Beach is an important feeding ground for migratory shorebirds and waders, and is listed as a Wetland of International Importance under the Ramsar Convention. It also supports a significant nesting population of flatback turtles. The marine park is rich in other marine life including sawfish, dugong and dolphins. Important marine and intertidal habitats in the proposed park include sand and mudflats, seagrass meadows, coral reefs and mangroves (DEC, 2011).

The Rowley Shoals Marine Park comprises two reefs of the Rowley Shoals, namely Clerke and Imperieuse reefs. The third reef, Mermaid Reef, lies within the Commonwealth managed Mermaid Reef National Nature Reserve. The Rowley Shoals Marine Park is characterised by complex intertidal and subtidal reefs, a diverse marine fauna and high water quality. The marine park is located in the headwaters of the Leeuwin Current and is thought to provide a source of invertebrate and fish recruitment for reefs further south and as such is considered regionally important (DEC, 2007b).

Lalang-garram/Camden Sound Marine Park is an important humpback whale calving area. It is also provides important habitat for protected species including; Australian snubfin dolphin, Indo-Pacific humpback dolphin, dugong, turtles (leatherback, flatback, green hawksbill, loggerhead and Olive Ridley turtle), sawfish (green, freshwater, dwarf and narrow sawfish) and the speartooth shark. The tidal range in the marine park can exceed 10m and this has a strong influence on the habitats and marine life in the area. Important marine habitats in the park include soft substrates (mud and sand), hard substrates (rocky shores, platforms and shoals), coral reefs and mangroves (DEC, 2010a).

The Roebuck Bay Marine Park is located south of the town of Broome. The area is internationally important as a feeding ground and refuge for hundreds of thousands of migratory waders and is a designated Ramsar wetland. The reserve also has the largest known population of Australian snubfin dolphins in Australia (DPaW, 2014).

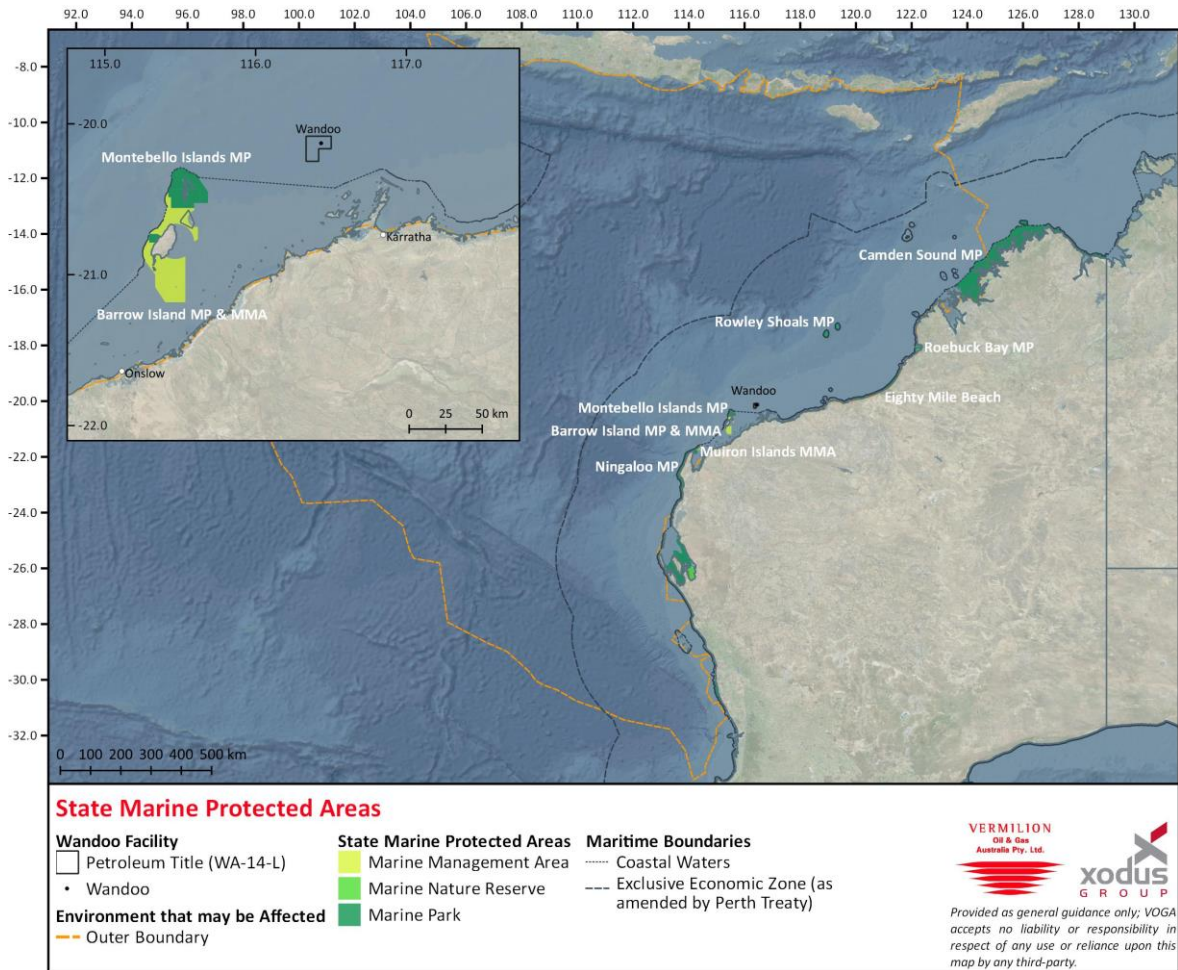

Figure 4-23: State Marine Protected Areas within the EMBA

4.6.6.2 Proposed marine park and management area

Dampier Archipelago Marine Park and Regnard Management Area (approximately 40km from Operational Area) have been proposed within the waters of the EMBA by the WA Government.

The proposed Dampier Archipelago Marine Park and Regnard Management Area is located off the coast of Dampier and includes the waters surrounding the 12 major islands and 30 smaller islands of the Dampier Archipelago. The marine fauna and flora consists primarily of tropical species, including many endemic species, with a particularly high diversity of infauna associated with the soft sediment habitats and a unique faunal assemblage associated with the coral reef habitats. In addition, a significant number of beaches are important turtle nesting sites and some of the islands support large seabird colonies.

The proposed Regnard Management Area would extend from Cape Preston to West Intercourse Island, approximately 25km southeast of Dampier, and includes the coastal waters and islands of Regnard Bay. The area has significant coral reef, mangrove and saltmarsh communities. The

proposed management area also supports populations of dugong. It is an important resting area for whales migrating along the WA coast and it is also a significant rookery for a variety of seabird species. Loggerhead, hawksbill and flatback turtles are known to nest on the area's sandy beaches (DPaW, 2014).

4.6.6.3 Indonesian National Parks

Indonesia contains a number of national parks located on the southern coastline of its islands and are used to protect a number of protected marine fauna. The Alas Purwo National Park on the south-eastern tip of East Java province is a peninsula containing important nesting beaches for the Olive Ridley, hawksbill and green turtle (Suwelo, 1999; Iqomah, 2004). Protected migratory birds can also be found in the park, such as the common sandpiper. The marine waters of the park also protect coral reefs and associated fauna (UNEP/IUCN, 1988).

The Meru Betiri National Park is located approximately 70km west of the Alas Purwo National Park, on East Java. It contains a small marine area (8.45km²) that supports the conservation of the leatherback, hawksbill, green and Olive Ridley turtle through protection of nesting beaches (Kuta Beach Sea Turtle Conservation, 2014).

4.6.7 Wetlands of international importance (Ramsar wetlands)

Ramsar wetlands are recognised as a matter of national environmental significance under the EPBC Act. There are six Ramsar wetlands within the EMBA; two of these also occur within the Hydrocarbon Area (Table 4-26). There are no Ramsar wetlands in the Operational Area or Mixing Zone.

Table 4-26: Wetlands of Importance within the Project Areas

Wetland	Operational Area & Mixing Zone	Hydrocarbon Area	EMBA
Ashmore reef national nature reserve			X
Eighty-mile beach		X	X
Hosnies spring (Christmas Island)			X
Pulu Keeling National Park (Cocos Island)			X
Roebuck bay		X	X
The Dales (Christmas Island)			X

X= present within area

Table 4-27: Summary of Ecological Character of Ramsar Wetlands

Ramsar Wetland
Ashmore Reef national nature reserve
Ashmore Reef Commonwealth Marine Reserve is located in the Indian Ocean on the edge of Australia's North West Shelf, 610 km north of Broome and 840 km west of Darwin. The Reserve is in Australia's External Territory of Ashmore and Cartier Islands. It is the largest of only three emergent oceanic reefs present within the north-eastern Indian Ocean. The Reserve is comprised of numerous marine habitats and supports a regionally important and diverse range of species.
The following summary of ecosystem components, processes and services has been extracted from Hale and Butcher 2013.
Ecosystem components and processes

- **Climate:** Arid tropical monsoonal climate. Located outside the main belt of tropical cyclones in the Timor Sea.
- **Geomprhic setting:** Located in an area of high oil and gas reserves, with active hydrocarbon seeps. Geomprhic groups within the site include reef slope, reef crest, reef flat, back reef sands, lagoons and islands.
- **Tides and currents:** Strong seasonal influences of the Indonesian Throughflow and Holloway currents. Internal waves are a feature of the region and Ashmore Reef may act to break these resulting in increased nutrients from the bottom waters. High energy environment with spring tides over 4.5 m and large flushing on tidal cycles.
- **Water quality:** Seasonal variations in temperature and salinity in ocean and lagoon water. Water calrity, turbidity and other water quality parameters remain a knowledge gap.
- **Vegetation:** Five species of seagrass recorded with *Thalassia hemprichii* dominant, comprising over 85% of total cover. Total cover of 470 ha, over 3,000 ha of macroalgae, mostly on reed slope and crest areas. Algae dominated by turf and coralline algae with fleshy macroalage comprising typically less than 10% of total algae cover.
- **Marine invertebrates:** Ashmore Reef has a diversity of marine invertebrates including hard and soft corals, molluscs, echinoderms and crustaceans. 275 species of hard coral, covering an area of around 700 ha. 39 taxa of soft coral, covering an area of around 300 ha. Total coral cover was low around the time of listing following the 1998 bleaching event but recovered in recent years to baseline levels. Over 600 species of mollusc, including two endemic species. Over 180 species of echinoderm, including 18 species of sea cucumber. Sea cucumber density is highly variable, but on average exceeds 30 per hectare. 99 species of decapod crustacean.
- **Fish:** Over 750 species of fish, including five species of fish and three species of shark listed as threatened. Predominantly shallow water, benthic taxa that are common throughout the Indo-Pacific. Density of small reef fishes is around 20,000 to 40,000 per hectare. Low density of sharks (less than one per hectare).
- **Sea snakes:** Prior to listing there was a high diversity and population, peaking in 1998 with an estimated total population of 40,000 snakes in the site. However, by time of listing in 2002 the site was on a trajectory of decline and diversity and abundance was low.
- **Turtles:** Three species of marine turtle: green (*Chelonia mydas*), hawksbill (*Eretmochelyis imbricata*) and loggerhead (*Caretta caretta*) all of which are listed threatened species. Green turtles are the most abundant, with a total estimated population of around 10,000. Nesting by two species; green turtles and hawksbill turtles.
- **Seabirds and shorebirds:** Ashmore Reef supports an abundance and diversity of wetland birds. 72 species of wetland dependent bird recorded within the Ramsar site. 47 species listed under international migratory agreements. Average of around 48,000 seabirds and shorebirds annually. Six species are regularly recorded in numbers greater >1% of the population. Nesting of 20 species, 14 of which regularly breed in the site.
- **Dugong:** Small but significant population, that may breed within the site. Data deficient.

Ecosystem services

- **Provisioning services–Freshwater:** Indonesian fishers use the freshwater lens at West Island.
- **Cultural services–Recreation and tourism:** Although remote and access is controlled, the site is important for passive recreation such as diving and bird watching.
- **Cultural services–Cultural heritage and identity:** Ashmore Reef has been regularly visited and fished by Indonesians since the early 18th century. West Island contains some archaeological artefacts and graves.
- **Cultural services–Scientific and educational:** The reef has high value for scientific research because it currently received relatively low use and is ecologically unique within the bioregion.
- **Supporting services–Near-natural wetland types:** Ashmore Reef supports a number of largely unmodified wetland types.

- **Supporting services–Biodiversity:** Ashmore Reef is a hotspot of biodiversity within the Timor Province bioregion. Highest biodiversity of reef building corals (275 species from 56 genera). Highest diversity of soft corals (39 taxa). More than 600 species of mollusc. Over 180 species of echinoderm, including 13 species of sea cucumber. Nearly 100 species of decapod crustacean. Over 750 species of finfish. High diversity of sea snakes.
- **Supporting services–Physical habitat:** The site supports large breeding colonies of seabirds.
- **Supporting services–Priority wetland species:** The Ramsar site supports 47 species of shorebirds listed under international migratory bird treaties.
- **Supporting services–Threatened species:** Ashmore Reef supports 62 species listed as threatened at the national and/or international level.

Eighty-mile Beach

Eighty-mile Beach is a large (220 km) linear sand coast. The boundary of the Ramsar site along the beach is defined by the tide, extending from Mean Low Water to 40 m above Mean High Water. The intertidal zone is comprised of a large expanse of intertidal mudflats (up to 4 km wide at the lowest tides) and a narrow strip at the landward edge of coarser quartz sands. The site is bounded by coastal dunes to the east. The discontinuous linear floodplain immediately inland of the frontal sand dunes, are predominantly outside the Ramsar boundary.

The following summary of ecosystem components, processes and services has been extracted from Hale and Butcher 2009.

Ecosystem components and processes

- **Climate:** Semi-arid monsoonal with a prolonged dry period, >80% of rainfall in the wet season (December to March). High inter-annual variability. High occurrence of tropical cyclones.
- **The Beach:**
 - **Geomorphology:** Extensive intertidal mudflats comprised of fine-grained sediments. Site is backed by steep dunes comprised of calcareous sand.
 - **Hydrology:** Macro-tidal regime. No significant surface water inflows. Groundwater interactions unknown (knowledge gap).
 - **Primary production and nutrient cycling:** Data deficient, but organic material deposited from ocean currents driving the system through bacterial or microphytobenthos driven primary production.
 - **Invertebrates:** Large numbers and diversity of invertebrates within the intertidal mudflat areas.
 - **Fish:** Data deficient, but anecdotal evidence of marine fish (including sharks and rays) using inundated mudflats.
 - **Waterbirds:** Significant site for stop-over and feeding by migratory shorebirds. Regularly supports >200,000 shorebirds during summer and >20,000 during winter. High diversity with 97 species of waterbird recorded from the beach. Regularly supports >1% of the flyway population of 20 species.
 - **Marine turtles:** Significant breeding site for the Flatback Turtle.
- **Mandora Salt Marsh:**
 - **Geomorphology:** Wetland formation dominated by alluvial processes. Wetlands were once a part of an ancient estuary. Freshwater springs have been dated at 7,000 years old.
 - **Hydrology:** Walyarta, East Lake and the surrounding intermittently inundated paperbark thickets are inundated by rainfall and local runoff. Extensive inundation occurs following large cyclonic events. Salt Creek and the Mound springs are groundwater fed systems through the Broome Sandstone Aquifer.
 - **Water quality:** Most wetlands are alkaline reflecting the influence of soils and groundwater. Salinity is variable, mound springs are fresh, Salt Creek hyper-saline and Walyarta variable with inundation. Nutrient concentrations in groundwater and groundwater fed systems are high.

- **Primary production and nutrient cycling:** Data deficient. However, evidence of boom and bust cycle at Walyarta with seasonal inundation.
- **Vegetation:** Inland mangroves (*Avicennia marina*) lining Salt Creek are one of only two occurrences of inland mangroves in Australia. Paperbark thickets dominated by the saltwater paperbark (*Melaleuca alsoophila*) extend across the site on clay soils which retain moisture longer than the surrounding landscape. Samphire (*Tecticornia* spp.) occurs around the margins of the large lakes. Freshwater aquatic vegetation occurs at Walyarta when inundated and at the mound spring sites year-round.
- **Invertebrates:** Data limited, but potentially unique species.
- **Waterbirds:** Significant site for waterbirds and waterbird breeding, particularly during extensive inundation events. 66 waterbirds recorded. Supports >1% of the population of at least two species. Breeding recorded for at least 24 species.

Ecosystem services

- **Provisioning service–Freshwater:** The freshwater springs at Mandora Salt Marsh provide drinking water for livestock.
- **Provisioning service–Genetic resources:** Plausible, but as yet no documented uses.
- **Regulating service– Climate regulation:** Plausible, but data deficient.
- **Regulating service–Biological control of pests:** Evidence that many of the shorebirds feed on the adjacent pasture land and that the incidence of 2.88 million Oriental Pratincole coincided with locusts in almost plague proportions, upon which the birds fed.
- **Cultural Services–Recreation and tourism:** The beach portion of the site is important for recreational fishing, tourism, bird watching and shell collecting.
- **Cultural Services–Spiritual and inspirational:** Spiritually significant for the Karajarri and Nyangumarta and contain a number of specific culturally significant sites. The site has inspirational, aesthetic and existence values at regional, state and national levels.
- **Cultural Services–Scientific and educational:** Mandora Salt Marsh and Eighty-mile Beach have been the site of a number of significant scientific investigations. In addition, Eighty-mile Beach is a significant site for migratory shorebird monitoring and is currently part of the Shorebirds 2020 program.
- **Supporting services:** As evidenced by the listing of the Eighty-mile Beach Ramsar site as a wetland of international importance. The system provides a wide range of biodiversity related ecological services critical for the ecological character of the site including
 - containing a diversity of wetland types
 - supporting significant numbers of migratory shorebirds
 - supporting significant wetland bird breeding
 - supporting flatback turtle breeding.

Hosnies Spring (Christmas Island)

Christmas Island is an Australian External Territory located in the Indian Ocean approximately 2,800 km west of Darwin and 500 km south of Jakarta, Indonesia. The Island is approximately 13,500 ha in size, 63% of which is National Park, including two Ramsar wetlands: Hosnies Spring and The Dales. Christmas Island National Park is managed by Parks Australia.

Hosnies Spring is a small area of shallow freshwater streams and seepages, 20-45 m above sea-level on the shore terrace of the east coast of the island. The Ramsar site consists of a stand of two species of mangroves of the usually tidal genus *Bruguiera*. The Ramsar site includes surrounding terrestrial areas with rainforest grading to coastal scrub and includes an area of shoreline and coral reef.

The following summary of ecosystem components, processes and services has been extracted from Hale and Butcher 2010.

Ecosystem components and processes

- **Climate:** Warm tropical climatic zone. High rainfall (200 mm per year), warm to hot year-round.
- **Geomorphic setting:** Site is located within the shore terrace on an area of gravel overlying phosphoric soils. Spring is situated at the base of the inland cliffs where spring water flows over a limestone flowstone.
- **Water quality:** Limited information (two snap shot surveys only). Typical of limestone karst systems with alkaline conditions and relatively high concentrations of calcium. Trace elements and metals are all low. Nitrogen is predominantly in the form of nitrate. High concentrations of sulphate result in a sulphurous odour.
- **Hydrological regime:** Groundwater dominant. Source of Hosnies Spring is perched, unconfined aquifer that discharges where impermeable volcanic rocks are close to the surface. Flow rate is not known but expected to be low. Spring is perennial.
- **Mangroves:** Stand of mangroves from the genus *Bruguiera* covers the majority of the wetland. Comprises a range of size classes with evidence of active regeneration. A number of very large trees (large than typical for the species), with the largest tree measuring 82 cm diameter at breast height and exceeding 40 m. Between 300 and 600 trees in total (>2.5 cm diameter at breast height) and a density between 10 and 20 trees per 100 m².
- **Land Crabs:** Supports a large population of at least three species: red crabs (*Gecarcoidea natalis*); robber crabs (*Birgus latros*) and blue crabs (*Discoplax hirtipes*).

Ecosystem services

- **Cultural services—Recreation and tourism:** While the site is open to the public, tourism is not promoted at the site. Rather, the site is managed to provide a limited number of visitors an opportunity to visit a unique wetland that is largely undisturbed by humans.
- **Cultural services—Scientific and educational:** The unique nature of the site and the pristine condition, provide excellent opportunities for research.
- **Supporting services—Supports near-nature wetland types:** The spring at the Ramsar site is in near-natural condition and significant within the bioregion. It is the only area on Christmas Island that supports freshwater mangroves.
- **Supporting services—Biodiversity:** Supports a variety of wetland species, communities and habitats including marine, terrestrial and freshwater dependent species.
- **Supporting services—Food webs:** Interactions between land crabs and mangroves form an important food web at the site.
- **Supporting services—Distinct wetland species:** Blue crabs are reliant on the few permanent freshwater sites on Christmas Island (including Hosnies Spring) for reproduction, and for survival in the dry season.
- **Supporting services—Ecological connectivity:** Red crab migrate from the plateau to the ocean to breed each year.

Pulu Keeling National Park (Cocos Island)

The Pulu Keeling National Park Ramsar site is located in the Indian Ocean approximately 2900 km northwest of Perth and 900 km southwest of Christmas Island. The Cocos (Keeling) Islands are an Australian territory comprising 27 coral islands with a total land area of approximately 14 km². There are 26 islands in the southern atoll of which two, Home Island and West Island, are inhabited. North Keeling Island (the Ramsar site) is located 24 km to the north.

The following summary of ecosystem components, processes and services has been extracted from Hale 2010.

Ecosystem components and processes

- **Climate:** Warm tropical climatic zone. High rainfall (2000 mm per year). Warm to hot year-round.
- **Geomorphology:** Island comprises calcareous sand and rubble of coral origin. Reef crest surrounding island. Central lagoon of sand and muds with intertidal sandy area. Sandy beach on northern shores.

- **Hydrology:** No surface freshwater. Semi -diurnal tide of 1 to 1.5 metres. Hydrological connection between lagoon and Indian Ocean.
- **Water Quality:** Data deficient.
- **Vegetation:** Tall (30 metre) pisonia forest covers much of the island. Saltmarsh herblands and Octopus shrublands near the lagoon shores.
- **Seagrass:** Data deficient - seagrass (turtle grass) in the lagoon area.
- **Marine Invertebrates:** Diverse community of Indo-Pacific species. A number of species recorded in the site do not occur in the southern atoll including the coconut or robber crab (*Birgus latro*). A small number of red crab (*Gecarcoidea natalis*) are also present.
- **Fish:** Community predominantly of Indo-Pacific origin. Endemism is low, but a number of species are at the western extent of their range at Cocos Island and there is evidence of hybridisation.
- **Turtles:** Important foraging for the hawksbill turtle and breeding for the green turtle (both listed as vulnerable under the EPBC Act). The green turtle population is believed to be resident in the Cocos (Keeling) Islands.
- **Waterbirds:** 23 species of waterbird; 15 species recorded breeding. Significant numbers of red-footed booby (30 000 pairs annually). Large numbers of lesser and greater frigatebirds and common nobby. Cocos buff-banded rail is endemic and the Ramsar site has the only known population.

Ecosystem services

- **Cultural Service-Recreation and Tourism:** Although the site is remote and access is controlled, the site is important for passive recreation such as diving and bird watching.
- **Cultural Service-Cultural heritage:** Shipwreck of the Emden. ☐ Historical significance for the Cocos Malay people.
- **Cultural Service-Scientific and educational:** PKNP Ramsar site has been (and continues to be) used for long-term scientific studies. Examples include red-footed booby surveys; breeding and migration of turtles and reef health.
- **Supporting Services-Supports near-natural wetland types:** PKNP is regarded as one of the most pristine coral atolls in the Indian Ocean and supports a number of largely unmodified wetland types.
- **Supporting Services-Threatened Species:** The PKNP Ramsar site supports the following threatened species: the endangered Cocos buff-banded rail, and the vulnerable green turtle and hawksbill turtle.
- **Supporting Services-Biodiversity:** PKNP Ramsar site supports a number of species that are no longer present in the southern atoll, making it significant in the Cocos Island IMCRA Province. ☐ In addition, the site supports a diversity of fish and marine invertebrates, many at the extent of their ranges.
- **Supporting Services-Provides physical habitat for breeding waterbirds:** The site supports large colonial waterbird breeding of red-footed booby, lesser frigate bird and common nobby.

Roebuck Bay

The Roebuck Bay Ramsar site comprises 34,119 ha, mostly occupied by intertidal mudflats. Waters more than 6 m deep at low tide are excluded from the site, which stretches from Campsite (a location on the northern shore of Roebuck Bay) east of the town of Broome, to south of Sandy Point. The soft bottom intertidal mudflats of the northern and eastern shores of Roebuck Bay, and high tide roosts at Bush and Sandy Points are the most biologically significant parts of the site, which was listed for several reasons including, most notably, outstanding shorebird values.

The following summary of ecosystem components, processes and services has been extracted from Bennelongia 2009.

Ecosystem components and processes

- **Climate:** The climate of the Broome region is semi-arid, monsoonal with a distinct wet (October to February) and dry season (March to September). Cyclonic flooding during the summer wet season results in periodic inundation of Roebuck Plains and drainage of freshwater off the Plains and through the mangroves.

- **Ocean currents:** The Indonesian Flowthrough flows westwards from the Pacific to the Indian Ocean. This in turn provides a mass of warm water to the Leeuwin current off Western Australia as it sweeps south along the west coast and east along the south coast.
 - **Tidal variation:** Tides in the vicinity of Broome have a very large range (9.5 m), thus exchange through the Bay is high, tidal velocities are relatively high and large mudflats have developed.
 - **Geomorphology:** A mega scale irregular curved embayment that contains a wide expanse of intertidal mud and sand flats indented by microscale linear tidal creeks.
 - **Sediment structure:** Three main sediment provinces have been identified: northern sands province, eastern silt and clay province and southern sands province.
 - **Hydrology:** The Broome Sandstone contains the most utilised (Broome water supply) and hence most threatened groundwater resource in the Canning Basin. The Broome Sandstone is generally an unconfined aquifer recharged by direct infiltration from rainfall. The Broome sandstone will be discharging groundwater to the surface or subsurface at the margins of the Roebuck plains and tidal creek systems. There will also be deep submarine groundwater discharge occurring at or below the low tide mark and within Roebuck deeps. The Broome Sandstone will be discharging groundwater to the coupled Roebuck Bay/Roebuck Plains system from all landward directions. This may create freshwater dependant ecological niches which could be threatened by regional water use or pollution. Roebuck Plains produces large amounts of sheetwash into the bay after large cyclonic events or prolonged wet season rains. This will be an important vector for nutrients, organic carbon and freshwater into the bay.
 - **Water quality:** Water quality appears poor, with TP levels, although there is limited information available from similar marine systems for comparison. Consideration has been given to the impact of urban run-off into the marine ecosystem. Agricultural activities may influence water quality from rangeland run-off during flood events.
 - **Littoral vegetation:** Along the sea edge there are mangrove communities. Mangrove detritus is a major source of energy for animals in the mangal and, perhaps, some mudflat species. Behind the mangal is an extensive plain of saline grassland that rises to the pindan plains typical of the western desert. Samphire occurs in the wetter zones. On beach dunes spinifex dominates.
 - **Plankton and diatoms:** Stable isotopes of carbon and nitrogen have shown that plankton and diatoms are a major source of energy for shellfish in the Bay.
 - **Benthic invertebrates:** Roebuck Bay has one of the most diverse arrays of benthic invertebrate infauna for any intertidal ecosystem. Species numbers are dominated by polychaetes. There is a rich assemblage of bivalves that provide an important source of accessible food for shorebirds. The average density of macrobenthic fauna is around 1287 animals per square metre.
 - **Birds:** The bay provides important food resources and refuge for migrating arctic shorebirds. A total of 43 species of waterbirds are recorded for the Bay including 22 species listed in migratory bird agreements.
 - **Fish:** The mudflats and mangrove creeks are nurseries for at least 4 fish species, for commercial prawn species and for mud crabs
 - **Marine fauna:** Dugongs have been regular and important inhabitants of Roebuck Bay. Earlier records show evidence of Dugongs feeding on extensive seagrass beds in 1986. Loggerhead Turtles and Green Turtles regularly use the Ramsar site as a seasonal feeding area and as a transit area on migration. Flatback Turtles regularly nest in small numbers around Cape Villaret during the summer months.
- Ecosystem services**
- **Provisioning services–Wetland products:** Commercial and recreational fisheries for a number of species of fish, prawns and crabs. Aboriginal people continue to make extensive use of the Bay's natural resources.
 - **Regulating Services–Pollution control and detoxification:** No data
 - **Regulating Services–Climate regulation:** No data

- **Cultural service–Recreation and tourism:** Major tourism and bird-watching venue. Broome is an important destination for national and international tourism. Active recreational fishing and crabbing activities, boating, hovercraft.
- **Cultural services–Spiritual and inspirational:** Site has inspirational and aesthetic values that are both regional and nationally recognised through travel to Broome. Roebuck Bay is spiritually significant to Aboriginal people belonging to the Yawuru and Jukun groups and contains a number of specific culturally significant sites.
- **Cultural services–Scientific and educational:** Many scientific research programs, especially on shorebirds and mudflat invertebrates, have been based at Roebuck Bay. they have often involved Broome Bird Observatory, near Fall Point.
- **Supporting Services–Biodiversity:** Key location in global flyway for migratory waders. Nursery values for prawns and fish. Seagrass beds for Dugong.

The Dales (Christmas Island)

Christmas Island is an Australian External Territory located in the Indian Ocean approximately 2,800 km west of Darwin and 500 km south of Jakarta, Indonesia. The Island is approximately 13,500 ha in size and contains two Ramsar wetlands: The Dales and Hosnies Spring.

The Dales Ramsar site covers 583 ha and is located on the western coastline of Christmas Island. The western boundary of the Ramsar site extends 50 m seaward from the low water mark and incorporates part of the coast. The Dales are located within the Christmas Island National Park which is managed by Parks Australia. The Ramsar site has a near-pristine system of seven watercourses. The Dales includes permanent and perennial streams, permanent springs, and include the majority of surface water on the Island.

The following summary of ecosystem components, processes and services has been extracted from Butcher and Hale 2010.

Ecosystem components and processes

- **Climate:** Warm tropical climatic zone. High rainfall (2,000 mm per year); warm to hot year-round.
- **Geomorphic setting:** Site is located within the shore terrace on an area of gravel overlying phosphoric soils. Springs are situated at the base of the inland cliffs where spring water flows over a limestone flowstone. The island is a karstic landscape with key geomorphic features including the terrace formations, sea cliffs, and caves and other karst features such as tufa at Hugh's Dale.
- **Hydrology:** Karstic drainage system of groundwater and surface ephemeral stream flow post heavy rainfall events during the wet season. Spring outflow of groundwater at three of the Dales is permanent.
- **Water quality:** Limited site-specific data; information from one survey in 2003 for Hugh's Dale may provide baseline data for time of listing. Water quality is good, with higher concentrations of some trace metals and major ions compared to upstream reference sites, due to the presence of volcanic rocks and significant crab populations.
- **Terrestrial vegetation:** Limited site-specific data; descriptions of the vegetation are limited. General descriptions for vegetation associations indicate five major associations, with tall rainforest the dominant type.
- **Coral reef:** The coral reef is limited and dominated by abiotic habitat and hard corals of low diversity.
- **Fish:** Community predominantly of Indo-Pacific origin. Endemism is low, but a number of species are at the western extent of their range at Christmas Island and there is evidence of hybridisation. One endemic freshwater species recorded from the sit
- **Invertebrates (non-crabs):** The site supports a low diversity of benthic marine invertebrates, but may also support anchialine fauna although no site-specific data has been sourced to confirm this.

- **Land crabs:** All 20 species of land crab occur within the boundary of the site. The Dales provide a major migration pathway for crabs to and from the ocean during spawning. The site is important for blue crabs in particular.
- **Water birds:** Eleven waterbirds, including nine endemic species, one nationally listed vulnerable and one endangered species are found at the site. The site supports breeding seabirds including Abbott's booby and red-footed booby.

Ecosystem services

- **Cultural services–Recreation and tourism:** The Dales is a popular recreational area for both tourists and locals. Two timber board walks have been installed at No. 1 Dale and Hugh's Dale. The Dales is the most popular sightseeing destination on the island with the waterfall at Hugh's Dale being the greatest attraction.
- **Cultural services–science and education:** Parks Australia undertakes and supports a range of research programs across the National Park, many of which are directly relevant to The Dales. For example, research investigations include impacts of the yellow crazy ant, land crab ecology and the Abbott's booby.
- **Supporting services–food webs:** Crab spawning provides a rich food supply to marine biota including whale sharks. In addition, the land crabs play a significant role in the energy dynamics of the forest affecting seedling recruitment and ultimately the structure of the forest. The invasion of the yellow crazy ant has significantly affected trophic relationships on Christmas Island.
- **Supporting services–Provides physical habitat (for breeding waterbirds):** Terrestrial vegetation provides roosting and breeding sites for several species of waterbirds.
- **Supporting services–Biodiversity:** Supports a variety of wetland species, communities and habitats including marine, terrestrial and freshwater dependent species.
- **Supporting services–Special ecological, physical or geomorphic features:** Provides critical habitat for the blue crabs and freshwater crabs, provides examples of karst features such as tufa deposits at the Hugh's Dale waterfall, and possibly anchialine cave communities.
- **Supporting services–Distinct or unique wetland species:** Red crabs are considered keystone species on the island.
- **Supporting services–Threatened wetland species, habitats and ecosystems:** The Dales Ramsar site supports nesting sites for the endangered Abbott's booby. The Christmas Island frigatebird has also been recorded from the site.
- **Supporting services–Priority wetland services:** Christmas Island supports a number of vagrant species listed under various international agreements.
- **Supporting services–Supports near-natural wetland types:** Springs and karst systems are representative of the bioregion and considered in near natural condition at the time of listing.
- **Supporting services–Ecological connectivity:** The streams of The Dales provide critical migration pathways for downward migration of red, blue and robber crabs and return pathways for juvenile blue crabs in particular.

4.6.8 Key ecological features

KEFs have been identified through the marine bioregional planning process and are described as those parts of the marine ecosystem that are considered to be important for the biodiversity or ecosystem functioning and integrity of a Commonwealth Marine Area (DEWHA, 2008). Within the EMBA, 18 KEFs have been identified (Table 4-28, Figure 4-24).

The importance and values have been identified for each of the KEFs within the SPRAT database (DoEE, 2019) and are summarised in Table 4-29.

Table 4-28 Key ecological features within the Project Areas

Key Ecological Feature	Operational Area & Mixing Zone	Hydrocarbon Area	EMBA
Ancient coastline at 125 m depth contour		X	X
Ashmore Reef and Cartier Island and surrounding Commonwealth waters			X
Canyons linking the Argo Abyssal Plain with the Scott Plateau		X	X
Canyons linking the Cuvier Abyssal Plain and the Cape Range Peninsula		X	X
Commonwealth waters adjacent to Ningaloo Reef		X	X
Continental Slope Demersal Fish Communities		X	X
Exmouth Plateau		X	X
Glomar Shoals		X	X
Mermaid Reef and Commonwealth waters surrounding Rowley Shoals		X	X
Seringapatam Reef and Commonwealth waters in the Scott Reef complex			X
Wallaby Saddle		X	X
Ancient coastline at 90-120m depth			X
Commonwealth marine environment surrounding the Houtman Abrolhos Islands			X
Commonwealth marine environment within and adjacent to the west coast inshore lagoons			X
Meso-scale Eddies			X
Perth Canyon and adjacent shelf break, and other west coast canyons			X
Western demersal slope and associated fish		X	X
Western rock lobster			X

X= present within area

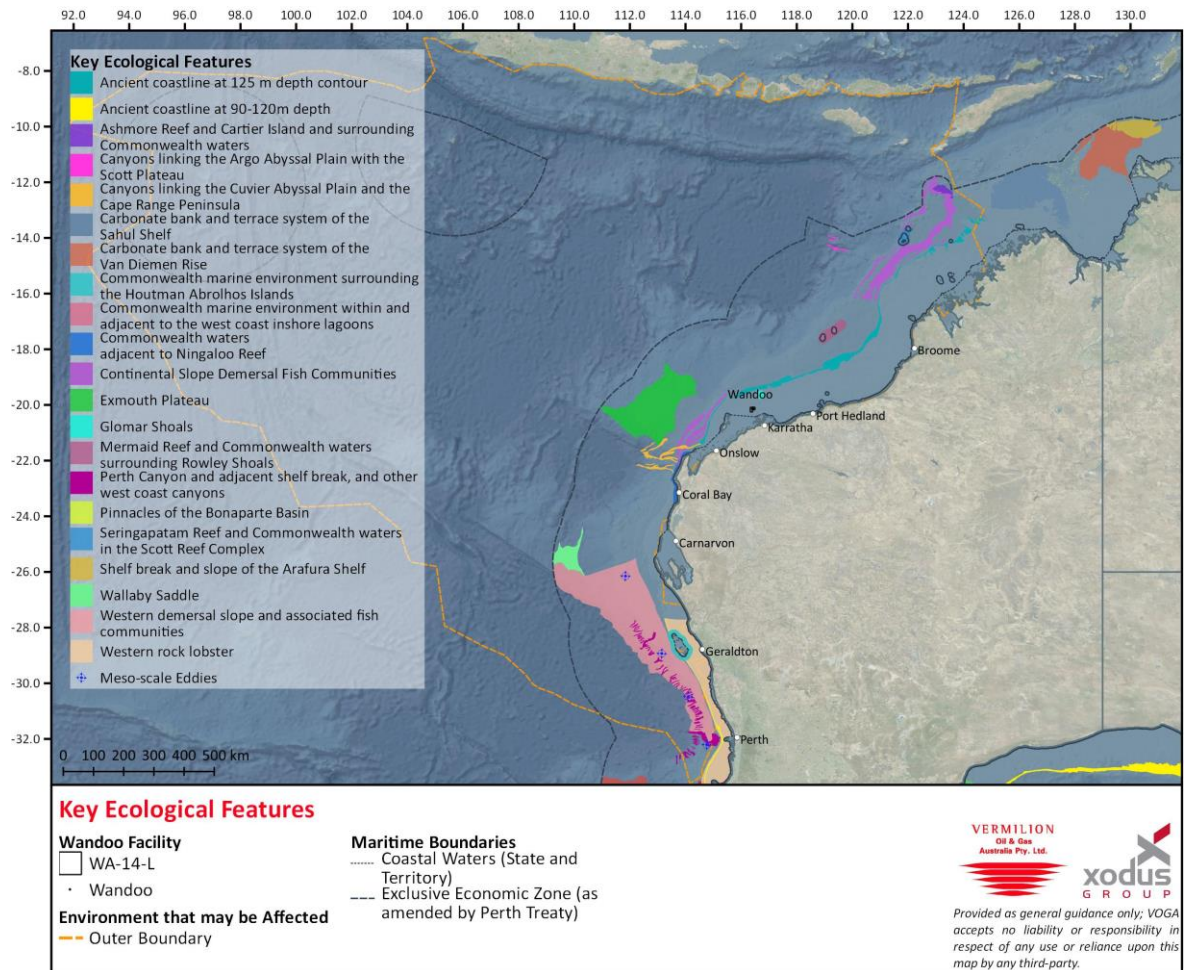

Figure 4-24: Key Ecological Features within the EMBA

Table 4-29: Importance and Values of Key Ecological Features

North-west Marine Region
Ancient coastline at 125 m depth contour
National and/or regional importance
The ancient coastline at 125 m depth contour is defined as a key ecological feature as it is a unique seafloor feature with ecological properties of regional significance.
Location
The shelf of the North-west Marine Region contains several terraces and steps which reflect changes in sea level that occurred over the last 100,000 years. The most prominent of these features occurs as an escarpment along the NWS and Sahul Shelf at a depth of 125 m. The spatial boundary of this KEF is defined by depth range 115–135 m in the Northwest Shelf Province and Northwest Shelf Transition IMCRA provincial bioregions.
Description and values
The ancient submerged coastline provides areas of hard substrate and therefore may provide sites for higher diversity and enhanced species richness relative to surrounding areas of predominantly soft sediment. Little is known about fauna associated with the hard substrate of the escarpment, but it is likely to include sponges, corals, crinoids, molluscs, echinoderms and other benthic invertebrates representative of hard substrate fauna in the NWS bioregion.
The escarpment may also facilitate increased availability of nutrients off the Pilbara by interacting with internal waves and enhancing vertical mixing of water layers. Enhanced productivity associated with the

sessile communities and increased nutrient availability may attract larger marine life such as whale sharks and large pelagic fish.

Humpback whales appear to migrate along the ancient coastline, using it as a guide to move through the region.

Ashmore Reef and Cartier Island and surrounding Commonwealth waters

National and/or regional importance

Ashmore Reef and Cartier Island and surrounding Commonwealth waters are defined as a key ecological feature for their high productivity, biodiversity and aggregations of marine life, which apply to both benthic and pelagic habitats.

Location

Ashmore Reef and Cartier Island are situated on the shallow upper slope of the Sahul Shelf. They form part of a series of submerged reef platforms along the outer edge of the continental slope of the North-west Marine Region.

Ashmore contains a large reef shelf, two large lagoons, several channelled carbonate sand flats, shifting sand cays, an extensive reef flat, three vegetated islands—East, Middle and West islands—and surrounding waters. Rising from a depth of more than 100 m, the reef platform is at the edge of the North West Shelf and covers an area of 239km². Ashmore Reef Commonwealth Marine Reserve encloses an area of about 583km² of seabed.

Cartier Island Commonwealth Marine Reserve (Cartier) is located in the West Sahul region of the Indian Ocean. The island is about 350 km off Australia's Kimberley coast, 115 km south of the Indonesian island of Roti and 45 km south-east of Ashmore Reef Commonwealth Marine Reserve. Cartier Island Commonwealth Marine Reserve covers 167 km² and contains one unvegetated sand cay and mature reef flat with two shallow pools to the north-east of the cay.

Description and values

Ashmore Reef is the largest of only three emergent oceanic reefs in the north-eastern Indian Ocean and is the only oceanic reef in the region with vegetated islands. Ashmore Reef supports the highest number of coral species of any reef off the Western Australian coast and provide varied habitat that attracts a diverse range of primary and secondary consumers, including a particularly diverse fish fauna. Toothed whales, dolphins and whale sharks are found in the Commonwealth waters around these reefs, as is a genetically distinct dugong population at Ashmore Reef.

The marine habitats among the reefs are nationally and internationally significant supporting diverse and abundant marine reptile populations. Both Ashmore and Cartier reefs support highly diverse and internationally significant sea snake populations. Ashmore Reef and Cartier Island also support a genetically distinct breeding population of green turtles and provide foraging grounds for this species as well as for loggerhead and hawksbill turtles. The reef system is an important staging post for seabirds and migratory shorebirds and the area is home to some of the most important seabird colonies in the North-west Marine Region. The importance of Ashmore Reef for seabirds and shorebirds is reflected in its listing as a Ramsar Wetland of International Importance in 2003.

Canyons linking the Argo Abyssal Plain with the Scott Plateau

National and/or regional importance

The Canyons linking the Argo Abyssal Plain with the Scott Plateau are defined as a KEF for their high productivity and aggregations of marine life. These values apply to both the benthic and pelagic habitats within the feature.

Location

The spatial boundary of this KEF includes the three canyons adjacent to the south-west corner of Scott Plateau. The Bowers and Oates canyons are the largest canyons connecting the Scott Plateau with the Argo Abyssal Plain; they are situated in the Timor Province (IMCRA provincial bioregion), west of Scott Reef.

Description and values

The Bowers and Oats canyons are major canyons on the slope between the Argo Abyssal Plain and Scott Plateau. The canyons cut deeply into the south-west margin of the Scott Plateau at a depth of approx. 2,000–3,000 m, and act as conduits for transport of sediments to depths of more than 5,500 m on the Argo Abyssal Plain. Benthic communities at these depths are likely to be dependent on particulate matter falling from the pelagic zone to the sea floor.

The water masses at these depths are deep Indian Ocean water on the Scott Plateau and Antarctic bottom water on the Argo Abyssal Plain; both water masses are cold, dense and nutrient-rich. The ocean above the canyons may be an area of moderately enhanced productivity, attracting aggregations of fish and higher-order consumers such as large predatory fish, sharks, toothed whales and dolphins.

The canyons linking the Argo Abyssal Plain and Scott Plateau are likely to be important features due to their historical association with sperm whale aggregations. Noting that the reasons for these historical aggregations of marine life remains unclear.

Canyons linking the Cuvier Abyssal Plain and the Cape Range Peninsula

National and/or regional importance

The Canyons linking the Cuvier Abyssal Plain and the Cape Range Peninsula are defined as a key ecological feature as they are unique seafloor features with ecological properties of regional significance, which apply to both the benthic and pelagic habitats within the feature.

Location

The largest canyons on the slope linking the Cuvier Abyssal Plain and Cape Range Peninsula are the Cape Range Canyon and Cloates Canyon which are located along the southerly edge of Exmouth Plateau adjacent to Ningaloo Reef. The canyons are unusual because their heads are close to the coast of North West Cape.

Description and values

The canyons on the slope of the Cuvier Abyssal Plain and Cape Range Peninsula are connected to the Commonwealth waters adjacent to Ningaloo Reef, and may also have connections to Exmouth Plateau. The canyons are thought to interact with the Leeuwin Current to produce eddies inside the heads of the canyons, resulting in waters from the Antarctic intermediate water mass being drawn into shallower depths and onto the shelf; these waters are cooler and richer in nutrients and strong internal tides may also aid upwelling at the canyon heads. The narrow shelf width (approx. 10km) near the canyons facilitates nutrient upwelling and this nutrient-rich water interacts with the Leeuwin Current at the canyon heads. Aggregations of whale sharks, manta rays, humpback whales, sea snakes, sharks, large predatory fish and seabirds are known to occur in this area and are related to productivity.

The canyons, Exmouth Plateau and Commonwealth waters adjacent to Ningaloo Reef operate as a system to create the conditions for enhanced productivity seen in this region.

Commonwealth waters adjacent to Ningaloo Reef

National and/or regional importance

The Commonwealth waters adjacent to Ningaloo Reef are defined as a KEF for their high productivity and aggregations of marine life, which apply to both the benthic and pelagic habitats.

Location

Ningaloo Reef extends >260km along Cape Range Peninsula with a landward lagoon 0.2–6km wide. Seaward of the reef crest, the reef drops gently to depths of 8–10 m; the waters reach 100 m depth, 5–6km beyond the reef edge. Commonwealth waters over the narrow shelf (10km at its narrowest) and shelf break are contiguous with Ningaloo Reef and connected via oceanographic and trophic cycling.

Description and values

Ningaloo reef is globally significant as the only extensive coral reef in the world that fringes the west coast of a continent; it is also globally significant as a seasonal aggregation site for whale sharks. The Commonwealth waters adjacent to Ningaloo Reef and associated canyons and plateau are interconnected

and support the high productivity and species richness of Ningaloo Reef. The Leeuwin and Ningaloo currents interact on the seaward side of the reef, leading to areas of enhanced productivity which support aggregations and migration pathways of whale sharks, manta rays, humpback whales, sea snakes, sharks, large predatory fish and seabirds. Detrital input from phytoplankton production in surface waters and from higher-trophic consumers cycles back to the deeper waters of the shelf and slope. Deepwater biodiversity includes fish, molluscs, sponges, soft corals and gorgonians. Some of these sponge and filter-feeding communities appear to be significantly different to those of the Dampier Archipelago and Abrolhos Islands, indicating that the Commonwealth waters of Ningaloo Marine Park have some areas of potentially high and unique sponge biodiversity.

The outer reef is marked by a well-developed spur and groove system of fingers of coral formations penetrating the ocean with coral sand channels in between. The spurs support coral growth, while the grooves experience strong scouring surges and tidal run-off and have little coral growth.

Continental slope demersal fish communities

National and/or regional importance

This species assemblage is recognised as a key ecological feature because of its biodiversity values, including high levels of endemism.

Location

This KEF is defined as the area of slope found in the Northwest Province and Timor Province provincial bioregions, at the depth ranges of 220-500 m and 750-1,000 m.

Description and values

The diversity of demersal fish assemblages on the continental slope in the Timor Province, the Northwest Transition and the Northwest Province is high compared to elsewhere along the Australian continental slope. The continental slope between North West Cape and the Montebello Trough has >500 fish species, 76 of which are endemic, which makes it the most diverse slope bioregion in Australia. The slope of the Timor Province and the Northwest Transition also contains >500 species of demersal fish of which 64 are considered endemic. The Timor Province and Northwest Transition bioregions are the second-richest areas for demersal fish across the entire continental slope.

The demersal fish species occupy two distinct demersal community types (biomes) associated with the upper slope (water depth of 225–500 m) and the mid-slope (750–1,000 m). Although poorly known, it is suggested that the demersal-slope communities rely on bacteria and detritus-based systems comprised of infauna and epifauna, which in turn become prey for a range of teleost fish, molluscs and crustaceans. Higher-order consumers may include carnivorous fish, deep-water sharks, large squid and toothed whales. Pelagic production is phytoplankton based, with hot spots around oceanic reefs and islands.

Bacteria and fauna present on the continental slope are the basis of the food web for demersal fish and higher-order consumers in this system. Loss of benthic habitat along the continental slope at depths known to support demersal fish communities may lead to a decline in species richness, diversity and endemism associated with this feature.

Exmouth Plateau

National and/or regional importance

The Exmouth Plateau is defined as KEF as it is a unique seafloor feature with ecological properties of regional significance, which apply to both the benthic and pelagic habitats.

Location

The Exmouth Plateau is located in the Northwest Province and covers an area of 49,310km² in water depths of 800–4,000 m.

Description and values

Although the seascapes of this plateau are not unique, it is believed that the large size of Exmouth Plateau and its expansive surface may modify deep-water flow and be associated with the generation of internal tides; both of these features may contribute to the upwelling of deeper, nutrient-rich waters closer to the

surface. The topography of the plateau (with valleys and channels), in addition to potentially constituting a range of benthic environments, may provide conduits for the movement of sediment and other material from the plateau surface through the deeper slope to the abyss.

The Exmouth Plateau is generally an area of low habitat heterogeneity; however, it is likely to be an important area of biodiversity as it provides an extended area offshore for communities adapted to depths of around 1,000 m. Sediments on the plateau suggest that biological communities include scavengers, benthic filter feeders and epifauna.

The plateau's surface is rough and undulating; the northern margin is steep and intersected by large canyons (e.g. Montebello and Swan canyons), the western margin is moderately steep and smooth and the southern margin is gently sloping and virtually free of canyons. Satellite observations suggest that productivity is enhanced along the northern and southern boundaries of the plateau and along the shelf edge, which in turn suggests that the plateau is a significant contributor to the productivity of the region.

Whaling records from the 19th century suggest that the Exmouth Plateau may have supported large populations of sperm whales.

Glomar Shoals

National and/or regional importance

The Glomar shoals are defined as a KEF for their high productivity and aggregations of marine life.

Location

The Glomar Shoals are a submerged littoral feature located approx. 150km north of Dampier on the Rowley Shelf at depths of 33–77 m.

Description and values

While the biodiversity associated with the Glomar Shoals has not been studied, the shoals are known to be an important area for a number of commercial and recreational fish species such as rankin cod, brown striped snapper, red emperor, crimson snapper, bream and yellow-spotted triggerfish. These species have recorded high catch rates associated with the Glomar Shoals, indicating that the shoals are likely to be an area of high productivity.

The shoals consist of a high percentage of marine-derived sediments with high carbonate content and gravels of weathered coralline algae and shells. The area's higher concentrations of coarse material in comparison to surrounding areas are indicative of a high-energy environment subject to strong sea-floor currents. Cyclones are also frequent in this area and stimulate periodic bursts of productivity as a result of increased vertical mixing.

Mermaid Reef and Commonwealth waters surrounding Rowley Shoals

National and/or regional importance

Mermaid Reef and Commonwealth waters surrounding Rowley Shoals is defined as a KEF for its enhanced productivity and high species richness, that apply to both the benthic and pelagic habitats.

Location

The Rowley Shoals are a collection of three atoll reefs (Clerke, Imperieuse and Mermaid) which are located approx. 300km northwest of Broome. The KEF encompasses Mermaid Reef MP as well as waters from 3–6 nm surrounding Clerke and Imperieuse reefs.

Mermaid Reef lies approx. 29km north of Clerke and Imperieuse reefs and is totally submerged at high tide. Mermaid Reef falls under Commonwealth jurisdiction; while the Clerke and Imperieuse reefs are within the Rowley Shoals Marine Park and under State jurisdiction.

Description and values

Mermaid Reef and Commonwealth waters surrounding Rowley Shoals are regionally important in supporting high species richness, higher productivity and aggregations of marine life associated with the adjoining reefs. The Rowley Shoals contain 214 coral species, approx. 530 species of fish, 264 species of molluscs and 82 species of echinoderms; no sea snakes are known to occur.

The reefs provide a distinctive biophysical environment in the region as there are few offshore reefs in the northwest. They have steep and distinct reef slopes and associated fish communities. Enhanced productivity is thought to be facilitated by the breaking of internal waves in the waters surrounding the reefs, causing mixing and resuspension of nutrients from water depths of 500–700 m into the photic zone. The steep changes in slope around the reef also attract a range of migratory pelagic species including dolphins, tuna, billfish and sharks.

Rowley Shoals' reefs are different from other reefs in the chain of reefs on the outer shelf of the North-west Marine Region, both in structure and genetic diversity. There is little connectivity between Rowley Shoals and other outer-shelf reefs. Both coral communities and fish assemblages of Rowley Shoals differ from similar habitats in eastern Australia. In evolutionary terms, the reefs may play a role in supplying coral and fish larvae to reefs further south via the southward flowing Indonesian Throughflow.

Seringapatam Reef and Commonwealth waters in the Scott Reef complex

National and/or regional importance

Seringapatam Reef and Commonwealth waters in the Scott Reef complex are defined as a KEF as they support diverse aggregations of marine life, have high primary productivity relative to other parts of the region, are relatively pristine and have high species richness, which apply to both the benthic and pelagic habitats.

Location

Scott and Seringapatam reefs are part of a series of submerged reef platforms that rise steeply from the sea floor between the 300–700 m depth on the northwest continental slope within the Timor Province. Scott and Seringapatam reefs provide an important biophysical environment in the region as one of few offshore reefs in the northwest.

Scott Reef consists of two separate reef formations, North Reef and South Reef. The KEF encompasses the waters beyond 3 nm at South Scott Reef and the reefs and surrounding waters at North Scott and Seringapatam reefs. The total area of the KEF is approximately 2,418km².

Description and values

Seringapatam Reef and Commonwealth waters in the Scott Reef complex are regionally important in supporting the diverse aggregations of marine life, high primary productivity and high species richness associated with the reefs themselves. As two of the few offshore reefs in the northwest, they provide an important biophysical environment in the region.

The coral communities at Scott and Seringapatam reefs play a key role in maintaining the species richness and subsequent aggregations of marine life. Scott Reef is a particularly biologically diverse system and includes >300 species of reef-building corals, approx. 400 mollusc species, 118 crustacean species, 117 echinoderm species and approx. 720 fish species. Corals and fish at Scott Reef have higher species diversity than the Rowley Shoals. Recent studies suggest that the capacity for coral dispersal between Scott Reef and other offshore reefs in the region may be limited.

Scott and Seringapatam reefs and the waters surrounding them attract aggregations of marine life including humpback whales (on their northerly migration) and numerous other cetacean species, whale sharks and several species of sea snake. Two species of marine turtle (green and hawksbill) nest during the summer months on Sandy Islet (South Scott Reef); the turtles also internest and forage in the surrounding waters. This KEF also provides foraging areas for seabird species such as the lesser frigatebird, wedge-tailed shearwater, brown booby and roseate tern.

Aggregations of marine life, high primary productivity and species richness on the reefs and in the surrounding Commonwealth waters are likely due to the steep rise of the reef from the seabed. This causes nutrient-rich waters from below the thermocline (approx. 100 m) to mix with the warmer, relatively nutrient-poor tropical surface waters via the action of internal waves and from mixing and higher productivity in the lee of emergent reefs.

Wallaby Saddle

National and/or regional importance

Wallaby saddle is defined as a KEF for its high productivity and aggregations of marine life; these values apply to both the benthic and pelagic habitats.

Location

The Wallaby Saddle covers 7,880km² of seabed and is an abyssal geomorphic feature that connects the northwest margin of the Wallaby Plateau with the margin of the Carnarvon Terrace on the upper continental slope at a depth of 4,000–4,700 m.

Description and values

The Wallaby Saddle is regionally important in that it represents almost the entire area of this type of geomorphic feature in the North-west Marine Region. The Wallaby Saddle is located within the Indian Ocean water mass and is thus differentiated from systems to the north that are dominated by transitional fronts or the Indonesian Throughflow. Little is known about the Wallaby Saddle; however, the area is considered one of enhanced productivity and low habitat diversity.

Historical sperm whale aggregations in the area of Wallaby Saddle may be attributable to higher productivity and aggregations of baitfish.

South-west Marine Region

Ancient coastline at 90–120 m depth

National and/or regional importance

The Ancient coastline between 90–120 m depth is defined as a key ecological feature for its potential high productivity and aggregations of marine life, biodiversity and endemism. Both benthic habitats and associated demersal communities are of conservation value.

Location

The continental shelf of the South-west Marine Region contains several terraces and steps. A prominent escarpment occurs close to the middle of the continental shelf at a depth of approximately 90–120 m.

Description and values

The continental shelf of the South-west Marine Region contains several terraces and steps which reflect the gradual increase in sea level across the shelf that occurred over the past 12,000 years. Some of these occur as escarpments, although their elevation and distinctness vary throughout the region. Where they are prominent, they create topographic complexity; for example, through exposure of rocky substrates that may facilitate small, localised upwellings, benthic biodiversity and enhanced biological productivity. While the ancient coastline is present throughout the region, it is particularly evident in the Great Australian Bight, where it provides complex habitat for a number of species.

Parts of this ancient coastline may support some demersal fish species travelling across the continental shelf to the upper continental slope, thereby supporting ecological connectivity. Benthic biodiversity and productivity occur where the ancient coastline forms a prominent escarpment of exposed hard substrates.

Commonwealth marine environment surrounding the Houtman Abrolhos Islands

National and/or regional importance

The Commonwealth marine environment surrounding the Houtman Abrolhos Islands (and adjacent shelf break) is defined as a KEF for its high levels of biodiversity and endemism in benthic and pelagic habitats.

Location

The Houtman Abrolhos Islands are a complex of 122 islands and reefs located at the edge of the continental shelf, approx. 60 km offshore from the Mid-West coast of WA.

Description and values

The Houtman Abrolhos waters and reefs are noted for their high biodiversity and mix of temperate and tropical species, resulting from the southward transport of species by the Leeuwin Current over thousands of years. The area represents the southern limit in WA of many widespread Indo-Pacific tropical fish. The

islands are the largest seabird breeding station in the eastern Indian Ocean, supporting more than one million pairs of breeding seabirds, including sedentary and migratory species. Many of the islands' biodiversity features rely on the benthic and pelagic ecosystems in deeper, offshore waters; most notably, seabirds and rock lobster.

The Houtman Abrolhos Islands lie in a transitional zone between major marine biogeographic provinces: the warm, tropical water of the Leeuwin Current and colder water more typical of the islands' latitude. The Leeuwin Current allows the Houtman Abrolhos Islands to support the highest-latitude coral reefs in the Indian Ocean. The reefs are composed of 184 known species of coral that support approx. 400 species of demersal fish, 492 species of molluscs, 110 species of sponges, 172 species of echinoderms and 234 species of benthic algae. In addition, the area provides important habitat for rock lobsters (*Panulirus cygnus*). The surrounding Commonwealth marine environment is also recognised as an important resting area for migrating humpback whales. The islands are the northernmost breeding site of the Australian sea lion, although sea lions are not thought to be an important component of this ecosystem because of their low population numbers.

Commonwealth marine environment within and adjacent to the west coast inshore lagoons

National and/or regional importance

The Commonwealth marine environment within and adjacent to the west-coast inshore lagoons is defined as a KEF for its high productivity and aggregations of marine life. Both benthic and pelagic habitats within the feature are of conservation value.

Location

The spatial boundary of this KEF is based on waters <30 m depth, in Commonwealth waters, from Kalbarri to slightly south of Mandurah.

Description and values

A chain of inshore lagoons extends along the WA coast from south of Mandurah to Kalbarri. The lagoons are formed by distinct ridges of north-south oriented limestone reef with extensive beds of macroalgae (principally *Ecklonia* spp.) and extend to a depth of 30 m. Although macroalgae and seagrass appear to be the primary source of production, it is suggested that groundwater enrichment may supplement the supply of nutrients to the lagoons. Seagrass provides important habitat for many marine species, and epiphytes are the main food source in the lagoonal system.

The lagoons are associated with high biodiversity and endemism, containing a mix of tropical, subtropical and temperate flora and fauna. The area includes breeding and nursery aggregations for many temperate and tropical marine species. They are important areas for the recruitment of commercially and recreationally important fishery species; extensive schools of migratory fish visit the area annually, including herring, garfish, tailor and Australian salmon.

The mix of sheltered and exposed seabeds form a complex mosaic of habitats. The inshore lagoons are important areas for the recruitment of western rock lobster, dhufish, pink snapper, breaksea cod, baldchin and blue gropers, abalone and many other reef species.

Meso-scale eddies

National and/or regional importance

Meso-scale eddies are defined as pelagic KEF for their high productivity and aggregations of marine life.

Location

Eddies and eddy fields form at predictable locations off the western and south-western shelf break: southwest of Shark Bay; offshore of the Houtman Abrolhos Islands; southwest of Jurien Bay; Perth Canyon; southwest of Cape Leeuwin; and south of Albany, Esperance and the Eyre Peninsula.

Description and values

Driven by interactions between currents and bathymetry, persistent meso-scale eddies form regularly (three to nine eddies per year) within the meanders of the Leeuwin Current. These features range between 50-200km in diameter and typically last more than five months.

Meso-scale eddies are important food sources, particularly for mesozooplankton, given the broader region's nutrient-poor conditions, and they become prey hotspots for a complex range of higher trophic-level species. Meso-scale eddies and seasonal upwellings have a significant impact on the regional production patterns.

The meso-scale eddies of this region are important transporters of nutrients and plankton communities, taking them far offshore into the Indian Ocean, where they are consumed by oceanic communities. They are likely to attract a range of organisms from the higher trophic levels, such as marine mammals, seabirds, tuna and billfish. The eddies play a critical role in determining species distribution, as they influence the southerly range boundaries of tropical and subtropical species, the transport of coastal phytoplankton communities offshore and recruitment to fisheries.

Perth Canyon and adjacent shelf break, and other west coast canyons

National and/or regional importance

The Perth Canyon forms a major biogeographical boundary and it is defined as a KEF because it is an area of higher productivity that attracts feeding aggregations of deep-diving mammals and large predatory fish. It is also recognised as a unique seafloor feature with ecological properties of regional significance.

Location

The west coast system of canyons spans an extensive area (8,744km²) of continental slope offshore from Kalbarri to south of Perth. It includes the Geographe, Busselton, Pelsaert, Geraldton, Wallaby, Houtman and Murchison canyons and, most notably, the Perth Canyon (offshore of Rottnest Island), which is Australia's largest ocean canyon.

Description and values

The Perth Canyon is prominent among the west coast canyons because of its magnitude and ecological importance; however, the sheer abundance of canyons spread over a broad latitudinal range makes this feature important.

In the Perth Canyon, interactions between the canyon topography and the Leeuwin Current induce clockwise-rotating eddies that transport nutrients upwards in the water column from greater depths. Due to the canyon's depth and the Leeuwin Current's barrier effect, this remains a subsurface upwelling (depths >400 m), which confers ecological complexity that is typically absent from canyon systems in other areas. The Perth Canyon also marks the southern boundary for numerous tropical species groups on the shelf, including sponges, corals, decapods and xanthid crabs.

The Perth Canyon marks the southern boundary of the Central Western Province. Deep ocean currents upwelling in the canyon create a nutrient-rich, cold-water habitat that attracts deep-diving mammals and large predatory fish, which feed on small fish, krill and squid. A number of cetaceans, predominantly pygmy blue whales, aggregate in the canyon during summer to feed on the prey aggregations. Arriving from November onwards, their numbers peak in March to May. The topographical complexity of the canyon is also believed to provide more varied habitat that supports higher levels of epibenthic biodiversity than adjacent shelf areas.

Western demersal slope and associated fish communities

National and/or regional importance

The demersal slope and associated fish communities are recognised as a KEF for their high levels of biodiversity and endemism.

Location

This KEF extends from the edge of the shelf to the limit of the exclusive economic zone, between Perth and the northern boundary of the South-west Marine Region.

Description and values

The western continental slope provides important habitat for demersal fish communities. In particular, the continental slope of the Central Western provincial bioregion supports demersal fish communities characterised by high diversity compared with other, more intensively sampled, oceanic regions of the world. Its diversity is attributed to the overlap of ancient and extensive Indo-west Pacific and temperate Australasian fauna. Approx. 480 species of demersal fish inhabit the slope of this bioregion, and 31 of these are considered endemic to the bioregion.

A diverse assemblage of demersal fish species below a depth of 400 m is dominated by relatively small benthic species such as grenadiers, dogfish and cucumber fish. Unlike other slope fish communities in Australia, many of these species display unique physical adaptations to feed on the seafloor (such as a mouth position adapted to bottom feeding), and many do not appear to migrate vertically in their daily feeding habits.

Western rock lobster

National and/or regional importance

The Western rock lobster is defined as a KEF due to its presumed ecological role on the west coast continental shelf.

Location

The spatial boundary of this KEF includes Commonwealth waters in the South-west Marine Region, to a depth of 150 m, north of Cape Leeuwin.

Description and values

Western rock lobster (*Panulirus cygnus*) is the dominant large benthic invertebrate in this bioregion, and can be found north of Cape Leeuwin to a depth of 150 m. It is also an important part of the food web on the inner shelf, particularly as a juvenile, when it is preyed upon by octopus, cuttlefish, baldchin groper, blue groper, dhufish, pink snapper, wirrah cod and breaksea cod. Western rock lobsters are also particularly vulnerable to predation during seasonal moults in November–December and to a lesser extent during April–May. The high biomass of western rock lobsters and their vulnerability to predation suggest that they are an important trophic pathway for a range of inshore species that prey upon juvenile lobsters.

As an abundant and wide-ranging consumer, the western rock lobster is likely to play an important role in ecosystem processes on the shelf waters in the region. The ecological role of western rock lobster is best understood in shallow waters (<10 m) where it can significantly reduce the densities of invertebrate prey, such as epifaunal gastropods, through its varied and highly adaptable diet. However, there is a lack of similar studies in deeper water (>20 m). The little information available for deep-water populations suggests that lobsters forage primarily on animal prey, which is dominated by crustaceans such as decapod crabs and amphipods.

4.6.9 Threatened Ecological Communities

The EPBC Act provides for the listing of threatened ecological communities (TECs), and these are considered as MNES under the EPBC Act. Threatened Ecological Communities (TECs) provide wildlife corridors or refuges for many plant and animal species. Ecological communities are listed as threatened if the community is presumed to be totally destroyed or at risk or becoming totally

destroyed. The following marine/coastal TECs were identified within the EMBA and Hydrocarbon Area:

- Monsoon vine thickets on the coastal sand dunes of Dampier Peninsula.
- There are no TECs within the Operational Area or Mixing Zone.

The Monsoon vine thickets on the coastal sand dunes of Dampier Peninsula ecological community represents certain occurrences of monsoon vine thickets in the southwest Kimberley region of Western Australia. The ecological community is predominantly restricted to the coast of the Dampier Peninsula (Figure 4-25) and represents the most southern occurrences of rainforest type vegetation in Western Australia.

The Dampier Monsoon Vine Thickets occurs as discontinuous patches of dense vegetation and contains approximately 23% of vascular plant species that occur on the Dampier Peninsula. Dampier Monsoon Vine Thickets are considered a rainforest subset ranging from semi-deciduous vine thickets to closed semi-deciduous vine forest. The ecological community provides an important habitat for a number of plant species. For example, the vine *Parsonsia kimberleyensis* is at the southern-most limit of its range within the ecological community along with *Glycosmis* sp. and the deciduous shrub *Croton habrophyllus* (Kenneally *et al.*, 1996). The small tree, *Vitex glabrata* (bush currant) is only known to occur on the Dampier Peninsula in the ecological community (Black *et al.*, 2010).

Compared to the adjacent open vegetation occurring over the majority of the Dampier Peninsula, the relatively dense, closed canopy of the Dampier Monsoon Vine Thickets provides a shady and humid microclimate. This relatively moist environment provides refuge for animals particularly during the dry season when fires in the landscape are more frequent (Johnstone and Burbidge, 1991; Kendrick and Rolf, 1991; Price, 2004). The abundance of fruiting plants within the ecological community also provides relatively rich food resources for many taxa. No fauna are known to be endemic to the ecological community on a national scale, but some species are endemic at a regional level and many species occur both in the ecological community and surrounding vegetation types.

The Dampier Monsoon Vine Thickets contains habitat for at least four threatened fauna species listed under the EPBC Act and at least five threatened flora species listed under the WA Biodiversity Conservation Act 2016. The National Heritage listing of West Kimberley overlaps within the northern end of the Dampier Peninsula; however, the Dampier Monsoon Vine Thicket patches are not part of the Heritage listed area. (DSEWPac, 2013o)

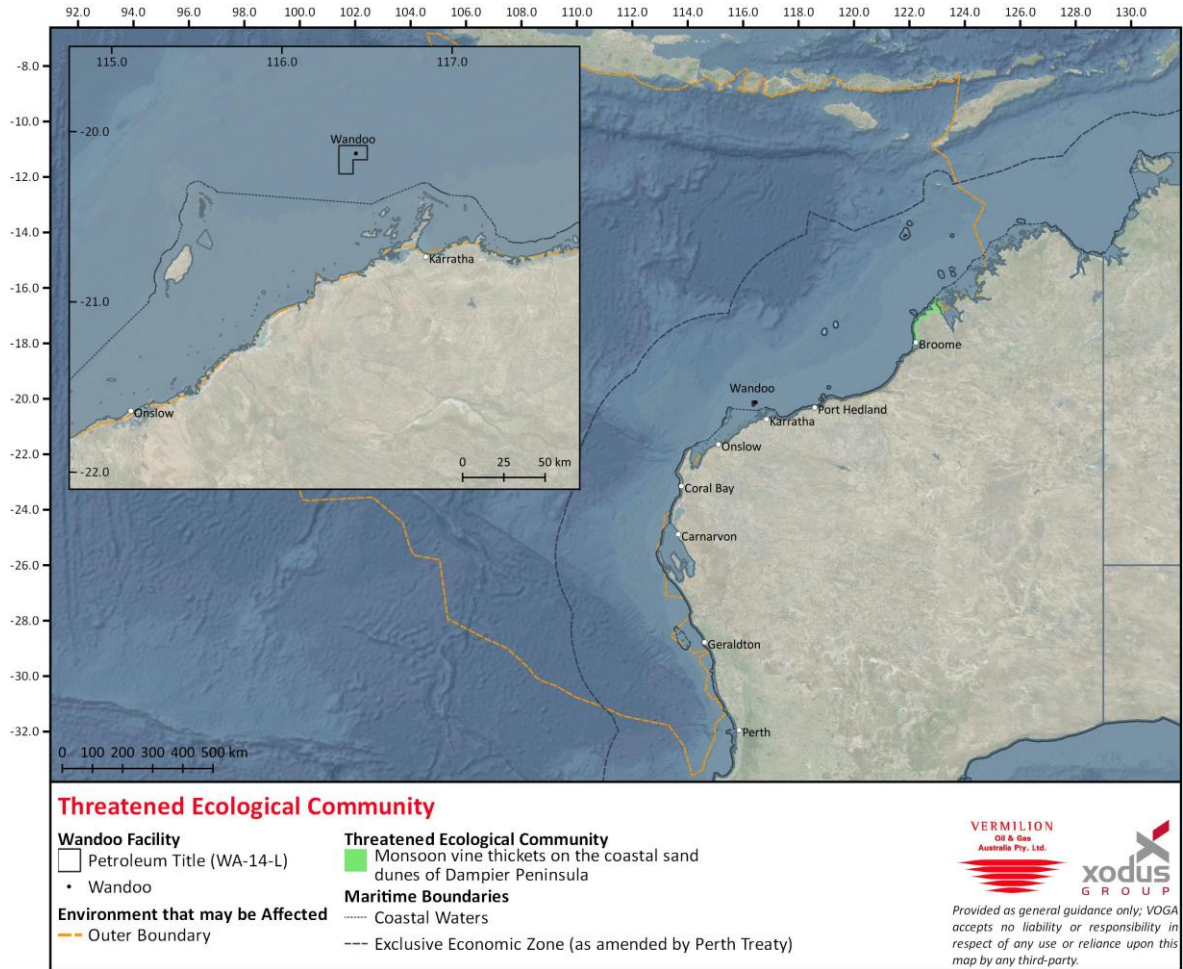

Figure 4-25: Marine/Coastal TECs present within the EMBA

5. Risk assessment methodology

5.1 Overview

Environmental risk assessment is a key component of the environmental risk management process. Environmental risk is assessed by determining the consequence (impact) of an environmental hazard and the likelihood that the consequence will occur, taking consideration of both existing and additional proposed control measures.

Key terminology used in this section of the EP includes:

Acceptable: a tolerable level of impact or risk (either quantitative or qualitative) when assessed in relation to the principles of Ecological Sustainable Development (ESD), internal and external contextual consideration and other relevant requirements (Section 5.8).

Activity: An activity is a 'Petroleum Activity' as defined within sub-regulation 59C of the Offshore Petroleum and Greenhouse Gas Storage (Regulatory Levies) Regulations 2004. Specifically, in the context of this Wandoo Facility EP, 'Activity' relates to Wandoo 'Operational' activities

ALARP: A level of risk that is tolerable, where the cost of reducing it further (e.g. financial, time, effort) is grossly disproportionate to any risk reduction gained (as per VOGA Risk Management Manual VOG-2000-MN-0001). The methodology for demonstrating ALARP is described in further detail below (Section 5.5);

Catastrophic Environmental Event (CEE): any event which has an environmental impact ranked as "5 – Catastrophic" on the VOGA risk matrix (Section 5.3).

Cause: The cause of an environmental impact. The cause may be an 'activity', or the cause could be an accidental event, e.g. "vessel collision with facility";

Consequence ranking: A measure of the severity of the environmental impact in accordance with the VOGA risk matrix (Section 5.3);

Control: A means of reducing environmental risk by prevention, frequency reduction, or impact reduction. Controls take many forms including systems, procedures, people and equipment;

Critical Control: a control that has a key role in preventing, detecting, controlling or mitigating a CEE (as assessed on the VOGA risk matrix);

Environment: is and includes the social, economic and cultural features of:

- ecosystems and their constituent parts, including people and communities; and
- environmental assets such as:
 - natural and physical resources;
 - the qualities and characteristics of locations, places and areas; and
 - the heritage value of places.

Environmental hazard: A situation with the potential for causing an environmental impact;

Environmental impact: Any change to the environment arising from an environmental hazard;

Likelihood ranking: A measure of the chance of an environmental impact occurring (expressed as an approximate frequency) in accordance with the VOGA risk matrix (Section 5.3);

Measurement criteria: Tangible indicators, quantifiable where possible, that will be used to evaluate the achievement (or otherwise) of environmental performance standards and outcomes;

Mitigation controls: Controls which will be utilised if the environmental hazard requires steps to be taken to return the activity and/or the environment to an acceptable state, i.e. consistent with the environmental outcome;

Performance outcome: A qualitative goal which summarises the objective of a control (or group of controls);

Performance standard: A statement of the performance required of a control;

Preventive controls: Controls which will prevent an environmental impact; and

Residual risk: The residual risk rating considering the effectiveness and availability of controls (existing and additional).

5.2 Framework

The environmental risk assessment was undertaken in accordance with VOGA Risk Management Manual [VOG-2000-MN-0001] and in line with the requirements of the OPGGS(E)R. The framework adopted by VOGA in compiling this EP is consistent with the methodology described in AS/NZS ISO 31000 and NOPSEMA Guidance [N04750-GN1344]. Figure 5-1 depicts this methodology with reference to relevant sections of this EP where the requirements are addressed.

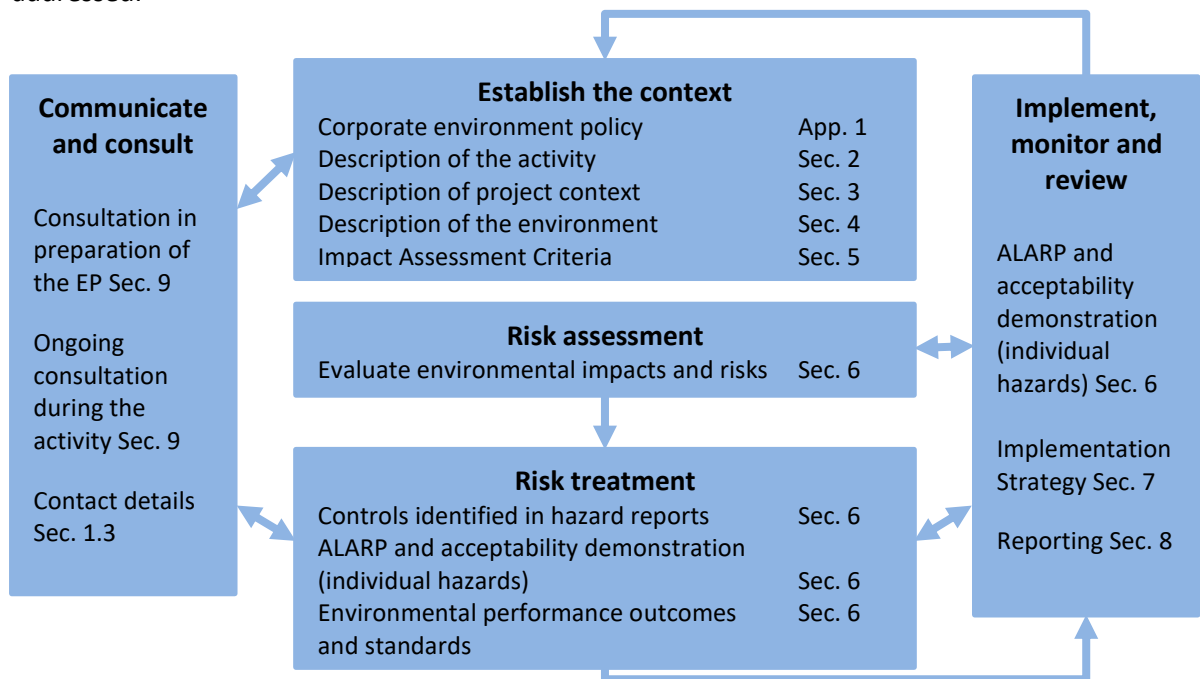

Figure 5-1: Content requirements of this EP (within the framework outlined in AS/NZS ISO 31000)

The scope of operations covered by this EP was confirmed in terms of its timing(s), extent, and the nature of the activities included within it. This scope is reflected in the activities described in Section 2.

Potential environmental hazards associated with activities and accidental events were identified, and impacts determined in a qualitative manner in an environmental hazard review workshop. Existing controls were identified in the same workshop. Each hazard employs a hierarchy of controls which relies on the following (in order of preference):

- Elimination: Refers to the elimination of a hazard, for example the use of a renewable energy source eliminates the emissions associated with power generation;
- Substitution: This refers to scenarios where an alternative arrangement is used to reduce the risk levels. For example, using a lower emission fuel type;
- Prevention: removing the causes of an impact or decrease their likelihood. As an example, a simpler plant with fewer leak points.
- Reduction: Limits the scale and consequence of an impact. For example, changes to process systems to reduce the size of hazardous inventories.
- Mitigation: Controls in place to respond to an incident, such as oil spill contingency planning.

In the case of complex or high hazard risks, environmental impact modelling was carried out to ensure that the impacts were thoroughly understood.

The severity, frequency, and subsequently the initial risk ranking was allocated to each hazard in accordance with the VOGA Risk Management Manual [VOG-2000-MN-0001]. The risk rankings were reviewed, and additional controls were considered to reduce the residual risk to ALARP.

The performance outcomes, performance standards and measurement criteria associated with the controls were developed in a series of performance standard workshops. The residual risk score for each environmental hazard was assigned considering the risk reduction from both the existing and additional controls. The implementation strategy (Section 7) describes how the additional controls will be implemented.

5.3 Impact assessment

An assessment of impact for each identified hazard was conducted by:

- Defining impact assessment criteria;
- Quantifying magnitude of the stressor, including where applicable, quantity, concentration of contaminant and level of disturbance;
- Consideration of timing and duration of the impact and other factors affecting the impact and risk (depth, temperature, tides, etc.);
- Consideration of environmental features affected either directly or indirectly; and
- Evaluation of the acceptability of the impact.

5.4 Catastrophic Environmental Events and Critical Controls

In the context of the Wandoo facilities, an event with a consequence ranking of Catastrophic (5) as per Table 5-1 is defined as a CEE. A physical control, measure or procedure that has a key role in preventing, detecting, controlling or mitigating a CEE is defined as a Critical Control. Although environmental performance outcomes are developed for all environmental controls, Critical Controls are subjected to more stringent management. Management of critical controls is discussed in the Implementation Strategy (Section 7).

5.4.1 Identifying Catastrophic Environmental Events

Environmental hazards for the Wandoo facilities are discussed in Section 6. It is important to note that there will usually be a range of possible impacts resultant from each hazard and only some of these may have catastrophic potential. The overview of all environmental hazards (Section 6.1) and each individual hazard report identify the worst credible impact resultant from each hazard.

Based on the description of the hazard and the range of possible impacts for each hazard in Section 6 it is possible to determine those circumstances where a release would have catastrophic potential. It is only under these circumstances that a CEE would result. These events have been designated as a CEE and a CEE-XX numerical designator allocated.

5.4.2 Identifying Critical Controls

Once an event has been identified as a CEE the controls associated with that event must be assessed to determine which controls are considered critical. To confirm the applicability of a control measure as critical, it is necessary to apply a reasoned process as depicted in Figure 5-2.

For identified CEEs in Section 6 the controls associated with those events have been subjected to the above process and Critical Controls identified. Critical Controls, where identified have been defined in the relevant hazard assessments in Section 6.

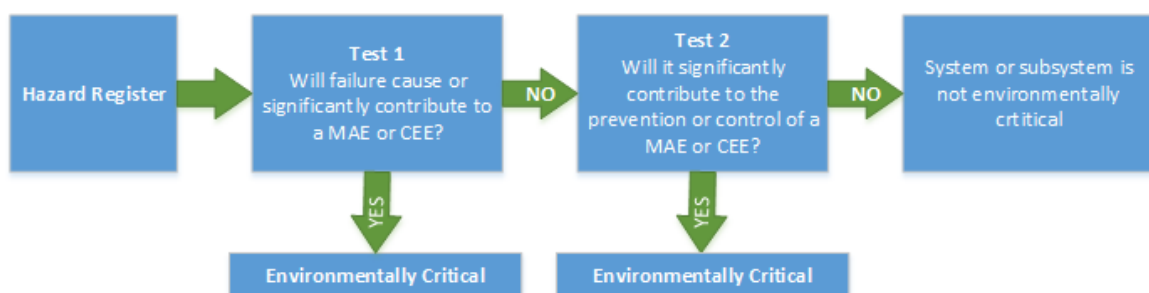

Figure 5-2: Critical Element identification process

5.5 Determination of Likelihood

The VOGA Environmental Risk Matrix (Table 5-1) provides for the likelihood of an impact (consequence) occurring to be determined on the basis of either chance, probability or frequency.

For higher-order impacts, the probability of the impact occurring should be evaluated (where possible) on industry data of previous events that have caused impacts to occur. Where statistical

industry data is not available, the frequency of events should be determined via other means such as corporate knowledge.

For lower-order impacts, or where historical industry information may be unavailable, either 'frequency' or chance' may be used to determine likelihood of the impact occurring.

The determination of likelihood should only be evaluated using a single evaluation technique i.e., either chance, probability or frequency.

5.6 VOGA risk ranking

The risk ranking was carried out in accordance with VOGA Risk Management Manual and utilised throughout Section 6.

Table 5-1 is the VOGA corporate risk matrix representing the environmental consequence evaluation in relation to the frequency rating of the occurrence of the environmental hazard, assuming identified controls are in place. The residual risk level is used to establish the actions required to manage potential impacts and risks to ALARP and acceptable levels, including the identification of critical controls; and provides Wandoo-specific supplementary environmental consequence definitions in the context of the nature of receptors potentially impacted by the petroleum activity as described in Section 2 of this EP.

VOGA considers residual environmental risks to be acceptable when at a Residual Risk (RR) level of RRIV (Low) or RRIII (Medium).

Table 5-1: VOGA Environmental Risk Matrix

			LIKELIHOOD					
			Chance	Rare	Unlikely	Possible	Likely	Almost Certain
			Probability	1 in 10 000 - 100 000 (10 ⁻⁵)	1 in 1 000 - 10 000 (10 ⁻⁴)	1 in 100 - 1 000 (10 ⁻³)	1 in 10 - 100 (10 ⁻²)	1 in 1-10 (10 ⁻¹)
			Frequency	Not known to have occurred, but believed to be a credible scenario	Has occurred within our own industry	Has occurred within Vermilion, or has occurred multiple times per year within our own industry	Has occurred several times within Vermilion	Has occurred typically once or more per year within Vermilion
			Environment	A	B	C	D	E
POTENTIAL CONSEQUENCE	Irreversible effects on habitat, ecological communities, land, air or water Persistent reduction in sensitive ecosystem function (extends beyond area abandonment timeframe) Effects extend beyond regional scale and/or operating area/district	5	Catastrophic					
	Persistent but reversible, long-term (>10 years) effects on habitat, ecological communities, land, air or water Effects are widespread within region and/or specific operating area	4	Major					
	Reversible, medium-term (5-10 years) effects on habitat, ecological communities, land, air or water Effects extend into the immediate surroundings of the operating area/lease and/or localized off-lease	3	Moderate					
	Reversible, short-term (1-5 years) effects on habitat, ecological communities, land, air or water Effect within operating area/lease boundaries or localized off-lease	2	Minor					
	Reversible, short-term (<1 year) effects on habitat, ecological communities, land, air or water Effect within operating area and/or contained on-lease	1	Incidental					

Table 5-2 Risk action table

Risk Level* (includes inherent risk in the event no safeguards are available)	Inherent Risk Action to Reduce Risk to an Acceptable Level	Residual Risk Action to Reduce Risk to an Acceptable Level
RRI or Extreme	Immediate implementation of temporary safeguard. Stop activities until risk controls/safeguards that will reduce the risk are implemented Implement permanent safeguard to reduce risk to acceptable level.	Review Environment Acceptability criteria (Section 5.8)
RRII or High	Immediate implementation of temporary safeguard. Establish a team for the: Evaluation of permanent safeguards, Implementation of permanent safeguards to reduce risk to an acceptable level.	
RRIII or Medium	Safeguards are re-evaluated to determine suitability and acceptability. Establish a team for the evaluation and maintenance of current safeguards. Evaluate for ALARP. Implement permanent safeguards or accept risk as per defined authority.	
RRIIV or Low	Controls are reviewed to ensure effectiveness. No further risk treatment if ALARP.	

Table 5-3: Wandoo-specific supplementary environmental consequence definitions

Term used	Definition in the context of this EP
Geographical extent of impact	
Regional scale	Extent of impact across multiple bioregional provinces (EMBA)
Widespread	Extent of impact beyond the Permit Area (<200 km)
Localised off lease	Extent of impact mostly within the Permit Area with some effect extending beyond the boundaries of the area (<40 km).
Within operating area	Extent of impact limited to the Operational Area and Mixing Zone
Socio-economic criteria: Environment criteria applies for impact and duration. Below are a range of examples for Socio-economic impacts and how they are applied to environment consequence ranking in the context of this EP	
5 Catastrophic	Widespread damage to or exclusion from commercial enterprise or collapse of commercial enterprise.
4 Major	Damage to or long-term exclusion (>10 years) from large proportion of commercial or recreational enterprise (e.g. fishery closure)
3 Moderate	Medium-term (5-10 years) damage to or temporary exclusion from large proportion of commercial or recreational enterprise where recovery is expected to occur within 1 year of the activity stopping

Term used	Definition in the context of this EP
2 Minor	Temporary or permanent exclusion to minor proportion of commercial or recreational enterprise.
1 Incidental	Very short-term exclusion to minor proportion of commercial or recreational enterprise; or community disturbance impact e.g. low-level noise, vibration, lighting.

5.7 Demonstrating ALARP of impact and risk

5.7.1 Ongoing operations demonstration of ALARP

Demonstrating ALARP has been undertaken in accordance with VOGA's Risk Management Manual and NOPSEMA Guidance Note N-04300-GN0166, ALARP [with the key principles of this Guidance Note (Health and Safety) also applies to Environmental Management]. Demonstrating that risks levels are ALARP is a two-step process. Firstly, residual risk levels must be tolerable, that is not within the "High" risk area of the VOGA Risk Matrix, once deemed tolerable further risk reduction measures must be identified and assessed for implementation as described below.

Following the identification of risk mitigation controls and recovery measures, VOGA reviews the residual risk and assesses whether there are any further measures required to reduce the residual risk to ALARP. Risks are considered to have been reduced to ALARP if the risks are within the tolerable region of the VOGA Risk Matrix and have been subject to a detailed assessment process that has concluded that there are no further reasonably practicable measures that can be implemented to further reduce the level of risk.

When deciding whether risks are managed to ALARP, the following items are considered:

- Duration and regularity of operations;
- Risk;
- Layers of protection;
- Feasibility of additional controls or alternative arrangements;
- Practicality of additional controls or alternative arrangements;
- Cost of additional controls or alternative arrangements;
- Effectiveness of additional controls or alternative arrangements;
- Impact on risks from additional controls or alternative arrangements; and
- Lessons learnt from past campaigns and industry.

This decision is valid where:

- All environmental hazards have been identified and assessed;
- Risk levels have been evaluated; and
- Residual risk levels are tolerable, compliant and ALARP.

Performance standards have been defined to ensure that the risks are reduced to ALARP on an ongoing basis. The VOGA risk matrix defines an upper threshold above which no risk is tolerable. Below this threshold is the ALARP region, where risks should be further reduced until the cost of

any additional action outweighs the incremental benefit gained. Numerical values for acceptance criteria are used to define the extremes of risks.

5.7.2 Concept evaluation ALARP demonstration

For evaluation of concepts a specific ALARP Demonstration Worksheets is completed in accordance with the processes defined in VOGA’s Risk Management Manual. For concept evaluations demonstration of ALARP contains elements of the following process:

- Identification and consideration of a range of potential measures for further risk reduction;
- Systematic analysis of each of the identified risk reduction measures and a view formed on the HSE benefit associated with each of them;
- Evaluation of the reasonable practicability of the identified measures;
- The implementation (or planned implementation) of the identified RRM’s; and
- Recording of the process and results.

The United Kingdom Offshore Operators Association (UKOOA) has produced guidelines for assisting with the ALARP decision-making process and for recording and demonstrating the robustness of the decision as depicted in Figure 5-3. These are regarded as good practice internationally and have been adopted globally as the standard guidance for ALARP decision making.

The UKOOA guidelines describe a framework that is intended to help decision-makers identify the various decision factors and establish a basis for the decision based on these. The decision framework assesses the significance to the decision process of codes and standards, good practice, engineering judgement, risk analysis, cost benefit analysis, and company and societal values. They aim to encourage the development of transparent decision-making processes.

Figure 5-3: UKOOA decision support framework

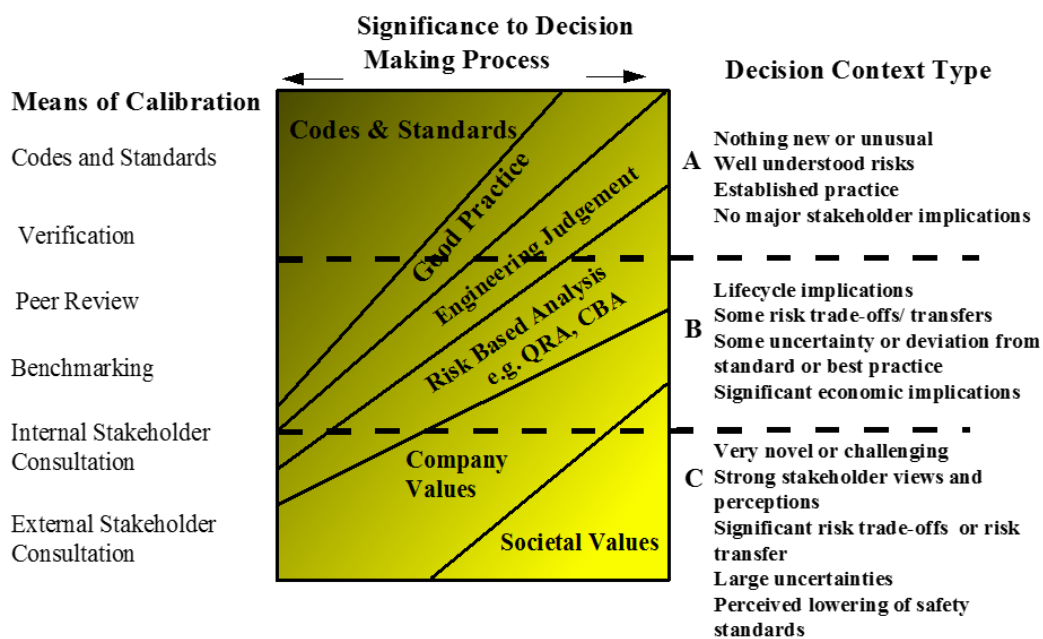

The first step in the decision-making process is to establish the decision context. This is done by assigning a decision context type (A-C), based on the categories and prompts detailed in Table 5-4.

Table 5-4: ALARP decision context type

Decision context	Description
A	Nothing new or unusual Well understood risks Established practice No major stakeholder implications
B	Lifecycle implications Some risk trade-offs/transfers Some uncertainty or deviation from standard or best practice Significant economic implications
C	Very novel or challenging Strong stakeholder views and perceptions Significant risk trade-offs or risk transfer Large uncertainties Perceived lowering of safety standards

The ALARP template provides questions around the decision context and prompts discussion to determine the appropriate context type.

Once the decision context has been established, Table 5-5 is then consulted to determine an appropriate method of decision making. For example, a design which involves nothing new or unusual, has well understood risks and no major uncertainties or shareholder implications, would be assigned a decision context in the middle of Type A as shown by the band on Figure 5-4.

Figure 5-4: Example decision making process

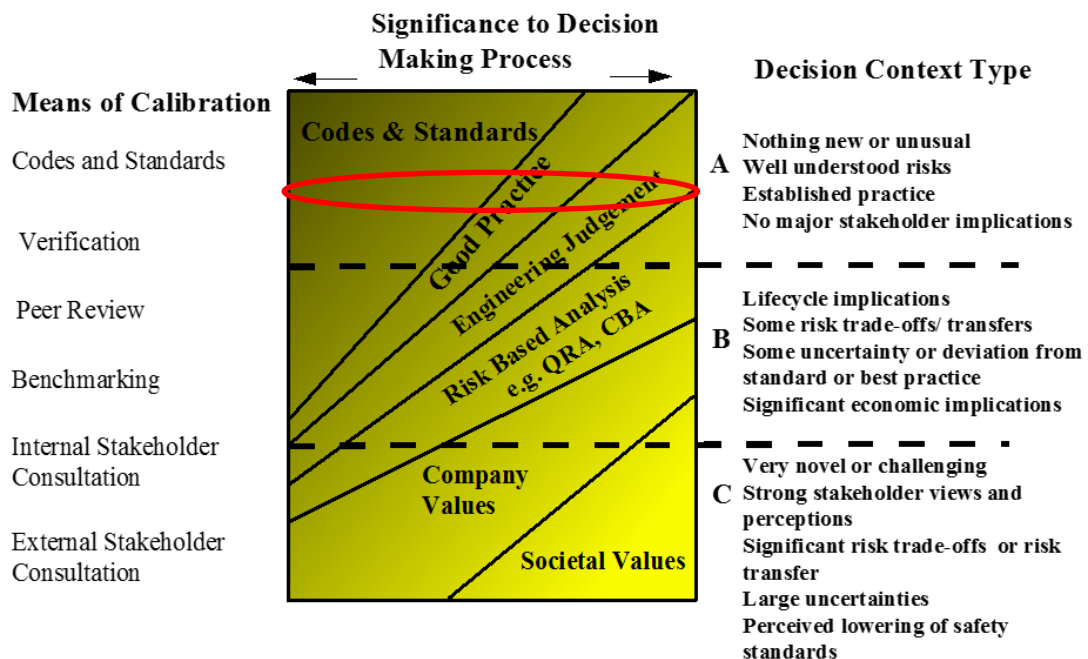

Reading across this band indicates the relative importance of each of the decision-making criteria; that is, the decision should be primarily based on the requirements of codes and standards, then engineering judgement and finally good practice. Quantitative Risk Assessment (QRA) should not be allowed to have a great influence on the decision. Consulting the codes and standards provides an appropriate means to calibrate the decision.

However, if the costs associated with the problem were considerable, or there were significant risk uncertainties, this would push the context towards Type B. In this case, some use of QRA and consideration of the company values would be appropriate.

Table 5-5 provides further explanation of each of the decision-making criteria.

Table 5-5: Decision criteria definitions

Decision criteria	Definition
Codes & Standards	Decision basis is to follow the requirements of relevant codes and standards. Codes and standards embody the lessons learnt over past years, and for well understood hazards and situations often provide an appropriate solution.
Good Practice	Decision basis is to follow what is generally accepted as current standard or good/best practice. Good practice embodies both the requirements of codes, etc. and other good engineering, analysis and management practices for common situations. Good practice may include solutions that have not yet found their way into codes and standards. What is good practice may differ from situation to situation. Care should be taken to benchmark against the relevant good practice or emerging practice.
Engineering Judgement	Decision basis is to follow what sound engineering judgement indicates is the best solution. This would be expected to include a recognition of what is good/best emerging practice, and an understanding and application of sound engineering and scientific principles and methods. It could include: engineering analysis, consequence modelling, deterministic cases for hazard management as well as competent judgment and interpretation of these and other information.
Risk Based Analysis (QRA, cost benefit analysis (CBA), etc.)	Decision basis is to make use of the results of probabilistic analyses such as QRA, reliability analysis and CBA to support the decision-making process. The assessment could be qualitative or quantitative. Uncertainties and the resolution of the analyses vs the needs of the decision will be key issues to address.
Company Values	Decision basis should take account of the views, concerns and perception of the stakeholders directly affected by the decision/option and the values of the company in terms of its safety commitment, image, etc.
Societal Values	Decision basis should take account of the views, concerns and perceptions of all the relevant stakeholders, including society at large.

The ALARP Demonstration Worksheet provides documentary evidence that the above process has been followed and requires a recommendation of the proposed solution that best meets the appropriate criteria.

5.8 Evaluating acceptability

Regulation 13(5)(c) of the OPGGS(E)R requires demonstration that environmental impacts and risks are of an acceptable level. VOGA only considers the level of residual impact or risk to be of an acceptable level when (in combination):

- Principles of ESD are not compromised;

- External Context – objects or claims made by external stakeholders considered;
- Internal Context – VOGA HSE policy / procedures are being met;
- Other Requirements eg Industry notices and guidance;
- Residual risk < High (RRII);
- EPO(s) manage impacts to acceptable level(s).

To demonstrate that potential environmental impacts and risk associated with Wandoo facility activities are of an acceptable level, the following process has been adopted to establish an acceptable level of residual risk for each aspect of the activity (either qualitative or quantitative) considering:

- The Principles of Ecological Sustainable Development (ESD) - the activity must be carried out in a manner consistent with the relevant ESD principles, namely:
 - decision making processes should effectively integrate both long term and short term economic, environmental, social and equitable considerations. This principal is inherently applied via the risk assessment methodology, inclusive of the demonstration of ALARP, detailed within this EP, as such this principal is not evaluated separately within each hazard assessment.
 - if there are threats of serious or irreversible environmental damage, lack of full scientific certainty should not be used as a reason for postponing measures to prevent environmental degradation. This principal is applied via the ALARP process in which a precautionary approach may be adopted where residual risks may be high-level or where there is a high degree of uncertainty in the outcomes of the activity.
 - the principle of inter-generational equity — that the present generation should ensure that the health, diversity and productivity of the environment is maintained or enhanced for the benefit of future generations. This principal is inherently applied via the risk assessment methodology, inclusive of the demonstration of ALARP, detailed within this EP, as such this principal is not evaluated separately within each hazard assessment.
 - the conservation of biological diversity and ecological integrity should be a fundamental consideration in decision making. This principal is applied by evaluating residual risks of operations activities to particular values and sensitivities, including matters protected under Part 3 of the EPBC Act 1999 considering relevant recovery plans and species conservation advices as detailed within Section 1.6
- Internal Context – the activity must be undertaken in a manner consistent with the objectives of the VOGA environmental policy and relevant procedural controls.
- External Context – where a relevant organisations' or persons' activity, function or interest may be affected by the activity, any objections or claims that have been assessed as having merit and are relevant to the activity should be considered when establishing the acceptable level of residual risk of the activity. The predicted level of residual risk presented within this EP shall be taken as acceptable in the context of external stakeholder expectations when:
 - the level of residual risk is equal to or below existing Stakeholder expectations in regard to their function, activity or interest; or
 - where no objection or claim is received from a relevant organisation or person.
- Other requirements - the residual risks associated with the activity are considered acceptable in the context of external requirements when they are within the bounds

identified in relevant laws, policies, standards, conventions and do not compromise the objectives of relevant recovery plans and species conservation advices as detailed within Section 1.6.

5.9 Performance outcomes, standards and measurement criteria

Environmental performance outcomes (EPOs), performance standards, and their measurement criteria, are defined for each control to ensure overall environmental performance is maintained at ALARP and acceptable levels.

The EPOs detailed within this EP are consistent with the Principles of ESD, provide for Matters Protected under Part 3 of the EPBC Act 1999, are relevant to the potential impacts and risks associated with the activity and maintain potential impacts and risks to acceptable levels based upon the context described in Section 5.8.

The EPOs detailed within this EP can be measured in various ways depending on if the acceptable level of impact or risk is quantitative or qualitative.

Quantitative levels of performance embedded within EPOs can be directly monitored and measured either prior to or after an impact has occurred (either planned or unplanned), while qualitative levels of performance can be assessed by validating the EPO remains achievable, relevant, or that the EPO has been maintained (or breached).

Hazard report tables contain the performance outcome statement and associated standards and measurement criteria for each of the material controls identified.

Within the detailed hazard assessment (Section 6), in order to ensure that control measures have a clear purpose, aspect/hazard-specific EPOs were determined for each receptor or receptor group. Each EPO is a qualitative or quantitative statement which typically links the control measure to an environmental outcome within acceptable levels of potential impact or risk. Where multiple controls protect against the same hazard, they may share a common performance outcome.

Once the performance outcome has been confirmed, a more specific statement on the level of performance required of the control is established – this is the performance standard. The performance standard may be a quantitative or qualitative statement of the functional requirement of a specific control. Note that for administrative controls such as procedures, performance standards are typically less specific than those for physical equipment.

Additionally, to ensure ongoing protection of Matters Protected under Part 3 of the EPBC Act, VOGA have developed a series of overarching EPOs that apply to all potential impacts and risks (both direct and indirect) that may result from the activity (Section 3.4). These EPOs are consistent with the Significant impact guidelines 1.2 – Actions on, or impacting upon, Commonwealth land and Actions by Commonwealth Agencies (Commonwealth of Australia, 2013) and consider relevant objectives from species Recovery Plans, conservation advices and Management Plans detailed in Section 1.6.

These EPOs represent a definitive level of impact and risk that is considered by VOGA to be unacceptable to Matters Protected under Part 3 of the EPBC Act 1999. A breach of an EPO would constitute a Major (4) environmental consequence.

Once environmental performance outcomes and performance standards are developed, it is important that the performance of the control can be tracked or monitored in some way to confirm it continues to meet the performance standards. To achieve this, a measurement criterion or means of assurance is specified. The measurement criterion varies, depending on the nature of the control.

In some cases, the performance standards identified are identical to existing Safety Critical performance standards for the control. In these cases, the full performance standard is not recorded in the table – rather a reference code in the form ‘WAN-WNB-CE-DC-03-01’ is included.

This code refers to the existing Safety Critical performance standard identification.

As noted in the VOGA Performance Standard Report [VOG-7000-RH-0009] some systems encompass both critical and non-critical elements; for example, some shutdown valves are designated as safety critical and some are not. Where a non-critical element shares the same function as an identified critical element, such as for non-critical shutdown valves, these elements are required to achieve the same performance criteria as the critical element and undergo the same assurance checks; however, the deviation management process is handled differently.

Where a non-critical control is identified, and it has no corresponding critical element to refer to, this EP details what its required performance/assurance criteria are

The VOGA performance standards identified for critical controls are provided in Appendix 5 of this EP.

5.10 Hazard report template

The risk assessment section of this EP is structured such that each of the hazards has a dedicated sub-section. Each sub-section commences with a “Hazard Report Table”, which is a tabular summary of the hazard, its causes, controls and impacts.

Each Hazard Report Table has multiple fields, which are described here. Each Hazard Report Table has three ‘heading rows’ containing:

- **Hazard:** This is a description of the hazard;
- **EP risk number:** This is a unique identification number applied to each risk;
- **CEE:** This is a unique identifier for those identified Catastrophic Environmental Events; and
- **Potential impacts:** This provides a high-level summary of the impacts to the environment which the hazard may cause.

The remainder of the table is divided into six columns, which contain the following fields:

- **Activity/cause:** This field outlines the typical activity/cause of environmental hazards as defined in Section 5.1;
- **Existing management controls:** This contains a description of the controls currently in place to prevent the hazard from occurring or to mitigate the impacts as defined in Section 5.1;
- **Control hierarchy:** This provides further information about the control, with respect to where it sits in a hierarchy of controls as defined in Section 5.1. This is included to allow the reader

to clearly determine the diversity of the controls in place for each particular scenario. The hierarchy of controls used in this assessment consisted of the following categories:

- Elimination;
- Substitution;
- Prevention;
- Reduction; and
- Mitigation.

Controls are further categorised as either an engineering control (i.e. a physical element/system) or administrative control (i.e. procedures).

The remaining columns contain the performance outcomes, performance standards, and their measurement criteria, as defined in Section 5.1.

6. Hazard assessment

6.1 Overview

The routine operation of the Wandoo Facility and accidental events associated with the Facility pose a range of different environmental risks. The risks have been assessed using the methodology outlined in Section 5 and are summarised in Table 6-1. Descriptions of these hazards and how they may occur at Wandoo, along with the measures to prevent and mitigate potential environmental impacts, are included in this section. Those events with a potential impact of Catastrophic have also been identified as CEEs and given a CEE-XX numerical designator.

Each hazard discussion comprises the following main parts:

- **Hazard report:** A table providing the description of the hazard, activity/cause, potential impacts, existing management controls, initial and residual risk ranking of the worst credible event, additional controls/demonstration of ALARP, performance outcomes, performance standards and measurement criteria for each control measure. A summary of the hazard report format is provided in Section 5.7.2. The Hazard Report essentially provides an executive summary of the hazard.
- **Description of hazard:** Describes the activity/cause of the hazard. This establishes the context for each individual hazard and aids in the risk assessment by providing maximum expected consequence extents. This section also includes a discussion of the management controls in place.
- **Impact assessment:** Describes the potential impact to receptors in the environment. This provides the risk assessment for each identified hazard.
- **CEE identification:** Identifies those circumstances where a release would have catastrophic potential and therefore a CEE would result. These events are designated as a CEE and a CEE-XX numerical designator allocated.
- **Critical Controls identification:** Once an event has been identified as a CEE the controls associated with that event must be assessed to determine which controls are considered critical.
- **Oil spill response strategy:** Only applies to those hazards which require activation of the oil spill response. This is a risk treatment specific to oil spill response.
- **Risk ranking:** All hazards are risk ranked in accordance with the process described in 5.6. For those hazards with a range of potential impacts are credible each impact is risk assessed separately. The worst credible risk is provided in the Hazard Report as a summary.
- **Acceptability/ALARP demonstration:** Describes the factors VOGA has considered in determining that the risks are acceptable and ALARP. This section describes the potential additional risk treatment options and implementation strategies. This section also provides this risk ranking for the identified hazard. Where there are a range of possible impacts assessed, a risk ranking is provided for each separate impact.

A number of unplanned events may also occur during Wandoo operations activities which may result in the potential release of hydrocarbons to the marine environment. These spill scenarios have been grouped according to the type of hydrocarbon, i.e. diesel, crude oil and HFO, and the potential point of release (i.e. sea surface release versus subsea release).

Table 6-1 provides a matrix of the hazards listed in against the activities outlined in Section 2.



Table 6-1: Summary of environmental hazards and risks for operational activities

EP risk no.	Hazard	Activity																										Residual risk ranking			Risk Assess. Section ref.												
		2.4	2.5	2.5.8	2.5.11	2.6.1	2.6.2	2.6.3	2.6.4	2.6.5	2.6.6	2.6.7	2.6.8	2.6.9	2.6.10	2.7.1	2.7.2	2.7.3	2.7.4	2.7.5	2.7.6	2.7.7	2.7.8	2.8.1	2.8.2	2.8.3	2.8.5	2.8.6	2.8.7	2.8.8		2.8.9	2.8.10	2.8.11	2.8.12	2.8.13	2.8.14	2.9.2	Consequence	Likelihood	Residual risk		
EP-OP-R01	Liquid hydrocarbon release from wells		X		X	X	X		X						X																							5	A	RRIII	6.2		
EP-OP-R02	Liquid hydrocarbon release from export equipment, submarine hose, floating hose or export flow lines				X	X	X		X																													5	A	RRIII	6.3		
EP-OP-R03	Crude oil spill from CGS		X		X	X	X		X																													5	A	RRIII	6.4		
EP-OP-R04	Environmental impacts of oil spill response																																					3	B	RRIII	6.5		
EP-OP-R05	Diesel spill to sea					X	X																															3	B	RRIII	6.6		
EP-OP-R06	Discharge of PFW and ballast water from Facility		X														X																						1	E	RRIII	6.7	
EP-OP-R21	Introduction of invasive marine pests				X	X	X																															4	B	RRIII	6.8		
EP-OP-R14	Non-hazardous and hazardous waste		X						X		X						X		X		X						X	X											1	E	RRIII	6.9	
EP-OP-R15	Use and discharge of chemicals for maintenance and inspection activities		X													X	X				X																		1	E	RRIII	6.10	
EP-OP-R07	Noise		X		X	X	X	X														X	X	X	X														1	E	RRIII	6.11	
EP-OP-R08	Atmospheric emissions		X	X	X	X	X	X		X			X	X																										1	E	RRIII	6.12
EP-OP-R09	Artificial light		X	X	X	X	X																																	1	E	RRIII	6.13
EP-OP-R10	Discharge of cooling water from Facility		X							X																														1	E	RRIII	6.14
EP-OP-R11	Vessel and Facility deck drainage and vessel bilge water discharge				X	X	X										X	X																						1	E	RRIII	6.15



EP risk no.	Hazard	Activity																									Residual risk ranking			Risk Assess. Section ref.											
		2.4	2.5	2.5.8	2.5.11	2.6.1	2.6.2	2.6.3	2.6.4	2.6.5	2.6.6	2.6.7	2.6.8	2.6.9	2.6.10	2.7.1	2.7.2	2.7.3	2.7.4	2.7.5	2.7.6	2.7.7	2.7.8	2.8.1	2.8.2	2.8.3	2.8.5	2.8.6	2.8.7		2.8.8	2.8.9	2.8.10	2.8.11	2.8.12	2.8.13	2.8.14	2.9.2	Consequence	Likelihood	Residual risk
EP-OP-R12	Discharge of sewage, greywater and putrescible waste from Facility and vessels				X		X		X	X																												1	E	RRIII	6.16
EP-OP-R13	Discharge of desalination brine		X										X																									1	E	RRIII	6.17
EP-OP-R16	Disturbance to marine fauna and seabirds			X	X		X	X	X																	X												1	C	RRIV	6.18
EP-OP-R17	Liquid hydrocarbon release from topsides process					X																X															2	B	RRIV	6.19	
EP-OP-R18	Ancillary hydrocarbon or chemical spills									X																											1	B	RRIV	6.20	
EP-OP-R19	Physical presence of infrastructure	X			X																															X	1	B	RRIV	6.21	
EP-OP-R20	Seabed disturbance							X																		X	X		X	X	X					X	1	C	RRIV	6.22	
EP-OP-R22	Liquid hydrocarbon release from flow lines and risers		X		X	X	X		X																											X	1	B	RRIV	6.23	



6.2 Liquid hydrocarbon release from wells

6.2.1 Hazard report

Table 6-2: Hazard report – Liquid hydrocarbon release from wells

HAZARD:	Liquid hydrocarbon release from wells					
EP risk no.:	EP-OP-R01					
CEE:	CEE-01 – Production well blowout					
Potential impacts:	Liquid hydrocarbon release of up to 4,364m ³ surface release of Wandoo Crude over 68 days of oil to sea (commencing 10 days after incident).					
PREVENTION:						
Activity/cause	Existing management controls	Control type	Control hierarchy	Performance outcome	Performance standard	Measurement criteria
Well intervention operation. Rigless well intervention SL/ electric line/ coiled tubing/ hydraulic workover/ well pumping operations. Entering production well.	Primary well control systems.	Engineering	Prevention	Execute well intervention campaigns in a manner to prevent loss of hydrocarbons resulting in environmental impacts.	Performance criteria, as per WAN-WNAB-CP-PR-06-04– Primary Well Control. Well control shall be maintained at all times during well intervention operations	Assurance records, as per WAN-WNAB-CP-PR-06-04– Primary Well Control.
	Secondary well control equipment.	Engineering	Prevention		Performance criteria, as per WAN-WNAB-CP-PR-06-05– Secondary Well Control Equipment. Well Control and Pressure Control Equipment shall be appropriate for providing control of the well	Assurance records, as per WAN-WNAB-CP-PR-06-05– Secondary Well Control Equipment.
	Well barrier envelope.	Engineering	Prevention		Performance criteria, as per WAN-WNAB-CP-PR-06-06 – Well Barrier Elements. Casing and other well equipment shall be designed to contain any anticipated pressure during the lifecycle of the well..	Assurance records, as per WAN-WNAB-CP-PR-06-06 – Well Barrier Elements.
					Performance criteria, as per WAN-WNAB-CP-PR-06-07 – Cement. All cement slurries when designed to act as barriers shall, following implementation, result in the cured cement providing a barrier which meets the barrier specifications defined in the WCSM.	Assurance records, as per WAN-WNAB-CP-PR-06-07 – Cement.
					Performance criteria, as per WAN-WNAB-CP-PR-06-08 – Well Barriers. Well barriers are designed to contain anticipated pressure during the lifecycle of the well and shall be installed in accordance with the Well Construction Management System.	Assurance records, as per WAN-WNAB-CP-PR-06-08 – Well Barriers.
Loss of barrier envelope during production operations.	Well design.	Engineering	Prevention	Prevent the release of hydrocarbon from wells to the marine environment due to loss of well integrity.	Performance criteria, as per WAN-WNAB-CE-PR-02-01 – Wellhead/Trees, Valves, Instrumentation & Casings defined in the containment envelope (barrier). Wellhead and trees shall contain pressurised hydrocarbons.	Assurance records, as per WAN-WNAB-CE-PR-02-01 – Wellhead/Trees, Valves, Instrumentation & Casings defined in the containment envelope (barrier).



Activity/cause	Existing management controls	Control type	Control hierarchy	Performance outcome	Performance standard	Measurement criteria
					Performance criteria, as per WAN-WNAB-CE-PR-02-02 – Wellhead Actuated Valves (WAVs). WAVs shall close on demand and contain pressurised hydrocarbons.	Assurance records, as per WAN-WNAB-CE-PR-02-02 – WAVs.
					Performance criteria, as per WAN-WNAB-CE-PR-02-03 – SSSVs. SSSVs shall isolate well fluids.	Assurance records, as per WAN-WNAB-CE-PR-02-03 – SSSVs.
					Performance criteria, as per WAN-WNAB-CE-PR-02-04 – GLV. GLV shall isolate well fluids.	Assurance records, as per WAN-WNAB-CE-PR-02-04 – GLV.
					Performance criteria, as per WAN-WNAB-CE-PR-02-05 – Annulus. Production and Surface Annuli shall contain pressurised hydrocarbons should a primary barrier fail.	Assurance records, as per WAN-WNAB-CE-PR-02-05 – Annulus.
	Instrumentation initiators, alarms and final elements.	Engineering	Prevention		Performance criteria to ensure maintenance and inspection of instrumentation initiators, alarms and final elements relevant to wells, as per the following: <ul style="list-style-type: none"> • WAN-WNAB-CE-DC-02 - Instrument Protective and Alarm Systems • WAN-WNAB-CE-DC-07 - Integrated Control System • WAN-WNAB-CE-PR-02-02 – WAVs. 	Assurance records, as per <ul style="list-style-type: none"> • WAN-WNAB-CE-DC-02 - Instrument Protective and Alarm Systems • WAN-WNAB-CE-DC-07 - Integrated Control System • WAN-WNAB-CE-PR-02-02 – WAVs.
	Well integrity management and monitoring of barrier status.	Administrative	Reduction		Performance criteria, as per WAN-WNAB-CP-PR-04-02 – Inspection, maintenance, monitoring and testing. Integrity management systems provide for the inspection, maintenance, monitoring and testing of CEs to identify deterioration and ensure ongoing integrity.	Assurance records (audits and KPIs), as per WAN-WNAB-CP-PR-04-02 – Inspection, maintenance, monitoring and testing.
Well maintenance equipment failure.	Equipment maintenance, inspection and testing.	Administrative	Reduction		Performance criteria, as per WAN-WNAB-CP-PR-04-02 – Inspection, maintenance, monitoring and testing. Integrity management systems provide for the inspection, maintenance, monitoring and testing of CEs to identify deterioration and ensure ongoing integrity.	Assurance records (audits and KPIs), as per WAN-WNAB-CP-PR-04-02 – Inspection, maintenance, monitoring and testing.
Human error during work-over, intervention or	Permit to work system.	Administrative	Reduction		To ensure that permitted operations are controlled and conducted accordance with the Work Management Manual [WPA-7000-YG-0021].	Permit to work forms are completed in accordance with the Work Management Manual (WPA-7000-YG-0021).



Activity/cause	Existing management controls	Control type	Control hierarchy	Performance outcome	Performance standard	Measurement criteria
production operations.	Contractor/vendor selection and management.	Administrative	Reduction		Contractors/vendors shall undertake activities without compromising VOGA's HSE performance and objectives. A pre-qualification process exists that ensures contractors / vendors have the capability to meet VOGA HSE performance requirements and objectives	Records of Contractor HSE prequalification records as per requirements of VOGA Contractor/Vendor Selection And Management Manual (VOG-1000-MN-0001).
Structural failure of the platform due to fatigue/ageing asset.	Structures (Super- and Substructures)	Engineering	Prevention		Performance criteria, as per WAN-WNAB-CE-PR-07-01 – All structures shall be designed to provide support to critical control measures.	Assurance records, as per WAN-WNAB-CE-PR-07-01 – All structures.
	Asset integrity management.	Administrative	Prevention		Performance criteria, as per WAN-WNAB-CP-PR-04-04 – Integrity Management. The integrity of critical elements is maintained at all times.	Assurance records as per WAN-WNAB-CP-PR-04-04 – Integrity Management.
Dropped object/ swinging load onto wellhead during well intervention activities.	Lifting management procedures.	Administrative	Reduction		Crane operations shall be managed as per the Crane Operations, Maintenance and Inspection Manual [WPA-7000-YM-0002] to ensure safe lifting operations to prevent dropped objects or swinging loads.	Crane Operator Checklist completed prior to crane operation.
	Crane maintenance.	Engineering	Prevention		Performance criteria, as per WAN-WNAB-CE-PR-05-01 - Platform Cranes and Man-riding Winch shall be maintained to enable safe lifting operations to prevent dropped objects or swinging loads	Assurance records, as per WAN-WNAB-CE-PR-05-01 - Platform Cranes and Man-riding Winch.
Passing vessel collision with Platform.	Emergency communications.	Engineering	Prevention	Prevent a crude oil spill oil to the marine environment from wells due to vessel collision.	Performance criteria, as per WAN-WNAB-CE-ES-02-01 – UHF/VHF Radios. To ensure communication between CCR and the Emergency Response Team (at any location on the installations), personnel on WNA, personnel on CALM Buoy and external parties.	Assurance records, as per WAN-WNAB-CE-ES-02-01 – UHF/VHF Radios.
	Navigation aids.	Engineering	Reduction		Performance criteria, as per: <ul style="list-style-type: none"> WAN-WNAB-CE-PR-06.01 - Navigation Lights. To provide visual indication to marine vessels of the position of the installation (WNA & WNB) so that they may take timely action to avoid the area. WAN-WNAB-CE-PR-06.02 - Fog Horn. To provide audible indication to marine vessels of the position of each fixed installation (WNA and WNB) so that they may take timely action to avoid the area. 	Assurance records, as per: <ul style="list-style-type: none"> WAN-WNAB-CE-PR-06.01 - Navigation Lights. WAN-WNAB-CE-PR-06.02 - Fog Horn.
	Platform location published on Marine Charts.	Administrative	Reduction		Wandoo facilities are marked on marine charts and any changes to Wandoo facilities notified via Notices to Mariners.	Records to confirm that Wandoo facilities are on chart and applicable Notice to Mariners.
	500m restriction zone surrounding the facility.	Administrative	Reduction		500m restriction zone surrounding the facility, as per the Wandoo Marine Operations Manual [WNB-1000-YV-0001].	Wandoo Marine Operations Checklist.
Attending vessel collision with Platform.	Station keeping requirements for vessels.	Administrative	Reduction	Prevent the release of hydrocarbons to the marine	Dynamic positioning requirements, as per Section 9 of the Wandoo Marine Operations Manual [WNB-1000-YV-0001].	Wandoo Marine Operations Checklist.



Activity/cause	Existing management controls	Control type	Control hierarchy	Performance outcome	Performance standard	Measurement criteria
	Vessel operations restricted in adverse weather.	Administrative	Reduction	environment due to vessel collision with the platform.	Vessel operations restricted in adverse weather, as per the Wandoo Marine Operations Manual [WNB-1000-YV-0001].	Wandoo Marine Operations Checklist.
	Permission required for field entry, CALM Buoy approach, mooring-up and departure.	Administrative	Reduction		Vessels shall comply with permissioning protocols for vessels entering the field, CALM Buoy approach, mooring-up and departure, as per the Wandoo Marine Operations Manual [WNB-1000-YV-0001].	Wandoo Marine Operations Checklist.
Tanker station keeping failure.	Hawser is fit for purpose.	Engineering	Reduction	Prevent the release of hydrocarbons to the marine environment due to tanker collision with the platform.	Hawser, chains and shackles shall be checked for mechanical damage and wear prior to offtake, as per the SPM Marine Facility Procedures [WPA-7000-YV-0002].	Offtake Maintenance Report.
	Structural integrity of CALM Buoy mooring.	Administrative	Reduction		Performance criteria, ensuring inspection of CALM buoy mooring as per <ul style="list-style-type: none"> • WAN-WNB-CE-PR-07-03. 01 - Mooring System - CALM Buoy, including mooring arm • WAN-WNB-CE-PR-07-03. 02 - Mooring System - Chains and Anchors 	Assurance records, as per <ul style="list-style-type: none"> • WAN-WNB-CE-PR-07-03. 01 - Mooring System - CALM Buoy, including mooring arm • WAN-WNB-CE-PR-07-03. 02 - Mooring System - Chains and Anchors
	Weather restrictions apply to offtake activities.	Administrative	Reduction		Offtake operations shall be restricted in adverse weather, as per the SPM Marine Facility Procedures [WPA-7000-YV-0002].	Offtake Maintenance Report.
	Wandoo Mooring Master on board tanker during offtake.	Administrative	Reduction		Wandoo Mooring Master meets minimum competency standard as per contract	Training records confirmed for Mooring Master
	Static tow by support vessel to control tanker position	Engineering	Reduction		A support vessel shall be present to assist with each offtake operation and must remain connected to the Tanker, providing static tow, throughout the offtake as per as per the SPM Marine Facility Procedures [WPA-7000-YV-0002].	Safety Checklist

MITIGATION:						
Existing management controls	Control type	Control hierarchy	Performance outcome	Performance standard	Measurement criteria	
Shutdown system.	Engineering	Mitigation	Mitigate the impact of a hydrocarbon release from Wandoo wells to the marine environment by: <ul style="list-style-type: none"> • Isolating the well inventory; • Containing small releases; and • Responding to oil releases to the environment. 	Refer to instrumentation initiators, alarms and final elements in the Prevention section of the hazard table above	Assurance records	
	Engineering	Mitigation		SIMOPS plan shall cover ESD and Wandoo Emergency Response Plan (ERP) actions between well intervention team and Wandoo operations.	SIMOPS plan is issued and available and Well intervention induction covers ERP and ESD response actions.	
Wandoo Emergency Response Plan [VOG-2000-RD-0017]/ Source Control Contingency Plan [WNB-3000-PD-0007].	Administrative	Mitigation		The Wandoo Emergency Response Plan [VOG-2000-RD-0017] and Source Control Contingency Plan [WNB-3000-PD-0007] shall meet the performance criteria as per WAN-WNAB-CP-ER-01 – Emergency preparedness, managements and response	Assurance criteria as per WAN-WNAB-CP-ER-01 - Emergency preparedness, managements and response.	



Existing management controls		Control type	Control hierarchy	Performance outcome	Performance standard	Measurement criteria
					Source Control Contingency Plan [WNB-3000-PD-0007] reviewed prior to heavy well intervention operations for any well capable of sustaining flow to surface. This includes an assessment of flow rate and duration of new wells using reservoir simulation modelling. If the assessment indicates the potential for worst case discharge parameters to be exceeded, the management of change process will be undertaken in accordance with Section 7.8.	Review records Management of change records
					Relief Well Rig Availability Register: Suitable rigs for relief well operations are identified at the time of reviewing the Source Control Plan, and VOGA tracks MODU activity within the region and updates the register on a monthly basis during heavy well intervention operations for any well capable of sustaining flow to surface.	Relief well rig availability register records
Key component as outlined in WAN-WNAB-CP-ER-02-01 OSR Arrangements.	The Wandoo Field OSCP is established to mitigate the oil spill hazards identified in the respective environment plan.	Administrative	Mitigation	To mitigate the environmental impacts as a result of oil spill, by ensuring that measures are in place to mitigate the oil spill hazards associated with activities within the Wandoo Field.	Performance criteria, as per WAN-WNAB-CP-ER-02-01 - OSR Arrangements	Assurance activities, as per WAN-WNAB-CP-ER-02-01 - OSR Arrangements.
	Response strategies provided in the OPPs are appropriate to: <ul style="list-style-type: none"> the nature and scale and associated environmental impact of the potential spill hazards; the nature and scale and associated environmental impact of the potential spill response strategies; and the environmental sensitivities and priorities as outlined within the respective environment plan. 	Administrative	Mitigation		Performance criteria, as per WAN-WNAB-CP-ER-02-01 - OSR Arrangements	Assurance activities, as per WAN-WNAB-CP-ER-02-01 - OSR Arrangements.
	The Wandoo Field OSCP describes incident management system and interfaces.	Administrative	Mitigation		Performance criteria, as per WAN-WNAB-CP-ER-02-01 - OSR Arrangements	Assurance activities, as per WAN-WNAB-CP-ER-02-01 - OSR Arrangements.
	Decision making processes support mitigation of environmental impact of spills and assessment of effectiveness of response strategies.	Administrative	Mitigation		Performance criteria, as per WAN-WNAB-CP-ER-02-01 - OSR Arrangements	Assurance activities, as per WAN-WNAB-CP-ER-02-01 - OSR Arrangements.



Existing management controls		Control type	Control hierarchy	Performance outcome	Performance standard	Measurement criteria
	The Wandoo Field OSCP shall contain processes to assess, test and maintain arrangements to meet the Wandoo Field OSCP outcomes through: <ul style="list-style-type: none"> assurance processes; capability assessment; and review triggers. 	Administrative	Mitigation		Performance criteria, as per WAN-WNAB-CP-ER-02-01 - OSR Arrangements	Assurance activities, as per WAN-WNAB-CP-ER-02-01 - OSR Arrangements.
Key component as outlined in WAN-WNAB-CP-ER-02-02 Resources defined and available in a timely manner.	Equipment, services and personnel required for the first 20 days are identified within the OPPs.	Administrative	Mitigation		Performance criteria, as per WAN-WNAB-CP-ER-02-02 - Resources defined and available in a timely manner	Assurance activities, as per WAN-WNAB-CP-ER-02-02 - Resources defined and available in a timely manner.
	A logistics management plan is in place to inform deployment of resources in a timely manner.	Administrative	Mitigation		Performance criteria, as per WAN-WNAB-CP-ER-02-02 - Resources defined and available in a timely manner	Assurance activities, as per WAN-WNAB-CP-ER-02-02 - Resources defined and available in a timely manner.
	Contracts are established for equipment and services for the full duration of a response.	Administrative	Mitigation		Performance criteria, as per WAN-WNAB-CP-ER-02-02 - Resources defined and available in a timely manner	Assurance activities, as per WAN-WNAB-CP-ER-02-02 - Resources defined and available in a timely manner.
Key component as outlined in WAN-WNAB-CP-ER-03-01 Response strategy - Monitor and evaluate.	Ensure the most effective response strategies are being applied and environmental impact of the spill and response strategies are measured.	Administrative	Mitigation	To mitigate the environmental impacts as a result of oil spill, by ensuring that the most effective response strategies are being applied and environmental impact of the spill and response strategies are measured.	Performance criteria, as per WAN-WNAB-CP-ER-03-01 - Response strategy - Monitor and evaluate	Assurance activities, as per WAN-WNAB-CP-ER-03-01 - Response strategy - Monitor and evaluate.
Key component as outlined in WAN-WNAB-CP-ER-03-02 Response Strategy - Chemical dispersant application.	Increase the rate of biodegradation to reduce the environmental impact from surface oil and oil stranding on shoreline sensitivities.	Administrative	Mitigation	To mitigate the environmental impacts as a result of oil spill, by increasing the rate of biodegradation to reduce the environmental impact from surface oil and oil stranding on shoreline sensitivities.	Performance criteria, as per WAN-WNAB-CP-ER-03-02 - Response Strategy - Chemical dispersant application	Assurance activities, as per WAN-WNAB-CP-ER-03-02 - Response Strategy - Chemical dispersant application.
Key component as outlined in WAN-WNAB-CP-ER-03-03 Response strategy - Mechanical dispersant application.	Assist natural dispersion of oil into the water column to reduce environmental impact from surface oil.	Administrative	Mitigation	To mitigate the environmental impacts as a result of oil spill, by assisting natural dispersion of oil into the water column to reduce environmental impact from surface oil.	Performance criteria, as per WAN-WNAB-CP-ER-03-03 - Response strategy - Mechanical dispersant application	Assurance activities, as per WAN-WNAB-CP-ER-03-03 - Response strategy - Mechanical dispersant application.
Key component as outlined in WAN-WNAB-CP-ER-03-04 Response strategy - Containment and recovery.	Reduce overall volume of surface oil to minimise impacts to environmental sensitivities.	Administrative	Mitigation	To mitigate the environmental impacts as a result of oil spill, by reducing the overall volume of surface oil to minimise impacts to environmental sensitivities.	Performance criteria, as per WAN-WNAB-CP-ER-03-04 - Response strategy - Containment and recovery	Assurance activities, as per WAN-WNAB-CP-ER-03-04 - Response strategy - Containment and recovery.
Key component as outlined in WAN-WNAB-CP-ER-03-05 Response strategy - Protection and deflection.	Minimise environmental impacts to priority near-shore environmental sensitivities by reducing oil contact.	Administrative	Mitigation	To mitigate the environmental impacts as a result of oil spill, by reducing oil contact to priority near-shore environmental sensitivities.	Performance criteria, as per WAN-WNAB-CP-ER-03-05 - Response strategy - Protection and deflection	Assurance activities, as per WAN-WNAB-CP-ER-03-05 - Response strategy - Protection and deflection.
Key component as outlined in WAN-WNAB-CP-ER-03-06 Response strategy - Shoreline clean-up.	Remove stranded hydrocarbons from shorelines without causing greater environmental impact than leaving the hydrocarbons in-situ.	Administrative	Mitigation	To mitigate the environmental impacts as a result of oil spill, by removing stranded hydrocarbons from shorelines without causing greater environmental impact than leaving the hydrocarbons in-situ.	Performance criteria, as per WAN-WNAB-CP-ER-03-06 - Response strategy - Shoreline clean-up	Assurance activities, as per WAN-WNAB-CP-ER-03-06 - Response strategy - Shoreline clean-up.



Existing management controls		Control type	Control hierarchy	Performance outcome	Performance standard	Measurement criteria
Key component as outlined in WAN-WNAB-CP-ER-03-07 Response strategy - Oiled wildlife response.	Minimise and mitigate the number of wildlife oiled following a spill.	Administrative	Mitigation	To mitigate the environmental impacts as a result of oil spill, by minimising and mitigating the number of wildlife oiled following a spill.	Performance criteria, as per WAN-WNAB-CP-ER-03-07 - Response strategy - Oiled wildlife response	Assurance activities, as per WAN-WNAB-CP-ER-03-07 - Response strategy - Oiled wildlife response.
Key component as outlined in WAN-WNAB-CP-ER-01-04 Arrangements are accessible.	Current oil spill response arrangements are accessible to all personnel in the event of an oil spill.	Administrative	Mitigation	To mitigate the environmental impacts as a result of oil spill, by ensuring that measures are in place to mitigate the oil spill hazards associated with activities within the Wandoo Field.	Performance criteria, as per WAN-WNAB-CP-ER-01-04 - Arrangements are accessible	Assurance activities, as per WAN-WNAB-CP-ER-01-04 - Arrangements are accessible.
Key component as outlined in WAN-WNAB-CP-ER-01-05 Arrangements are understood.	Oil spill response personnel understand and competently perform their response roles.	Administrative	Mitigation	To mitigate the environmental impacts as a result of oil spill, by ensuring that measures are in place to mitigate the oil spill hazards associated with activities within the Wandoo Field.	Performance criteria, as per WAN-WNAB-CP-ER-01-05 - Arrangements are understood	Assurance activities, as per WAN-WNAB-CP-ER-01-05 - Arrangements are understood.
INITIAL RISK WITH EXISTING CONTROLS:						
Consequence		Likelihood (of consequence)			Initial risk	
Catastrophic (5)		Rare (A)			Medium	
ADDITIONAL CONTROLS/DEMONSTRATION OF ALARP - VOGA WORKSHOP:						
Medium risk is defined as tolerable on demonstration of ALARP under the VOGA risk level action criteria. The following ALARP analysis provides assurance that all risk treatment options have been considered.						
Additional management controls		Assessment of option				Adopted/not adopted
Refer to Section 6.2.7 for source control and oil spill response ALARP evaluation tables.						
Standby vessel in situ 24 hrs/day:		Monitor the PSZ and be equipped with an automatic identification system to aid in its detection at sea, and radar to aid in the detection of approaching third-party vessels. Reduces risk of vessel collision and subsequent unplanned release of hydrocarbons High cost associated with contracting standby vessel. Costs of operating navigational equipment. The costs associated with having a vessel on location 24/7 are considered disproportionate to the environmental benefit gained, particularly given the infrastructure are marked on charts and navigational aids are present.				Not adopted
RESIDUAL RISK AFTER ADDITIONAL CONTROLS:						
Consequence		Likelihood (of consequence)			Residual risk	
Catastrophic (5)		Rare (A)			Medium	
ACCEPTABLE LEVEL OF RISK DEMONSTRATED:						
External Context – objects or claims considered	Internal Context – VOGA HSE / procedures met		Other Requirements met	RR < High (RRII)	EPO(s) manage risk to acceptable level(s)	
N/A – no external objections or claims received	Yes – Risk managed in accordance with VOGA HSE policy and aligned to Performance Standards, Wandoo Marine Operations Manual [WNB-1000-YV-0001] and SPM Marine Facility Procedures [WPA-7000-YV-0002]. Potential spills to be managed in accordance with Wandoo Emergency Response Plan [VOG-2000-RD-0017]/Wandoo Field OSCP [WAN-2000-RD-0001].		Yes – relevant API standards form basis of several performance standards	Yes –RRIII (Medium)	Yes, EPOs specify no uncontrolled release of hydrocarbons. The following relevant overarching EPOs (Section 3.4) maintained providing control measures maintained: EPO-OP-01; EPO-OP-03; EPO-OP-04; EPO-OP-05; EPO-OP-06; EPO-OP-07; EPO-OP-08; EPO-OP-09; EPO-OP-10; EPO-OP-11; EPO-OP-12; EPO-OP-13; EPO-OP-16; EPO-OP-17; EPO-OP-18; EPO-OP-19; EPO-OP-20	

6.2.2 Description of hazard

6.2.2.1 Overview

Based on the Safety Case and environmental hazard review workshops held, a well barrier failure resulting in a loss of hydrocarbon could occur from the following activity/causes:

- Well intervention operations;
- Loss of well integrity;
- Structural failure of platform due to fatigue/ageing asset;
- Vessel collision with platform; and
- Dropped object or swinging load onto the wellhead.

Vermilion has assessed current and potential production wells to help inform a worst-case spill rate and duration, see Section 3.2.

Reservoir modelling (Ref WNB-7500-RG-0002) indicates that a maximum worst case release from a production well could result in up to 4,364 m³ (or 31,692 bbl) surface release of Wandoo crude for 68 days, commencing 10 days after the event. VOGA has assumed that 78 days (see Section 6.2.3) would be required to drill a relief well and control a well release based on the Source Control Contingency Plan.

To ensure that the flow rate and duration of a blowout for any new wells proposed in Wandoo Field remain within the worst-case discharge parameters, new wells will be assessed using reservoir simulation modelling. If the assessment indicates the potential for worst case discharge parameters to be exceeded, the management of change process will be undertaken in accordance with Section 7.8 which includes a review of regulatory compliance.

6.2.2.2 Well intervention operations

VOGA prepares a detailed program for each well activity to communicate the intended work scope and the well barriers to be in place during the campaign. As part of VOGA's risk management process, the primary failure modes associated with other industry loss of control events are considered during the engineering, designing, planning and preparation for well construction and intervention operations.

MoC procedures are applied to ensure that a rigorous process is applied to assess and manage any risk associated with changes to designs or plans.

For well integrity critical equipment, VOGA only procure or rent equipment that meets relevant API or ISO standards. The relevant standards for the various equipment types used during VOGA's well construction and intervention activities are specified in the VOGA Well Construction Standards Manual. Pressure control equipment that meets VOGA's well construction standards is installed and tested on a well in accordance with the operations program.

The operations program defines the barriers that are to be in place at each phase of the planned activity, and the verification process required to demonstrate effectiveness. VOGA has a rigorous

barrier verification process, including interfaces between well construction and production during the well handover phase. The Intervention Contractor's lead hand and VOGA's Intervention Supervisor have to sign off at any point where barrier systems change, to confirm that the VOGA barrier standards have been effectively applied.

Pressure control equipment is pressure tested prior to mobilisation.

VOGA requires that their contractors demonstrate that they operate under a competency management system that ensures their personnel are competent for their assigned positions.

VOGA's senior intervention personnel will hold current well control certification from the International Well Control Forum or International Association of Drilling Contractors, providing an internationally recognised level of well control competence assurance. Training and induction processes will ensure that the contractors intervention team have complete autonomy and understand that VOGA's expectation is that the well will be shut-in at any time when concerns are raised with respect to well control.

Critical intervention equipment is maintained in accordance with the Intervention Contractor's preventative maintenance system.

While well construction operations are ongoing, the reservoir will continue to exhibit a sub-hydrostatic pressure regime requiring a very high level of underbalance to achieve flow to surface.

6.2.2.3 *Loss of well integrity*

Monitoring of annulus pressures and leak testing of wellhead valves and seals is carried out during production operations a per VOGA performance standards. Seal failure would not result in a continuous loss of well fluids; rather it would be similar in nature to riser leak events provided in Section 6.23. Should the seals fail, then the SSSV would impede the hydrocarbon flowing into the marine environment.

Risk to well integrity encountered during production operations is addressed by effective well design with critical erosion and corrosion tolerances. The SSSV is designed against erosion, and erosion would not result in complete well failure. As they are installed in the fluid flow path, there is an expectation that they will leak on closure. ISO standards allow for a limited leak rate from SSSVs on testing.

Risk to well integrity encountered during production operations is addressed by design specification of the well and corrosion monitoring, and the use of corrosion inhibition treatment during operations.

6.2.2.4 *Structural failure of platform due to fatigue/aging asset*

The Asset Integrity Management System provides a process to maintain and monitor the performance of the WNA and WNB structures to relevant codes and standards as per the facilities' Basis of Design.

Independent design validation/verification for life extension to manage asset beyond design life.

6.2.2.5 *Vessel collision with platform*

Collision avoidance controls vary depending on whether the potential colliding vessel is a passing vessel, attending vessel or an offtake tanker. Controls for passing and attending vessels include communication and navigation systems, and management systems (e.g. 500m restriction zone, weather restrictions).

Controls to prevent loss of offtake tanker station keeping include the following:

- A hawser fit for purpose;
- Structural integrity of CALM Buoy mooring;
- Static tow operations; and
- Management controls over the offtake operation including weather restrictions and use of a Mooring master on the tanker.

The feasibility of installing and using AIS (Automatic identification system) on the Wandoo facilities is currently being assessed.

6.2.2.6 *Dropped objects/swinging loads onto wellhead*

Crane operations are managed on the Wandoo Facilities through the administrative procedures within the Crane Operations, Maintenance and Inspection Manual [WPA-7000-YM-0002] and Lifting Management Manual [WPA-7000-YM-0002]. Certified lifting equipment is considered essential in preventing dropped objects and therefore a Critical Control in protecting against potential environmental hazards. All lifting equipment on WNA and WNB are managed as a Critical Element, with lifting over live wells managed as a critical lift.

6.2.3 **Impact assessment**

6.2.3.1 *Key findings from OSTM Report (Appendix 3)*

Area of surface oil

The use of surface dispersant demonstrated a noticeable reduction of the sea surface exposure at, or above the low and moderate thresholds, hence resulting in a lesser number of environmental receptors potentially exposed to surface hydrocarbons.

The maximum distance from the release location to the low (1-10 g/m²), moderate (10-50 g/m²) and high (>50 g/m²) exposure thresholds was 922 km west-northwest (transitional), 186 km west-northwest (summer), respectively for the unmitigated case. For the mitigated case the maximum distance was 341 km and 6km, respectively, for the transitional and summer results. No high exposure was predicted for any of the spill trajectories in the unmitigated or mitigated cases.

For spills commencing during summer, transitional and winter conditions, the following receptors recorded oil exposure on the sea surface (at the low threshold) at probabilities greater than 80% across all seasons: Ancient coastline at 125 m depth contour Key Ecological Feature (KEF) and the Northwest Shelf Integrated Marine and Coastal Regionalisation of Australia (IMCRA).

Length of shoreline contact

For all seasonal conditions assessed, the modelling demonstrated a reduction in the length of shoreline contact (above 10 g/m²), when the surface dispersant was applied. For the unmitigated case, at, or above, the low threshold (10 g/m²) during the summer, transitional and winter seasons was 71 km, 28 km and 17 km, respectively, compared to 20 km, 7 km, 9 km for the mitigated case, or a reduction of 72%, 75% and 47%, respectively.

Volume of oil on shore

The greatest volume of oil on shore from a single spill trajectory was predicted to reduce from 303 m³, to 52 m³ when the mitigation option was considered. This represented a reduction of 82%.

Dissolved hydrocarbon exposure

There was an increase in the dissolved hydrocarbon exposure concentrations within the 0-10 m, 10-20 m and 20-30 m depth layers following the application of surface dispersant. However, the extents remain the same when compared to the unmitigated results. It is worth noting that none of the receptors assessed were predicted to be exposed at, or above the high thresholds. None of the receptors assessed were predicted to be exposed at, or above the high (≥ 400 ppb) threshold.

In the surface (0-10 m) depth layer, the Northwest Shelf IMCRA recorded the greatest probability of instantaneous dissolved hydrocarbon exposure at low threshold during all three seasons for the unmitigated (1-2%) and mitigated (1-2%) cases.

In the 10-20 m depth layer, the Northwest Shelf IMCRA also recorded probabilities low dissolved hydrocarbon exposure of up to 2% for the unmitigated case and 2%, for the mitigated option.

Entrained hydrocarbon exposure

There was an increase in the extent and concentrations for entrained hydrocarbons within the 0-10 m depth layer following the application of surface dispersant.

The modelling showed during summer conditions demonstrated a broader range of sensitive receptors were exposed compared to winter and transitional months

6.2.3.2 Impacts to environmental sensitivities

The potential impacts associated with a crude oil release from a well without the use of oil spill response strategies such as chemical dispersion, are provided in Table 6-3.

Table 6-3: Summary of environmental impacts due to a release of Wandoo Crude from a well

Environmental sensitivity	Exposure mechanism	Impact	Consequence classification
Marine habitats			
Corals	Entrained/shoreline	<p>Significant coral reefs within the EMBA include Ningaloo Marine Park, the Montebello/Barrow/Lowendal islands, Shark Bay, Muiron Island, the Dampier Archipelago, Glomar Shoals, Rankin Bank, Mermaid Reef and the Rowley Shoals (Section 4.4.2.2 and Figure 4-3). Ningaloo Marine Park, the Montebello/Barrow/Lowendal islands, Muiron Island, the Dampier Archipelago, Glomar Shoals, Rankin Bank, Mermaid Reef and the Rowley Shoal also occurring within Hydrocarbon Area. No coral reef communities are found in the Operational Area. The nearest area of significant corals reef to the Operational Area being the Glomar Shoals (approximately 37km northeast) and Ningaloo Reef (approximately 250km away). Spill modelling (Appendix 2) predicts that in the event of a loss of well control:</p> <p>No moderate levels of dissolved aromatic hydrocarbons reaching coral reef communities is predicted;</p> <p>High entrained hydrocarbon exposures within 0 to 20 m water depth layer are expected to be limited to Montebello Islands Marine Park.</p> <p>Moderate shoreline accumulation may occur at multiple shoreline receptors predominantly during summer conditions including Rowley Shoals (Clerke Reef, Imperieuse Reef), Lowendal Island, Barrow Island, Mermaid Reef, and Muiron Islands.</p> <p>Direct contact with entrained or shoreline hydrocarbons could lead to chemical toxicity across cellular structure leading to coral bleaching and colony death. Instead of acute mortality, it is more likely that oil effects occur in sub-lethal forms, such as reduced photosynthesis, growth or reproduction (NOAA, 2014). Shoreline hydrocarbon contact is limited to intertidal corals which will be periodically exposed to surface hydrocarbons as well as planktonic stages of corals in particular during periods of coral spawning.</p> <p>Intertidal coral reefs also have the potential for smothering due to shoreline accumulation. As modelling outputs are an aggregate of all potential spill trajectories and therefore it is not credible that all receptors would be exposed at any one time. On this basis, impacts to these areas (including spawning) are likely to be limited and re-colonisation/recovery could be expected over time.</p> <p>In the event of a loss of well control there is a potential for hydrocarbon exposures to result in significant but recoverable (in >1 year) species or habitat damage.</p>	Major (4)
Seagrasses	Entrained/shoreline	<p>The EMBA include seagrass habitats located in waters surrounding Shark Bay, Ningaloo Reef, Dampier Archipelago and Montebello and Barrow islands (Section 4.4.2.3 and Figure 4-3). Within the Hydrocarbon Area Ningaloo Reef, Dampier Archipelago and Montebello and Barrow islands exist. No seagrasses are found within the Operational Area. Noting seagrass species within the EMBA exhibit seasonal trends in abundance and distribution, in response to natural disturbance events and Dugong grazing.</p> <p>Spill modelling (Appendix 2) predicts:</p> <p>Moderate levels of dissolved hydrocarbons are predicted to impact Montebello and Barrow Island seagrass habitats; and</p> <p>High entrained hydrocarbon exposures within 0 to 20 m water depth layer are expected to reach Montebello Islands Marine Park, Shark Bay, Barrow Island MMA and Ningaloo Marine Park.</p> <p>Moderate to high shoreline accumulation may occur at multiple shoreline receptors across all seasons modelled including Barrow Island, Christmas Island and Montebello Islands.</p> <p>Entrained and shoreline hydrocarbons may smother leaves of seagrass beds in shallow intertidal areas. Intertidal seagrass communities would theoretically be the most susceptible because the leaves and rhizomes may both be affected. When seagrass leaves are exposed to oil, sub-lethal quantities of the soluble fraction can be incorporated into the tissue, causing a reduction in tolerance to other stress factors (Zieman et al., 1984). The toxic components of petroleum oils are thought to be the PAH, which are lipophilic and therefore able to pass through lipid membranes and tend to accumulate in the thylakoid membranes of chloroplasts (Ren et al., 1994). In the event of a loss of well control there is a potential for hydrocarbon exposures to result in significant but recoverable species or habitat damage.</p>	Major (4)
Macroalgae	Entrained/shoreline	<p>Macroalgal habitat within the EMBA and Hydrocarbon Areas are widespread throughout shallower areas of the region, particularly where hard substrates occur. There are no specifically identified areas of significant environmental value (Section 4.4.2.4 and Figure 4-3).</p> <p>In the event of a loss of well control and subsequent spill, macroalgae in intertidal areas have the potential to be exposed to in-water and shoreline hydrocarbons. Residues may be left in the area as the tide ebbs, but will be flushed with each flood tide. Studies have shown that macroalgae appear to recover rapidly from oiling, irrespective of the degree of impact and level of oiling. This is attributed to the fact that most of the new algae growth is produced near the base of the plant while distal parts (which would be exposed to the oil contamination) are continually lost (Connell and Miller, 1981).</p> <p>In the event of a loss of well control there is a potential for hydrocarbon exposures to intertidal areas where macroalgae may occur, to result in temporary and recoverable impacts to macro-algal habitats.</p>	Moderate (3)
Mangroves	Shoreline	<p>The shoreline occurring within EMBA and shoreline Hydrocarbon Area includes mangrove habitats located along the Dampier Archipelago, Montebello Islands, Ningaloo coastline and scattered areas along the coast between Onslow and just north of Port Hedland (Section 4.4.3.1 and Figure 4-4). No mangrove communities are found within the Operational Area. The closest regionally significant mangroves to the Operational Area are those occurring within the Dampier Archipelago (greater than 30 km from Operational Area). With notable belts of mangroves occurring between Coral Bay (within shoreline Hydrocarbon Area and approximately 400km from Operational Area) and Eighty Mile Beach (approximately 300km away from Operational Area and within shoreline Hydrocarbon Area).</p> <p>Spill modelling (Appendix 2) predicts low probability of moderate to high shoreline accumulation at Dampier Archipelago, Montebello Islands and the Ningaloo coastline.</p> <p>Observations by Lin and Mendelssohn (1996), demonstrated that more than 1kg/m² of oil during the growing season would be required to impact marsh or mangrove plants significantly. However, mangroves can take more than 30 years to recover from severe oil spill impacts (NOAA, 2014).</p> <p>Subsequently the impact is significant but recoverable species of habitat damage.</p>	Major (4)



Environmental sensitivity	Exposure mechanism	Impact	Consequence classification
Intertidal beaches/mudflats/rocky shorelines/intertidal reef platforms	Shoreline	<p>Intertidal beaches, mudflats, rocky shorelines and reef platforms are widespread throughout the EMBA</p> <p>Three intertidal beach/mudflat areas of international conservation significance occur within the shoreline Hydrocarbon Area (Bandicoot Bay, Eighty Mile Beach and Roebuck Bay) (Section 4.4.3.3 and 4.4.3.4). Notable rocky shorelines and intertidal reef platform areas within the shoreline Hydrocarbon Area occur along the Ningaloo coast and North West Cape (Section 4.4.3.4). No beaches, mudflats, rocky shorelines and reef are within Operational Area.</p> <p>Spill modelling (Appendix 2) predicts that moderate to high shoreline accumulation may occur at Barrow Island (Bandicoot Bay), Eighty Mile Beach, Roebuck Bay, Ningaloo Marine Park and coastline of the North West Cape.</p> <p>Oil has the potential to interfere with infaunal organisms in these areas either by modifying the habitat or smothering the feeding respiratory and/or locomotory structures of these organisms.</p> <p>Hydrocarbons may be left on the intertidal shores as the tide ebbs, but it would be expected that this would be flushed with each flood tide. Natural flushing is more likely to reduce impacts in exposed areas of shoreline.</p> <p>Subsequently the impact is short term localised disruption of ecosystem.</p>	Minor (2)
Sandy beaches	Shoreline	The values associated with sandy beaches are assessed with regard to the following environmental sensitivities: marine reptiles, seabirds and other users (4.4.3.5). Refer to these sections for further detail.	
Protected and threatened species			
Fish and sharks	Dissolved/Entrained	<p>Fish and sharks are expected to be present within the EMBA, in-water Hydrocarbon Area and Operational Area however their presence is generally transient and sporadic (Etkin, 2003). Four species of shark, three sawfish and two rays listed as Threatened or Migratory under the EPBC Act potentially occur in the Operational Area. Seven shark, three sawfish and two ray species which are listed as Threatened or Migratory under the EPBC Act may potentially occur in the Hydrocarbon Area.</p> <p>Within the in-water Hydrocarbon Area, Ningaloo Reef is the main known aggregation area for whale sharks, waters off Exmouth is an identified aggregation area for grey nurse shark and endemic fish communities are found in water depths between 100 m to 300 m in Continental slope demersal fish communities and Western demersal slope KEFs (Section 4.4.4.4). Table 4-6 and Table 4-7 provides details of fish species or species habitat that may occur within the Project Areas.</p> <p>Studies indicate that the dissolved aromatic compounds (typically the mono-aromatic hydrocarbons and the two and three ring poly-aromatic hydrocarbons) are commonly the largest contributor to the toxicity of solutions generated by mixing oil into water (Di Toro et al., 2007).</p> <p>Fish and sharks most likely to be exposed to entrained and dissolved hydrocarbons are pelagic free-swimming fish and sharks as they dwell in the surface layers of the water column (<20 m depth). Some shark species, such as the whale shark, tend to feed close to the surface and may be exposed to the presence of entrained hydrocarbons. A foraging BIA for the whale shark was identified as intersecting with the EMBA, in-water Hydrocarbon Area and Operation Area. Whale sharks are known to routinely move between surface and to depths of >30 m, and in offshore regions can spend most of their time near the seafloor (DSEWPac 2011c). Nursing and foraging BIA for dwarf sawfish, freshwater sawfish and green sawfish was identified within EMBA. Demersal fish within the in-water Hydrocarbon Area are not expected to be impacted given the presence of in-water hydrocarbons is predicted in the surface layers (<20 m depth) only. Pelagic free-swimming fish and sharks exposed to entrained hydrocarbons within the surface layers are unlikely to suffer long-term damage from oil spill exposure because in-water hydrocarbons are typically insufficient to cause harm (ITOPF 2011). Pelagic species are also generally highly mobile and as such are not likely to suffer extended exposure (e.g. >40–96 hours) at concentrations that would lead to chronic effects due to their patterns of movement, therefore fish and shark kills as a result of a spill in open water are unlikely.</p> <p>The larval stages of fish species are more likely to be susceptible; however, in comparison to predation and natural loss, any impacts would be over a small proportion of the marine environment in which they may occur and any measurable impact at the population level is likely to be low. In addition, fish mortality from oil spills is rarely reported and it is unlikely that significant population level impacts will occur.</p> <p>Consequently, the spill is only expected to cause a very localised disruption of behaviours/ecosystem.</p>	Minor (2)



Environmental sensitivity	Exposure mechanism	Impact	Consequence classification
Marine mammals	Dissolved/ Entrained	<p>Marine mammals may be present within the EMBA, Hydrocarbon Area and Operational Area during the Petroleum Activity and impacted by dissolved/ entrained hydrocarbons (Table 4-8). However, the presence of most species is expected to be of a transitory nature only, with a small number of species having an important behaviour (e.g. foraging, breeding) identified within the Hydrocarbon Area. Cetaceans listed as Threatened or Migratory under the EPBC Act may potentially occur in the EMBA and in-water Hydrocarbon Area (Section 4.4.4.5 and Table 4-8). The migration BIA for the humpback whale, and distribution BIA for the pygmy blue whale are located with the in-water Hydrocarbon Area and Operations Area. dolphins are also known to occur and transit through the EMBA and Hydrocarbon Area.</p> <p>Marine mammals can be exposed to oil externally (e.g. swimming through oil) or internally (e.g. swallowing the oil, consuming oil affected prey, or inhaling of volatile oil related compounds). Impacts from ingested oil and subsequent lethal or sub-lethal toxicity are possible; however, the susceptibility of cetaceans varies with feeding habits. Toothed whales and dolphins gulp feed at depth (and are therefore less likely to be exposed to entrained/dissolved oil given its presence in surface water layers (<20 m) only). While mammals do not appear to exhibit avoidance behaviours, as highly mobile species, in general it is very unlikely that these animals will be constantly exposed to concentrations of hydrocarbons for continuous durations (e.g. >48–96 hours) that would lead to chronic effects.</p> <p>Some whales, particularly those with coastal migration and reproduction, display strong site fidelity to specific resting, breeding and feeding habitats, as well as to their migratory paths. There are migratory and distribution BIAs identified for humpback whales and pygmy blue whales, respectively. Oil in biologically important habitats may disrupt natural behaviours, displace animals, reduce foraging or reproductive success rates and increase mortality.</p> <p>Dugongs may occur within EMBA and Hydrocarbon Area with Breeding, calving, nursing and foraging grounds within the Exmouth Gulf and North West Cape regions. Presence may occur throughout the year. Presence in Shark Bay BIAs may be more seasonal, between April and November. Shark Bay falling within the EMBA and shoreline Hydrocarbon Area. Dugongs may also ingest oil (directly, or indirectly via oil-affected seagrass), and depending on the amount and type of oil, the effects could be short-term to long-term/chronic (e.g. organ damage). However, it is noted that reports on oil pollution damage to dugongs is rare (ITOPF 2014).</p> <p>Entrained and dissolved oil components may persist for periods of time; however, the duration of exposure is still expected to be limited.</p> <p>Given the predominantly transient nature of any presence of marine mammals within the in-water Hydrocarbon Area, any impact that did occur would be at an individual and not a population level for any receptor group. For those species where aggregations may occur (e.g. in BIAs), they are typically seasonal. Recovery of any impacted water column associated receptors is expected to occur.</p> <p>Given that the area of potential impact is relatively small in relation to the offshore environment, and cetaceans and other marine mammals would be transitory, any interface with in-water hydrocarbons is unlikely to cause an impact to significant numbers. However, there is potential for exposure to individual cetaceans and other protected fauna species, hence the impact is classified as major.</p>	N/A
	Surface	<p>Marine mammals may be present within the EMBA, Hydrocarbon Area and Operational Area during the Petroleum Activity and impacted by surface hydrocarbons (Table 4-8).</p> <p>Modelling also predicts that moderate and high surface hydrocarbon exposures have the potential to extend across the EMBA including the migration and distribution BIAs for the humpback whale and pygmy blue whale, respectively. It is possible for whales to be exposed to surface hydrocarbons if the hydrocarbon release occurs during the migration period. Marine mammals are also likely to encounter surface oil as they return to the surface to breathe and baleen whales feed by surface skimming. However, short-term inhalation of petroleum vapours or ingestion of surface hydrocarbons at concentrations similar to those found in oceanic spills may not be detrimental either in terms of structural tissue damage or respiratory gas exchange. Cetaceans are smooth skinned hairless mammals, so oil tends not to stick to their skin since they do not rely on fur for insulation, hence they will not be sensitive to the physical effects of oiling.</p> <p>Given that the area of potential impact is relatively small in relation to the offshore environment, and cetaceans and other marine mammals would be transitory, any interface with hydrocarbons is unlikely to cause an impact to significant numbers. However, there is potential for exposure to individual cetaceans and other protected fauna species, hence the impact is classified as major.</p>	Major (4)
	Shoreline	<p>Marine mammals are expected to be present within the EMBA and Hydrocarbon Area shoreline during the Petroleum Activity (Table 4-8). Shorelines do not occur within Operational Area.</p> <p>Oiling of pinnipeds (seals and sea lions) can cause removal of natural water repellent oils from their fur making them less buoyant and susceptible to hypothermia (Kucklick, 1997). However, given that oil will be significantly weathered and dispersed by the time it reaches the pinniped habitats, it is unlikely to result in significant exposure to a large population.</p> <p>The highest potential risks for dugongs are related to direct ingestion of seagrass or macroalgae exposed to acute or chronic toxicity and or drastic reduction on seagrass coverage due to hydrocarbon spills (Heinsohn et al., 1977). However, as explained for these receptors, impacts are unlikely to be extensive and are recoverable.</p> <p>Given that oil will be significantly weathered and dispersed by the time it reaches the pinniped or dugong habitats, any interface with hydrocarbons is unlikely to cause an impact to significant numbers. However, there is potential for exposure to individual protected fauna species, hence the impact is classified as major.</p>	Major (4)



Environmental sensitivity	Exposure mechanism	Impact	Consequence classification
Marine reptiles (turtles and sea snakes)	Surface	<p>Marine turtles may be present within the EMBA, Hydrocarbon Area and Operational Area during the Petroleum Activity and impacted by surface hydrocarbons (Table 4-10). The presence of most marine reptile species within the Hydrocarbon Area and Operational Area are expected to be of a transitory nature only.</p> <p>Species of sea snakes and marine turtles are known to occur in the Hydrocarbon Area.</p> <p>There are a number of BIAs for turtle species (flatback, green, hawksbill, loggerhead) that occur within the Hydrocarbon Area (Table 4-11). An internesting flatback turtle BIAs exist within Operational Area, based around nesting locations within the Dampier Archipelago (30km from Operational Area) however flatback, green, hawksbill, loggerhead may occur in transit.</p> <p>Two species of sea snake listed as Protected may occur in the EMBA; Short-nosed Sea snake and Leaf-scaled Sea snake. The short-nosed sea snake may occur within the Operational Area however prefers the reef flats or shallow waters along outer reef edges in water depths to 10 m and generally stay within 50 m of the reef. The leaf-scaled sea snake occurs on the reefs of the with Sahul Shelf in Western Australia, particularly on Ashmore and Hibernia Reefs within the EMBA.</p> <p>Spill modelling results predicts low potential for moderate surface hydrocarbon exposures in these areas in the event of a loss of containment from an operating well (Appendix 2). Marine reptiles are likely to come in contact with oil in the event of a spill as they surface to breathe. Marine turtles can be exposed to oil externally (e.g. swimming through oil slicks) or internally (e.g. swallowing the oil, consuming oil affected prey, or inhaling of volatile oil related compounds). Several aspects of turtle biology and behaviour place them at particular risk, including a lack of avoidance (NOAA 2010b) and large pre-dive inhalations (Milton and Lutz 2003). Harmful effects may occur through ingestion of oil, inhalation of toxic vapours (e.g. close to the spill source) or irritation to the head, neck and flippers due to oil contact with the skin. Within the immediate vicinity of the spill event, where hydrocarbons are still fresh, this could lead to fatal impacts on individuals. No confirmed reports of impacts to marine wildlife were received or surveyed during the Montara oil spill scientific monitoring studies (UniQuest 2010). Given the presence of marine reptiles in the Hydrocarbon Area are expected to be transitory, the exposure of marine reptiles to surface hydrocarbons is unlikely to have a population effect. Subsequently the potential impact is single fatalities of protected species; hence the impact is classified as major.</p>	Major (4)
	Shoreline	<p>Marine turtles and sea snakes may be present within the EMBA and Hydrocarbon Area shorelines during the Petroleum Activity and impacted by shoreline hydrocarbons (Table 4-11). The Hydrocarbon Area contains shoreline habitats critical to the survival of marine turtles where genetic stocks are present (Section 4.4.4.6). Critical shoreline habitats for marine turtles within the Hydrocarbon Area are listed in Table 4-10.</p> <p>Spill modelling results indicate that moderate to high shoreline accumulation may occur at nesting locations critical to the survival of marine turtles (Appendix 2). Shallow water habitats key to nesting and inter-nesting sites occur within Dampier Archipelago, Ningaloo Reef and offshore islands (e.g. Barrow Island, Montebello Islands) occur within Hydrocarbon Area (Table 4-12).</p> <p>In the unlikely event that hydrocarbons did accumulate at a turtle nesting area, there is potential for adult turtles and/or hatchlings to be impacted within Hydrocarbon Areas. Potential impacts include smothering of adults and hatchling and/or avoidance behaviour of adult turtles. This could result in failed or aborted nesting attempts or a reduction in survival rates of hatchlings.</p> <p>As many turtle species do not nest exclusively within a single area, and as all of these areas would not be impacted for this scenario, the impact is unlikely to affect the viability of the species, but may result in a significant but recoverable impact to the population if hatchlings over a season are impacted. Sea snakes occurring on reef systems within shoreline Hydrocarbon Area may be impacted. As there is a potential for more than a single protected species fatality the impact is classified as Major.</p>	Major (4)

Environmental sensitivity	Exposure mechanism	Impact	Consequence classification
Birds	Surface	<p>There are multiple species (or species habitat) of birds that may occur within the EMBA, Hydrocarbon Area and Operational Area (The wedge-tailed shearwater is a migratory visitor to WA and may occur within the EMBA and Hydrocarbon Area (Table 4-4). Estimates indicate more than one million shearwaters migrate to the Pilbara islands each year (DBCA 2017). The wedge-tailed shearwater will excavate burrows on vegetated islands for nesting. Known breeding locations in the North-west Marine Region. Breeding locations within the Hydrocarbon Area include Forestier Island (Sable Island), Bedout Island, Dampier Archipelago, Passage Island, Lowendal Island, islands off Barrow Island (Mushroom, Double and Boodie Islands), islands in the Onslow area (including Airlie, Bessieres, Serrurier, North and South Muiron and Locker Islands) (DEWHA 2008a) Breeding locations within the broader EMBA are inclusive of those with Hydrocarbon Area as well as islands in the Freycinet Estuary, and south Shark Bay (Slope, Friday, Lefebvre, Charlie, Freycinet, Double and Baudin Islands) (DEWHA 2008a).</p> <p>The fairy, lesser crested and roseate terns may have both a resident sub-population and a migratory population present in the Pilbara (DBCA 2017). These tern species nest in open areas, typically sand scrapes/depressions on the sandy beaches of offshore islands. Within the EMBA these tern species are known to nest within the region of the Ningaloo Marine Park, Muiron and Sunday islands (CALM 2005). The Montebello Islands support the largest breeding population of roseate terns in WA (DEWHA 2008). Ningaloo Marine Park, Muiron and Sunday islands, and Montebello Islands occur within the Hydrocarbon Area.</p> <p>Caspian terns, little terns, and ospreys have also been known to breed on Serrurier Island and neighbouring inshore islands (DEWHA 2008) within the Hydrocarbon Area.</p> <p>Bedout Island (offshore from Port Hedland and within the Hydrocarbon Area) supports one of the largest colonies of brown booby in WA (Figure 4-9); the masked booby, lesser frigatebird, roseate tern and common nobby also breed in the area (DEWHA 2008).</p> <p>Tropicbird species spend most of their lives at sea, typically found in tropical and subtropical seas around northern Australia. A small sand cay at Bedwell Island, within Clerke Reef in Rowley Shoals Marine Park, is one of very few breeding areas in Western Australia for the Red-tailed tropicbird. Both locations occurring within the Hydrocarbon Area (Table 4-4). The presence of most species, particularly within the Operational Area, are expected to be of a transitory nature only.</p> <p>A number of threatened and migratory birds may occur in parts of the EMBA where moderate and high surface hydrocarbons are predicted (Section 4.4.4.3 and Appendix 2) and include areas with recognised offshore foraging BIAs for seabird species listed in Table 4-5.</p> <p>Scholten et al., 1996 indicates that a layer of 25µm thick would be harmful to birds that contact the slick. Estimates for the minimal thickness of oil that will result in harm to seabirds through ingestion from preening of contaminated feathers, or the loss of thermal protection of their feathers, has been estimated at 10µm (French, 2009) to 25µm (Koops et al., 2004).</p> <p>Oil spills can have a variety of effects including fouling of the plumage, ingestion of oil, effects on reproduction and physical disturbance. Many of the species that occur offshore are surface-feeding or plunge-diving pelagic birds, so that oil slicks would potentially interfere with feeding and increase exposure risk.</p> <p>Seabirds are expected to be present within parts of the EMBA where moderate and high surface hydrocarbons are predicted but their presence is expected to be transient. Hence population level impacts are unlikely, but mortality of protected seabirds may occur.</p>	Major (4)
	Shoreline	<p>Bird species (or habitat) may occur within the EMBA and Hydrocarbon Area shoreline areas (Table 4-4). The presence of most species are expected to be of a transitory nature only. Shorelines do not occur within Operational Area.</p> <p>A number of threatened and migratory birds may occur within the shoreline Hydrocarbon Area. The Hydrocarbon Area contains recognised onshore breeding and resting BIAs for seabird species listed in Table 4-5. Important seabird breeding sites within the region include the Montebello/Barrow islands group, Rowley Shoals, Eighty Mile Beach and Roebuck Bay. All areas are within the EMBA and Hydrocarbon Area (Section 4.4.4.3).</p> <p>Given these shorelines provide habitat for a range of species, a large number of seabird mortalities may potentially occur if an oil spill reaches these areas during critical periods. Given all areas will not be impacted, the impacts are not likely to affect species viability, the impact is classified as Major.</p>	Major (4)
Socio-economic receptors			
Commonwealth and State Managed Fisheries and Aquaculture	Surface/entrained	<p>There are a number of Commonwealth and State fisheries with management areas that intersect the EMBA and Hydrocarbon Area (Section 4.5.1.1, 4.5.1.2). Commonwealth managed fisheries (Table 4-15) and State managed (Table 4-16) may be a relevant receptor to aspects of the activity occurring within the Operational Area; however it is unlikely that fishing activity will occur in the Operational Area due to the restricted zones. No Aquaculture projects exist within Operational Area. Within the EMBA, the low threshold for floating oil and shoreline contact has potential for some socioeconomic impacts (NOPSEMA 2019), however these impacts are expected to be temporary.</p> <p>In the event of a significant oil spill, surface oil is less likely to result in direct impacts to the fish but may interfere with fishing operations through damage to vessels and fishing gear, exclusion to areas during clean-up operations and any follow-up monitoring and surveillance activities. There is also a potential that perceptions of fish tainting due to the spill could indirectly result in economic impacts to the fishery.</p> <p>Fish species themselves, are more likely to be impacted by in-water hydrocarbons as they dwell in the water column. Refer also to impact assessments for related receptors, including fish and sharks.</p> <p>Tainting is a change in the characteristic smell or flavour of fish and may be due to oil being taken up by the tissues or contaminating the surface catch (McIntyre et al 1982). Taint in seafood renders it unfit for human consumption or unsellable due to public perception. Tainting may not be a permanent condition but will persist if the organisms are continuously exposed; but when exposure is terminated, depuration will quickly occur (McIntyre et al 1982).</p> <p>A major oil spill may result in the temporary closure of part of fishery management areas. It is unlikely that a complete fishery would be closed due to their large spatial extents, but the partial closure may still displace fishing effort. Given all areas will not be impacted, the impacts are expected to be limited to temporary closures, the impact is classified as moderate.</p>	Moderate (3)

Environmental sensitivity	Exposure mechanism	Impact	Consequence classification
Commercial Shipping	Surface	Commercial shipping may be a relevant receptor to aspects of the activity occurring within the EMBA, Hydrocarbon Area and Operational Area during the Petroleum Activity. The Operational Area is approximately 25km from the northbound shipping fairway from Dampier (Figure 4-21). There are significant commercial shipping activities within the EMBA and Hydrocarbon Area (4.5.2). The impact on shipping in the event of a well blowout is potential modification of shipping routes to avoid the area affected. Given all areas will not be impacted and impacts are expected to be limited to temporary exclusion of area affected, the impact is classified as minor.	Minor (2)
Other users	Surface	A number of tourist destinations occur within the EMBA and Hydrocarbon Area, and include the Ningaloo Coast (Section 4.5.4.2). However, none occur within Operational Area. Within the EMBA, the low threshold for floating oil and shoreline contact has potential for some socioeconomic impacts (NOPSEMA 2019), however these impacts are expected to be temporary. In the event of a loss of well, there is the potential for temporary changes to socio-economic users occurring within the EMBA. Depending on the fate and trajectory of the oil, tourism activities which could have a temporary impact to the tourism industry. As persistent hydrocarbons are likely to dissipate from the environment over time, and as the volumes ashore suggest remediation may be difficult or expensive, impacts are expected to be extensive but temporary. More broadly in the region, the impacts to humans and the activities themselves are not likely to be significant; however, there is the potential for temporary closure of recreational activities, including diving, for risk to public health and safety. This would be short term and limited to the area immediately affected by a spill. There is a possibility of impacts to tourism operators due to actual or perceived impacts to aesthetics and the regional marine resources by the general public through negative media attention. Any closures would be short term in nature, as entrained hydrocarbons will naturally disperse, and any shoreline accumulation would breakdown due to natural weathering processes. As such, potential impacts are considered to be extensive but temporary.	Moderate (3)
Protected areas			
World Heritage Areas	Surface/ shoreline/ entrained	The Ningaloo Coast WHA and Shark Bay WHA occur within the EMBA (Section 4.6.1) may be impacted in the event of a well blowout. However, the Hydrocarbon Area only encompasses Ningaloo Coast WHA. The values associated with Ningaloo Coast WHA and Shark Bay WHA has been assessed in terms of the protected/threatened species and marine habitat and socioeconomic receptor sections outlined above.	As above
Australian Marine Parks	Surface/ shoreline/ entrained	Australian Marine Parks located within the EMBA and Hydrocarbon Area are listed in Table 4-23. There are no Australian Marine Parks within the Operational Area. The values associated with Australian Marine Parks have been assessed in terms of the protected/threatened species and marine habitat and socio-economic receptor sections outlined above.	As above
State Marine Protected Area	Surface/ shoreline/ entrained	State Marine Reserves located within the EMBA and Hydrocarbon Area are listed in Table 4-25. There are no State Marine Protected Area within the Operational Area. The values associated with State Marine protected areas have been assessed in terms of the protected/threatened species and marine habitat and socio-economic receptor sections outlined above.	As above
Ramsar Wetlands	Surface/ shoreline/ entrained	Eighty-mile beach Ramsar site is located within the EMBA and Hydrocarbon Area The values associated with Eighty-mile beach Ramsar site has been assessed in terms of the protected/threatened species and marine habitat and socio-economic receptor sections outlined above.	As above
Key ecological features			
Ancient coastline at 125m depth contour	No exposure	The EMBA and Hydrocarbon Area overlaps the Ancient coastline at 125 m depth contour. However, modelling of in-water hydrocarbons was predicted to be limited to surface water depths of 0 to 20 m (Appendix 2). Subsequently there will be no hydrocarbon exposure to the seabed values of this KEF.	No exposure
Canyons linking the Cuvier Abyssal Plain and the Cape Range Peninsula	Entrained	The EMBA and Hydrocarbon Area overlaps the Canyons linking the Cuvier Abyssal Plain and the Cape Range Peninsula KEF. However, modelling of in-water hydrocarbons was predicted to be limited to surface water depths of 0 to 20 m (Appendix 2). Subsequently there will be no hydrocarbon exposure to the sub-bottom habitat values of this KEF. There is potential for marine mammals, reptiles and seabirds transiting the KEF to be exposed moderate levels of entrained hydrocarbons. Potential impacts of Wandoo Crude on marine mammals, reptiles and seabirds are outlined above.	Moderate (3)
Commonwealth Waters adjacent to Ningaloo Reef	Surface	The EMBA and Hydrocarbon Area overlaps the Commonwealth Waters adjacent to Ningaloo Reef KEF. There is potential for intertidal reefs in the area to be exposed to moderate levels of entrained and shoreline hydrocarbons. Potential impacts of Wandoo Crude on corals are outlined above. There is potential for marine mammals, reptiles and seabirds transiting the area to be exposed to moderate levels of entrained and surface hydrocarbons. Potential impacts of Wandoo Crude on marine mammals, reptiles and seabirds are outlined above.	Moderate (3)
Continental slope demersal fish communities	Surface	The EMBA and Hydrocarbon Area overlaps the continental slope demersal fish communities KEF. Demersal fish communities associated with this KEF are found in water depths between 100 to 300 m (Section 4.4.4.4). Modelling of in-water hydrocarbons was predicted to be limited to surface water depths of 0 to 20 m (Appendix 2). Subsequently there will be no hydrocarbon exposure to the demersal fish communities values of this KEF. However commercial fishing operations within the area may be affected by exclusion zones in the event of a spill. Potential impacts of Wandoo Crude on commercial fisheries are outlined above.	Moderate (3)
Western demersal slope	No exposure	The Western demersal slope KEF occurs within the EMBA but is not located in the Hydrocarbon Area. The values of this KEF are not exposed to levels of hydrocarbons that will illicit an impact.	No exposure
Exmouth Plateau	No exposure	The EMBA and Hydrocarbon Area overlaps the Exmouth Plateau. The Exmouth Plateau lies at water depth of approximately 500 m to more than 5,000 m. Modelling of in-water hydrocarbons was predicted to be limited to surface water depths of 0 to 20 m (Appendix 2). There will be no exposure to Wandoo Crude at these depths. Subsequently there will be no hydrocarbon exposure to the seabed values of this KEF.	No exposure

Environmental sensitivity	Exposure mechanism	Impact	Consequence classification
Glomar Shoals	Surface	The Glomar Shoals KEF lies within the EMBA and Hydrocarbon Area. Modelling of in-water hydrocarbons was predicted to be limited to surface water depths of 0 to 20 m (Appendix 2). The Glomar Shoals are a submerged littoral feature in water depths of 33 – 77 m. Subsequently there will be no hydrocarbon exposure to the values of this KEF. However commercial fishing operations within the area may be affected by exclusion zones in the event of a spill. Potential impacts of Wandoo Crude on commercial fisheries are outlined above.	Moderate (3)
Mermaid Reef and Commonwealth Waters surrounding Rowley Shoals	Surface	Mermaid Reef and Commonwealth Waters surrounding Rowley Shoals KEF is located within the EMBA and Hydrocarbon Area. There is potential for intertidal reefs in the area to be exposed to moderate levels of entrained and surface hydrocarbons. There is potential for marine mammals, reptiles and seabirds transiting the area to be exposed to zones of low and medium sea surface exposure. Potential impacts of Wandoo Crude on marine mammals, reptiles and seabirds are outlined above.	Major (4)
Wallaby Saddle	No exposure	Wallaby Saddle is an area of seafloor in 4,000 m to 4,700 m water depths located within the EMBA but outside of the Hydrocarbon Area. Modelling of in-water hydrocarbons was predicted to be limited to surface water depths of 0 to 20 m (Appendix 2). There will be no exposure to Wandoo Crude at these depths.	No exposure
Ancient coastline at 90m to 120m depth	No exposure	The Ancient coastline at 90 m to 120 m depth is located within the EMBA but outside of the Hydrocarbon Area., hence there will be no hydrocarbon exposure to values of this KEF that will illicit potential ecological impacts.	No exposure
Commonwealth marine environment surrounding Houtman Abrolhos Islands	No exposure	The Commonwealth marine environment surrounding Houtman Abrolhos Islands KEF lies within the EMBA but outside of the Hydrocarbon Area, hence there will be no hydrocarbon exposure to values of this KEF that will illicit potential ecological impacts.	No exposure
Perth Canyon and adjacent shelf break and other west coast canyons	No exposure	The Perth Canyon and adjacent shelf break and other west coast canyons KEF lies within the EMBA but outside of the Hydrocarbon Area, hence there will be no hydrocarbon exposure to values of this KEF that will illicit potential ecological impacts.	No exposure
Western rock lobster	No exposure	The Western rock lobster KEF lies within the EMBA but outside of the Hydrocarbon Area, hence there will be no hydrocarbon exposure to values of this KEF that will illicit potential ecological impacts.	No exposure
Commonwealth marine environment adjacent to the west coast inshore lagoons	No exposure	The Commonwealth marine environment adjacent to the west coast inshore lagoons KEF lies within the EMBA but outside of the Hydrocarbon Area, hence there will be no hydrocarbon exposure to values of this KEF that will illicit potential ecological impacts.	No exposure
Ashmore Reef and Cartier Island	No exposure	The Ashmore Reef and Cartier Island surrounding Commonwealth waters lies within the EMBA but outside of the Hydrocarbon Area (Section 4.5.5.16), hence there will be no hydrocarbon exposure to values of this KEF that will illicit potential ecological impacts.	No exposure
Canyons linking Argo Abyssal Plain with Scott Plateau	No exposure	The Canyons linking Argo Abyssal Plain with Scott Plateau KEF lies within the EMBA but outside of the Hydrocarbon Area, hence there will be no hydrocarbon exposure to values of this KEF that will illicit potential ecological impacts.	No exposure
Seringapatam Reef and Commonwealth waters of the Scott Reef Complex	No exposure	The Seringapatam Reef and Commonwealth waters of the Scott Reef Complex lies within the EMBA but outside of the Hydrocarbon Area, hence there will be no hydrocarbon exposure to values of this KEF that will illicit potential ecological impacts.	No exposure

6.2.4 Catastrophic Environmental Event identification

The identified CEE is designated as CEE-01 – Production well blowout.

6.2.5 Critical Controls identification

In accordance with the process described in Section 5.4.2 all controls for CEE-01 – Production well blowout have been assessed for criticality. This assessment has resulted in a concise listing of identified Critical Controls as provided in Table 6-4.

Table 6-4: CEE-01 Critical Controls

Hazard	Activity/Cause/Mitigation	Critical Control
CEE-01 Production well blowout	Well intervention operation. Rigless well intervention – SL/electric line/coiled tubing/hydraulic workover/well pumping operations. Entering into production well.	Primary well control systems.
		Secondary well control equipment.
		Well barrier envelope
		Well Construction Management System
	Loss of barrier envelope.	Well design
		Instrument protective and alarm systems.
		Well Integrity Manual
		Work Management Manual Section 4 (Isolating and Reinstating)
	Human error.	Permit to work system.
		Contractor/vendor selection and management.
	Vessel collision.	Navigation aids.
		CALM Buoy Mooring System
		Emergency communications.
	Structural failure.	Structures (Super- and Substructures)
		Structural Integrity Manual
	Dropped object/swinging load.	Crane Operations, Maintenance and Inspection Manual
Mitigation.	Shutdown System	
	Wandoo Emergency Response Plan [VOG-2000- RD-0017]/ Source Control Contingency Plan [WNB-3000-PD-0007]/ Wandoo Field OSCP [WAN-2000-RD-0001].	

6.2.6 Mitigation measures

Mitigation measures associated with a loss of well control centre around two primary activities: those focused on stopping flow from the well, source control; and those focused on protecting the environment from the impact of the spilt hydrocarbons.

6.2.6.1 Source Control

The management of resources, information and communications via the implementation of established procedures is absolutely essential for effective emergency response in order to ensure protection of life, property and the environment.

VOGA has a Source Control Contingency Plan [WNB-3000-PD-0007] and an associated preliminary Relief Well Basis of Design in place. This provides a guideline to the required response and event hierarchy to a well control event, either contained or uncontained and the processes that shall be followed in the event of a well control incident during operations in the Wandoo Field. The acceptability of the VOGA Source Control Contingency Plan has been demonstrated in the Wandoo Well Operations Management Plan [VOG-1000-YG-0006] which has been accepted by NOPSEMA.

The VOGA Source Control Contingency Plan identifies that if a loss of well control cannot be controlled via secondary well control procedures, well fluids may continue to be released until a relief well is drilled.

Plans for drilling a relief well will begin in parallel to progressing other well intervention options aimed to stop the flow of hydrocarbon or to permanently secure the primary well. Subsea well capping is not a viable option for stemming the flow of a well blow out at Wandoo, due to blowouts occurring at the sea surface.

In the event of an uncontrolled surface blowout, unless the well kills itself via bridging off or reservoir depletion, the well is killed by means of dynamic kill (i.e. relief well) or some form of surface intervention. If well integrity is intact and access to the wellhead is possible, a surface intervention operation may be attempted in parallel while a relief well is drilled. The relief well kill technique may also be combined with plugging materials for highly prolific blowouts. This technique was used in Argentina in 1993, where a high rate gas blowout was killed by simultaneously pumping through the drill pipe (snubbed into the blowout well), and the relief well annulus. These options would be explored at the time of the spill based on the type of blow-out and the ability for personnel to safely attempt surface intervention techniques.

VOGA has contracted Wild Well Control Inc. to support the management of any well control incident occurring in VOGA's operations and to provide technical assistance and specialised firefighting equipment and personnel. VOGA also has service agreements in place with specialists for the purposes of dynamic well kill modelling and engineering.

A relief well will intersect the uncontrolled zones from the primary well and specialised plugging fluids will be pumped into the well to overcome the reservoir pressure. Well kill modelling will be conducted to confirm the fluid rates, pump rates and volumes that will be required to maintain integrity of the primary bore.

The relief well preliminary basis of design in the VOGA Source Control Contingency Plan identifies and details two options for suitable relief well locations that consider expected surface oil and flammable vapour clouds.

Gas dispersion modelling identified that the potential for gas levels to build up sufficiently to threaten safe operational levels was very low, regardless of distance from the surface location of the blowout. On this basis the primary consideration for rig positioning for the relief well is the prevailing currents responsible for the direction in which an oil slick would progress. This drove the selection of the two preliminary relief well surface locations in order to minimise the potential

for the build-up of oil slick beneath the rig. In the event of an actual blowout event, more detailed gas dispersion modelling will be conducted to finalise the relief well location based on the prevailing metocean conditions.

In the event a relief well is required, VOGA will mobilise an appropriate MODU from local or international sources that has the required specifications to drill a relief well and regain control over the well that is blowing out.

The process associated with planning and drilling of a relief well if required is estimated to take 78 days. This is based on estimates for the following key tasks (days after event):

- event reported and begin mobilisation of rig for relief well drilling – 1 day.
- well design and engineering completed – 30 days
- relief well rig onsite (via NWS or SE Asia) –35 days.
- regulatory submissions and approvals – 50 days
- spud and drill relief well to intersect wellbore and bottom kill well to control source – 78 days.

VOGA has reviewed the schedule of source control activities and is unable to reduce timing to a point where spill duration can be reduced to below 78 days, see Section 6.2.8.

The VOGA Source Control Contingency Plan is reviewed for adequacy prior to each heavy well intervention (HWI) and drilling campaign for wells capable of sustaining natural flow to ensure any relevant well specific considerations, technical studies and timing considerations for a relief well are addressed to ensure its applicability. This includes an assessment of flow rate and duration of new wells using reservoir simulation modelling to ensure that the flow rate and duration of a blowout remain within the worst-case discharge parameters identified in this EP. If the assessment indicates the potential for worst case discharge parameters to be exceeded, the management of change process will be undertaken in accordance with Section 7.8 which includes a review of regulatory compliance.

Suitable rigs are identified at the time of reviewing the Source Control Plan, and VOGA tracks the MODU activity within the region and updates the register on a monthly basis during heavy well intervention (HWI) operations for wells capable of sustaining natural flow to surface.

6.2.6.2 Spill Response

The response strategies to reduce the environmental impact from this hazard scenario are outlined within Section 6.5 and are implemented through the Wandoo Field OSCP [WAN-2000-RD-0001]. These response strategies are consistent with those outlined in the National Plan and have been determined through VOGA's spill preparedness planning process, described in Section 7.9

The planning process results provide an effective mitigation of the environmental impacts of this hazard scenario by identifying suitable spill response strategies which:

- are appropriate for the hazard profile
- consider the benefits of each strategy and
- consider the risks and impacts of each strategy

The Oil Pollution Plan (OPP) 2 for this category of spill is based on potential impacts to a number of sensitive shorelines. These priorities will be verified in a response with real time trajectory data and analysis of seasonal vulnerabilities through the SIMA process. For planning purposes, they present as the protection priorities for the initial OPP and first series of IAPs. On this basis, the response strategies proposed for this hazard include:

- monitor and evaluation;
- chemical dispersion;
- containment and recovery;
- mechanical dispersion;
- protection and deflection; and
- shoreline clean-up.

The impact profile of the spill hazard and subsequent response strategy is reflected in an objective for the response strategy. These outcomes align with the VOGA Critical Procedure Performance Standard for Element 8 – Oil Spill Response [WAN-WNAB-CP-ER-02 and WAN-WNAB-CP-ER-03] key requirements (detailed in Appendix 5). The resources required to achieve the objective were defined and based on:

- operational limitations, e.g. metocean conditions, equipment functional capacity/coverage, safety of response personnel;
- constraints of equipment effectiveness;
- scale of hazardous event including:
 - when and where the resource would be required, based on the results of consequence modelling (e.g. time to impact, thresholds and probability);
 - duration of resource use;
 - ancillary resources required to support primary response option;
 - skill-sets required for specific roles (e.g. shoreline survey and assessment, offshore boom and skimmer operation, aerial observation);
- logistical considerations including:
 - location and size of stockpiles available to VOGA;
 - mobilisation times;
 - logistical requirements for safe deployment of materials and equipment;
- the review allowed for the stockpile locations and availability to be verified for the Australian Marine Oil Spill Centre (AMOSC), Australian Maritime Safety Authority (AMSA) and Oil Spill Response Ltd (OSRL) stockpiles;
- existing service provider contracts to be reviewed and resources available updated; and
- ALARP review to assess options to further improve delivery of response strategy objective.

An assessment of the benefits of the oil spill response strategies that are considered feasible for application in response to a spill of this nature is provided in Table 6-5. The impacts of the oil spill response strategies are assessed in Section 6.5. The impacts outlined in this section were

considered in the strategy selection process. The response strategies will be implemented in accordance with the Wandoo Field OSCP [WAN-2000-RD-0001].



Table -6-5: Feasibility and benefits of response strategies for a Category E spill

Response strategy	Feasible	Benefits
Monitor and evaluate	Yes	Monitoring and evaluation provides up-to-date information on the behaviour and likely trajectory of the spill. This will be used to select the most appropriate response strategy and to evaluate its effectiveness.
Chemical dispersion	Yes	<p>Chemical dispersion assists with the natural dispersion process encouraging the slick to mix and suspend within the water column where it can be more easily biodegraded. Laboratory results show that chemical dispersant is effective on weathered and unweathered samples of Wandoo Crude and that dispersant can achieve an efficacy of up to 100% if used in the first three days of weathered oil (ChemCentre 2015). OSTM for this scenario was undertaken with and without the application of dispersant for the worst-case model runs. The OSTM examined the potential benefit of applying surface dispersant as a mitigation measure (referred to as the mitigated case). The benefit of reducing the volume of surface oil against the potential impacts of increasing the volume of subsurface oil and the introduction of dispersants into the environment was assessed based on the OSTM results. Based on an analysis of the OSTM results provided in (Appendix 3), it was concluded that:</p> <p>For area of surface oil: The maximum distance from the release location to the low (1-10 g/ m²), and moderate (10-50 g/ m²) exposure thresholds was 922 km and 186 km west-northwest (summer), respectively for the unmitigated case. For the mitigated case the maximum distance was 341 km and 6km. No high exposure was predicted for any of the spill trajectories in the unmitigated or mitigated cases.</p> <p>For length of shoreline contact: For all seasons, the modelling demonstrated a reduction in the length of shoreline contact (above 10 g/ m²), when the surface dispersant was applied. For the unmitigated case, at, or above, the low threshold (10 g/ m²) during the summer, transitional and winter seasons was 71 km, 28 km and 17 km, respectively, compared to 20 km, 7 km, 9 km for the mitigated case, or a reduction of 72%, 75% and 47%, respectively.</p> <p>The greatest volume of oil on shore from a single spill trajectory was predicted to reduce from 303 m³, to 52 m³ when the mitigation option was considered. This represented a reduction of 82%.</p> <p>The probability of dispersants reducing the net environmental impacts of the spill will be assessed if shoreline contact is predicted. Regardless of season, a dispersant test spray run will be carried out to verify its effectiveness prior to moving to full dispersant application operations.</p>
Containment and recovery	Yes	<p>Containment and recovery can be used to recover oil to prevent it impacting on environmental, social and cultural sensitivities. The effectiveness of containment and recovery depends on the thickness of the oil and weather and sea-state conditions. Containment and recovery may be effective on Wandoo Crude as it is a persistent crude oil with a high specific gravity and viscosity. OSTM results show that there a probability of sensitive marine resources being impacted by oil at a thickness greater than 10g/ m², hence containment and recovery will be considered for this scenario. Depending on metocean conditions, containment and recovery is expected to have a removal efficiency of 10% to 15% (ITOPF, 2013).</p>



Response strategy	Feasible	Benefits
Mechanical dispersion	Possible	Mechanical dispersion assists with the natural dispersion process, encouraging the slick to mix and suspend within the water column where the smaller droplet size enhances the natural biodegradation process. Mechanical dispersion may also be used to assist the chemical dispersion process when sea conditions are calm. Mechanical dispersion is used when surface oil presents a greater risk to the marine environment than entrained oil.
Protection and deflection	Yes	Protection and deflection (use of booms) can be used to protect sensitive receptors by creating physical barriers on the water surface. Corraling is generally effective on persistent oils such as Wandoo Crude. The effectiveness of protection and deflection depends on the thickness of the oil and metocean conditions. Protection and deflection is likely to be used in cases where shoreline contact by visible floating oil is predicted. Protection booms will be deployed if monitoring identifies that visible oil is approaching sensitive receptors and if the assessment shows that the use of booms will result in a net environmental benefit (as assessed through the spill impact mitigation assessment (SIMA)).
Shoreline clean-up	Yes	The OSTM predicts that stranding on shorelines will occur with this magnitude of spill. Consequently, shoreline clean-up is likely to be used as one of the response strategies. Shoreline clean-up is an intrusive response that requires careful site-specific planning in order to reduce secondary impacts such as beach erosion and the spreading oil beyond shorelines. Flushing may be considered if the oil enters high priority/slow recovery habitats such as mangroves. Natural dispersion will occur as the oil is remobilised from rock shelves and hard substrates, while any residual oil will biodegrade. However, shoreline clean-up techniques will only be applied if the assessment shows that they will result in net environmental benefit (as assessed through the SIMA).
Oiled wildlife response	Possible	This is applicable for marine fauna that come into contact with the spill and become oiled. Oiled wildlife response can minimise environmental impacts by: reducing the oiling of wildlife by preventing animals entering the impacted environment; and if practical, the initiation of pre-emptive capture and removal of animals at risk. If animals are oiled prompt initialisation of oiled wildlife response provides a means for rehabilitation and release or humane euthanasia to minimise suffering.

6.2.7 Risk Ranking

6.2.7.1 Consequence

The potential impacts associated with a crude oil release from a well without the use of oil spill response strategies such as chemical dispersion, are provided in Table 6-3.

Whilst none of the individual impacts detailed in Table 6-3 are ranked above Major (4) the cumulative impacts has been assessed as having Catastrophic (5) potential.

6.2.7.2 Well release frequency and likelihood

The likelihood of a production blowout for Wandoo facilities has been reviewed and assessed as 6.33E-05 (Wandoo Safety Case Quantitative Risk Assessment: Wandoo QRA WNB-1000-RH-0011) which is a rare likelihood as per the VOGA risk matrix.

The full scale of this hazard is highly unlikely due to:

- The sub-hydrostatic nature of the reservoir – the characteristics of which are well understood as a result of the history of production operations in the Permit Area. For most Wandoo production wells to flow, the hydrostatic head must be almost completely displaced and replaced with hydrocarbon liquid or gas. A highly unlikely series of technological, procedural, behavioural and monitoring failures at the wellhead and on the platform would be required before this could occur;
- Production wells which have been recently constructed have a limited operating life span where the conditions would allow for the well to naturally flow. Typically, the new well bore will be in operation for 1 to 6-month period where it can naturally flow. In a production scenario for the full scale of the event to occur a full-bore rupture along with a failure of the SSSV would need to occur. During well intervention when the SSSV is locked open the well is depressurised to limit flow potential requiring an unlikely series of technological, procedural, behavioural and monitoring failures for the full scale of this event to occur; and
- VOGA has not considered flow restrictions that would reduce the scale of the event such as intervention equipment, partially closed isolation valves or partially operational well control equipment.

6.2.7.3 Residual Risk Ranking

Based on Vermilion risk matrix and criteria (see Table 5-1), utilising the consequence (5, catastrophic) and Likelihood (A, Rare) of this event, the residual risk level for this environmental hazard is assessed to be Medium (RRII).

6.2.8 ALARP demonstration

6.2.8.1 Overview

The risk associated with a release of hydrocarbon from wells is inherent to the operation and maintenance of a petroleum facility however these risks can be managed through the implementation of effective control measures and associated performance monitoring.

The ALARP assessment has concluded that the risks are being managed to ALARP because:

- There are sufficient layers of protection in place for the current risk level; and
- Additional controls and alternative arrangements were not considered to be practical due to the associated increase to other risks.

6.2.8.2 Existing controls

The hazard summary in Section 6.2 describes the controls for this hazard. The range of controls includes multiple independent layers of protection, including:

Design specification;

- The WNA and WNB structure and wells are covered under the Asset Integrity Management System to ensure that the assets are fit for service. The asset integrity system monitors conditions of the asset and, coupled with asset life extension processes, ensure that there is an understanding of the status of the asset to minimise the likelihood of hydrocarbon release to the environment from structural collapse or loss of well integrity;
- The wells on WNA and WNB are located below the level of the crane and protected by a deck plate from dropped objects. When the deck plates are removed and well control equipment is being installed, the wells will be shut-in, thus limiting the size of potential release.

The likelihood of the loss of well control spill occurring during well intervention is highly unlikely due to:

- the sub-hydrostatic nature of the reservoir requires the well to be almost completely displaced to crude for it to flow;
- the characteristics of the reservoir are very well understood because of the production history of the field;
- Well control equipment (e.g. BOP) to prevent a loss of well control during well interventions;
- Performance monitoring during well interventions confirms control measures are implemented and effective. Deviations from the performance standards are reviewed and risk assessed (using VOGA Deviation Risk Assessment Approval Process) to ensure that the risk levels are tolerable and suitable interim measures are implemented to manage risks to ALARP;
- When required, well operations will be carried out while maintaining continuous overbalance on the well. This overbalance, along with the well control equipment and listed management controls, will ensure redundancy of barriers as well as mitigate against the risk of loss of well control; and
- Even in the extremely unlikely event of a loss of overbalance during operations, the well intervention crew would have to not comply with the management controls for a substantial period of time before an influx large enough to cause the well to flow could occur. This would be required, along with the total failure of barrier equipment (e.g. BOP), before complete well control would be lost. As such, there is only a very remote possibility that oil could flow uncontrolled to surface and in to the environment.

6.2.8.3 Source control

The management of resources, information and communications via the implementation of established procedures is absolutely essential for effective emergency response in order to ensure protection of life, property and the environment.

The VOGA Source Control Contingency Plan [WNB-3000-PD-0007] provides a guideline to the required response and event hierarchy to a well control event, either contained or uncontained and the processes that shall be followed in the event of a well control incident during well construction and/or intervention operations in the Wandoo Field. The acceptability of the VOGA Source Control Contingency Plan has been demonstrated in the Wandoo Well Operations Management Plan [VOG-1000-YG-0006] which has been accepted by NOPSEMA.

The VOGA Source Control Contingency Plan identifies that if a loss of well control cannot be controlled via secondary well control procedures (e.g. closing a BOP), well fluids may continue to be released until a relief well is drilled or the well is capped at the surface and the flow stopped.

The relief well will intersect the uncontrolled zones from the primary well and specialised plugging fluids will be pumped into the well to overcome the reservoir pressure. Well kill modelling will be conducted to confirm the fluid rates, pump rates and volumes that will be required to maintain integrity of the primary bore.

The process associated with planning and drilling of a relief well if required is estimated to take approximately 78 days.

To assess whether this source control option results in the risks and impacts being managed to ALARP, the plan was subject to an evaluation to determine if more could be done sooner and identify what the environmental benefit and associated cost would be.

Based on an assumption that the relief well drilling operation itself could not be undertaken any faster, the critical path stage for the relief well plan was identified to be regulatory approvals. To reduce this time, a dedicated rig, suitable for drilling a relief well with an approved Safety Case would need to be available on standby.

Based on the estimated rig and support costs (~\$1,000,000 day-rate), this would result in an additional ongoing operational overhead for the Wandoo Facility which would make the asset uneconomical. Given the costs associated with having a rig on standby, this option has not been adopted.

Improvement to standby documentation to potentially reduce the time for regulatory approvals has been implemented. Relief well activities are covered in the Well Construction Environment Plan and a MODU Safety Case Revision template will be developed prior to heavy well intervention (HWI) operations on wells capable of sustaining natural flow.

Currently this timeline has been assessed as ALARP based on the current controls in place, however VOGA is actively working with industry to evaluate measures to improve on the ALARP response time model through the APPEA DISC Source Control Response Industry (SCRI) Working Group. The SCRI working group is an APPEA DISC initiative which has been established to drive collaboration and continuous improvement in source control emergency response planning. The Working Group will explore and act on opportunities to align and strengthen the titleholders' source control emergency response capability through "mutual aid" initiatives and drive

continuous improvement by implementing fit-for-purpose and effective source control emergency response strategies.

Relief well timing considers the availability of suitable rigs for the Wandoo Field and wells both on the North West Shelf and Southeast Asia, as well as regulatory approvals. VOGA has a high level of confidence that there is relief well rig supply to meet the timelines for relief well drilling during heavy well intervention (HWI) operations on wells capable of sustaining natural flow associated with this Environment Plan.

VOGA ensures that the VOGA Source Control Contingency Plan and resources are reviewed and managed to enable the lowest reasonably practical response duration prior to heavy well intervention, well construction and annually as part of the Oil Spill Capability Review process.



Table 6-6: Source Control resource requirements and ALARP review

Tactic to achieve the objective	Applicability	Resource requirements
<p>Establish initial Technical Support Teams within 96 hours and full teams within 9 days.</p>	<p>The Corporate Command Operations Chief, in conjunction with the Incident Commander and WWCI, will authorize the assembly of the following dedicated technical teams to undertake the well kill and relief well planning and execution activities outlined in the SSCP:</p> <ul style="list-style-type: none"> • Well Control Response Team • Subsurface Team • Relief Well Planning Team 	<p>6 x Technical Support Teams Personnel (Initial – 96 hours) 15 x Technical Support Teams Personnel (Full – 9 days) VOGA has 2 subsurface team members during operations, and a consultant based (in Perth office) offshore drilling team (8-10 ppl) available during intervention programs that would be utilised for a relief well; Current contract with Wild Well Control can provide an initial 2 personnel for the Relief Well Planning Team, and 6 people within one week; VOGA also has the option, with its international offices, to call on additional internal technical support. In addition, VOGA’s Perth office has contracts in place with major Service Companies during intervention programs for specialised personnel to assist.</p>
<p>Relief Well Planning tasks completed prior to spud (within 30 days).</p>	<p>The following key planning tasks are required prior to relief well drilling operations:</p> <ul style="list-style-type: none"> • Identify well kill options • Determine site survey requirements • Review Relief Well Strategy and Basis of Design • Well Kill and Flow Modelling • Well Programs • Internal HSE and Risk assessments/documentation 	<p>Technical Support Teams Personnel (same as above) plus:</p> <ul style="list-style-type: none"> • 2 x Modelling Personnel within 96 hours • 4 x Modelling Personnel within 9 days. • 2 x VOGA HSE Personnel <p>Contract with specialist to mobilise personnel for dynamic well kill and flow modelling.</p>



Tactic to achieve the objective	Applicability	Resource requirements
Undertake Site Survey prior to spud (within 22 days)	Dependant on the type of MODU to be utilised, different levels of site survey may be required. <ul style="list-style-type: none"> • Drilling Contractors require site survey data to establish the sea-bed conditions and stability and shallow gas risk. • The site survey must be designed to identify any sea-bed or near sea-bed obstructions or anomalies 	1 x Site Survey Vessel + Crew Survey contractor (i.e. Fugro or Neptune) would be able to be engaged within the timeframe required.
Regulatory Approvals completed prior to spud (within 50 days)	Following approval documents required to be reviewed and accepted by NOPSEMA prior to relief well drilling: Well Construction Environment Plan Wandoo Facility Safety Case MODU Safety Case (by MODU contractor) WOMP (new one required).	2 x VOGA HSE Personnel (Safety Case and Environment Plan) 2 of the Technical Support Teams Personnel (WOMP)
Drill rig, equipment and logistics onsite and drilling within 50 days Relief Well completed within an additional 27 days once on site.	In the event of a surface blowout necessitating rig and/or platform abandonment, the drilling of a relief well is most likely required in order to dynamically kill the blow out well.	1 x MODU Based on a rig being available in Australian or Southeast Asian waters. <hr/> 2 x Vessels (Workboats) – use of vessels contracted for drilling program <hr/> Equipment MSAs in place with wide range of oil field equipment and service providers as part of drilling program requirements – this includes for Casing and Wellhead (this includes Cameron, Weatherford, Halliburton, Schlumberger, Drillquip).

VERMILION OIL & GAS AUSTRALIA

Title: Wandoo Facility Environment Plan
 Number: WPA-7000-YH-0007
 Revision: 16
 Date: 21 April 2021



Improvements considered	Assessment of option	Adopted/not adopted
Standby MODU for VOGA Drilling	A standby rig is not reasonable given the costs of standby arrangements (effectively doubling the costs of the drilling program) making drilling an unviable activity.	Not adopted
Standby MODU shared across APPEA MOU Titleholders	This option is not considered feasible for a number of Titleholders due to the remote distances in Australia as well as a substantial range of well depths, types, complexities, geologies and geophysical properties across a range of Titleholders	Not adopted
Pre-Drilling Top Holes	This option is not considered feasible due to the uncertainties related to the location and trajectory of the intervention well, which may vary according to the actual conditions at the time the loss of containment event occurs. Additionally, there is only expected to be a minor reduction in timing for this option and it represents additional environmental impacts and costs.	Not Adopted
Use of relief well injection spool	The surface wellheads utilised already include side outlets to enable the connection of more surface pumping resources. These additional resources can deliver greater kill fluid rates to the relief well. As all Wandoo wells covered by this EP can be killed with a single relief well using mud pumping resources available on standard MODUs, the use of the relief well injection spool would not be required.	Not applicable



Improvements considered	Assessment of option	Adopted/not adopted
<p>Maintaining relief well drilling supplies</p>	<p>There is not predicted to be any reduction in relief well timing or spill duration from VOGA maintaining stocks of drilling supplies (mud, casing, cement, etc.)</p> <p>Contingency stocks for the drilling program would be available in addition to supplies from vendors and NWS supplies of other operators.</p> <p>It would be feasible to source some relief well drilling supplies such as casing, but actual composition of the cement and mud required will need to be well specific.</p> <p>Due to the long lead times associated with procuring well construction equipment through manufacturing, it is necessary to design the relief well utilising sufficiently generic equipment such that equipment could either be purchased from vendor’s inventory or procured from other operators within the region utilising similar equipment. VOGA have MSAs in place with most major local oilfield service and equipment providers.</p> <p>The preliminary design work has been carried out on conceptual well trajectories to allow confirmation of basic relief well plans to enable detailed directional work to commence. The preliminary casing design has been conducted to confirm the ability to construct the well utilising readily available “generic” casing grades and sizes while adhering to VOGA’s well construction standards for well integrity.</p>	<p>Not adopted</p>
<p>Investigate the inclusion of relief well activities within Wandoo Facility EP and Safety Case to enable more rapid regulatory approvals.</p>	<p>Improvement to standby documentation to potentially reduce the time for regulatory approvals.</p> <p>Relief well activities are covered in the Well Construction Environment Plan and a MODU Safety Case Revision template will be developed prior to heavy well interventions on wells with ability to flow naturally to surface.</p>	<p>Adopted</p>
<p>Development of a source control specific IAP for the first 96 hours of a response.</p>	<p>Improvement to standby documentation.</p>	<p>Adopted</p>
<p>Process to track available relief well rigs.</p>	<p>On a monthly basis during heavy well intervention operations on wells capable of sustaining natural flow to surface, VOGA tracks and assesses the suitability of available MODUs, plus MODU activities of registered operators and MODUs with approved safety cases.</p>	<p>Adopted</p>

6.2.8.4 *Oil spill response strategy and resources*

Overview

The ALARP assessment of the response strategies are described in the sections to follow. For each strategy the tactics, applicability and required resources (linked to the OPPs within the Wandoo Facility OSCP) have been identified. Alternate tactics and arrangement have also been assessed to ensure that the impacts have been mitigated to ALARP.

The ALARP review for each strategy is documented and continually managed under VOGA Oil Spill Response Capability Review [VOG-7000-RH-0009].

Monitor and evaluate

Monitoring and evaluation of a spill will be initiated in the event of any spill to the marine environment from the time of spill detection. The tactics and resources employed will be commensurate with the size and type of the spill to ensure the objectives of the resource strategy is being achieved and supporting the Incident Action Plan (IAP) decision-making process.

The ALARP review of the proposed response strategy to meet the environmental objective is provided in Table 6-7.



Table 6-7: Monitor and evaluate ALARP review

MONITOR AND EVALUATE		
Response objective	To ensure the most effective response strategies are being applied and environmental impacts of the spill and response strategies are measured.	
Tactic to achieve the objective	Applicability	Resource requirements
Monitoring to be activated from time of spill detection to inform implementation of response strategies.	Observations will inform emergency response planning by providing key information from onsite command to ICT.	N/A
Platform observations commence immediately following the detection of a spill.	Platform visual observations will inform emergency response planning by providing key information from onsite command to ICT.	Wandoo Field OSCP Document 2, Part 5 Oil Pollution Plans Table 3-4 Monitor and evaluate resource requirements
Visual observations from chartered vessel to be mobilised immediately following the detection of a spill.	Vessel visual observations will inform emergency response planning by providing key information from onsite command to ICT.	Wandoo Field OSCP Document 2, Part 5 Oil Pollution Plans Table 3-4 Monitor and evaluate resource requirements
Aerial observations to be initiated within 2 hours of spill being reported (daylight only).	Aerial visual observations will inform emergency response planning by providing key information from onsite command to ICT.	Wandoo Field OSCP Document 2, Part 5 Oil Pollution Plans Table 3-4 Monitor and evaluate resource requirements
Satellite imagery to be initiated within 2 hours of a spill being reported.	High fidelity photographs using different spectrums to identify the trajectory of the oil and ground truth the OSTM.	Wandoo Field OSCP Document 2, Part 5 Oil Pollution Plans Table 3-4 Monitor and evaluate resource requirements



MONITOR AND EVALUATE		
<p>Preliminary OSTM to be requested within 3 hours of a spill been reported. OSTM to continue as required until the termination criteria met.</p>	<p>Activating the OSTM within this timeframe will ensure that additional data is available to help inform the spill response.</p>	<p>Wandoo Field OSCP Document 2, Part 5 Oil Pollution Plans Table 3-4 Monitor and evaluate resource requirements</p>
<p>Satellite tracking buoys to be deployed within 30 minutes of a spill being reported. Tracking buoys data will be monitored and interrogated at least once every 24 hours.</p>	<p>Satellite tracking buoys available in Wandoo field which will help to inform initial trajectory. Deploying the tracking buoys will provide additional data to inform the spill response.</p>	<p>Wandoo Field OSCP Document 2, Part 5 Oil Pollution Plans Table 3-4 Monitor and evaluate resource requirements</p>
<p>Operational monitoring available to inform IAP process prior to implementation of strategies that have an environmental impact (e.g. dispersant application).</p>	<p>A range of surveillance and data collection methods are specified in the OPPs to gather environmental data and inform the 24-hour IAP cycle.</p>	<p>Wandoo Field OSCP Document 2, Part 5 Oil Pollution Plans Table 3-4 Monitor and evaluate resource requirements</p>
<p>Environmental data to support decision making (IAP) and spill impact assessment is available prior to impact.</p>	<p>Baseline data collection is described in the Operational and Scientific Monitoring Plan [WAN-2000-RD-0001.03]. Operational and scientific monitoring plans provide for the minimum resources required for implementation. Resources can be scaled up according to situational need.</p>	<p>Wandoo Field OSCP Document 2, Part 5 Oil Pollution Plans Table 3-4 Monitor and evaluate resource requirements Operational and Scientific Monitoring Plan [WAN-2000-RD-0001.03]</p>
<p>Shoreline Clean-up Assessment Technique (SCAT) teams will complete surveys before clean-up teams complete assignments so that priority locations are identified, and suitable techniques are used.</p>	<p>Resources have been planned for tasks to prevent contact of oil to the protection priorities identified in the Wandoo Field OSCP [WAN-2000-RD-0001]. The estimated number of teams is based on the longest average length of coastline impacted at levels above 100g/m³, with consideration of the day of impact.</p>	<p>Wandoo Field OSCP Document 2, Part 5 Oil Pollution Plans Table 3-4 Monitor and evaluate resource requirements.</p>



MONITOR AND EVALUATE		
<p>Earlier initiation of monitoring activities.</p>	<p>Pre-spill modelling and impact assessment is sufficient to inform initial response planning and resource requirements. OPPs inform the proposed response strategy and equipment items, the information from initial monitoring data helps confirm implementation of response strategies and location of response.</p> <p>This is sufficient time as it would take at least at least six hours to implement the other oil spill response strategies onsite.</p>	<p>Not adopted.</p>
<p>Ongoing real time collection of data prior to any spill event.</p>	<p>Ongoing collection of real time environmental data would provide immediate inputs into decision making however this would require the use of aerial resources, satellite resources, ground surveys and marine surveys.</p> <p>The existing contracts in place for aerial surveillance, satellite imagery, trajectory modelling, marine and shoreline surveys can be activated in a timeframe that provides short, medium, and long-term access to data.</p> <p>An ongoing surveillance program would be at considerable cost to the project. Depending on the measured parameters this could involve ongoing costs in the order of hundreds of thousands each year.</p>	<p>Not adopted.</p>
<p>Surveillance activities conducted during night time hours. E.g. Forward looking infra-red (FLIR) systems can detect oil on water at night.</p>	<p>AMSA Search and Rescue (SAR) aircraft are fitted with side looking airborne radar (SLAR), FLIR, ultraviolet and infra-red marine pollution scanning sensors tuned to detect and map surface oil spills and transmit information back to shore whilst in flight.</p> <p>AMSA SAR aircraft are only available for oil spill response if not tasked for SAR activities. FLIR or SLAR systems are required to be installed on specific aircraft or vessels, not readily available to VOGA. The costs of sourcing such vessels/ aircraft is approximately \$20,000 per day.</p> <p>This has not been adopted in the initial strategy given that there may be the availability of the AMSA SAR aircraft and that daylight observations will enable sufficient response planning. While this would not preclude their use in a spill, VOGA has identified that for the initial response the current arrangements are sufficient to meet the objective, and as such the system is not being planned for.</p>	<p>Not adopted.</p>



MONITOR AND EVALUATE		
UAVs with video or FLIR can detect oil on water or shorelines in remote hard to access areas.	UAVs may provide surveillance in remote areas, and could potential increase the area monitored. However, these were not adopted as it was identified that aerial surveillance proposed in the response would can undertake this task sufficiently.	Not adopted.
Access additional baseline data.	Access to baseline data to inform scientific monitoring programs is required. IGEM (Industry-Government Environmental Meta-database) is a collaboration between the Oil and Gas Industry and Government-funded organisations. Its primary goal is to enable the sharing of marine-based studies between government, industry and other stakeholders in a meta-database format. It provides members the ability to enter, view and filter metadata and export results to a report. Currently IGEM covers the marine environment between the Abrolhos Islands and the Timor Sea, out to the Australia's EEZ (Exclusive Economic Zone).	Adopted - VOGA has joined the IGEM collaboration.
Increase the number of SCAT teams.	The number of SCAT teams proposed is based on the UK SCAT Manual which states responders should plan for three specialists per team, and an estimate of the ability for each time to cover 10km per day. The longest average of shoreline contacted has been predicted at 376 km, which would require 35 teams. Resourcing would include members of state response team, AMOSC core group, industry MOU, etc.	Not adopted.
Provision of additional response personnel.	Expanding mutual aid to include operational and scientific monitoring personnel.	Adopted - VOGA is working with industry partners to review options.
Conclusion	Achieving the environmental objective provides sufficient ability to ascertain extent of spill and assess effectiveness of response strategies.	

Dispersant application

For some of the spill categories, the oil spill response at sea may require the application of dispersant as a key response strategy.

To assess the efficacy of dispersants, VOGA has undertaken efficacy testing, oil spill literature reviews as well as OSTM to assess whether dispersant application provides any potential reduction in impacts from an oil spill. The effectiveness of chemical dispersant application is outlined in the Wandoo Field OSCP [WAN-2000-RD-0001] and the impacts of application of chemical dispersant versus the impacts of non-application of dispersant are assessed in Table 6-31, Table 6-32 and Table 6-33.

Chemical dispersant will only be applied when the IAP decision-making process has determined that its application will have a net environmental benefit. Once the decision to apply chemical dispersant has been supported by the Net Environmental Benefit Analysis (SIMA) process, VOGA will mount an ongoing aerial and marine operation to apply chemical dispersant within the dispersant application zone to allow maximum time for dispersal, thereby reducing the likelihood of shoreline impacts. The Dispersant Application Zone in place (Figure 6-6) is based on criteria that exclude dispersant being applied in the vicinity of submerged sensitive receptors.

Given the environmental sensitivities within the EMBA, the use of dispersants as an offshore response strategy will likely minimise impacts on the ecosystems and reduce the need for extensive shoreline clean-up and remediation. A negative impact is likely on the local offshore fisheries of the region, but its significance will largely depend on the extent and duration of a spill.

The ALARP review of the proposed response strategy to meet the response objective is provided in Table 6-8.



Table 6-8: Chemical dispersant ALARP review

CHEMICAL DISPERSANT		
Response objective	Increase the rate of biodegradation to reduce the environmental impact from surface oil and oil stranding on shoreline sensitivities.	
Tactic to achieve the objective	Applicability	Resources requirements
Dispersant application (aerial and marine) is available to be deployed when Wandoo Crude is most amenable to dispersant for the most effective results.	Analysis has demonstrated that by using the most effective activation timeframes for dispersant stocks, VOGA can obtain dispersant stocks for our needs and arrangements are logistically achievable. Laboratory tests demonstrate that most dispersants are suitable to use within the first 4-5 days of Wandoo Crude being released. As the oil degrades, dispersant effectiveness is reduced.	Section 6.5.3.3.
Aerial dispersant will be available to be applied within 30 hours.	Aerial application of dispersant has been identified as the most effective means to reduce the volume of oil to shorelines, and minimise the impacts of a spill.	Wandoo Field OSCP Document 2, Part 5 Oil Pollution Plans Table 3-6 Chemical dispersant minimum requirements aerial operations
Establish an aerial operating base within 24 hours.	Required to support refuelling and dispersant loading facilities.	Wandoo Field OSCP Document 2, Part 5 Oil Pollution Plans Table 3-6 Chemical dispersant minimum requirements aerial operations
Marine dispersant will be available to be applied within 24 hours.	Marine dispersant will apply dispersant to the leading edge of the oil within the dispersant application zone whilst aerial assets and additional dispersant is mobilised.	Wandoo Field OSCP Document 2, Part 5 Oil Pollution Plans Table 3-8 Chemical dispersant minimum requirements marine operations
Establish a marine operating base within 24 hours.	Required to accommodate vessel and vessel crews at a location close to the response site.	Wandoo Field OSCP Document 2, Part 5 Oil Pollution Plans Table 3-8 Chemical dispersant minimum requirements marine operations



CHEMICAL DISPERSANT		
Use of the most effective chemical dispersant to treat Wandoo Crude.	<p>Laboratory work regarding the window of opportunity and efficacy of dispersants available on weathered Wandoo Crude was undertaken along with detailed testing of the efficacy of dispersants for Wandoo Crude to identify best performing dispersant.</p> <p>ChemCentre conducted study into Wandoo Crude in the Mackay Chamber and found all dispersants in the resource list to be effective on Wandoo Crude.</p> <p>Dispersion modelling conducted to assess the potential change in shoreline contact associated with dispersant use.</p>	Section 6.5.3.3.
Sufficient dispersant stocks available to meet first response demands.	<p>Aerial dispersant - 12m³ per day of dispersant can be applied within 30 hrs and a total of 60m³ for first 2 days then up to 77m³ per day from day 3. For marine operations, approximately 10m³ per day per vessel is required, commencing with one vessel within 24 hours . Sufficient stocks to meet this demand are available via AMOSC, AMSA and OSRL stocks, including 20m³ of Slickgone in AMSA stocks in Dampier as first response.</p>	Wandoo Field OSCP Document 2, Part 5 Oil Pollution Plans



CHEMICAL DISPERSANT		
Improvements considered	Assessment of option	Adopted / Not adopted
Dispersant stockpile availability for the duration of a worst-case spill.	Vermilion conducted a full supply chain and consumption analysis to assess whether there were shortfalls in supply. Review identified membership to OSRL GDS Stockpile was required and changes in supply chain were required to ensure sufficient supply was available at Dampier.	Adopted - implemented additional stockpile in October 2015 and revised logistics strategy in May 2016 to provide sufficient supply during a response. Full assessment detailed within the Oil Spill Response Capability Review [VOG-7000-RH-0009].
Reduce time to application of marine dispersant.	<p>Vermilion has reviewed timeliness of dispersant application to understand benefits (is there reduction in impact) of earlier application and options to improve arrangements to enable a more rapid response.</p> <p>Vessel dispersant capability within 24 hours is currently available to VOGA in Dampier via the existing supply vessel (including a dedicated dispersant spray system and competent personnel) and a longer term arrangement with a first strike oil spill contractor based in Dampier, independent of the supply vessel contract, is feasible and currently being implemented..</p> <p>A loss of well control event would not commence flowing oil for 10 days after the event so a reduced application time is not applicable for a Category E event.</p> <p>For an oil tanker cell spill (Category D) and CGS spill (Category F) scenarios, analysis of the modelling outputs showed that a need for dispersant to be applied within 30 hours is possible in the winter season due to their instantaneous nature, however this was highly unlikely.</p> <p>Due to the size of the instantaneous release of Category D and F, it was assessed that mitigation measure that was accessible within the first 24hrs to reduce spill impact was required, regardless of the remote likelihood of event.</p>	<p>Adopted – vessel dispersant capability within 24 hours is currently available via the existing supply vessel arrangement and includes a dedicated spray system and competent personnel. OPEP has been revised and VOGA Emergency Response Logistics Management Plan [VOG-7000-RH-0008] will be updated to align with this enhancement.</p> <p>This is considered an interim arrangement that is in available to Vermilion based on our current supply vessel contract only, which expires in May 2022.</p> <p>Vermilion will seek to establish an arrangement with a first strike oil spill contractor based in Dampier, independent of the supply vessel contract. The capability for this arrangement (including a dedicated dispersant spray system and competent personnel) will need to be available prior</p>

VERMILION OIL & GAS AUSTRALIA

Title: Wandoo Facility Environment Plan
 Number: WPA-7000-YH-0007
 Revision: 16
 Date: 21 April 2021



CHEMICAL DISPERSANT		
		to the current supply vessel contract expiration, and with targeted implementation of Q1 2022.
Reduce time to application of aerial dispersant	<p>Reducing the application time for aerial dispersant would require either having equipment including FWADC to be located closer to the Wandoo Field, or available on standby. The FWADC are contracted via MOU's and given the requirements under the MOU need to remain at their point of origin, these specific aircraft could not be moved to Karratha and placed on standby. Consequently, additional aircraft would need to be contracted and the spray system adjusted to spray dispersant at the desired droplet size.</p> <p>Having a FWADC would introduce an ongoing cost to the operations of \$30,000/day, or millions of dollars annually (either on hire or purchased craft which would require upkeep). This is not considered to be commensurate to the likelihood of any benefits gained by reducing the timeframe for aerial application to within 24 hours.</p> <p>In lieu of contracting additional aircraft, a more rapid vessel dispersant capability could be used to achieve dispersant application prior to 24 hours.</p>	Not adopted as Vessel based dispersant provides some form of mitigation within 24hrs.
Additional application rates (e.g. more aircraft, vessels, associated equipment).	<p>Review of potential oil surface area that could be dispersed was conducted and it was identified sufficient dispersant could be applied to reduce impact of surface oil from 30 hours post spill (via aerial) and within 24 hours (via marine vessel dispersant capability).</p> <p>The resources have been identified to meet the minimum application rates. If there are spare capacity resources these will be allocated to best mitigate environmental impact from surface oil. Any oil between the application zone and the no-go zone dispersant application will be assessed on what gives us the biggest impact reduction.</p> <p>Additional FWADC would cost approximately \$30,000/day. While this would not preclude the use in a spill, VOGA has identified that for the initial response the current arrangements are sufficient to meet the objective, and as such the additional aircraft is not being planned for.</p>	Not adopted.
Subsea dispersant application.	Subsea dispersant application – considered as not applicable for the Wandoo facility given the surface wells.	Not adopted.



CHEMICAL DISPERSANT		
Increase storage of dispersant in Dampier.	<p>Analysis of the supply chain determined that increasing stockpile in Dampier is not a benefit as current arrangements enable for aerial dispersant to be applied within 30 hours, and marine dispersant within 24 hours.</p> <p>Dispersant can deteriorate over time and effectiveness diminish. For ongoing maintenance, it is more advantageous for industry to store dispersant in larger stockpiles and cooler areas.</p>	Not adopted.
Karratha Airport Joint Standard Operating Procedure (JSOP); and AMSA-AMOSC FWADC JSOP.	<p>Review of dispersant logistics identified that operations plan for dispersant loading and aircraft movement at Karratha Airport was required to ensure activity could be conducted as per plan.</p> <p>Following discussion with Karratha Airport management Draft JSOP has been tentatively agreed with Karratha Airport.</p> <p>AMSA-AMOSC FWADC JSOP details operational details for application of dispersant using the FWADC. A draft JSOP has been completed ready for use when required.</p>	Adopted
Conclusion	<p>The response objective can be achieved as planned resources provide sufficient ability to apply dispersant and prevent released oil impacting shorelines/sensitive receptors and reduce the impact of oil spills.</p> <p>Reviewed improvements to timeframe, application rate and logistics. Identified and implemented two enhancements which supports meeting the objective of this strategy.</p>	

Mechanical dispersion

The impacts associated with this response strategy have been assessed within the scope of the day-to-day operational support activities (such as logistics), or are no greater than the impact of the spill itself.

The ALARP review of the proposed response strategy to meet the response objective is provided in Table 6-9.

Table 6-9: Mechanical dispersion ALARP review

MECHANICAL DISPERSION		
Response objective	Assist natural dispersion of oil into the water column to reduce environmental impact from surface oil.	
Tactic to achieve the objective	Applicability	Resources requirements
Mechanical dispersion is a secondary strategy that will be used opportunistically based on IAP outcomes.	May assist in the physical dispersion of oil into the water column, increasing the speed with which weathering and biodegradation occurs. The Planning Chief will recommend this strategy be implemented based on information collected through monitoring and evaluation.	This will be done on an opportunistic basis when marine resources are available tasked with complementary activities.
Improvements considered	Assessment of option	Adopted / Not adopted
Dedicated vessels.	Mechanical dispersion is not a planned activity, but will be opportunistic as directed by the Planning Chief. A specific level of provision of resources for this activity has not been provided because the vessels used to undertake mechanical dispersion will be tasked for other activities such as transfer of personnel and equipment or monitor and evaluation. This will be done on an opportunistic basis when marine resources are available tasked with complementary activities.	Not adopted.
Conclusion	The objective can be achieved because planned resources provide sufficient ability to physically disperse ad hoc areas of floating oil.	

Containment and recovery

Priority of the implementation of tasks to support this strategy will be focused on containing and recovering oil that has not been successfully chemically dispersed, and to remove as much oil as feasible from the marine environment to prevent it from potentially impacting priority shorelines.

The ALARP review of the proposed response strategy to meet the objective is provided in Table 6-10.



Table 6-10: Containment and recovery ALARP review

CONTAINMENT AND RECOVERY		
Response objective	Reduce overall volume of surface oil to minimise impacts to environmental sensitivities.	
Tactic to achieve the objective	Applicability	Resource requirements
Containment and recovery resources to be mobilised within 72 hours if the data collected through monitoring and evaluation suggests: <ul style="list-style-type: none"> the slick is moving toward a sensitive receptor and unable or unsuitable to be dispersed; sea state and weather conditions allow effective boom and skimmer deployment; the weathered oil is able to be recovered with skimmers; and a safe operating environment for responders. 	Booms and skimmers identified in equipment stockpiles are able to be deployed to priority locations within the timeframe required. Identified ro-boom and skimmers are available locally through AMOSC, AMSA and Australian Marine Service Pty Ltd (via stand-by contract). Protection priorities have been identified in pre-spill modelling.	Wandoo Field OSCP Document 2, Part 5 Oil Pollution Plans Table 3-10 Containment and recovery minimum resource requirements
Equipment available for containment and recovery will be suitable for the hydrocarbon type, and access to equipment will be maintained.	Laboratory data indicates that 52% of the Wandoo Crude is likely to be persistent hydrocarbons meaning that there will be visible surface oil to target with containment and recovery activities. The ro-boom that is identified in the Wandoo Field OSCP is suitable for offshore containment as described in the National Plan OHS Manual. The AMSA contingency planning guidelines were used to inform boom encounter rate calculations and the minimum thickness of oil considered viable to contain and recover was 10g/m ² . Offshore boom is characterised by a higher freeboard and longer skirt than nearshore boom types allowing for deployment in conditions with greater wave movement than sheltered nearshore environments (Fingas 2013).	Wandoo Field OSCP Document 2, Part 5 Oil Pollution Plans Table 3-10 Containment and recovery minimum resource requirements



CONTAINMENT AND RECOVERY		
	<p>The active weir and brush skimmer recovery systems (i.e. GT185 skimmer or Desmi 250) that is identified in the Wandoo Field OSCP is suitable for offshore containment as described in the National Plan OHS Manual.</p> <p>VOGA used the assumption that only a 50% recovery rate would be achieved (20 tonne per hour skimming). This was to allow for the potential waves, wind and oil viscosity that may made recovery less effective.</p>	
Waste storage and transport plan will be developed within 72 hours of the spill event.	Given that there is sufficient time before the waste is being generated, a plan will be in place prior to the waste needing to be unloaded from this response strategy.	Wandoo Field OSCP Document 2, Part 5 Oil Pollution Plans Table 3-10 Containment and recovery minimum resource requirements
Temporary waste storage equipment and arrangements will be maintained.	Maintain access to waste transport equipment, personnel, transport and disposal facilities (liquid and bulk).	Wandoo Field OSCP Document 2, Part 5 Oil Pollution Plans Table 3-10 Containment and recovery minimum resource requirements

VERMILION OIL & GAS AUSTRALIA

Title: Wandoo Facility Environment Plan
 Number: WPA-7000-YH-0007
 Revision: 16
 Date: 21 April 2021



Improvements considered	Assessment of option	Adopted / Not adopted
<p>Implement a greater containment and recovery response (i.e. increase the number of teams).</p>	<p>Each additional team comprising additional vessels, equipment and personnel could potentially recover an additional 80m³ of floating oil per day.</p> <p>However, containment and recovery operations cannot operate simultaneously in the same area where targeted aerial dispersant application is being undertaken. Utilising additional containment and recovery teams at sea may start to impede dispersant application which is considered to provide a more effective response technique (in achieving the objectives, planning to implement additional containment and recovery teams may start to reduce the effectiveness of the response and thus is not expected to provide significant benefit).</p>	<p>Not adopted.</p>
<p>Deploy containment and recovery resources sooner</p>	<p>Currently capability is based upon response implementation within 72 hours of spill incident.</p> <p>Access to offshore vessels is the critical component associated with a containment and recovery response as other equipment is able to be mobilised to Dampier within a day. The ability to implement a response sooner than 72 hours would require immediate access to vessels. To ensure that a single vessel is available would require the vessel to be contracted at a cost in the order of \$20,000/day. On the basis that a single team is on standby (two vessels) costs are upwards of \$40,000, and on the assumption that a single team would realistically recovery 80m³ of oil per day. Given the small volume of hydrocarbons recovered and subsequent incidental environmental benefit, the costs are considered significant for the environmental benefit gained.</p>	<p>Not adopted.</p>
<p>NOFI current buster to complement boom and skimmer operations.</p>	<p>NOFI current buster contains and recovers oil in one system thus providing efficiencies in containment and recovery operations and a subsequent environmental benefit.</p>	<p>Adopted - added to the Wandoo Field OSCP [WAN-2000-RD-0001] for containment and recovery operations.</p>

VERMILION OIL & GAS AUSTRALIA

Title: Wandoo Facility Environment Plan
 Number: WPA-7000-YH-0007
 Revision: 16
 Date: 21 April 2021



Improvements considered	Assessment of option	Adopted / Not adopted
Additional stockpile in Dampier through AMS contract.	Access to additional equipment for containment and recovery activities.	Adopted - added to oil spill response contracts on standby.
Reduce manufacturing time of boom.	<p>Purchase of boom was assessed as not reasonably practicable due to cost and impact reduction.</p> <p>For prolonged events VOGA investigated how much boom is stored in manufacturers warehouses, time required to manufacture booms and what it would take to reduce manufacturing times.</p> <p>Boom manufacturers stock minimum supplies of boom and manufacture it on demand.</p> <p>Manufacturers were also not interested in buying and storing material that would reduce manufacturing time.</p>	Not adopted.
Conclusion	<p>The influence this strategy has on the overall impact reduction of oil is minimal when compared to chemical dispersant. Depending on metocean conditions, containment and recovery is expected to have a removal rate of 10% to 15% (ITOPF, 2013). This is a localised strategy and resources will be allocated based on IAP priorities.</p> <p>With the addition of resources above, planned containment and recovery resources are sufficient to achieve the response objective.</p> <p>The benefit of additional containment and recovery resources to increase oil recovery is outweighed by the operational window, reliability of the system, potential impact reduction and investment required.</p>	

Protection and deflection

Protection and deflection is subject to amenable weather and sea conditions as well as equipment operational limits. As for containment and recovery, the priority of the implementation of tasks to support this strategy will be focused on deflecting oil that has not been successfully chemically dispersed and nearing shorelines.

The ALARP review of the proposed response strategy to meet the response objective is provided in Table 6-11.



Table 6-11: Protection and deflection resource requirements and ALARP review

PROTECTION AND DEFLECTION		
Response objective	Minimise environmental impacts to priority near-shore environmental sensitivities by reducing oil contact.	
Tactic to achieve the objective	Applicability	Resource requirement
Protection and deflection equipment and resources required to be deployed to protection priorities within 48 hours of Category D, E and F spill event.	Land sea boom identified in equipment stockpiles are able to be deployed to staging area within a day for further deployment to priority locations within the timeframe required. Protection priorities have been identified in pre-spill modelling.	Wandoo Field OSCP Document 2, Part 5 Oil Pollution Plans Table 3-14 Protection and deflection minimum resource requirements
Equipment available for protection and deflection will be suitable for the hydrocarbon type, and access to equipment will be maintained.	Booms have been specifically selected for the NWS environmental conditions. Limitations of booming systems with regard to tides and currents is understood. The selection of nearshore boom systems and vessels is appropriate for nearshore and shallow area work.	Wandoo Field OSCP Document 2, Part 5 Oil Pollution Plans Table 3-14 Protection and deflection minimum resource requirements

PROTECTION AND DEFLECTION		
Improvements considered	Assessment of option	Adopted / Not adopted
Reduce deployment time of protection and deflection resources through various means including pre-positioning equipment at protection priorities; or storing on vessels.	Unlike other strategies, this response requires small to medium sized vessels which are more readily available, and thus implementation of this strategy is limited by mobilisation times of protection and deflection equipment. The risk of shoreline contact within 72 hours is unlikely and exact locations of shoreline contact not known until real time modelling is available. There is little environmental benefit in reducing deployment times as existing equipment can be deployed within three days.	Not adopted.



PROTECTION AND DEFLECTION		
<p>Implement a greater initial protection and deflection response.</p>	<p>Oil doesn't contact all shorelines instantaneously, but reaches various locations over a period of time dependant on oceanic currents and wind directions. As such, implementing a greater initial response is not appropriate, however resources are ramped up over a longer period of time as they are required.</p> <p>Mobilising additional resources too early, may result in excess resources being on-location that are not required. Consequently, this has the potential to cause additional environmental impacts if larger than required storage areas and increased personnel presence result in further sensitising coastal habitats without providing significant benefit.</p>	<p>Not adopted.</p>
<p>Tactical plans for identified protection priorities.</p>	<p>Tactical plans can assist response teams identify appropriate protection shoreline response.</p> <p>The development of tactical plans were identified as a priority action to better inform the implementation of response strategies and determine local resource requirements and supply chain mobilisation and staging considerations.</p>	<p>Adopted</p>
<p>Conclusion</p>	<p>The influence this strategy has on the overall impact of a large-scale oil spill is minimal. It is a localised strategy and resources will be allocated based on IAP priorities. Preparation of tactical plans will assist in the implementation of IAP activities.</p> <p>Not all protection priorities will be contacted at the same time, planned resources provide sufficient ability to prevent floating oil contacting shorelines and reducing the impact of oil spills.</p>	

Shoreline clean-up

The purpose of shoreline clean-up is to remove stranded hydrocarbons from shorelines without causing greater environmental damage impact than leaving the hydrocarbons in-situ.

The ALARP review of the proposed response strategy to meet the response objective is provided in Table 6-12.

Shoreline clean-up will implement a three-stage methodology:

- Bulk removal of oil from the shore to prevent remobilisation;
- Removal of stranded oil and oiled shoreline material; and
- Final clean-up of light contamination and removal of stains, if required.

The focus for shoreline response will be initially on areas of heavy oiling where manual collection is possible and there is a moderate to high potential for remobilisation of the oil. Sandy shorelines are generally the most accessible and amenable to manual and mechanical clean-up activities than mangroves, mudflats and salt flats. However, with extensive repeated shoreline clean-up operations, there is a risk these activities can cause their own impacts. That is, each shoreline clean-up operation may cause additional negative ground disturbance.

As a part of response planning, Vermilion has undertaken assurance around the provisioning required to implement large scale shoreline clean up. As such Vermilion has detailed a base case inventory of the human resources and major oil spill response equipment needed to implement a shoreline clean-up response based on a worse-case deterministic modelling run for a theoretical oil spill. Based on the modelling output, the length of each major shoreline type that might be contacted and the volume of oil ashore was estimated and volume. Personnel resources needed to clean-up the oiled shoreline was then determined.



Table 6-12: Shoreline clean-up ALARP review

SHORELINE CLEAN-UP		
Response objective	Remove stranded hydrocarbons from shorelines without causing greater environmental impact than leaving the hydrocarbons in-situ.	
Tactic to achieve the objective	Applicability	Resource requirements
Equipment for shoreline clean-up tasks that are suitable for environment and hydrocarbon type are available.	<p>Resources have been planned for tasks to prevent contact of oil to the protection priorities identified in the Wandoo Field OSCP [WAN-2000-RD-0001].</p> <p>Resources include:</p> <ul style="list-style-type: none"> Logistics – crew being accommodated, safe and in contact with other parts of the response. Vessels – capable of carrying crew and spill equipment to remote islands. Equipment – cleaning equipment, decontamination set, mechanical equipment, etc. Booming systems – a system that can effectively direct or prevent the movement of oil. 	<p>Wandoo Field OSCP Document 2, Part 5 Oil Pollution Plans</p> <p>Table 3-16 Shoreline clean-up minimum resource requirements</p>
Shoreline clean-up resources can be deployed to protection priorities within 72 hours.	Maintaining access to shoreline clean-up resources including equipment and personnel will enable deployment to protection priorities within a timeframe.	<p>Wandoo Field OSCP Document 2, Part 5 Oil Pollution Plans</p> <p>Table 3-16 Shoreline clean-up minimum resource requirements</p>



SHORELINE CLEAN-UP		
Manning of shoreline clean-up teams	<p>VOGA has analysed OSTM data to inform shoreline clean-up personnel requirements as described in the Wandoo Field OSCP.</p> <p>Shoreline clean-up teams will scale up from 3 teams (one leader and ten workers) in the first three days to up to 100 teams by day 20. For planning purposes, VOGA utilises the IPIECA (2015) Shoreline clean-up guidelines which suggest that one person can remove 1m³ of oil per day from a shoreline using clean up techniques described in Wandoo Field OSCP Document 1, Table 7-8.</p>	<p>Wandoo Field OSCP Document 1, Part 2 Response Strategies Table 7-11 Shoreline clean-up potential waste and personnel requirements</p> <p>Wandoo Field OSCP Document 2, Part 5 Oil Pollution Plans Table 3-16 Shoreline clean-up minimum resource requirements</p>
Shoreline teams will be informed of how to minimise damage to flora and avoid encounters with fauna.	Trainers will provide guidance to shoreline teams to minimise impacts to the environment while undertaking assessment and clean-up activities.	<p>Wandoo Field OSCP Document 2, Part 5 Oil Pollution Plans Table 3-16 Shoreline clean-up minimum resource requirements</p>
SCAT teams will complete surveys before clean-up teams complete assignments so that priority locations are worked on and suitable techniques are used.	<p>SCAT teams will assess shorelines for oiling and sensitivity prior to operations commencing.</p> <p>Available and suitable shoreline clean-up resources are deployed if there are sufficient quantities of oil to be collected, areas predicted to be impacted have a long recovery time, and impact reduction is not outweighed by impact of activity.</p>	Refer to Table 6-7.

VERMILION OIL & GAS AUSTRALIA

Title: Wandoo Facility Environment Plan
 Number: WPA-7000-YH-0007
 Revision: 16
 Date: 21 April 2021



SHORELINE CLEAN-UP		
<p>Shoreline clean-up will implement a three-stage methodology: Emergency phase – collection of oil floating close to the shore Project phase – removal of stranded oil and oiled shoreline material that cannot be cleaned in-situ. Polishing phase – final clean-up of light oil contamination and removal of oil stains, SIMA dependent</p>	<p>Actual clean-up tasks for each of the three stages will be selected from the most appropriate activities, based on an assessment of suitability for the clean-up task for the oil character and shoreline type, and will be dependent on the data collected by the SCAT teams.</p> <p>In undertaking this three-step process, VOGA contractors, employees and support agencies will work to effectively and efficiently clean shorelines where possible.</p>	<p>Wandoo Field OSCP Document 2, Part 5 Oil Pollution Plans Table 3-16 Shoreline clean-up minimum resource requirements</p>
<p>Waste storage and transport plan will be developed within 72 hours of the spill event.</p>	<p>Solid contaminated waste estimated volumes based on a bulking factor of 10, as per IPIECA (2015)</p>	<p>Wandoo Field OSCP Document 2, Part 5 Oil Pollution Plans Table 3-16 Shoreline clean-up minimum resource requirements</p>
<p>Temporary waste storage equipment and arrangements will be maintained.</p>	<p>Maintain access to waste transport equipment, personnel, transport and disposal facilities (liquid and bulk).</p>	<p>Wandoo Field OSCP Document 2, Part 5 Oil Pollution Plans Table 3-16 Shoreline clean-up minimum resource requirements</p>



SHORELINE CLEAN-UP		
Improvements considered	Assessment of option	Adopted / Not Adopted
Reduce the time for shoreline response.	<p>Allocating shoreline clean-up resources relies on understanding the trajectory of the oil and timeframe for expected contact. It is not practical to pre-position teams ready for rapid deployment to reduce the timeframe for shoreline response because the stochastic OSTM used in planning indicates a number of potential shoreline contact locations. Resources (people and equipment) can be activated and deployed on initiation of OPP2 in readiness for the real time OSTM outputs.</p> <p>Earliest contact on shorelines is predicted to be Day 3, this is sufficient time to mobilise people and equipment.</p>	Not adopted.
Increase manning of shoreline clean-up teams	VOGA has planned for shoreline clean up teams of 10 (IPIECA, 2015). An assessment of what further work is required can then be made and a decision to increase or decrease personnel made.	Not adopted.
Increase in the number of vessels used to support shoreline response.	Vessels will be used to transport people and equipment; and assist in nearshore protection and deflection if required. The minimum resources specified are sufficient to transport the shoreline clean-up teams to locations identified in planning OSTM. These can be ramped up if required after the initial response activities using VOGA's marine contract lists.	Not adopted.
Increase in the number of equipment sets used to support shoreline response.	The equipment sets identified in planning are intended to be used for manual removal of oil from shorelines. Not all oil on shorelines will be able to be manually removed with this equipment. One set of manual clean-up tools per team is sufficient as a minimum requirement (8 teams = 80 sets). Real time modelling and assessment will determine if extra resources are required. If this is the case, then the clean-up tools required are readily available from hardware outlets and can be transported to site within a day.	Not adopted.



SHORELINE CLEAN-UP		
Preposition containers of equipment.	Equipment stockpiles in Exmouth and Dampier are sufficient to deploy equipment in a timely manner. Equipment can be transported from Perth in a timely manner. VOGA owns shoreline clean-up equipment to mount an initial shoreline response.	Not adopted.
Survey shorelines and describe characteristics pre-spill.	Shoreline surveys are costly and resource intensive. Surveys have been conducted by other operators, coastal compartment mapping available – no benefit in VOGA undertaking more field work but rather compiling existing information regarding protection priorities.	Not adopted - VOGA has joined the IGEM collaboration.
Tactical plans for identified protection priorities.	Tactical plans can assist response teams identify appropriate protection shoreline response. The development of tactical plans were identified as a priority action to better inform the implementation of response strategies and determine local resource requirements and supply chain mobilisation and staging considerations.	Adopted
Conclusion	Not all protection priorities will be contacted at the same time, planned resources provide sufficient ability to remove stranded oil on shorelines where appropriate and reducing the impact of oil spills to ALARP.	

Oiled wildlife response

Capability for an oiled wildlife response has been prepared at an Oiled Wildlife Level 6 response as per the Pilbara Oiled Wildlife Response Plan (POWRP).

Analysis of OSTM data for a worst-case spill scenario was undertaken in conjunction with information on environmental sensitivities to identify the initial protection priorities for wildlife. The output from this analysis is an understanding of the scale of the operating area and timeframe for both the initial response and the scaling up oiled wildlife capabilities.

The focus for VOGA pre-planning of response activities regarding first strike response and initial resource mobilisation is the Pilbara coast and associated offshore islands between Robe River Mouth and Dampier Archipelago. This area is the most likely to be impacted first, contains several sensitive locations and aligns with the Pilbara Oiled Wildlife Response Plan (POWRP) Operational Sectors 7 to 12. Dampier is the site most likely to require an oiled wildlife facility.

For indicative planning for Day 9 and beyond, OSTM analysis indicates that several sensitive locations from Robe River Mouth down to North West Cape and from Dampier up to Eighty Mile Beach may be impacted to varying levels and require wildlife response between Days 9 and 20. Between Days 20 and 30, from Eighty Mile Beach up to Broome is potentially impacted.

This could require staging sites in various locations in addition to holding centres and/or oiled wildlife facilities (small, medium or large) to be set up in Exmouth, Onslow, Port Hedland or Broome in these timeframes. Sites are pre-identified in the POWRP and the most appropriate locations will be determined in a response with real time trajectory data and analysis of seasonal vulnerabilities through the SIMA process and in consultation with DoT. The ALARP review of the proposed response strategy to meet the response objective 'to minimise and mitigate the number of wildlife oiled following a spill' is provided in Table 6 13.



Table 6-13: Oiled wildlife ALARP review

OILED WILDLIFE RESPONSE		
Response objective	Minimise and mitigate the number of wildlife oiled following a spill.	
Tactic to achieve the objective	Applicability	Resource requirement
Resources for oiled wildlife response activities have been planned for a Level 6 Oiled Wildlife Response.	Resources have been planned for a Level 6 Oiled Wildlife Response due to the quantity and location of wildlife potentially contacted by oil. AMOSC and DPaW activate the Western Australian Oiled Wildlife Response Plan (WAOWRP) and POWRP resources and provide specialist oiled wildlife response support.	Wandoo Field OSCP Document 2, Part 5 Oil Pollution Plans Table 4-6 Oiled wildlife response minimum resources
First strike response kits are activated within 24 hours.	Support mobilisation of first strike response kits to priority shoreline staging areas.	Wandoo Field OSCP Document 2, Part 5 Oil Pollution Plans Table 4-6 Oiled wildlife response minimum resources
Two oiled wildlife response containers are mobilised to an oiled wildlife response facility location in Dampier within 24 hours.	Dampier to be set up first to service POWRP Operational Sectors 7 to 12. The response strategies in the initial incident action plan for OWR are to complete Stages 1, 2 and 3 of OWR as described in the WAOWRP: <ul style="list-style-type: none"> • Stage 1 – wildlife first strike response. • Stage 2 – mobilisations of wildlife resources. • Stage 3 – wildlife reconnaissance 	Wandoo Field OSCP Document 2, Part 5 Oil Pollution Plans Table 4-6 Oiled wildlife response minimum resources
An Oiled Wildlife Advisor and Wildlife Division Coordinator are activated and assigned to the ICT once WAOWRP is activated.	Activate and mobilise an Oiled Wildlife Advisor and Wildlife Division Coordinator to Dampier. Source unskilled personnel (oiled wildlife response skill level 1) mobilise to Dampier and conduct induction process and basic training developed by DPaW. Access to DPaW volunteer database to also be undertaken via the DPaW Duty Officer.	Wandoo Field OSCP Document 2, Part 5 Oil Pollution Plans Table 4-6 Oiled wildlife response minimum resources



OILED WILDLIFE RESPONSE		
Information contained in POWRP and SIMA is ground truthed.	Reconnaissance across priority shorelines. Resources are required to identify and record location of oiled wildlife as well as determining the presence of wildlife in areas predicted to be impacted by oil. Real time wildlife reconnaissance is necessary to ground truth information contained in the POWRP due to seasonal and interannual variation in abundance and distribution. Tactics include: <ul style="list-style-type: none"> • Aerial reconnaissance; • Marine reconnaissance; and • Shoreline reconnaissance. 	Wandoo Field OSCP Document 2, Part 5 Oil Pollution Plans Table 4-6 Oiled wildlife response minimum resources
IAP wildlife sub-plan developed within 48 hours.	Future oiled wildlife response activities arrangements developed based on the spill scenario and will be guided by the WAOWRP. The aim of the OWR sub-plan will be to: <ul style="list-style-type: none"> • Reducing the oiling of wildlife by preventing animals from entering the impacted environment; • If animals are oiled, maximise the number of oiled wildlife treated and/or rehabilitated; and • Remove dead and dying wildlife from affected area to minimise secondary exposure. 	Wandoo Field OSCP Document 2, Part 5 Oil Pollution Plans Table 4-6 Oiled wildlife response minimum resources
Wildlife rescue and staging are developed within 72 hours.	Begin establishing staging site as a logistic base for search and capture teams. Staging areas to be set up in most appropriate POWRP Operational Sectors based on the spill trajectory.	Wandoo Field OSCP Document 2, Part 5 Oil Pollution Plans Table 4-6 Oiled wildlife response minimum resources

VERMILION OIL & GAS AUSTRALIA

Title: Wandoo Facility Environment Plan
 Number: WPA-7000-YH-0007
 Revision: 16
 Date: 21 April 2021



OILED WILDLIFE RESPONSE		
Improvements considered	Assessment of option	Adopted / Not Adopted
Pre-positioning of oiled wildlife response resources.	Oiled wildlife response equipment containers for first strike activities are positioned in Exmouth.	Not adopted.
Additional resources (equipment and personnel).	VOGA has undertaken an oiled wildlife assessment to estimate the approximate numbers of wildlife requiring care over time and region. This was assumed without the application of dispersant and so represents a conservative estimate. To meet the increased resource requirement, VOGA invested in oiled wildlife response equipment in 2013. WAOWRP and POWRP planned resources assessed as sufficient for the worst-case spill risk.	Adopted –an oiled wildlife response Level 6 have been adopted for OPP2.
Prepare induction training for oiled wildlife response labour hire personnel.	Prepared induction training allows for personnel to be deployed when required.	Adopted
Conclusion	VOGAs oiled wildlife response capability was undertaken based on the number of wildlife requiring care identified in an oiled wildlife risk assessment. Resources identified in the WAOWRP, POWRP and the Wandoo Field OSCP [WAN-2000-RD-001] were assessed as sufficient to mount an initial oiled wildlife response.	

6.2.8.5 *ICT Systems and resources*

Section 7.10.5.2 describes the process of how VOGA has determine ICT arrangements and ensure it can meet requirements.

Over the last five-years the following improvements to ICT systems and resources have been implemented:

- Improving the Wandoo Field OSCP [WAN-2000-RD-0001] layout to separate the planning and preparedness information and response information;
- Establishing oil pollution plans (OPP1 and OPP2) which are initial action plans to be activated on identification/notification of spill events;
- Spill mitigation and impact assessment (SIMA) tool which utilises environmental impact assessments and oil spill trajectory used in the EP process. Enhancement enables ICT to produce an initial SIMA (based on season and spill type) which accompanies the OPP on activation;
- Developing support plans, such as logistics plans (see section 7.10.6), which is are designed to minimise response times and improve performance;
- Establishing an ICT resource plan in the OPEP which outlines ICT resources required for a full scale response over the first 20 days;
- Oil spill specific response training; and
- Establishing remote access tools to enable

VOGA will continue to review and enhance the ICT arrangements through its annual capability review process (described in Section 7.10.7.2).

6.2.8.6 *Additional controls and alternative arrangements*

VOGA carried out an assessment of alternative arrangements and additional controls to reduce risks. No additional controls were identified.

6.2.8.7 *Conclusion*

The ALARP assessment has concluded that the risks are being managed to ALARP because:

- There are sufficient layers of protection in place for the current risk level;
- In the unlikely event of spill from the wells, response strategies which match the hazard profile are defined in the Wandoo Field OSCP [WAN-2000-RD-0001] and will be implemented to reduce the impact of the spill to the environment. The resources to implement the response has been determined and evaluated to ensure that the response strategies mitigate the spill and can be achieved; and
- As the alternative arrangements are either not considered practical, increase associated safety, do not reduce environmental impact and are not sustainable from a cost or environmental impact point of view.

6.2.9 Acceptability demonstration

Acceptability of the potential impacts for this hazard has been assessed in accordance with VOGAs management systems and as required by the OPGGS(E)R:

- The likelihood of multiple concurrent failures of controls during well intervention operations that could lead to a total loss of well control is remote in the extreme, because of long production history and the sound understanding of the characteristics of the reservoir and its sub-hydrostatic nature;
- Sufficient layers of protection are in place through the application of the VOGA Well Construction Management System, the Contractor's management system and the Well Operations Management Manual to ensure that the controls are in place to maintain well integrity;
- As the alternative arrangements are not considered practical, increase associated safety and environmental risk and/or are not sustainable from a cost or environmental impact point of view;
- Ongoing stakeholder consultation undertaken for this EP did not generate any feedback regarding concerns due to spills from a loss of well control;
- With the preventative and mitigative controls in place, the conservation of biological diversity and ecological integrity shall be maintained;
- Well intervention activities are sometimes required to maintain or reinstate well integrity operations; and
- In the event of a hydrocarbon spill, the activities, and the proposed performance management measures, meet the requirements of internal VOGA procedures that have been developed in accordance with relevant environmental legislation.



6.3 Liquid hydrocarbon release from export equipment, submarine hose, floating hose or export flow lines

6.3.1 Hazard report

Table 6-14: Hazard report – Liquid hydrocarbon release from export equipment submarine hose, floating hose or export flow lines

HAZARD:	Liquid hydrocarbon release from export equipment, submarine hose, floating hose or export flow lines					
EP risk no.:	EP-OP-R02					
CEE:	CEE-02 – Loss of Containment (Offtake Tanker) (Liquid hydrocarbon release from offtake tanker crude oil/HFO storage)					
Potential impacts:	Hydrocarbon release to environment, i.e. 10,000m ³ of crude oil to sea (vessel collision with tanker as worst-case scenario). Tanker fuel spill to sea, i.e. 1300m ³ of HFO to sea. Loss of crude oil from export system, i.e. <300m ³ crude oil to sea.					
PREVENTION:						
Activity/cause:	Existing management controls	Control type	Control hierarchy	Performance outcome	Performance standard	Measurement criteria
Offtake tanker station keeping failure causing hose rupture.	Marine breakaway coupling on FHA.	Engineering	Reduction	Prevent the release of crude oil to the marine environment due to offtake tanker station keeping	Marine breakaway coupling shall be installed on FHA and designed to part prior to failure of FHA to minimise volume of oil spill.	Marine breakaway coupling testing record.
	Hawser is fit for purpose.	Engineering	Reduction		Hawser, chains and shackles shall be checked for mechanical damage and wear prior to offtake, as per the SPM Marine Facility Procedures [WPA-7000-YV-0002].	Offtake Maintenance Report.
	Structural integrity of CALM Buoy mooring.	Administrative	Reduction		Performance criteria, ensuring inspection of CALM buoy mooring as per <ul style="list-style-type: none"> WAN-WNB-CE-PR-07-03. 01 - Mooring System - CALM Buoy, including mooring arm WAN-WNB-CE-PR-07-03. 02 - Mooring System - Chains and Anchors 	Assurance records, as per <ul style="list-style-type: none"> WAN-WNB-CE-PR-07-03. 01 - Mooring System - CALM Buoy, including mooring arm WAN-WNB-CE-PR-07-03. 02 - Mooring System - Chains and Anchors
	Weather restrictions apply to offtake activities.	Administrative	Reduction		Offtake operations shall be restricted in adverse weather, as per the SPM Marine Facility Procedures [WPA-7000-YV-0002].	Offtake Maintenance Report.
					Weather restriction criteria is reviewed based on load cell data to ensure criteria is appropriate. Load cell data monitoring of hawser tension against recorded weather conditions to ensure assumptions are valid.	Annual check of load cell data against recorded weather conditions.
	Wandoo Mooring Master on board tanker during offtake.	Administrative	Reduction		Wandoo Mooring Master meets minimum competency standard as per contract	Training records confirmed for Mooring Master
	Static tow by support vessel to control tanker position	Engineering	Reduction		A support vessel shall be present to assist with each offtake operation and must remain connected to the Tanker, providing static tow, throughout the offtake as per as per the SPM Marine Facility Procedures [WPA-7000-YV-0002].	Safety Checklist



Activity/cause:	Existing management controls	Control type	Control hierarchy	Performance outcome	Performance standard	Measurement criteria
Crude oil spill due to submarine hose, FHA or marine breakaway coupling failure (includes spurious activation and FHA detachment).	Asset integrity management.	Engineering	Reduction	Prevent the release of crude oil to the marine environment due to submarine hose, FHA or marine breakaway coupling failure.	Inspections and testing undertaken on export system, as per Performance criteria, as per WAN-WNAB-CP-PR-04-04 – Integrity Management. The integrity of critical elements is shall be maintained at all times	Assurance records, as per Performance criteria, as per WAN-WNAB-CP-PR-04-04 – Integrity Management.
	Operating within design limits.	Engineering	Reduction		Pre-start checks undertaken, as per the SPM Marine Facilities Procedures [WPA-7000-YV-0002].	Offtake Maintenance Report
	Holdback device on Marine breakaway coupling	Engineering	Reduction		Holdback device installed on Marine breakaway coupling to prevent spurious detachment of FHA	Inspection records
Dropped objects/ swinging load onto export systems.	Lifting management procedures.	Administrative	Reduction	Maintain sufficient integrity so that loads or any lifting component does not fall in such a manner that it may cause, or contribute, to a release of hydrocarbon to the marine environment.	Crane operations shall be managed as per the Crane Operations, Maintenance and Inspection Manual [WPA-7000-YM-0002] to ensure safe lifting operations to prevent dropped objects or swinging loads.	Crane Operator Checklist completed prior to crane operation.
	Crane maintenance.	Engineering	Prevention		Performance criteria, as per WAN-WNAB-CE-PR-05-01 - Platform Cranes and Man-riding Winch shall be maintained to enable safe lifting operations to prevent dropped objects or swinging loads	Assurance records, as per WAN-WNAB-CE-PR-05-01 - Platform Cranes and Man-riding Winch.
Crude oil spill due to anchor drag during project activities	Cautionary zones around the subsea production systems are marked on field navigational charts.	Administrative	Reduction	No leaks from export systems due to anchoring activities by providing information on infrastructure location.	Anchoring location and cautionary zone identified in the Wandoo Marine Operations Manual (vessels) and SPM Marine Facilities Procedures [WPA-7000-YV-0002] (tankers)	Operations log (tankers) Wandoo Marine Operations Manual provided to vessels
Attending or passing vessel collision with tanker whilst on station and connected to the Wandoo asset.	Weather restrictions.	Administrative	Reduction	Prevent the release of hydrocarbons from tanker to the marine environment due to vessel collision.	Offtake operations shall be restricted in adverse weather, as per the SPM Marine Facility Procedures [WPA-7000-YV-0002].	Offtake Maintenance Report.
	Platform location published on Marine Charts.	Administrative	Reduction		Wandoo facilities are marked on marine charts and any changes to Wandoo facilities shall be notified via Notices to Mariners.	Records to confirm that Wandoo facilities are on Marine Charts and applicable Notice to Mariners.
	Tanker navigation aids	Engineering	Reduction		Regulatory compliant tanker navigation aids, as per the SPM Marine Facilities Procedures [WPA-7000-YV-0002].	Safety Checklist.
	Tanker communications in place	Engineering	Reduction		Radio communications in place with production facility and available to support vessel and passing vessels during berthing, loading and unberthing	Safety Checklist
	Emergency communications.	Engineering	Prevention		Performance criteria, as per WAN-WNAB-CE-ES-02-01 – UHF/VHF Radios. To ensure communication between CCR and the Emergency Response Team (at any location on the installations), personnel on WNA, personnel on CALM Buoy and external parties.	Assurance records, as per WAN-WNAB-CE-ES-02-01 – UHF/VHF Radios.
	500m restriction zone surrounding the facility.	Administrative	Reduction		500m restriction zone surrounding the facility, as per the Wandoo Marine Operations Manual [WNB-1000-YV-0001].	Wandoo Marine Operations Checklist.



Activity/cause:	Existing management controls	Control type	Control hierarchy	Performance outcome	Performance standard	Measurement criteria
	Station keeping requirements for vessels.	Administrative	Reduction		Dynamic positioning requirements, as per Section 9 of the Wandoo Marine Operations Manual [WNB-1000-YV-0001].	Wandoo Marine Operations Checklist.
	Vessel operations restricted in adverse weather.	Administrative	Reduction		Vessel operations restricted in adverse weather, as per the Wandoo Marine Operations Manual [WNB-1000-YV-0001].	Wandoo Marine Operations Checklist.
	Static tow by support vessel to control tanker position	Engineering	Reduction		A support vessel shall be present to assist with each offtake operation and must remain connected to the Tanker, providing static tow, throughout the offtake as per as per the SPM Marine Facility Procedures [WPA-7000-YV-0002].	Safety Checklist
	Permission required for field entry, CALM Buoy approach, mooring-up and departure.	Administrative	Reduction		Vessels shall comply with permissioning protocols for vessels entering the field, CALM Buoy approach, mooring-up and departure, as per the Wandoo Marine Operations Manual [WNB-1000-YV-0001].	Wandoo Marine Operations Checklist.

MITIGATION:						
Existing management controls	Control type	Control hierarchy	Performance outcome	Performance standard	Measurement criteria	
Visual monitoring of FHA during offtake.	Administrative	Mitigation	Mitigate the impact of a liquid hydrocarbon release to the marine environment from export equipment, submarine hose, FHA and export flow lines.	Visual monitoring of hose and connections for leaks during loading, including night time operations via torchlight, as per SPM Marine Facilities Procedures [WPA-7000-YV-0002].	Safety Checklist	
Emergency shutdown of crude oil transfer in the event of a leak.	Isolation	Mitigation		Emergency shutdown of crude oil transfer in the event of a leak, as per SPM Marine Facilities Procedures [WPA-7000-YV-0002].	Safety checklist records that emergency shutdown procedures are agreed upon between tanker and production facility	
Wandoo Emergency Response Plan [VOG-2000-RD-0017].	Administrative	Mitigation		The Wandoo Emergency Response Plan [VOG-2000-RD-0017] shall meet the performance criteria as per WAN-WNAB-CP-ER-01 – Emergency preparedness, managements and response	Assurance criteria as per WAN-WNAB-CP-ER-01 - Emergency preparedness, managements and response.	
Oil spill response arrangements	Administrative	Mitigation	To mitigate the environmental impacts as a result of oil spill, by ensuring that measures are in place to mitigate the oil spill hazards associated with activities within the Wandoo Field.	Performance criteria, as per WAN-WNAB-CP-ER-02; WAN-WNAB-CP-ER-03, WNAB-CP-ER-01-05 and WNAB-CP-ER-01-06 (refer to Hazard EP-OP-R01 Table 6-2)	Assurance activities, as per WAN-WNAB-CP-ER-02; WAN-WNAB-CP-ER-03, WNAB-CP-ER-01-05 and WNAB-CP-ER-01-06	

INITIAL RISK WITH EXISTING CONTROLS:		
Consequence	Likelihood (of consequence)	Initial risk
Catastrophic (5)	Rare (A)	Medium



ADDITIONAL CONTROLS/DEMONSTRATION OF ALARP - VOGA WORKSHOP:

A Medium risk is defined as tolerable on demonstration of ALARP under the VOGA risk level action criteria. The following ALARP analysis provides assurance that all risk treatment options have been considered.

Additional management controls	Assessment of option	Adopted/not adopted
Refer to Section 6.2.7 for source control and oil spill response ALARP evaluation tables.		
Standby vessel in situ 24 hrs/day: monitor the PSZ and be equipped with an automatic identification system to aid in its detection at sea, and radar to aid in the detection of approaching third-party vessels.	Reduces risk of vessel collision and subsequent unplanned release of hydrocarbons. High cost associated with contracting standby vessel. Costs of operating navigational equipment. The costs associated with having a vessel on location 24/7 are considered disproportionate to the environmental benefit gained, particularly given the infrastructure are marked on charts and navigational aids are present.	Not adopted
An alternative to exporting via a tanker is a pipeline to shore.	This arrangement is not only cost prohibitive but also could potentially introduce higher spill frequency, and impacts due to the pipeline length, inventory, and proximity to shoreline sensitivities.	Not adopted
Load monitoring system	Load monitoring is utilised for offtakes and included in the SPM Manual however is not considered an independent control as its functions are (1) Gather data for fatigue analysis of the mooring system and (2) as an additional measure to assist the mooring master with information to enable less conservative weather limitations to be applied if offtakes are undertaken without an MBC. As the weather limitations are conservative, the use of the load monitoring system is not required if it is unavailable.	Utilised as a performance standard to support weather criteria

RESIDUAL RISK AFTER ADDITIONAL CONTROLS:

Consequence	Likelihood (of consequence)	Residual risk
Catastrophic (5)	Rare (A)	Medium

ACCEPTABLE LEVEL OF RISK DEMONSTRATED:

Principles of ESD not compromised	External Context – objects or claims considered	Internal Context – VOGA HSE / procedures met	Other Requirements met	RR < High (RRII)	EPO(s) manage risk to acceptable level(s)
Relevant principles of ESD not compromised given proposed controls	N/A – no external objections or claims received	Yes – Risk managed in accordance with VOGA HSE policy and aligned to Performance Standards, Wandoo Marine Operations Manual [WNB-1000-YV-0001] and SPM Marine Facility Procedures [WPA-7000-YV-0002]. Potential spills to be managed in accordance with Wandoo Emergency Response Plan [VOG-2000-RD-0017]/Wandoo Field OSCP [WAN-2000-RD-0001].	Yes – vessels and facility navigation lighting comply with relevant regulations	Yes – RRIII (Medium)	Yes, EPOs specify no uncontrolled release of hydrocarbons. The following relevant overarching EPOs (Section 3.4) maintained providing control measures maintained: EPO-OP-01; EPO-OP-03; EPO-OP-04; EPO-OP-05; EPO-OP-06; EPO-OP-07; EPO-OP-08; EPO-OP-09; EPO-OP-10; EPO-OP-11; EPO-OP-12; EPO-OP-13; EPO-OP-16; EPO-OP-17; EPO-OP-18; EPO-OP-19; EPO-OP-20

6.3.2 Description of hazard

6.3.2.1 Overview

As outlined in Section 2.5.11, crude oil is exported from the Wandoo facilities into an offtake tanker every three to five weeks, typically lasting for 12 to 24 hours depending on the cargo size. The transport of hydrocarbons carries an inherent risk of spills which needs to be managed.

The following three credible crude oil spill hazard scenarios have been identified:

- Loss of crude oil from export system (assumed to be up to 300m³ of Wandoo Crude);
- Breach of an oil tanker cell (assumed to be up to 10,000m³ of Wandoo Crude); and
- Breach of oil tanker's fuel tank (assumed to be up to 1300m³ HFO).

A summary of the oil types used in the Wandoo production is presented in Table 6-15.

Table 6-15: Summary of oil types used in Wandoo activities

Oil type	Oil group	API gravity	Density @ 150C	Pour point (OC)	Flash point (OC)	Viscosity @ 400C	Predicted evaporation	Wax content	Asphaltene content
Diesel Fuel Oil	II	38.8	0.83	-36	40	1.0	High	<1%	<1%
Wandoo Crude (fresh)	IV	19.5	0.9368	-24	144	~48	15%	Low	Low
HFO (from ships)	IV	Varies with specific formulation for ship, generally persistent							

The following sections briefly outline these potential hazardous events and how the controls listed in Section 6.3.1 support the management of the hazards.

6.3.2.2 Loss of crude oil from export system (<300m³ of Wandoo Crude)

Possible causes for a release of hydrocarbon during offloading include:

- Offtake tanker moving during the transfer process (i.e. a station keeping failure) causing the floating offloading hose to rupture;
- A failure of the submarine hose, FHA or marine breakaway coupling;
- Dropped object onto the subsea export system;
- Damage to the subsea export system due to anchor drag during project activities between the north face of WNB and the CALM Buoy; or
- Internal or external corrosion of offloading system components (including export riser, PLEM and CALM Buoy pipework).

As the offtake process is continuously supervised, any release would be seen by the tanker or Facility personnel, and the offtake pumps would be stopped. This is considered to limit the volume of the release to a maximum of 300m³ of crude oil.

There is the potential for the marine breakaway coupling to part during periods between offtakes. Conservatively a maximum of 30m³ of crude is contained within the length of the FHA during

normal operations, with 5m^3 of crude stored within the sections beyond the marine breakaway coupling. If the marine breakaway coupling was to part, the floating hose sections may act as a 'vessel' to transport crude to a shoreline or sensitive location. Marine breakaway couplings however are unlikely to contain the full volume of crude as a complete seal cannot be achieved. The contents of the floating hose sections are therefore likely to seep from the floating hose over a short period of time within the surrounding open ocean. Given the potential for crude to also leak from the attached FHA during a period of time until detection, the maximum volume of crude released to the surrounding marine environment is considered to be up to a maximum of 30m^3 .

Controls to prevent these events include:

- A hawser fit for purpose;
- The use of a marine breakaway coupling on the FHA which is designed to part before the body of the hose. Once the coupling breaks in preference to the hose body it will isolate the oil contents away from the environment, reducing the potential spill size should the hose body have parted;
- Holdback device to prevent the FHA end section floating away following spurious activation of the MBC;
- Structural integrity of CALM Buoy mooring;
- Static tow operations;
- Management controls over the offtake operation including weather restrictions and use of a Mooring master on the tanker.

6.3.2.3 Breach of an oil tanker cell ($10,000\text{m}^3$ of Wandoo Crude)

A breach of an oil offtake tanker cell may occur due to a collision with the Facility or a vessel.

The most likely scenario would be the rupture of a single oil tanker cell. Therefore, the maximum credible volume of crude oil that may be accidentally released from the tanker is based on the volume of the largest tanker cell. The volume of the largest tanker cell in the most commonly used tanker is $5,500\text{m}^3$. Applying the precautionary approach, a spill of $10,000\text{m}^3$ was modelled to allow for variations in cell size.

Note that this event is the largest assumed release volume associated with offloading events.

The tanker position is controlled by support vessel, which must be present to assist with each offtake operation and must remain connected to the Tanker, providing static tow, throughout the offtake in accordance with the SPM Marine Facility Procedures [WPA-7000-YV-0002].

These requirements include a Southern cautionary and exclusion zone established to prevent impact with WNB in the event of loss of station keeping.

The controls for this event are common for other hazards associated with collision and include communication and navigation systems, management systems (500m restricted zone, weather restrictions, Mooring Master on tankers, SIMOPS matrix).

The feasibility of installing and using AIS (Automatic identification system) on the Wandoo facilities is currently being assessed.

6.3.2.4 *Breach of oil tanker's fuel tank (1,300m³ HFO)*

The offtake tankers that will berth at the CALM Buoy at the Wandoo Facility may use HFO as their fuel source. The location of fuel tanks at the sides of the vessel results in a potential for release of HFO as a result of a side impact by another vessel. A review of credible spill scenarios has determined that a credible risk exists for a support vessel to collide with the side of the moored offtake tanker potentially rupturing a HFO tank.

The maximum credible volume of HFO that may be accidentally released from a tanker in the event of a collision is based on the volume of the largest tanker cell. The volume of the largest HFO cell in the most commonly used tanker is 1,300m³.

The controls for this event are common for other hazards associated with collision, and include communication and navigation systems, as well as management systems (500m restricted zone, weather restrictions, Mooring Master on tankers, SIMOPS matrix).

6.3.3 **Impact assessment**

6.3.3.1 *Impact assessment criteria*

Refer to Appendix 3 for the impact assessment criteria for a liquid hydrocarbon release.

6.3.3.2 *Loss of crude oil from export system (<300m³ of Wandoo Crude)*

A subsea release will behave differently from a surface spill. Initially, the plume will rise until it reaches the surface, after which it will largely behave like a surface release. However, the level of entrainment is higher for a subsurface release, and the rate of entrainment largely depends on the exit velocity. A small leak at high pressure, which continues over an extended duration, will result in a much higher rate of entrainment (due to droplet formation as the hydrocarbons exit at high velocity) than a much larger aperture, where the same volume is released over a much shorter period.

Conservatively a maximum of 30m³ of crude is contained within the length of the FHA during normal operations, with <5m³ of crude stored within the sections beyond the marine breakaway coupling. A surface spill from a failure of the marine breakaway couple or FHA would be relatively instantaneous.

Due to the small potential spill volume, any impacts are anticipated to be localised and short term in nature. The closest sensitive habitats to the Operational Area are located in the Dampier Archipelago and Montebello Islands, 40km and 90km from the Operational Area respectively. As a significantly larger instantaneous spill of 10,000m³ has only a low probability of impacting these habitats (Section 6.3.3.3), it is considered highly unlikely that crude from the above spill scenarios would reach these habitats.

Minor impacts could occur on fauna in the immediate vicinity of the spill, including plankton, fish, marine mammals, reptiles and seabirds. Detailed descriptions of the potential effects of hydrocarbons on the surrounding marine environment in the event of a loss of well control (4,364m³) and instantaneous spill from the CGS (39,747m³) are provided in Sections 6.2.3 and 6.4 respectively. The impacts associated with a 300m³ spill would be significantly less and considered as 2: Minor.

6.3.3.3 Breach of an oil tanker cell (10,000m³ of Wandoo Crude)

Spill modelling summary

RPS APASA undertook spill trajectory modelling on an instantaneous 10,000m³ surface release of Wandoo Crude (tracked for 40 days) using summer, winter and transitional wind and current conditions (APASA, 2013c). A stochastic model was used to stimulate multiple trajectories (50 per season and threshold) and is graphically reported herein to show the spatial extent relative to thresholds in each hydrocarbon phase.

The objectives of this modelling were to determine the following:

- The maximum level of sea surface exposure;
- The probability and maximum time to shoreline contact;
- The average volume of oil to shoreline; and
- The maximum exposure to entrained hydrocarbons.

Each scenario was modelled with and without dispersant to assess the benefit of application.

Sea surface exposure

The cumulative probability (0-5%) of sea surface exposure at a sea surface thickness threshold of 1µm (or 1g/m²) for 10,000m³ instantaneous release of Wandoo Crude is outlined in Figure 6-1. The results were based on 50 oil spill trajectories during summer, winter and transitional conditions for an 80-day model period.

The modelling results indicate that once on the sea surface, the crude oil was predicted to travel northwest due to the prevailing winds during summer conditions. The oil contacts the shorelines on or about Day 30 at the southern end of Eighty Mile Beach, north of Port Hedland.

The application of dispersant does not have any impact on the sea surface oil thicknesses during summer or winter conditions.

The application of dispersant reduced the sea surface oil thickness by 15% during transitional conditions.

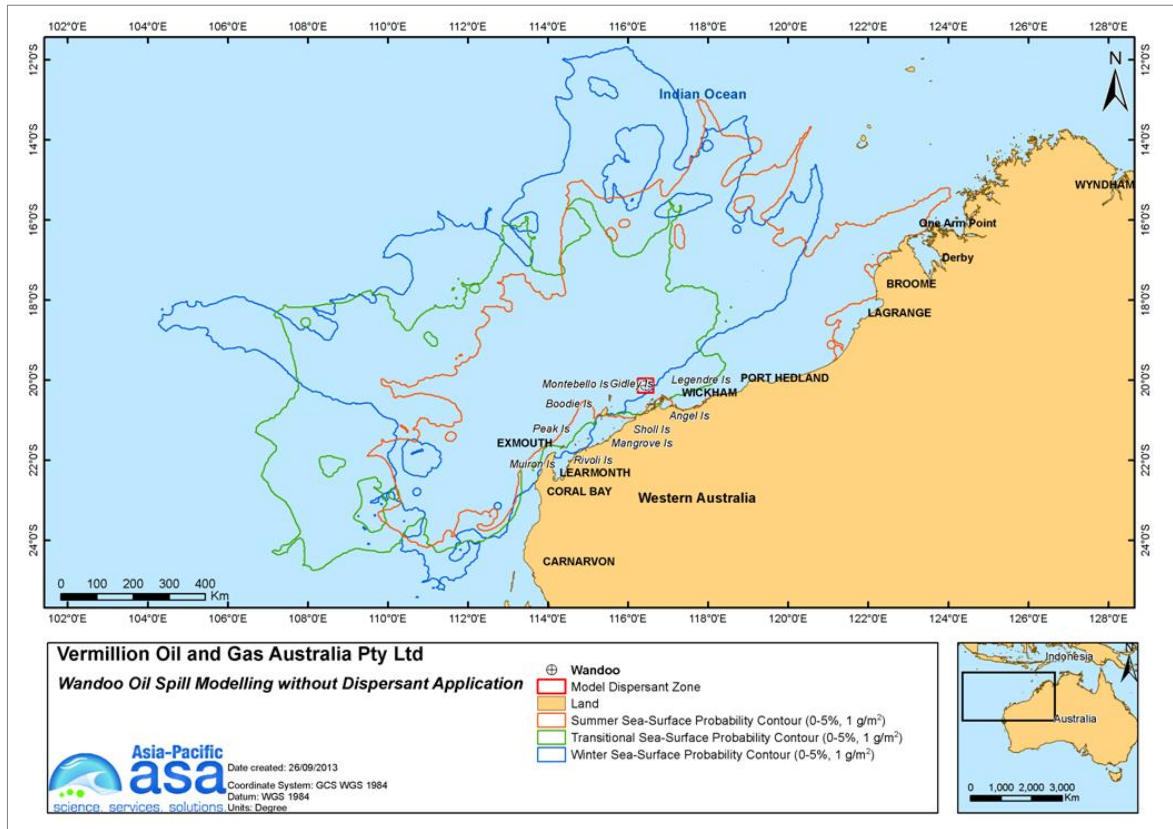

Figure 6-1: Probability (0-5%) of sea surface exposure (reported to 1µm or light exposure) in the event of a 10,000m³ instantaneous surface release of Wandoo Crude during summer, winter and transitional conditions

The modelling results predict that the surface crude oil would travel in a westerly direction propelled by strong prevailing winds during winter conditions. The plume would contact the Montebello Islands on Day 2, then Barrow Island on Day 5. The results indicate that the plume initially travelled in a westerly direction before moving offshore.

Additional analysis of the results identified that the leading edge of a slick could reach the Montebello AMP within 23 hours during winter conditions and travel on to contact sensitive shoreline (4% probability).

Shoreline accumulation

Table 6-16, Table 6-17 and Table 6-18 provide a summary of predicted shoreline contact, minimum time to contact and average oil volume on shore to various mainland and island coastlines in the event of a 10,000m³ instantaneous surface release of Wandoo Crude tracked for 40 days during summer, transitional and winter conditions. The spill was modelled with and without dispersant.

The probability of shoreline contact was highest during summer and lowest during winter. The minimum time to contact was also lowest during winter conditions (2.5 days). The application of dispersant did not have a significant impact on the probability of shoreline contact. The largest reduction in probability of contact was 2% during winter conditions. The application of dispersant had a minimal impact on time to contact during winter and transitional conditions. However, the

application of dispersant has the potential to reduce the time to shoreline contact by 5.4 days during summer conditions.

The application of dispersant during summer conditions has the potential to reduce the average volume onshore from Port Hedland to Broome and Broome to the Kimberley by 273m³ and 300m³ respectively. The average length of shoreline contacted above 10g/m², was predicted to drop by 3.0km and 5.3km between Port Hedland to Broome and Broome to the Kimberley, respectively. There was no significant change predicted to other ecologically significant shorelines.

The application of dispersant has the potential to reduce the average volume of oil onshore for the Dampier Archipelago by 300m³ during transitional conditions. The average length of shoreline contacted above 10g/m², was predicted to drop by 1.8km. The application of dispersant had no impact on the average volume of oil on the shoreline during winter conditions.

Entrained hydrocarbons

Summer

Potential zones of exposure from entrained (0-10m) hydrocarbons in the water column are outlined in Figure 6-2. The extent of entrained hydrocarbons changed considerably as expected when dispersant was applied from <40km to >300km from the release site. Without the use of dispersant, subsurface plumes remained localised and were mostly limited to the low exposure threshold, with the exception of a small moderate exposure zone surrounding the release site. When dispersant was applied, the subsurface plume at both the low and moderate exposure thresholds travelled predominantly southwest reaching waters surrounding the Montebello Islands, Peak Island and the islands in between. An isolated patch of potential high exposure from entrained hydrocarbons was <10km west from the release site.

Transitional

Potential zones of exposure from entrained oil (0-10m) with and without dispersant application are outlined in Figure 6-3. Without the use of dispersant, subsurface plumes remained localised and were limited to the low exposure threshold. The extent of entrained hydrocarbons changed considerably when dispersant was applied from <40km to >300km from the release site. When dispersant was applied, the subsurface plume at both the low and moderate exposure thresholds travelled predominantly southwest reaching Exmouth. Isolated patches of potential high exposure from entrained hydrocarbons were predicted within 20km from the release site.

Winter

The potential zone of entrained hydrocarbon exposure is outlined in Figure 6-4. Without the use of dispersant, subsurface were limited to the low exposure threshold and within 50km of the release site. The extent of entrained hydrocarbons changed considerably when dispersant was applied from <50km to >300km from the release site. When dispersant was applied, the subsurface plume at the low threshold travelled predominantly southwest reaching Onslow and Exmouth. Isolated patches of potential high exposure from entrained hydrocarbons were within 20km from the release site.

Potential impacts

Detailed descriptions of the potential effects of hydrocarbons on the surrounding marine environment in the event of a loss of well control (4,364m³) and instantaneous spill from the CGS

(39,747m³) are provided in Sections 6.2 and 6.4 respectively. The impacts associated with a 10,000m³ spill would be commensurate with the loss of well control spill scenario and significantly less than the CGS spill.



Table 6-16: Comparison of the predicted shoreline contact, minimum time to contact and average oil volume on shoreline to areas of interest with and without the application of dispersant, in the event of an instantaneous 10,000m³ sea surface release of Wandoo Crude. The results were calculated from the 50 oil spill trajectories (each case) and are reported to thresholds of 1, 10 and 100g/m², respectively, during summer conditions

Region	Probability of contact for reported threshold (%)						Minimum time to contact (days) for reported threshold						Average oil volume on shoreline (m3)	
	With dispersant			Without dispersant			With dispersant			Without dispersant			With dispersant	Without dispersant
	Threshold (g/m ²)			Threshold (g/m ²)			Threshold (g/m ²)			Threshold (g/m ²)				
	1	10	100	1	10	100	1	10	100	1	10	100		
Exmouth to Dampier	6	5	5	6	5	5	9.1	9.1	9.1	3.7	3.7	3.7	38.4	36.4
Barrow Island	2	2	1	2	1	1	30.0	30.0	30.0	29.9	31.1	31.1	44.6	35.3
Lowendal Islands	2	2	2	2	2	2	31.5	31.5	31.5	32.0	32.0	32.0	7.5	7.4
Montebello Islands	3	2	2	3	2	2	3.5	3.6	3.8	3.5	3.6	3.9	24.2	25.7
Northern Group	1	1	1	1	1	1	32.6	32.6	32.6	32.6	32.6	32.6	273.8	275.1
Dampier Archipelago	4	4	3	5	3	3	9.1	9.1	9.1	9.2	9.8	9.8	94.6	104.4
Dampier to Port Hedland	4	4	4	6	4	4	11.2	11.3	11.3	9.8	11.2	11.2	57.5	79.4
Port Hedland to Broome	15	9	8	15	9	8	13.3	16.4	16.4	11.3	14.4	14.4	1,437.4	1,710.6
Rowley Shoals Marine Park	6	6	6	5	5	5	22.4	22.4	22.4	24.5	24.5	24.5	45.4	34.5
Broome to Kimberleys	3	3	3	3	3	3	34.2	34.2	34.2	32.8	34.1	34.1	242.9	543.4



Table 6-17: Comparison of the predicted shoreline contact, minimum time to contact and average oil volume on shoreline to areas of interest with and without the application of dispersant, in the event of an instantaneous 10,000m³ sea surface release of Wandoo Crude. The results were calculated from the 50 oil spill trajectories (each case) and are reported to thresholds of 1, 10 and 100g/m², respectively, during transitional conditions

Region	Probability of contact for reported threshold (%)						Minimum time to contact (days) for reported threshold						Average oil volume on shoreline (m ³)	
	With dispersant			Without dispersant			With dispersant			Without dispersant			With dispersant	Without dispersant
	Threshold (g/m ²)			Threshold (g/m ²)			Threshold (g/m ²)			Threshold (g/m ²)				
	1	10	100	1	10	100	1	10	100	1	10	100		
Exmouth to Dampier	4	3	3	4	3	3	4.1	4.4	4.4	4.1	4.4	4.4	2.4	4.0
Barrow Island	2	2	2	2	2	2	28.3	28.3	28.3	27.3	27.3	27.3	12.4	9.9
Lowendal Islands	2	1	1	1	1	1	27.0	31.3	31.3	31.3	31.3	31.3	6.6	6.6
Montebello Islands	10	8	6	8	6	6	4.4	4.4	4.4	4.5	4.5	4.5	55.8	64.0
Northern Group	3	3	3	2	2	2	21.3	27.1	27.1	25.0	27.3	27.3	40.1	47.5
Dampier Archipelago	3	3	3	3	3	3	20.3	20.3	20.3	20.4	20.4	20.4	448.7	646.6
Dampier to Port Hedland	3	3	3	3	3	3	10.3	10.3	10.3	10.4	10.4	10.4	67.3	105.1
Port Hedland to Broome	-	-	-	-	-	-	-	-	-	-	-	-	-	-
Rowley Shoals Marine Park	-	-	-	-	-	-	-	-	-	-	-	-	-	-
Broome to Kimberleys	-	-	-	-	-	-	-	-	-	-	-	-	-	-



Table 6-18: Comparison of the predicted shoreline contact, minimum time to contact and average oil volume on shoreline to areas of interest with and without the application of dispersant, in the event of an instantaneous 10,000m³ sea surface release of Wandoo Crude. The results were calculated from the 50 oil spill trajectories (each case) and are reported to thresholds of 1, 10 and 100g/m², respectively, during winter conditions

Region	Probability of contact for reported threshold						Minimum time to contact (days) for reported threshold and the corresponding total predicted quantity (g/m ²)						Average oil volume on shoreline (m ³)	
	With dispersant			Without dispersant			With dispersant			Without dispersant			With dispersant	Without dispersant
	Threshold (g/m ²)			Threshold (g/m ²)			Threshold (g/m ²)			Threshold (g/m ²)				
	1	10	100	1	10	100	1	10	100	1	10	100	1	10
Exmouth to Dampier	2	2	1	2	1	1	20.4	20.4	20.4	20.3	20.3	20.3	0.1	0.1
Barrow Island	6	4	4	6	3	3	4.1	4.2	4.2	4.2	4.2	4.2	6.6	6.9
Lowendal Islands	3	3	3	3	3	3	4.2	5.0	5.0	4.0	4.5	4.9	18.0	10.0
Montebello Islands	7	6	3	5	4	3	2.5	2.5	2.5	2.5	2.5	2.5	22.1	28.6
Northern Group	-	-	-	-	-	-	-	-	-	-	-	-	-	-
Dampier Archipelago	-	-	-	-	-	-	-	-	-	-	-	-	-	-
Dampier to Port Hedland	-	-	-	-	-	-	-	-	-	-	-	-	-	-
Port Hedland to Broome	-	-	-	-	-	-	-	-	-	-	-	-	-	-
Rowley Shoals Marine Park	4	4	4	4	4	4	25.5	25.5	25.5	25.0	25.0	25.0	32.6	45.7
Broome to Kimberleys	-	-	-	-	-	-	-	-	-	-	-	-	-	-

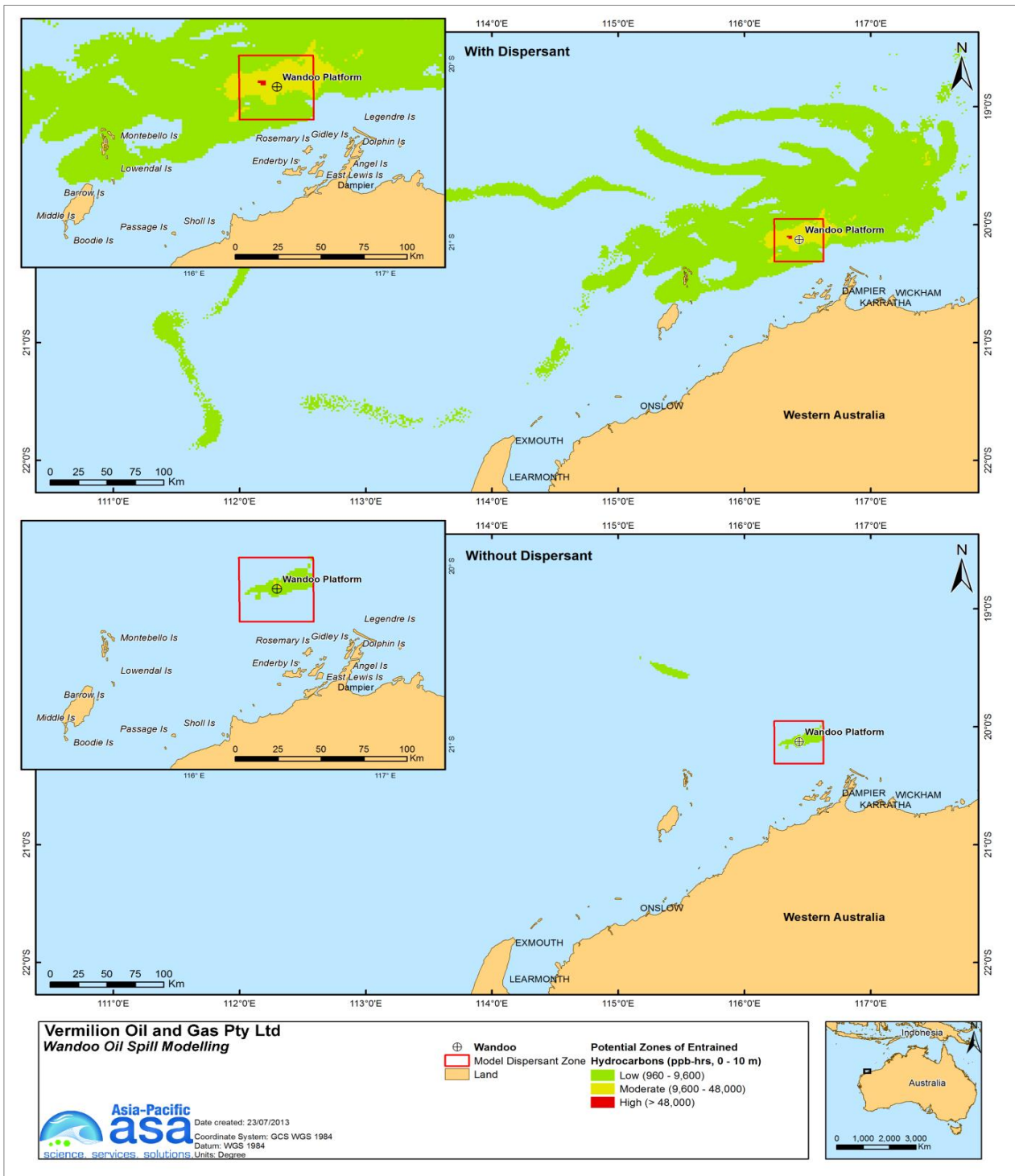

Figure 6-2: Potential zone of entrained hydrocarbon exposure at 0-10m depth in the event instantaneous 10,000m³ sea surface release of Wandoo Crude (top) with dispersant; and (bottom) without dispersant. The results were calculated from the 50 oil spill trajectories (each case), during summer conditions

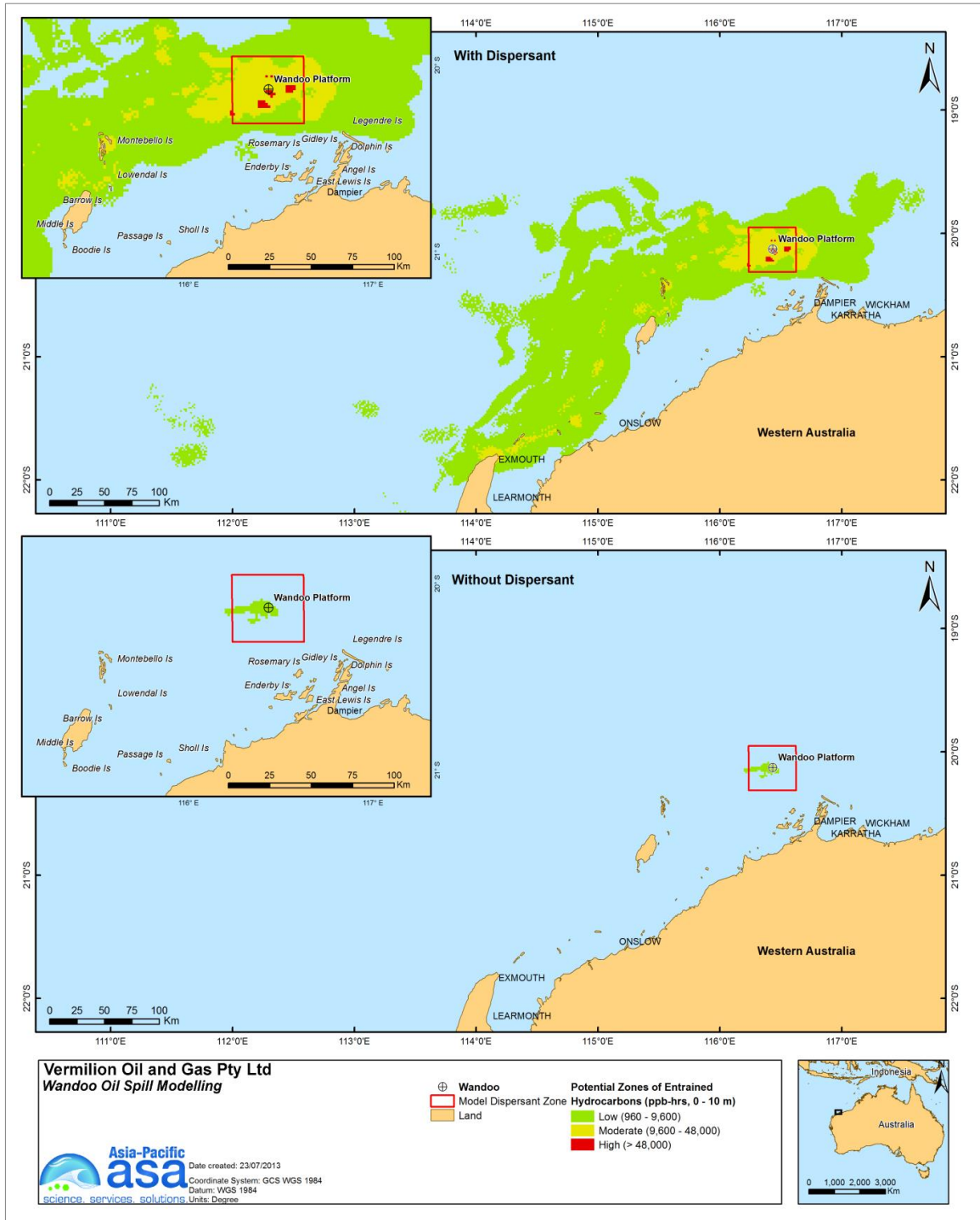

Figure 6-3: Potential zone of entrained hydrocarbon exposure at 0-10m depth in the event instantaneous 10,000m3 sea surface release of Wandoo Crude (top) with dispersant; and (bottom) without dispersant. The results were calculated from the 50 oil spill trajectories (each case), during transitional conditions

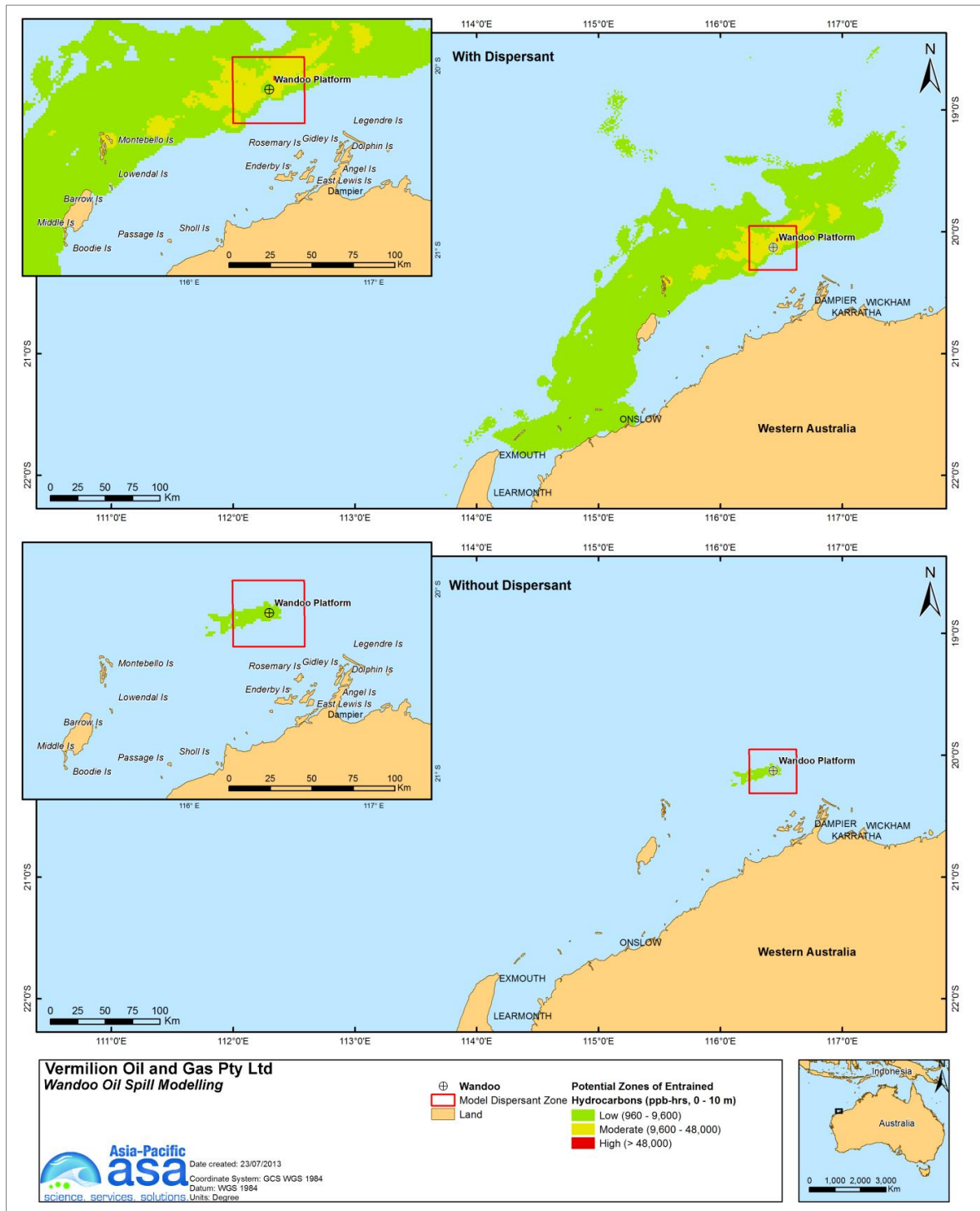

Figure 6-4: Potential zone of entrained hydrocarbon exposure at 0-10m depth in the event instantaneous 10,000m³ sea surface release of Wandoo Crude (top) with dispersant; and (bottom) without dispersant. The results were calculated from the 50 oil spill trajectories (each case), during winter conditions

6.3.3.4 Breach of oil tanker's fuel tank (1,300m³ of HFO)

HFO is classified as a Group IV hydrocarbon (AMSA, 2011; DoT, 2010). The specific characteristics of the HFO will vary depending on the type of HFO used. HFO is a heavy, viscous, slowly spreading oil that loses little volume through evaporation of volatile components with a high proportion (83%) of persistent, non-volatile residual components (boiling point greater than 380°C). HFO has little to no tendency to entrain within the water column; it is also unlikely to disperse and biodegrade rapidly due to its persistent characteristics. However, it may form emulsions with seawater and form a stable 'mousse' under some conditions. Spill modelling for HFO was not undertaken as the impacts associated with this event are considered to be similar to those described for the surface crude oil release <10,000m³ (Section 6.3.3.3), as HFO, a Group IV Category oil has similar properties as Wandoo Crude.

Results of OSTM for the instantaneous 10,000m³ release of Wandoo Crude show that the 10g/m² has a low probability of reaching shoreline habitats for all seasons (Table 6-16 to Table 6-18). The highest of shoreline contact for the 10g/m² thresholds was 9% during the summer season, based on 50 spill trajectories. The shortest minimum time to shoreline contact was 2.5 days during the winter season. As the OSTM for the 10,000m³ scenario showed that Wandoo Crude has a low probability of contacting shorelines, it is considered unlikely that 1,300m³ of HFO would reach these habitats.

Potential physical impacts from HFO floating at the sea surface include coating of emergent habitats, oiling of wildlife at sea surface, and ingestion. HFO is a particularly persistent oil which has a high degree of stickiness, and therefore oiling of habitats and fauna by residual oil is the exposure pathway of greatest concern. The degree to which impacts could occur will depend upon the level of coating (concentration of oil and/or loading of oil on shorelines) and how fresh the oil is, with toxicity from oil contact likely to be more prevalent from 'fresh' oil closer to the Wandoo Facility.

Detailed descriptions of the potential effects of hydrocarbons on the surrounding marine environment in the event of a loss of well control (4,364m³) and instantaneous spill from the CGS (39,747m³) are provided in Sections 6.2 and 6.4 respectively. The impacts associated with a 1,300m³ HFO spill would be less than the loss of well control spill scenario and significantly less than the CGS spill.

6.3.4 Catastrophic Environmental Event identification

As discussed in Section 6.3.2 and 6.3.3 above, catastrophic impacts would only result from a complete and sudden loss of containment of offtake tanker crude oil (10,000m³).

The identified CEE is therefore designated as CEE-02 – Liquid hydrocarbon release from offtake tanker crude oil.

6.3.5 Critical Controls identification

In accordance with the process described in Section 5.4.2 all controls for CEE-02 – Liquid hydrocarbon release from offtake tanker crude oil have been assessed for criticality. This assessment has resulted in a concise listing of identified Critical Controls as provided in Table 6-19.

Table 6-19: CEE-02 Critical Controls

Hazard	Activity/Cause/Mitigation	Critical Control
CEE-02 Liquid hydrocarbon release from offtake tanker crude oil	Vessel collision with tanker whilst on station and connected to the Wandoo asset.	Navigation aids. CALM Buoy Mooring System Emergency communications.
	Mitigation	Wandoo Emergency Response Plan [VOG-2000-RD-0017]/Wandoo Field OSCP [WAN-2000-RD-0001].

6.3.6 Oil spill response strategies (mitigation)

6.3.6.1 Overview

Section 6.3.6 summarises the process undertaken to mitigate the hazard scenarios described and assessed in Sections 6.3.2 and 6.3.3 respectively. To support a hazard based approach to planning, oil spill scenarios outlined in this EP were grouped into spill categories based on fluid type, duration, and volume.

The hazards, impacts and the controls required to manage the environmental impact of the oil spill response strategies are outlined in Section 6.5. The impacts of the response strategies were considered in the strategy selection process.

6.3.6.2 Loss of crude oil from export system (<300m³ of Wandoo Crude)

The spill category which covers this hazard is 'A'.

Assessments of the benefits of the oil spill response strategies that are considered feasible to respond to this spill are provided in Table 6-20. The response strategies not considered feasible are outlined in Table 6-17.

Table 6-20: Feasibility and benefits of response strategies for Category A

Oil spill response strategy	Feasible	Benefits
Source control	Yes	Isolation of ruptured section of flow line, flow stopped or redirected, thus minimising the potential spill volume. Subsea inspection and repair to follow. Preventative inspections and maintenance carried out periodically. This is an important mitigation measure once a spill has occurred, to reduce the volume of oil reaching the marine environment.
Monitor and evaluate	Yes	Monitoring and evaluation provides information on the behaviour and likely trajectory of the spill. This will be used to evaluate the appropriate response strategy.

Oil spill response strategy	Feasible	Benefits
Chemical dispersion	Yes	Chemical dispersion assists with the natural dispersion process, encouraging the slick to mix and suspend within the water column where it can be more easily biodegraded. This is likely to be used to reduce the impact of surface oil on environmental sensitivities. Laboratory results show that chemical dispersant is effective on weathered and unweathered samples of Wandoo Crude, and dispersant can achieve an efficacy of up to 65% within 8 hours of application (Intertek, 2012). Regardless of season, a dispersant test spray run will be undertaken prior to moving to full dispersant application operations to verify its effectiveness. Real time operational information and spill location will also be used to determine the net environmental benefit of dispersant application.
Containment and recovery	Possible	Containment and recovery can be used to recover oil to prevent it impacting on environmental, social and cultural sensitivities. Containment and recovery may be effective on Wandoo Crude as it is a persistent crude oil with a high specific gravity and viscosity. Depending on metocean conditions, containment and recovery is expected to have a removal rate of 10 to 15% (ITOPF, 2013). Containment and recovery will be used if metocean conditions are suitable and if oil is of suitable thickness.
Mechanical dispersion	Possible	Mechanical dispersion assists with the natural dispersion process, encouraging the slick to mix and suspend within the water column where it can be more easily biodegraded. Once dispersed in the water column the smaller droplet size enhances the natural biodegradation process. It may be used to assist chemical dispersion when sea conditions are calm. Used when surface oil presents a greater risk to the marine environment than entrained oil.
Oiled wildlife response	Possible	This is applicable for marine fauna that come close to the spill or become oiled. Care is to be taken not to injure animals or drive animals into the spill, or split up the pods, schools and flocks.

The response strategies will be implemented in accordance with the Wandoo Field OSCP [WAN-2000-RD-0001].

Table 6-21: Response strategies not considered feasible for Category A

Oil spill response strategy	Feasible	Considerations
Protection and deflection	No	Protection and deflection can be used to protect sensitive receptors though the use of booms to create physical barriers on the water surface. Corraling is generally effective on persistent oils such as Wandoo Crude. The effectiveness of protection and deflection depends on the thickness of the oil, and weather and sea state conditions. It is unlikely that protection and deflection will be used in this case as shoreline contact is not predicted.
Shoreline clean-up	No	Shoreline clean-up is unlikely to be used as shoreline contact is not predicted.

Oil spill response strategy	Feasible	Considerations
In-situ burning	No	Is not considered feasible as Wandoo Crude has not been proven to be amenable to in-situ burning. Also, the required equipment, technology and training are not available in Australia for operators using this technique. No accelerants are currently listed on the National Plan Register for OSCA.

6.3.6.3 Breach of oil tanker (10,000m³ Wandoo Crude)

The oil spill response strategies considered feasible/not feasible for this spill are as per the liquid hydrocarbon release from wells outlined in Section 6-2. The impacts of the oil spill response strategies are assessed in Section 6.5.

6.3.6.4 Breach of tanker fuel tank (1,300m³ HFO)

Assessments of the benefits of the oil spill response strategies that are considered feasible to respond to this spill are provided Table 6-22. The response strategies not considered feasible are outlined in Table 6-23.

Table 6-22: Feasibility and benefits of response strategies for Category C

Oil spill response strategy	Feasible	Benefits
Monitor and evaluate	Yes	Monitoring and evaluation provides information on the behaviour and likely trajectory of the spill. This will be used to evaluate the appropriate response strategy.
Chemical dispersion	Yes	Chemical dispersion assists with the natural dispersion process, encouraging the slick to mix and suspend within the water column where it can be more easily biodegraded. HFO is a persistent hydrocarbon that does not disperse easily in the natural environment. To verify its effectiveness, a dispersant test spray run will be undertaken prior to moving to full dispersant application operations. An operational SIMA will be undertaken to determine the net environmental benefit of dispersant application.
Containment and recovery	Yes	Containment and recovery can be used to recover oil to prevent it impacting on environmental, social and cultural sensitivities. The effectiveness of containment and recovery depends on the thickness of the oil, and weather and sea state conditions. Containment and recovery may be effective on HFO as it is a persistent hydrocarbon with a high viscosity.
Mechanical dispersion	Possible	Mechanical dispersion assists with the natural dispersion process, encouraging the slick to mix and suspend within the water column where it can be more easily biodegraded. Once dispersed in the water column, the smaller droplet size enhances the natural biodegradation process. It may be used to assist chemical dispersion when sea conditions are calm. Used when surface oil presents a greater risk to the marine environment than entrained hydrocarbons.
Oiled wildlife response	Possible	This is applicable for marine fauna that come close to the spill or become oiled. Care to be taken not to injure animals or drive animals into the spill, or split up the pods, schools and flocks.

The response strategies will be implemented in accordance with the Wandoo Field OSCP [WAN-2000-RD-0001].

Table 6-23: Response strategies not considered feasible for Category C

Oil spill response strategy	Feasible	Considerations
Protection and deflection	No	Protection and deflection can be used to protect sensitive receptors though the use of booms to create physical barriers on the water surface. Corraling is generally effective on persistent oils such as Wandoo Crude. The effectiveness of protection and deflection depends on the thickness of the oil, and weather and sea state conditions. It is unlikely that protection and deflection will be used in this case as shoreline contact is not predicted.
Shoreline clean-up	No	Shoreline clean-up is unlikely to be used as shoreline contact is not predicted.
In-situ burning	No	Is not considered feasible as HFO has not been proven to be amenable to in-situ burning. Also, the required equipment, technology and training are not available in Australia for operators using this technique. No accelerants are currently listed on the National Plan Register/OSCA.

6.3.7 Risk ranking

6.3.7.1 Consequence

Loss of crude oil from export system (<300m³ of Wandoo Crude)

As discussed in Sections 6.3.2.2 and 6.3.3.2 the offtake process is considered to limit the volume of the release to a maximum of 300m³ of crude oil. Therefore, a consequence ranking of '3' (Moderate) was considered appropriate given the potential environmental impacts.

As discussed in Sections 6.3.2.2 and 6.3.3.2 a maximum of 30m³ of crude is contained within the length of the FHA during normal operations, with <5m³ of crude stored within the sections beyond the marine breakaway coupling. A consequence ranking of '3' (Moderate) was considered appropriate given the potential environmental impacts from the FHA if transported to a sensitive shoreline.

Breach of oil tanker (10,000m³ Wandoo Crude)

As discussed in Sections 6.3.2.3 and 6.3.3.3 the volume of the largest tanker cell in the most commonly used tanker is 5,500m³. A precautionary approach was applied, increasing the volume of a potential spill to 10,000m³. A consequence ranking of '5' (Catastrophic) was considered appropriate given the potential environmental impacts.

Breach of tanker fuel tank (1,300m³ HFO)

As discussed in Sections 6.3.2.4 and 6.3.3.4 the maximum credible volume of HFO that may be accidentally released from a tanker in the event of a collision is based on the volume of the largest tanker cell (1,300m³). A consequence ranking of '4' (Major) was considered appropriate given the potential environmental impacts.

6.3.7.2 Likelihood

The release frequency from the export system has been assessed in the Wandoo B Flammable Hazards Analysis [WNB-3000-RH-0013] as 7.9E-05 and so a likelihood ranking of A: Rare is appropriate.

Due to incidents involving the FHA in the Wandoo field a likelihood of “C”: Possible is appropriate for a release from the FHA.

The manoeuvring vessel collision with the tanker is 2.87×10^{-4} per year. The probability of the vessel being sufficiently large and the impact to be in such a location to result in a hydrocarbon release from the offtake tanker would be significantly less frequent (at least an order of magnitude). This is because the tanker could disconnect and move out of the way before impact, or if the tanker’s propulsion systems were impaired, the static tow could tow the tanker out of the way. Furthermore, glancing blows would be unlikely to result in a catastrophic failure. Therefore, the likelihood of this event resulting in a worst-case environmental impact is assessed as “A rare”.

6.3.7.3 Residual Risk ranking

This results in residual risk levels of:

- 3A – Low risk for Loss of crude oil from export system;
- 3C – Medium risk for Loss of crude oil from the FHA;
- 5A – Medium risk for breach of oil tanker; and
- 4A – Medium risk for breach of tanker fuel tank.

The worst-case residual risk ranking for liquid hydrocarbon release from export equipment, submarine hose, floating hose and export flow lines is therefore Medium (RRII).

6.3.8 ALARP demonstration

6.3.8.1 Overview

The risk associated with a release of hydrocarbon from the export system is inherent to the operation of an offshore petroleum facility however these risks can be managed through the implementation of effective control measures and associated performance monitoring.

The ALARP assessment concluded that the risks are being managed to ALARP as:

- There are sufficient layers of protection in place for the current risk level; and
- Additional controls and alternative arrangements were not considered to be practical due to the associated increase to other risks.

6.3.8.2 Existing controls

The hazard summary in Section 6.6 describes the controls for this hazard. The range of controls includes multiple independent layers of protection, including:

- Design specification of FHA and submarine hose assembly and marine breakaway coupling;

- The export system is covered under the Asset Integrity Management System to ensure that they are fit for service. The asset integrity system monitors condition of the asset and coupled with asset life extension/asset replacement processes ensure that loss of containment from the export system is minimised;
- Supply vessel traffic within the field is required for operations and maintenance of the Wandoo facilities. Their presence in the field during export operations is restricted and managed via SIMOPS arrangement; and
- The platform ESD system isolates hydrocarbon inventories and shuts down export pumps.

6.3.8.3 *Source control*

The management of resources, information and communications via the implementation of established procedures is absolutely essential for effective emergency response in order to ensure protection of life, property and the environment.

The VOGA Source Control Contingency Plan [WNB-3000-PD-0007] provides a guideline to the required response and event hierarchy to a well control event, either contained or uncontained and the processes that shall be followed in the event of a well control incident during well construction and/or intervention operations in the Wandoo Field.

6.3.8.4 *Oil spill response strategy and resources*

Overview

The response strategies to reduce the environmental impact are from this hazard scenario are outlined 6.3.6 and are implemented through the Wandoo Field OSCP [WAN-2000-RD-0001]. VOGA has a spill preparedness planning process that identifies suitable spill response strategies which:

- Are consistent with the hazard profile;
- VOGA's response strategies and procedures to reduce the volume of hydrocarbons spilt and reduce the environmental impact are outlined in the Wandoo Field OSCP [WAN-2000-RD-0001]. These response strategies are consistent with those outlined in the National Plan;
- Considers the benefits of each strategy as outlined in Section 6.3.6; and
- Considers the risks and impacts of each strategy as outlined in Section 6.5.

The spill response planning process is described in Section 7.9.2.2 and results in spill response which will best mitigate the environmental impacts of this hazard scenario.

The spill response ALARP demonstration is based on the findings from the liquid hydrocarbon release from wells (Section 6.2.7). This spill scenario was considered to have the greatest demand from oil spill response requirements based on the spill impact assessment and extended duration of response.

Monitor and evaluate

The ALARP review of the proposed response strategy tactics and resources is provided in Table 6-7.

Dispersant application

The ALARP review of the proposed response strategy tactics and resources is provided in Table 6-8.

Mechanical dispersion

The ALARP review of the proposed response strategy tactics and resources is provided in Table 6-9.

Containment and recovery

The ALARP review of the proposed response strategy tactics and resources is provided in Table 6-10.

Protection and deflection

The ALARP review of the proposed response strategy tactics and resources is provided in Table 6-11.

Shoreline clean-up

The ALARP review of the proposed response strategy tactics and resources is provided in Table 6-12.

Oiled wildlife response

The ALARP review of the proposed response strategy tactics and resources is provided in Table 6-13.

6.3.8.5 Additional control and alternative arrangements

VOGA carried out an assessment of alternative arrangements and additional controls to reduce risks:

An alternative to exporting via a tanker is a pipeline to shore. This arrangement is not only cost prohibitive but also could potentially introduce higher spill frequency, and impacts due to the pipeline length, inventory, and proximity to shoreline sensitivities. No additional controls were identified.

6.3.8.6 Conclusion

The ALARP assessment has concluded that the risks are being managed to ALARP because:

- There are sufficient layers of protection in place for the current risk level;
- In the unlikely event of spill from the export system, response strategies which match the hazard profile are defined in the Wandoo Field OSCP [WAN-2000-RD-0001] and will be implemented to reduce the impact of the spill to the environment. The resources to implement the response has been determined and evaluated to ensure that the response strategies can be achieved; and
- Additional controls and alternative arrangements were not considered to be practical due to the associated increase to other risks.

6.3.9 Acceptability demonstration

These risks are considered to be acceptable as:

- This is an inherent risk for an offshore petroleum facility, with a low frequency, and the controls and performance monitoring identified in this Wandoo Facility EP meet or exceed those typically applied for offshore petroleum operations;
- The alternative arrangements are not considered practical, increase associated safety and environmental risk, and/or are not sustainable from a cost or environmental impact view;
- All relevant Australian standards and codes of practice have been followed to ensure integrity and safe operation of the system minimising the potential for a loss of containment in the hydrocarbon export system;
- Ongoing stakeholder consultation undertaken for this Wandoo Facility EP did not generate any feedback regarding concerns due to spills from the hydrocarbon export system;
- With the preventative and mitigative controls in place, the conservation of biological diversity and ecological integrity shall be maintained; and
- In the event of a hydrocarbon spill, the activities, and the proposed performance management measures, meet the requirements of internal VOGA procedures that have been developed in accordance with relevant environmental legislation.



6.4 Crude oil spill from CGS

6.4.1 Hazard report

Table 6-24: Hazard report – Crude oil spill from CGS

HAZARD:	Crude oil spill from CGS					
EP risk no.:	EP-OP-R03					
CEE:	CEE-03 – Loss of Containment (CGS) - Crude oil spill from WNB CGS					
Potential impacts:	Potential release of hydrocarbon into sea from the largest CGS cell (39,747m ³) over a period of 24 hours.					
PREVENTION:						
Activity/cause:	Existing management controls	Control type	Control hierarchy	Performance outcome	Performance standard	Measurement criteria
Degradation/collapse of CGS shaft due to fatigue, corrosion of steel reinforcement, extreme storm etc.	Structural design of the CGS.	Engineering	Reduction	Manage structural integrity of the CGS to prevent structural collapse.	Inspection and weight management, as per WAN-WNAB-CE-PR-07-02.01 Substructure – CGS to ensure the CGS: <ul style="list-style-type: none"> Operated within acceptable load & distribution limits Physical condition and anomalous effects shall remain within acceptable limits. 	Assurance records, as per WAN-WNAB-CE-PR-07-01 – All structures.
	Asset integrity management	Administrative	Reduction		Performance criteria, as per WAN-WNAB-CP-PR-04-04 – Integrity Management. The integrity of critical elements shall be maintained at all times.	Assurance records, as per WAN-WNAB-CP-PR-04-04 – Integrity Management.
	MOC processes for changes to structural loading.	Administrative	Reduction		Performance criteria, as per WAN-WNAB-CP-PR-02-01 – MoC. A formal process shall be implemented to identify, assess, approve and manage all changes that have the potential to impact the safety, health or environmental risk levels associated with the facility.	Records of approved MoC documentation.
Passing vessel collision with Platform.	Emergency communications.	Engineering	Prevention	Prevent a crude oil spill oil to the marine environment from the CGS due to vessel collision.	Performance criteria, as per WAN-WNAB-CE-ES-02-01 – UHF/VHF Radios. To ensure communication between CCR and the Emergency Response Team (at any location on the installations), personnel on WNA, personnel on CALM Buoy and external parties.	Assurance records, as per WAN-WNAB-CE-ES-02-01 – UHF/VHF Radios.
	Navigation aids.	Engineering	Reduction		Performance criteria, as per: <ul style="list-style-type: none"> WAN-WNAB-CE-PR-06.01 - Navigation Lights. To provide visual indication to marine vessels of the position of the installation (WNA & WNB) so that they may take timely action to avoid the area. WAN-WNAB-CE-PR-06.02 - Fog Horn. To provide audible indication to marine vessels of the position of each fixed installation (WNA and WNB) so that they may take timely action to avoid the area. 	Assurance records, as per: <ul style="list-style-type: none"> WAN-WNAB-CE-PR-06.01 - Navigation Lights. WAN-WNAB-CE-PR-06.02 - Fog Horn.
	Platform location published on Marine Charts.	Administrative	Reduction		Wandoo facilities are marked on marine charts and any changes to Wandoo facilities notified via Notices to Mariners.	Records to confirm that Wandoo facilities are on chart and applicable Notice to Mariners.



PREVENTION:						
	500m restriction zone surrounding the facility.	Administrative	Reduction		500m restriction zone surrounding the facility, as per the Wandoo Marine Operations Manual [WNB-1000-YV-0001].	Wandoo Marine Operations Checklist.
Attending vessel collision with Platform.	Station keeping requirements for vessels.	Administrative	Reduction	Prevent the release of hydrocarbons to the marine environment due to vessel collision with the platform.	Dynamic positioning requirements, as per Section 9 of the Wandoo Marine Operations Manual [WNB-1000-YV-0001].	Wandoo Marine Operations Checklist.
	Vessel operations restricted in adverse weather.	Administrative	Reduction		Vessel operations restricted in adverse weather, as per the Wandoo Marine Operations Manual [WNB-1000-YV-0001].	Wandoo Marine Operations Checklist.
	Permission required for field entry, CALM Buoy approach, mooring-up and departure.	Administrative	Reduction		Vessels shall comply with permissioning protocols for vessels entering the field, CALM Buoy approach, mooring-up and departure, as per the Wandoo Marine Operations Manual [WNB-1000-YV-0001].	Wandoo Marine Operations Checklist.
Tanker station keeping failure.	CALM Buoy mooring system	Engineering	Reduction	Prevent the release of hydrocarbons to the marine environment due to tanker collision with the platform.	Performance criteria, ensuring inspection of CALM buoy mooring as per <ul style="list-style-type: none"> WAN-WNB-CE-PR-07-03. 01 - Mooring System - CALM Buoy, including mooring arm WAN-WNB-CE-PR-07-03. 02 - Mooring System - Chains and Anchors 	Assurance records, as per <ul style="list-style-type: none"> WAN-WNB-CE-PR-07-03. 01 - Mooring System - CALM Buoy, including mooring arm WAN-WNB-CE-PR-07-03. 02 - Mooring System - Chains and Anchors
	Hawser is fit for purpose.	Administrative	Reduction		Hawser, chains and shackles shall be visually inspected for mechanical damage and wear prior to offtake, as per the SPM Marine Facility Procedures [WPA-7000-YV-0002].	Offtake Maintenance Report.
	Weather restrictions apply to offtake activities.	Administrative	Reduction		Offtake operations shall be restricted in adverse weather, as per the SPM Marine Facility Procedures [WPA-7000-YV-0002].	Offtake Maintenance Report.
	Wandoo Mooring Master on board tanker during offtake.	Administrative	Reduction		Wandoo Mooring Master meets minimum competency standard as per contract	Training records confirmed for Mooring Master
	Static tow by support vessel to control tanker position	Engineering	Reduction		A support vessel shall be present to assist with each offtake operation and must remain connected to the Tanker, providing static tow, throughout the offtake as per as per the SPM Marine Facility Procedures [WPA-7000-YV-0002].	Safety Checklist



MITIGATION:					
Existing management controls	Control type	Control hierarchy	Performance outcome	Performance standard	Measurement criteria
Wandoo Emergency Response Plan [VOG-2000-RD-0017]/ CGS Source Control Plan [VOG-3000-YH-0001].	Administrative	Mitigation	To mitigate against the impact to the environment of hydrocarbons released in the event of a loss of CGS spill.	The Wandoo Emergency Response Plan [VOG-2000-RD-0017] and CGS Source Control Contingency Plan [VOG-3000-YH-0001] shall meet the performance criteria as per WAN-WNAB-CP-ER-01 – Emergency preparedness, management and response	Assurance criteria as per WAN-WNAB-CP-ER-01 - Emergency preparedness, managements and response.
Oil spill response arrangements	Administrative	Mitigation	To mitigate the environmental impacts as a result of oil spill, by ensuring that measures are in place to mitigate the oil spill hazards associated with activities within the Wandoo Field.	Performance criteria, as per WAN-WNAB-CP-ER-02; WAN-WNAB-CP-ER-03, WNAB-CP-ER-01-05 and WNAB-CP-ER-01-06 (refer to Hazard EP-OP-R01 Table 6-2)	Assurance activities, as per WAN-WNAB-CP-ER-02; WAN-WNAB-CP-ER-03, WNAB-CP-ER-01-05 and WNAB-CP-ER-01-06
INITIAL RISK WITH EXISTING CONTROLS:					
Consequence		Likelihood (of consequence)		Initial risk	
Catastrophic (5)		Rare (A)		Medium	
ADDITIONAL CONTROLS/DEMONSTRATION OF ALARP - VOGA WORKSHOP:					
A medium risk is defined as tolerable on demonstration of ALARP under the VOGA risk level action criteria. The following ALARP analysis provides assurance that all risk treatment options have been considered.					
Additional control considered		Assessment of option		Adopted/not adopted	
Refer to Section 6.2.7 for source control and oil spill response ALARP evaluation tables.					
Limit crude oil inventory in CGS		Limiting the inventory in the storage cells to reduce the potential impact in the event of a release from the CGS. If implemented, this measure would reduce the commercial viability of the operation as it would significantly reduce the production rates and may also increase the presence of a tanker in the field – with the associated risks which this would incur.		Not adopted	
Standby vessel in situ 24 hrs/day: To monitor the PSZ and be equipped with an automatic identification system to aid in its detection at sea, and radar to aid in the detection of approaching third-party vessels.		Reduces risk of vessel collision and subsequent unplanned release of hydrocarbons High cost associated with contracting standby vessel. Costs of operating navigational equipment. The costs associated with having a vessel on location 24/7 are considered disproportionate to the environmental benefit gained, particularly given the infrastructure are marked on charts and navigational aids are present.		Not adopted	
Strengthening of CGS shafts to increase impact resistance		Impact resistance of CGS shafts already meets relevant codes and standards. Upgrading CGS shafts to improve impact resistance was assessed as grossly disproportionate to risk benefit gained.		Not adopted	
RESIDUAL RISK AFTER ADDITIONAL CONTROLS:					
Consequence		Likelihood (of consequence)		Residual risk	
Catastrophic (5)		Rare (A)		Medium	
ACCEPTABLE LEVEL OF RISK DEMONSTRATED:					
Principles of ESD not compromised	External Context – objects or claims considered	Internal Context – VOGA HSE / procedures met	Other Requirements met	RR < High (RRII)	EPO(s) manage risk to acceptable level(s)
Relevant principles of ESD not compromised given proposed controls	N/A – no external objections or claims received	Yes – Risk managed in accordance with VOGA HSE policy and aligned to Performance Standards, Wandoo Marine Operations Manual [WNB-1000-YV-0001] and SPM Marine Facility Procedures [WPA-7000-YV-0002]. Potential spills to be managed in accordance with Wandoo Emergency Response Plan [VOG-2000-RD-0017]/Wandoo Field OSCP [WAN-2000-RD-0001].	Yes – vessels and facility navigation lighting comply with relevant regulations	Yes – RR = RRIII (Medium)	Yes, EPOs specify no uncontrolled release of hydrocarbons. The following relevant overarching EPOs (Section 3.4) maintained providing control measures maintained: EPO-OP-01; EPO-OP-03; EPO-OP-04; EPO-OP-05; EPO-OP-06; EPO-OP-07; EPO-OP-08; EPO-OP-09; EPO-OP-10; EPO-OP-11; EPO-OP-12; EPO-OP-13; EPO-OP-16; EPO-OP-17; EPO-OP-18; EPO-OP-19; EPO-OP-20

6.4.2 Description of hazard

6.4.2.1 Overview

The storage of hydrocarbons carries an inherent risk of spills, which needs to be managed. The hazard review identified the following credible causes of a release from the CGS:

- Degradation/collapse of the CGS shaft due to fatigue, corrosion of steel reinforcement, extreme storm;
- Impact from a colliding vessel; and
- Tanker station keeping failure.

This EP considers the worst-credible case to be a release from the largest cell (39,747m³) over a period of 24 hours. Refer to Section 3.2.1 for further details.

6.4.3 Impact assessment

6.4.3.1 Impact assessment criteria

Refer to Appendix 3 for the impact assessment criteria for a liquid hydrocarbon release.

6.4.3.2 Key findings from OSTM Report (Appendix 3)

Area of surface oil:

The maximum distance from the release location to the low (1-10 g/m²), moderate (10-50 g/m²) and high (>50 g/m²) exposure thresholds was 2,867 km west-northwest (winter), 2,186 km northwest (winter) and 921 km east-northeast (summer), respectively.

For spills commencing during summer, transitional and winter conditions, the following receptors recorded oil exposure on the sea surface (at the low threshold) at probabilities greater than 80% across all seasons: Ancient coastline at 125 m depth contour Key Ecological Feature (KEF) and the Northwest Shelf Integrated Marine and Coastal Regionalisation of Australia (IMCRA).

Length of shoreline contact:

The greatest length of shoreline contact at, or above, the low threshold (10 g/m²) during the summer, transitional and winter seasons was 553 km, 128 km and 110 km, respectively.

Volume of oil on shore:

The probability of oil contact to shorelines varied between seasons; summer (86%), transitional (37%) and winter (60%). The greatest volume of oil predicted to accumulate on the shorelines from a spill trajectory was 16,791 m³ for a spill commencing in the summer period.

Dissolved hydrocarbon exposure:

In the surface (0-10 m) depth layer, the greatest probabilities of dissolved hydrocarbon exposure (at the low threshold) across all seasons was predicted at the Northwest Shelf (IMCRA) with probabilities of 72%, 43% and 48%, in summer, transitional and winter periods, respectively. The Northwest Shelf IMCRA had recorded the greatest probabilities of exposure in the 10 – 20 m

depth layer (37% in summer, 26% in transitional periods and 22% in winter) and 20-30 m depth layer (15% in summer, 11% in transitional periods and 9% in winter).

Entrained hydrocarbon exposure:

In the surface (0-10 m) depth layer, the greatest probabilities of entrained hydrocarbon exposure (at the low threshold) across all seasons was predicted at the Continental slope demersal fish communities (KEF) with probabilities of 74%, 94% and 85% in summer, transitional and winter periods, respectively.

In the 10-20 m depth layer, the greatest probabilities of low entrained hydrocarbon exposure was predicted at the Northwest Shelf IMCRA (80% in summer and 43% in transitional and winter periods).

In the 20-30 m depth layer, Montebello Australian Marine Park recorded the greatest probability of entrained hydrocarbon exposure with probabilities of 10%, 28% and 20% in summer, transitional and winter periods, respectively.

6.4.3.3 Impacts to environmental sensitivities

The potential impacts associated with a crude oil release from the CGS without the use of oil spill response strategies such as chemical dispersion, are provided in Table 6-25.



Table 6-25: Summary of environmental impacts due to a release of Wandoo Crude from the CGS tank

Environmental sensitivity	Exposure mechanism	Impact	Consequence classification
Marine habitats			
Corals	Entrained/shoreline	<p>Significant coral reefs within the EMBA include Ningaloo Marine Park, the Montebello/Barrow/Lowendal islands, Shark Bay, Muiron Island, the Dampier Archipelago, Glomar Shoals, Rankin Bank, Mermaid Reef and the Rowley Shoals (Section 4.4.2.2 and Figure 4-3). Ningaloo Marine Park, the Montebello/Barrow/Lowendal islands, Muiron Island, the Dampier Archipelago, Glomar Shoals, Rankin Bank, Mermaid Reef and the Rowley Shoal also occurring within Hydrocarbon Area. No coral reef communities are found in the Operational Area. The nearest area of significant corals reef to the Operational Area being the Glomar Shoals (approximately 37km northeast) and Ningaloo Reef (approximately 250km away). Spill modelling (Appendix 3) predicts that in the event of a CGS spill:</p> <p>There are low probabilities of moderate levels of dissolved aromatic hydrocarbons reaching coral reef communities;</p> <p>High entrained hydrocarbon exposures within 0 to 20 m water depth layer are expected to reach Barrow Island, Montebello, and Ningaloo Marine Parks, Glomar Shoals KEF, Barrow Island MMA, Muiron Islands MMA, Ningaloo Marine Park and Rankin Bank.</p> <p>Moderate to high shoreline accumulation may occur at multiple shoreline receptors across all seasons modelled including Rowley Shoals (Clerke Reef, Imperieuse Reef), Lowendal Island, Barrow Island, Mermaid Reef, Muiron Islands, Rowley Shoals and Dirt Hartog Island.</p> <p>Direct contact with entrained or shoreline hydrocarbons could lead to chemical toxicity across cellular structure leading to coral bleaching and colony death. Instead of acute mortality, it is more likely that oil effects occur in sub-lethal forms, such as reduced photosynthesis, growth or reproduction (NOAA, 2014). Shoreline hydrocarbon contact is limited to intertidal corals which will be periodically exposed to surface hydrocarbons as well as planktonic stages of corals in particular during periods of coral spawning.</p> <p>Intertidal coral reefs also have the potential for smothering due to shoreline accumulation. As modelling outputs are an aggregate of all potential spill trajectories and therefore it is not credible that all receptors would be exposed at any one time. On this basis, impacts to these areas (including spawning) are likely to be limited and re-colonisation/recovery could be expected over time.</p> <p>In the event of a CGS spill there is a potential for hydrocarbon exposures to result in significant but recoverable (in >1 year) species or habitat damage.</p>	Major (4)



Environmental sensitivity	Exposure mechanism	Impact	Consequence classification
Seagrasses	Entrained/shoreline	<p>The EMBA include seagrass habitats located in waters surrounding Shark Bay, Ningaloo Reef, Dampier Archipelago and Montebello and Barrow islands (Section 4.4.2.3 and Figure 4-3). Within the Hydrocarbon Area Ningaloo Reef, Dampier Archipelago and Montebello and Barrow islands exist. No seagrasses are found within the Operational Area. Noting seagrass species within the EMBA exhibit seasonal trends in abundance and distribution, in response to natural disturbance events and Dugong grazing.</p> <p>Spill modelling (Appendix 3) predicts:</p> <p>Moderate levels of dissolved hydrocarbons are predicted to impact Montebello and Barrow Island seagrass habitats; and</p> <p>High entrained hydrocarbon exposures within 0 to 20 m water depth layer are expected to reach Montebello Islands Marine Park, Shark Bay, Barrow Island MMA and Ningaloo Marine Park.</p> <p>Moderate to high shoreline accumulation may occur at multiple shoreline receptors across all seasons modelled including Barrow Island, Christmas Island and Montebello Islands.</p> <p>Entrained and shoreline hydrocarbons may smother leaves of seagrass beds in shallow intertidal areas. Intertidal seagrass communities would theoretically be the most susceptible because the leaves and rhizomes may both be affected. When seagrass leaves are exposed to oil, sub-lethal quantities of the soluble fraction can be incorporated into the tissue, causing a reduction in tolerance to other stress factors (Zieman et al., 1984). The toxic components of petroleum oils are thought to be the PAH, which are lipophilic and therefore able to pass through lipid membranes and tend to accumulate in the thylakoid membranes of chloroplasts (Ren et al., 1994). In the event of a CGS spill there is a potential for hydrocarbon exposures to result in significant but recoverable species or habitat damage.</p>	Major (4)
Macroalgae	Entrained/shoreline	<p>Macroalgal habitat within the EMBA and Hydrocarbon Areas are widespread throughout shallower areas of the region, particularly where hard substrates occur. There are no specifically identified areas of significant environmental value (Section 4.4.2.4 and Figure 4-3).</p> <p>In the event of a CGS spill, macroalgae in intertidal areas have the potential to be exposed to in-water and shoreline hydrocarbons. Residues may be left in the area as the tide ebbs, but will be flushed with each flood tide. Studies have shown that macroalgae appear to recover rapidly from oiling, irrespective of the degree of impact and level of oiling. This is attributed to the fact that most of the new algae growth is produced near the base of the plant while distal parts (which would be exposed to the oil contamination) are continually lost (Connell and Miller, 1981).</p>	Moderate (3)



Environmental sensitivity	Exposure mechanism	Impact	Consequence classification
		<p>In the event of a CGS spill there is a potential for hydrocarbon exposures to intertidal areas where macroalgae may occur, to result in temporary and recoverable impacts to macro-algal habitats.</p>	
Mangroves	Shoreline	<p>The shoreline occurring within EMBA and shoreline Hydrocarbon Area includes mangrove habitats located along the Dampier Archipelago, Montebello Islands, Ningaloo coastline and scattered areas along the coast between Onslow and just north of Port Hedland (Section 4.4.3.1 and Figure 4-4). No mangrove communities are found within the Operational Area. The closest regionally significant mangroves to the Operational Area are those occurring within the Dampier Archipelago (greater than 30 km from Operational Area). With notable belts of mangroves occurring between Coral Bay (within shoreline Hydrocarbon Area and approximately 400km from Operational Area) and Eighty Mile Beach (approximately 300km away from Operational Area and within shoreline Hydrocarbon Area).</p> <p>Spill modelling (Appendix 3) predicts moderate to high shoreline accumulation may occur at Dampier Archipelago, Montebello Islands and the Ningaloo coastline.</p> <p>Observations by Lin and Mendelssohn (1996), demonstrated that more than 1kg/m² of oil during the growing season would be required to impact marsh or mangrove plants significantly. However, mangroves can take more than 30 years to recover from severe oil spill impacts (NOAA, 2014).</p> <p>Subsequently the impact is significant but recoverable species of habitat damage.</p>	Major (4)
Intertidal beaches/mudflats/rocky shorelines/intertidal reef platforms	Shoreline	<p>Intertidal beaches, mudflats, rocky shorelines and reef platforms are widespread throughout the EMBA (4.4.3.3). Three intertidal beach/mudflat areas of international conservation significance occur within the shoreline Hydrocarbon Area (Bandicoot Bay, Eighty Mile Beach and Roebuck Bay) (Section 4.4.3.3 and 4.4.3.4). Notable rocky shorelines and intertidal reef platform areas within the shoreline Hydrocarbon Area occur along the Ningaloo coast and North West Cape (Section 4.4.3.4). No beaches, mudflats, rocky shorelines and reef are within Operational Area.</p> <p>Spill modelling (Appendix 3) predicts that moderate to high shoreline accumulation may occur at Barrow Island (Bandicoot Bay), Eighty Mile Beach, Roebuck Bay, Ningaloo Marine Park and coastline of the North West Cape.</p> <p>Oil has the potential to interfere with infaunal organisms in these areas either by modifying the habitat or smothering the feeding respiratory and/or locomotory structures of these organisms.</p>	Minor (2)



Environmental sensitivity	Exposure mechanism	Impact	Consequence classification
		<p>Hydrocarbons may be left on the intertidal shores as the tide ebbs, but it would be expected that this would be flushed with each flood tide. Natural flushing is more likely to reduce impacts in exposed areas of shoreline.</p> <p>Subsequently the impact is short term localised disruption of ecosystem.</p>	
Sandy beaches	Shoreline	<p>The values associated with sandy beaches are assessed with regard to the following environmental sensitivities: marine reptiles, seabirds and other users (4.4.3.5). Refer to these sections for further detail.</p>	
Protected and threatened species			
Fish and sharks	Dissolved/ Entrained	<p>Fish and sharks are expected to be present within the EMBA, in-water Hydrocarbon Area and Operational Area however their presence is generally transient and sporadic (Etkin, 2003). Four species of shark, three sawfish and two rays listed as Threatened or Migratory under the EPBC Act potentially occur in the Operational Area. Seven shark, three sawfish and two ray species which are listed as Threatened or Migratory under the EPBC Act may potentially occur in the Hydrocarbon Area.</p> <p>Within the in-water Hydrocarbon Area, Ningaloo Reef is the main known aggregation area for whale sharks, waters off Exmouth is an identified aggregation area for grey nurse shark and endemic fish communities are found in water depths between 100 m to 300 m in Continental slope demersal fish communities and Western demersal slope KEFs (Section 4.4.4.4). Table 4-6 and Table 4-7 provides details of fish species or species habitat that may occur within the Project Areas.</p> <p>Studies indicate that the dissolved aromatic compounds (typically the mono-aromatic hydrocarbons and the two and three ring poly-aromatic hydrocarbons) are commonly the largest contributor to the toxicity of solutions generated by mixing oil into water (Di Toro et al., 2007).</p> <p>Fish and sharks most likely to be exposed to entrained and dissolved hydrocarbons are pelagic free-swimming fish and sharks as they dwell in the surface layers of the water column (<20 m depth). Some shark species, such as the whale shark, tend to feed close to the surface and may be exposed to the presence of entrained hydrocarbons. A foraging BIA for the whale shark was identified as intersecting with the EMBA, in-water Hydrocarbon Area and Operation Area. Whale sharks are known to routinely move between surface and to depths of >30 m, and in offshore regions can spend most of their time near the seafloor (DSEWPac 2011c). Nursing and foraging BIA for dwarf sawfish, freshwater sawfish and green sawfish was identified within EMBA. Demersal fish within the in-water Hydrocarbon Area are not expected to be impacted given the presence of in-water hydrocarbons is predicted in the surface layers (<20 m depth) only. Pelagic free-</p>	Minor (2)



Environmental sensitivity	Exposure mechanism	Impact	Consequence classification
		<p>swimming fish and sharks exposed to entrained hydrocarbons within the surface layers are unlikely to suffer long-term damage from oil spill exposure because in-water hydrocarbons are typically insufficient to cause harm (ITOPF 2011). Pelagic species are also generally highly mobile and as such are not likely to suffer extended exposure (e.g. >40–96 hours) at concentrations that would lead to chronic effects due to their patterns of movement, therefore fish and shark kills as a result of a spill in open water are unlikely.</p> <p>The larval stages of fish species are more likely to be susceptible; however, in comparison to predation and natural loss, any impacts would be over a small proportion of the marine environment in which they may occur and any measurable impact at the population level is likely to be low. In addition, fish mortality from oil spills is rarely reported and it is unlikely that significant population level impacts will occur.</p> <p>Consequently, the spill is only expected to cause a very localised disruption of behaviours/ecosystem.</p>	
Marine mammals	Dissolved/ Entrained	<p>Marine mammals may be present within the EMBA, Hydrocarbon Area and Operational Area during the Petroleum Activity and impacted by dissolved/ entrained hydrocarbons (Table 4-8). However, the presence of most species is expected to be of a transitory nature only, with a small number of species having an important behaviour (e.g. foraging, breeding) identified within the Hydrocarbon Area. Cetaceans listed as Threatened or Migratory under the EPBC Act may potentially occur in the EMBA and in-water Hydrocarbon Area (Section 4.4.4.5 and Table 4-8). The migration BIA for the humpback whale, and distribution BIA for the pygmy blue whale are located with the in-water Hydrocarbon Area and Operations Area. dolphins are also known to occur and transit through the EMBA and Hydrocarbon Area.</p> <p>Marine mammals can be exposed to oil externally (e.g. swimming through oil) or internally (e.g. swallowing the oil, consuming oil affected prey, or inhaling of volatile oil related compounds). Impacts from ingested oil and subsequent lethal or sub-lethal toxicity are possible; however, the susceptibility of cetaceans varies with feeding habits. Toothed whales and dolphins gulp feed at depth (and are therefore less likely to be exposed to entrained/dissolved oil given its presence in surface water layers (<20 m) only). While mammals do not appear to exhibit avoidance behaviours, as highly mobile species, in general it is very unlikely that these animals will be constantly exposed to concentrations of hydrocarbons for continuous durations (e.g. >48–96 hours) that would lead to chronic effects.</p> <p>Some whales, particularly those with coastal migration and reproduction, display strong site fidelity to specific resting, breeding and feeding habitats, as well as to their migratory paths. There are migratory and distribution BIAs identified for humpback whales and pygmy blue whales, respectively. Oil in biologically</p>	Major (4)



Environmental sensitivity	Exposure mechanism	Impact	Consequence classification
		<p>important habitats may disrupt natural behaviours, displace animals, reduce foraging or reproductive success rates and increase mortality.</p> <p>Dugongs may occur within EMBA and Hydrocarbon Area with Breeding, calving, nursing and foraging grounds within the Exmouth Gulf and North West Cape regions. Presence may occur throughout the year. Presence in Shark Bay BIAs may be more seasonal, between April and November. Shark Bay falling within the EMBA and shoreline Hydrocarbon Area. Dugongs may also ingest oil (directly, or indirectly via oil-affected seagrass), and depending on the amount and type of oil, the effects could be short-term to long-term/chronic (e.g. organ damage). However, it is noted that reports on oil pollution damage to dugongs is rare (ITOPF 2014).</p> <p>Entrained and dissolved oil components may persist for periods of time; however, the duration of exposure is still expected to be limited.</p> <p>Given the predominantly transient nature of any presence of marine mammals within the in-water Hydrocarbon Area, any impact that did occur would be at an individual and not a population level for any receptor group. For those species where aggregations may occur (e.g. in BIAs), they are typically seasonal. Recovery of any impacted water column associated receptors is expected to occur.</p> <p>Given that the area of potential impact is relatively small in relation to the offshore environment, and cetaceans and other marine mammals would be transitory, any interface with in-water hydrocarbons is unlikely to cause an impact to significant numbers. However, there is potential for exposure to individual cetaceans and other protected fauna species, hence the impact is classified as major.</p>	
	Surface	<p>Marine mammals may be present within the EMBA, Hydrocarbon Area and Operational Area during the Petroleum Activity and impacted by surface hydrocarbons (Table 4-8).</p> <p>Modelling also predicts that moderate and high surface hydrocarbon exposures have the potential to extend across the EMBA including the migration and distribution BIAs for the humpback whale and pygmy blue whale, respectively. It is possible for whales to be exposed to surface hydrocarbons if the hydrocarbon release occurs during the migration period. Marine mammals are also likely to encounter surface oil as they return to the surface to breathe and baleen whales feed by surface skimming. However, short-term inhalation of petroleum vapours or ingestion of surface hydrocarbons at concentrations similar to those found in oceanic spills may not be detrimental either in terms of structural tissue damage or respiratory gas exchange. Cetaceans are smooth skinned hairless mammals, so oil tends not to stick to their skin since they do not rely on fur for insulation, hence they will not be sensitive to the physical effects of oiling.</p>	Major (4)



Environmental sensitivity	Exposure mechanism	Impact	Consequence classification
		<p>Given that the area of potential impact is relatively small in relation to the offshore environment, and cetaceans and other marine mammals would be transitory, any interface with hydrocarbons is unlikely to cause an impact to significant numbers. However, there is potential for exposure to individual cetaceans and other protected fauna species, hence the impact is classified as major.</p>	
	Shoreline	<p>Marine mammals are expected to be present within the EMBA and Hydrocarbon Area shoreline during the Petroleum Activity (Table 4-8). Shorelines do not occur within Operational Area.</p> <p>Oiling of pinnipeds (seals and sea lions) can cause removal of natural water repellent oils from their fur making them less buoyant and susceptible to hypothermia (Kucklick, 1997). However, given that oil will be significantly weathered and dispersed by the time it reaches the pinniped habitats, it is unlikely to result in significant exposure to a large population.</p> <p>The highest potential risks for dugongs are related to direct ingestion of seagrass or macroalgae exposed to acute or chronic toxicity and or drastic reduction on seagrass coverage due to hydrocarbon spills (Heinsohn et al., 1977). However, as explained for these receptors, impacts are unlikely to be extensive and are recoverable.</p> <p>Given that oil will be significantly weathered and dispersed by the time it reaches the pinniped or dugong habitats, any interface with hydrocarbons is unlikely to cause an impact to significant numbers. However, there is potential for exposure to individual protected fauna species, hence the impact is classified as major.</p>	Major (4)
Marine reptiles (turtles and sea snakes)	Surface	<p>Marine turtles may be present within the EMBA, Hydrocarbon Area and Operational Area during the Petroleum Activity and impacted by surface hydrocarbons (Table 4-10). The presence of most marine reptile species within the Hydrocarbon Area and Operational Area are expected to be of a transitory nature only.</p> <p>Species of sea snakes and marine turtles are known to occur in the Hydrocarbon Area.</p> <p>There are a number of BIAs for turtle species (flatback, green, hawksbill, loggerhead) that occur within the Hydrocarbon Area (Table 4-11). An interesting flatback turtle BIAs exist within Operational Area, based around nesting locations within the Dampier Archipelago (30km from Operational Area) however flatback, green, hawksbill, loggerhead may occur in transit.</p> <p>Two species of sea snake listed as Protected may occur in the EMBA; Short-nosed Sea snake and Leaf-scaled Sea snake. The short-nosed sea snake may occur within the Operational Area however prefers the reef flats or shallow waters along outer reef edges in water depths to 10 m and generally stay within 50 m of the reef.</p>	Major (4)



Environmental sensitivity	Exposure mechanism	Impact	Consequence classification
		<p>The leaf-scaled sea snake occurs on the reefs of the with Sahul Shelf in Western Australia, particularly on Ashmore and Hibernia Reefs within the EMBA.</p> <p>Spill modelling results predicts zones of high and moderate surface hydrocarbon exposures in these areas in the event of a CGS spill (Appendix 3). Marine reptiles are likely to come in contact with oil in the event of a spill as they surface to breathe. Marine turtles can be exposed to oil externally (e.g. swimming through oil slicks) or internally (e.g. swallowing the oil, consuming oil affected prey, or inhaling of volatile oil related compounds). Several aspects of turtle biology and behaviour place them at particular risk, including a lack of avoidance (NOAA 2010b) and large pre-dive inhalations (Milton and Lutz 2003). Harmful effects may occur through ingestion of oil, inhalation of toxic vapours (e.g. close to the spill source) or irritation to the head, neck and flippers due to oil contact with the skin. Within the immediate vicinity of the spill event, where hydrocarbons are still fresh, this could lead to fatal impacts on individuals. No confirmed reports of impacts to marine wildlife were received or surveyed during the Montara oil spill scientific monitoring studies (UniQuest 2010). Given the presence of marine reptiles in the Hydrocarbon Area are expected to be transitory, the exposure of marine reptiles to surface hydrocarbons is unlikely to have a population effect.</p> <p>Subsequently the potential impact is single fatalities of protected species; hence the impact is classified as major.</p>	
	Shoreline	<p>Marine turtles and sea snakes may be present within the EMBA and Hydrocarbon Area shorelines during the Petroleum Activity and impacted by shoreline hydrocarbons (Table 4-11). The Hydrocarbon Area contains shoreline habitats critical to the survival of marine turtles where genetic stocks are present (Section 4.4.4.6). Critical shoreline habitats for marine turtles within the Hydrocarbon Area are listed in Table 4-10.</p> <p>Spill modelling results indicate that moderate to high shoreline accumulation may occur at nesting locations critical to the survival of marine turtles (Appendix 3). Shallow water habitats key to nesting and inter-nesting sites occur within Dampier Archipelago, Ningaloo Reef and offshore islands (e.g. Barrow Island, Montebello Islands) occur within Hydrocarbon Area (Table 4-12).</p> <p>In the unlikely event that hydrocarbons did accumulate at a turtle nesting area, there is potential for adult turtles and/or hatchlings to be impacted within Hydrocarbon Areas. Potential impacts include smothering of adults and hatchling and/ or avoidance behaviour of adult turtles. This could result in failed or aborted nesting attempts or a reduction in survival rates of hatchlings.</p> <p>As many turtle species do not nest exclusively within a single area, and as all of these areas would not be impacted for this scenario, the impact is unlikely to affect the viability of the species, but may result in a</p>	Major (4)



Environmental sensitivity	Exposure mechanism	Impact	Consequence classification
		<p>significant but recoverable impact to the population if hatchlings over a season are impacted. Sea snakes occurring on reef systems within shoreline Hydrocarbon Area may be impacted. As there is a potential for more than a single protected species fatality the impact is classified as Major.</p>	
Birds	Surface	<p>There are multiple species (or species habitat) of birds that may occur within the EMBA, Hydrocarbon Area and Operational Area (The wedge-tailed shearwater is a migratory visitor to WA and may occur within the EMBA and Hydrocarbon Area (Table 4-4). Estimates indicate more than one million shearwaters migrate to the Pilbara islands each year (DBCA 2017). The wedge-tailed shearwater will excavate burrows on vegetated islands for nesting. Known breeding locations in the North-west Marine Region. Breeding locations within the Hydrocarbon Area include Forestier Island (Sable Island), Bedout Island, Dampier Archipelago, Passage Island, Lowendal Island, islands off Barrow Island (Mushroom, Double and Boodie Islands), islands in the Onslow area (including Airlie, Bessieres, Serrurier, North and South Muiron and Locker Islands) (DEWHA 2008a) Breeding locations within the broader EMBA are inclusive of those with Hydrocarbon Area as well as islands in the Freycinet Estuary, and south Shark Bay (Slope, Friday, Lefebvre, Charlie, Freycinet, Double and Baudin Islands) (DEWHA 2008a).</p> <p>The fairy, lesser crested and roseate terns may have both a resident sub-population and a migratory population present in the Pilbara (DBCA 2017). These tern species nest in open areas, typically sand scrapes/depressions on the sandy beaches of offshore islands. Within the EMBA these tern species are known to nest within the region of the Ningaloo Marine Park, Muiron and Sunday islands (CALM 2005). The Montebello Islands support the largest breeding population of roseate terns in WA (DEWHA 2008). Ningaloo Marine Park, Muiron and Sunday islands, and Montebello Islands occur within the Hydrocarbon Area.</p> <p>Caspian terns, little terns, and ospreys have also been known to breed on Serrurier Island and neighbouring inshore islands (DEWHA 2008) within the Hydrocarbon Area.</p> <p>Bedout Island (offshore from Port Hedland and within the Hydrocarbon Area) supports one of the largest colonies of brown booby in WA (Figure 4-9); the masked booby, lesser frigatebird, roseate tern and common noddy also breed in the area (DEWHA 2008).</p> <p>Tropicbird species spend most of their lives at sea, typically found in tropical and subtropical seas around northern Australia. A small sand cay at Bedwell Island, within Clerke Reef in Rowley Shoals Marine Park, is one of very few breeding areas in Western Australia for the Red-tailed tropicbird. Both locations occurring within the Hydrocarbon Area (Table 4-4). The presence of most species, particularly within the Operational Area, are expected to be of a transitory nature only.</p>	Major (4)



Environmental sensitivity	Exposure mechanism	Impact	Consequence classification
		<p>A number of threatened and migratory birds may occur in parts of the EMBA where moderate and high surface hydrocarbons are predicted (Section 4.4.4.3 and Appendix 3) and include areas with recognised offshore foraging BIAs for seabird species listed in Table 4-5.</p> <p>Scholten et al., 1996 indicates that a layer of 25µm thick would be harmful to birds that contact the slick. Estimates for the minimal thickness of oil that will result in harm to seabirds through ingestion from preening of contaminated feathers, or the loss of thermal protection of their feathers, has been estimated at 10µm (French, 2009) to 25µm (Koops et al., 2004).</p> <p>Oil spills can have a variety of effects including fouling of the plumage, ingestion of oil, effects on reproduction and physical disturbance. Many of the species that occur offshore are surface-feeding or plunge-diving pelagic birds, so that oil slicks would potentially interfere with feeding and increase exposure risk.</p> <p>Seabirds are expected to be present within parts of the EMBA where moderate and high surface hydrocarbons are predicted but their presence is expected to be transient. Hence population level impacts are unlikely, but mortality of protected seabirds may occur.</p>	
	Shoreline	<p>Bird species (or habitat) may occur within the EMBA and Hydrocarbon Area shoreline areas (Table 4-4). The presence of most species are expected to be of a transitory nature only. Shorelines do not occur within Operational Area.</p> <p>A number of threatened and migratory birds may occur within the shoreline Hydrocarbon Area. The Hydrocarbon Area contains recognised onshore breeding and resting BIAs for seabird species listed in Table 4-5. Important seabird breeding sites within the region include the Montebello/Barrow islands group, Rowley Shoals, Eighty Mile Beach and Roebuck Bay. All areas are within the EMBA and Hydrocarbon Area (Section 4.4.4.3).</p> <p>Given these shorelines provide habitat for a range of species, a large number of seabird mortalities may potentially occur if an oil spill reaches these areas during critical periods. Given all areas will not be impacted, the impacts are not likely to affect species viability, the impact is classified as Major.</p>	Major (4)
Socio-economic receptors			
Commonwealth and State Managed	Surface/entrained	There are a number of Commonwealth and State fisheries with management areas that intersect the EMBA and Hydrocarbon Area (Section 4.5.1.1, 4.5.1.2). Commonwealth managed fisheries (Table 4-15) and State managed (Table 4-16) may be a relevant receptor to aspects of the activity occurring within the Operational	Moderate (3)



Environmental sensitivity	Exposure mechanism	Impact	Consequence classification
Fisheries and Aquaculture		<p>Area; however it is unlikely that fishing activity will occur in the Operational Area due to the restricted zones. No Aquaculture projects exist within Operational Area. Within the EMBA, the low threshold for floating oil and shoreline contact has potential for some socioeconomic impacts (NOPSEMA 2019), however these impacts are expected to be temporary.</p> <p>In the event of a significant oil spill, surface oil is less likely to result in direct impacts to the fish but may interfere with fishing operations through damage to vessels and fishing gear, exclusion to areas during clean-up operations and any follow-up monitoring and surveillance activities. There is also a potential that perceptions of fish tainting due to the spill could indirectly result in economic impacts to the fishery.</p> <p>Fish species themselves, are more likely to be impacted by in-water hydrocarbons as they dwell in the water column. Refer also to impact assessments for related receptors, including fish and sharks.</p> <p>Tainting is a change in the characteristic smell or flavour of fish and may be due to oil being taken up by the tissues or contaminating the surface catch (McIntyre et al 1982). Taint in seafood renders it unfit for human consumption or unsellable due to public perception. Tainting may not be a permanent condition but will persist if the organisms are continuously exposed; but when exposure is terminated, depuration will quickly occur (McIntyre et al 1982).</p> <p>A major oil spill may result in the temporary closure of part of fishery management areas. It is unlikely that a complete fishery would be closed due to their large spatial extents, but the partial closure may still displace fishing effort. Given all areas will not be impacted, the impacts are expected to be limited to temporary closures, the impact is classified as moderate.</p>	
Commercial Shipping	Surface	<p>Commercial shipping may be a relevant receptor to aspects of the activity occurring within the EMBA, Hydrocarbon Area and Operational Area during the Petroleum Activity. The Operational Area is approximately 25km from the northbound shipping fairway from Dampier (Figure 4-21). There are significant commercial shipping activities within the EMBA and Hydrocarbon Area (4.5.2). The impact on shipping in the event of a CGS spill is potential modification of shipping routes to avoid the area affected.</p> <p>Given all areas will not be impacted and impacts are expected to be limited to temporary exclusion of area affected, the impact is classified as minor.</p>	Minor (2)
Other users	Surface	<p>A number of tourist destinations occur within the EMBA and Hydrocarbon Area, and include the Ningaloo Coast (Section 4.5.4.2). However, none occur within Operational Area. Within the EMBA, the low threshold for floating oil and shoreline contact has potential for some socioeconomic impacts (NOPSEMA 2019),</p>	Moderate (3)



Environmental sensitivity	Exposure mechanism	Impact	Consequence classification
		<p>however these impacts are expected to be temporary. In the event of a CGS spill, there is the potential for temporary changes to socio-economic users occurring within the EMBA. Depending on the fate and trajectory of the oil, tourism activities which could have a temporary impact to the tourism industry. As persistent hydrocarbons are likely to dissipate from the environment over time, and as the volumes ashore suggest remediation may be difficult or expensive, impacts are expected to be extensive but temporary.</p> <p>More broadly in the region, the impacts to humans and the activities themselves are not likely to be significant; however, there is the potential for temporary closure of recreational activities, including diving, for risk to public health and safety. This would be short term and limited to the area immediately affected by a spill. There is a possibility of impacts to tourism operators due to actual or perceived impacts to aesthetics and the regional marine resources by the general public through negative media attention.</p> <p>Any closures would be short term in nature, as entrained hydrocarbons will naturally disperse, and any shoreline accumulation would breakdown due to natural weathering processes. As such, potential impacts are considered to be extensive but temporary.</p>	
Protected areas			
World Heritage Areas	Surface/ shoreline/ entrained	The Ningaloo Coast WHA and Shark Bay WHA occur within the EMBA (Section 4.6.1) may be impacted in the event of a CGS spill. However, the Hydrocarbon Area only encompasses Ningaloo Coast WHA. The values associated with Ningaloo Coast WHA and Shark Bay WHA has been assessed in terms of the protected/threatened species and marine habitat and socioeconomic receptor sections outlined above.	As above
Australian Marine Parks	Surface/ shoreline/ entrained	Australian Marine Parks located within the EMBA and Hydrocarbon Area are listed in Table 4-23. There are no Australian Marine Parks within the Operational Area. The values associated with Australian Marine Parks have been assessed in terms of the protected/threatened species and marine habitat and socio-economic receptor sections outlined above.	As above
State Marine Protected Area	Surface/ shoreline/ entrained	State Marine Reserves located within the EMBA and Hydrocarbon Area are listed in Table 4-25. There are no State Marine Protected Area within the Operational Area. The values associated with State Marine protected areas have been assessed in terms of the protected/threatened species and marine habitat and socio-economic receptor sections outlined above.	As above



Environmental sensitivity	Exposure mechanism	Impact	Consequence classification
Ramsar Wetlands	Surface/ shoreline/ entrained	Eighty-mile beach Ramsar site is located within the EMBA and Hydrocarbon Area (Section 4.6.7). The values associated with Eighty-mile beach Ramsar site has been assessed in terms of the protected/threatened species and marine habitat and socio-economic receptor sections outlined above.	As above
Key ecological features			
Ancient coastline at 125m depth contour	No exposure	The EMBA and Hydrocarbon Area overlaps the Ancient coastline at 125 m depth contour KEF. However, modelling of in-water hydrocarbons was predicted to be limited to surface water depths of 0 to 20 m (Appendix 3). Subsequently there will be no hydrocarbon exposure to the seabed values of this KEF.	No exposure
Canyons linking the Cuvier Abyssal Plain and the Cape Range Peninsula	Entrained	The EMBA and Hydrocarbon Area overlaps the Canyons linking the Cuvier Abyssal Plain and the Cape Range Peninsula KEF. However, modelling of in-water hydrocarbons was predicted to be limited to surface water depths of 0 to 20 m (Appendix 3). Subsequently there will be no hydrocarbon exposure to the sub-bottom habitat values of this KEF. There is potential for marine mammals, reptiles and seabirds transiting the KEF to be exposed moderate levels of entrained hydrocarbons. Potential impacts of Wandoo Crude on marine mammals, reptiles and seabirds are outlined above.	Moderate (3)
Commonwealth Waters adjacent to Ningaloo Reef	Surface	The EMBA and Hydrocarbon Area overlaps the Commonwealth Waters adjacent to Ningaloo Reef KEF. There is potential for intertidal reefs in the area to be exposed to moderate levels of entrained and shoreline hydrocarbons. Potential impacts of Wandoo Crude on corals are outlined above. There is potential for marine mammals, reptiles and seabirds transiting the area to be exposed to moderate levels of entrained and surface hydrocarbons. Potential impacts of Wandoo Crude on marine mammals, reptiles and seabirds are outlined above.	Moderate (3)
Continental slope demersal fish communities	Surface	The EMBA and Hydrocarbon Area overlaps the continental slope demersal fish communities KEF. Demersal fish communities associated with this KEF are found in water depths between 100 to 300 m (Section 4.4.4.4). Modelling of in-water hydrocarbons was predicted to be limited to surface water depths of 0 to 20 m (Appendix 3). Subsequently there will be no hydrocarbon exposure to the demersal fish communities values of this KEF. However commercial fishing operations within the area may be affected by exclusion zones in the event of a spill. Potential impacts of Wandoo Crude on commercial fisheries are outlined above.	Moderate (3)



Environmental sensitivity	Exposure mechanism	Impact	Consequence classification
Western demersal slope	No exposure	The Western demersal slope KEF occurs within the EMBA but is not located in the Hydrocarbon Area. The values of this KEF are not exposed to levels of hydrocarbons that will illicit an impact.	No exposure
Exmouth Plateau	No exposure	The EMBA and Hydrocarbon Area overlaps the Exmouth Plateau. The Exmouth Plateau lies at water depth of approximately 500 m to more than 5,000 m Modelling of in-water hydrocarbons was predicted to be limited to surface water depths of 0 to 20 m (Appendix 3). There will be no exposure to Wandoo Crude at these depths. Subsequently there will be no hydrocarbon exposure to the seabed values of this KEF.	No exposure
Glomar Shoals	Surface	The Glomar Shoals KEF lies within the EMBA and Hydrocarbon Area Modelling of in-water hydrocarbons was predicted to be limited to surface water depths of 0 to 20 m (Appendix 3). The Glomar Shoals are a submerged littoral feature in water depths of 33 – 77 m. Subsequently there will be no hydrocarbon exposure to the values of this KEF. However commercial fishing operations within the area may be affected by exclusion zones in the event of a spill. Potential impacts of Wandoo Crude on commercial fisheries are outlined above.	Moderate (3)
Mermaid Reef and Commonwealth Waters surrounding Rowley Shoals	Surface	Mermaid Reef and Commonwealth Waters surrounding Rowley Shoals KEF is located within the EMBA and Hydrocarbon Area. There is potential for intertidal reefs in the area to be exposed to moderate levels of entrained and surface hydrocarbons. There is potential for marine mammals, reptiles and seabirds transiting the area to be exposed to zones of low and medium sea surface exposure. Potential impacts of Wandoo Crude on marine mammals, reptiles and seabirds are outlined above.	Major (4)
Wallaby Saddle	No exposure	Wallaby Saddle is an area of seafloor in 4,000 m to 4,700 m water depths located within the EMBA but outside of the Hydrocarbon Area. Modelling of in-water hydrocarbons was predicted to be limited to surface water depths of 0 to 20m (Appendix 3). There will be no exposure to Wandoo Crude at these depths.	No exposure
Ancient coastline at 90m to 120m depth	No exposure	The Ancient coastline at 90 m to 120 m depth is located within the EMBA but outside of the Hydrocarbon Area, hence there will be no hydrocarbon exposure to values of this KEF that will illicit potential ecological impacts.	No exposure



Environmental sensitivity	Exposure mechanism	Impact	Consequence classification
Commonwealth marine environment surrounding Houtman Abrolhos Islands	No exposure	The Commonwealth marine environment surrounding Houtman Abrolhos Islands KEF lies within the EMBA but outside of the Hydrocarbon Area, hence there will be no hydrocarbon exposure to values of this KEF that will illicit potential ecological impacts.	No exposure
Perth Canyon and adjacent shelf break and other west coast canyons	No exposure	The Perth Canyon and adjacent shelf break and other west coast canyons KEF lies within the EMBA but outside of the Hydrocarbon Area, hence there will be no hydrocarbon exposure to values of this KEF that will illicit potential ecological impacts.	No exposure
Western rock lobster	No exposure	The Western rock lobster KEF lies within the EMBA but outside of the Hydrocarbon Area, hence there will be no hydrocarbon exposure to values of this KEF that will illicit potential ecological impacts.	No exposure
Commonwealth marine environment adjacent to the west coast inshore lagoons	No exposure	The Commonwealth marine environment adjacent to the west coast inshore lagoons KEF lies within the EMBA but outside of the Hydrocarbon Area, hence there will be no hydrocarbon exposure to values of this KEF that will illicit potential ecological impacts.	No exposure
Ashmore Reef and Cartier Island	No exposure	The Ashmore Reef and Cartier Island surrounding Commonwealth waters lies within the EMBA but outside of the Hydrocarbon Area (Section 4.5.5.16), hence there will be no hydrocarbon exposure to values of this KEF that will illicit potential ecological impacts.	No exposure
Canyons linking Argo Abyssal Plain with Scott Plateau	No exposure	The Canyons linking Argo Abyssal Plain with Scott Plateau KEF lies within the EMBA but outside of the Hydrocarbon Area, hence there will be no hydrocarbon exposure to values of this KEF that will illicit potential ecological impacts.	No exposure

VERMILION OIL & GAS AUSTRALIA

Title: Wandoo Facility Environment Plan
Number: WPA-7000-YH-0007
Revision: 16
Date: 21 April 2021



Environmental sensitivity	Exposure mechanism	Impact	Consequence classification
Seringapatam Reef and Commonwealth waters of the Scott Reef Complex	No exposure	The Seringapatam Reef and Commonwealth waters of the Scott Reef Complex lies within the EMBA but outside of the Hydrocarbon Area hence there will be no hydrocarbon exposure to values of this KEF that will illicit potential ecological impacts.	No exposure

6.4.4 Catastrophic Environmental Event identification

As discussed in Sections 6.4.2 and 6.4.3 catastrophic impacts could result from a complete and sudden loss of containment of crude oil from a CGS storage cell (39,747m³).

The identified CEE is therefore designated as CEE-03 – Crude oil spill from CGS.

6.4.5 Critical Controls identification

In accordance with the process described in Section 5.4.2 all controls for CEE-03 – Crude oil spill from CGS have been assessed for criticality. This assessment has resulted in a concise listing of identified Critical Controls as provided in Table 6-26.

Table 6-26: CEE-03 Critical Controls

Hazard	Activity/Cause/Mitigation	Critical Control
CEE-03 Crude oil spill from CGS	Degradation/collapse of CGS shaft due to fatigue, corrosion of steel reinforcement, extreme storm etc.	Structures (Super- and Substructures)
		Structural Integrity Manual
		Change Management
	Passing vessel collision with Platform.	Emergency communications.
		Navigation aids.
	Attending vessel collision with Platform.	Structures (Super- and Substructures)
	Tanker station keeping failure.	CALM Buoy mooring System
		Static tow
		SPM Marine Facilities Procedures Manual
	Mitigation	Wandoo Emergency Response Plan [VOG-2000-RD-0017]/Wandoo Field OSCP [WAN-2000-RD-0001]/CGS Source Control Plan [VOG-3000-YH-0001].

6.4.6 Mitigation measures

6.4.6.1 Source Control

The CGS Source Control Plan [VOG-3000-YH-0001] provides a response framework to implement to minimise the volume of oil spill originating from CGS. The response is under the Wandoo ERP [VOG-2000-RD-0017] and runs in parallel to the oil spill ICT.

The plan provides a description of the following leak source control options to manage a major or catastrophic failure of one of the CGS storage compartments resulting in oil spill to sea:

- Containment of crude by ballast pump operations;
- Containment of crude by transfer between compartments;
- Export/discharge of crude from WNB;
- Containment of crude via temporary/permanent repair.
- Subsea intervention by ROV /Divers.

Figure 6-5 presents a flowchart identifying the three most likely situations that could result from a catastrophic damage to a compartment on WNB and the objectives for each situation.

Seven objectives have been identified for source control from a damaged compartment. The plan provides decision trees for each likely situation and a task checklist for each identified objective.

CGS source control resource requirements and ALARP assessment are detailed in Table 6-27.

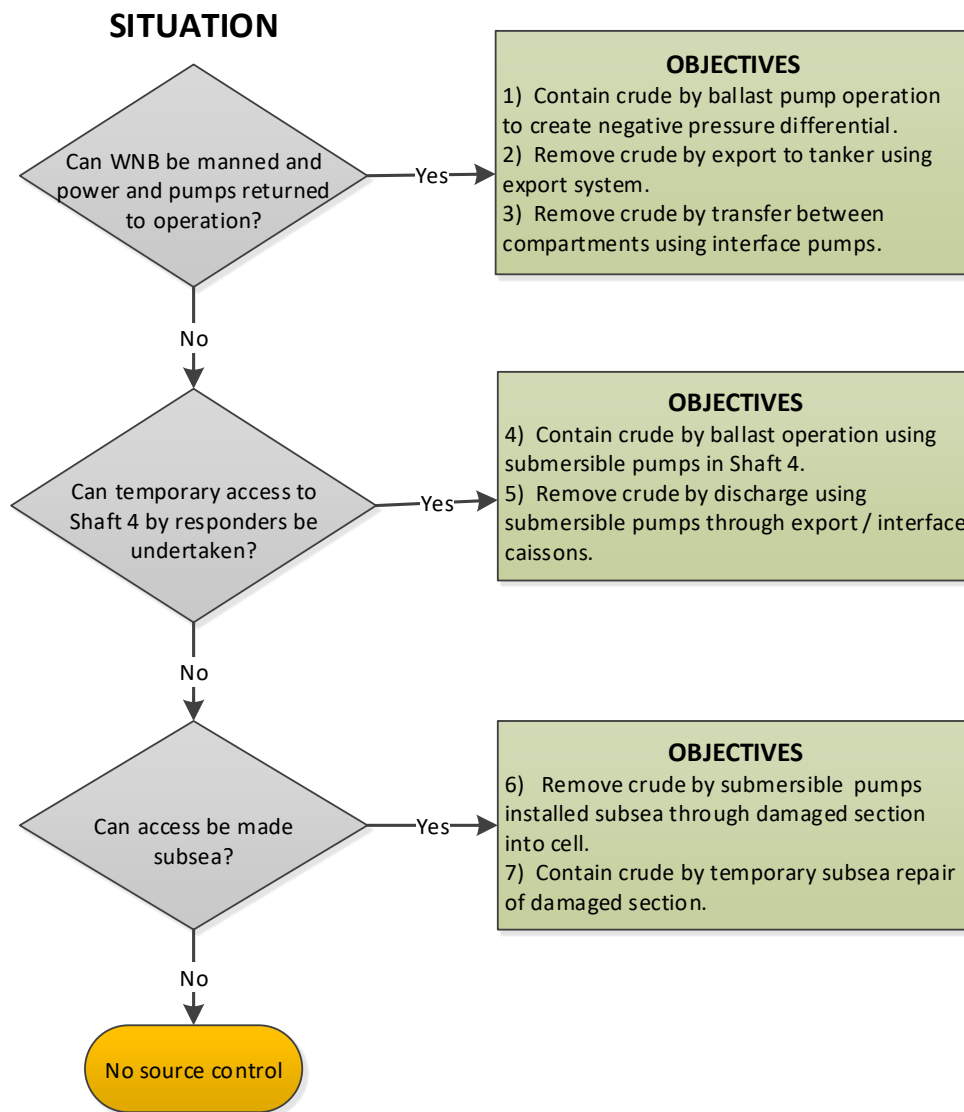

Figure 6-5 CGS source control situations and objectives flowchart

6.4.6.2 Oil spill response

Sections 6.5 and 7.10 summarise the process undertaken to mitigate the hazard scenarios described and assessed in Sections 6.4.2 and 6.4.3 respectively. To support a hazard based approach to planning, oil spill scenarios outlined in this EP were grouped into spill categories based on fluid type, duration, and volume. The spill category which covers this hazard is ‘F’.

The hazards impacts and the controls required to manage the environmental impact of the oil spill response strategies are outlined in Section 6.5. The impacts of the response strategies were considered in the strategy selection process.

6.4.7 Risk Ranking

6.4.7.1 Consequence

The worst-case consequence is based on the precautionary assumption that the entire contents of the largest storage cell is released over a period of 24 hrs. Whilst this failure scenario is pessimistic in the absence of detailed structural failure analysis it was deemed appropriately conservative.

Whilst none of the individual impacts detailed in Section 6.4.3 are ranked above Major (4) the cumulative impacts has been assessed as having Catastrophic (5) potential.

6.4.7.2 Likelihood

The likelihood of event was assessed as 'Rare' (A) on the Vermilion qualitative risk matrix. Basis for the rating is:

- The frequency of a passing vessel collision with the Facility is 3.3×10^{-4} per year (Ref 5153649-SA-REP-001). The probability of the vessel being sufficiently large and the impact to be in such a location to result in a hydrocarbon release from the CGS would be significantly less frequent (at least an order of magnitude). This is because the only credible scenario for CGS release is where the impact energy with topsides/shaft is sufficient to cause collapse of the topsides and where the topsides then collapse down onto the CGS roof in such a way as to significantly damage to the CGS. Therefore, the likelihood of this event resulting in a worst-case environmental impact is assessed as rare;
- The frequency of a manoeuvring vessel (i.e. vessels attending the platform) collision with WNB is 2.87×10^{-4} per year (Ref 5153649-SA-REP-001); however, manoeuvring vessels do not have sufficient energy to result in total platform collapse and therefore, loss of containment from the CGS is not credible for these impact types; and
- Other causes of structural failure are in the 'Rare' (A) region. This rating is based on:
 - Extreme weather exceeding design strength (storm return period of 2×10^{-4}) has similar probability to passing vessel collision; however, similar assumptions apply with regards to the likelihood of a direct impact by such storm events and the likelihood that topsides would collapse onto the CGS causing damage to the CGS roof. Accordingly, these events are also assessed as Rare(A).
 - Likelihood of seismic events exceeding design strength is $<1 \times 10^{-4}$ (Ref AF4001-WNB-RH-0053) and so these events are also assessed as Rare (A).

6.4.7.3 Residual Risk Ranking

Based on Vermilion risk matrix and criteria (see Table 5-1), utilising the consequence (5, catastrophic) and Likelihood (A, Rare) of this event, the residual risk level for this environmental hazard is assessed to be Medium (RRII).

6.4.8 ALARP demonstration

6.4.8.1 Overview

The risk associated with a release of hydrocarbon from the CGS is inherent to the design of this Facility however these risks can be managed through the implementation of effective control measures and associated performance monitoring. The ALARP assessment has concluded that the risks are being managed to ALARP because:

- There are sufficient layers of protection in place for the current risk level; and
- Additional controls and alternative arrangements were not considered to be practical due to the associated increase to other risks.

6.4.8.2 Existing controls

The hazard summary in Section 6.4 describes the controls for this hazard. The range of controls includes multiple independent layers of protection, including:

- WNB structure Basis of Design includes weather criteria, corrosion allowance, impact energy, and fatigue life;
- The WNA and WNB structure is covered under the Asset Integrity Management System to ensure that the assets are fit for service. The asset integrity system monitors the condition of the asset and coupled with asset life extension processes, ensure there is an understanding of the status of the asset to minimise the likelihood of structural collapse;
- Marine Operations Manual [WNB-1000-YV-0001] specifies management controls over vessel activities, including specification of safe operating window;
- Collisions from tanker and vessel activities in the field are managed through a combination of administrative and engineering controls to reduce the likelihood of a collision event;
- Navigation aids and communication equipment to allow the Facility to contact vessels and alert them to the Facility's presence; and
- CGS Source Control Plan (VOG-3000-YH-0001).

The feasibility of installing and using AIS (Automatic identification system) on the Wandoo facilities is currently being assessed.

6.4.8.3 Source control

The management of resources, information and communications via the implementation of established procedures is absolutely essential for effective emergency response in order to ensure protection of life, property and the environment.

The CGS Source Control Contingency Plan [WNB-3000-PD-0007] provides a guideline to the required response. VOGA ensures that the CGS Control Contingency Plan resources are reviewed and managed to enable the lowest reasonably practical response duration as part of the Oil Spill Capability Review process.

CGS source control resource requirements and ALARP assessment are detailed in Table 6-27.



Table 6-27 CGS source control resource requirements and ALARP review

Tactic to achieve the objective	Applicability	Resource requirement
Contain crude by ballast pump operation to maintain negative pressure differential	Applicable in a situation where WNB be can be manned and power and pumps returned to operation. Control leak source via reducing pressure in compartment to below hydrostatic pressure to create ingress of seawater to compartments.	Existing WNB personnel and operational equipment only required
Remove crude by export to taker using export system	Applicable in a situation where WNB be can be manned and power and pumps returned to operation. If export system is operational. Remove crude from damaged compartment (s).	Tanker of opportunity onsite (within 2 to 10 days)
Remove crude by transfer between compartments using interface pumps	Applicable in a situation where WNB be can be manned and power and pumps returned to operation. If interface pumps are operational. Control leak source via transferring crude from damaged compartment to undamaged compartment.	ROV onsite (within 3 days) MSA in place with Intervention Engineering (Perth based), various other ROV providers are historically readily available at short notice from Perth.
<u>Subsea Pumping and/or Temporary Repair:</u> -Contain crude by ballast operation using submersible pumps in Shaft 4 -Remove crude by discharge using submersible pumps through export/ interface caissons	Applicable when WNB cannot be manned and power and pumps not operational. These tactics can be utilised when temporary access to shaft 4 by responders can be undertaken, or access can be made subsea.	Structural and subsea engineers (within 2 to 5 days) MSA's in place with SEA Subsea Engineers; (Perth) GHD Concrete Consultants (Perth) ROV onsite (within 3 days): MSA in place with Intervention Engineering (Perth based), various other ROV providers are historically readily available at short notice from Perth.



Tactic to achieve the objective	Applicability	Resource requirement
<p>-Remove crude by submersible pumps installed subsea through damaged section into cell</p> <p>-Contain crude by temporary subsea repair of damaged section</p>		<p>Salvage company onsite (within 5 to 10 days): Salvage companies from Singapore (SMIT and Ardent) would be contracted rapidly via BIMCO charter (a draft agreement is in place with Ardent to enable rapid mobilisation).</p> <p>Submersible pumps onsite (within 5 to 10 days): MSA in place with NPE Pumps (Perth)</p> <p>Divers (if applicable) (within 3 to 5 Days): MSA in place with Shelf Diving (WA Based DSV)</p> <p>2 x Vessels: Use of supply vessel, ROV /dive contractor vessel and/or vessels of opportunity</p>
Improvements considered	Assessment of option	Adopted/not adopted
<p>Establishment of an MSA with a salvage company.</p>	<p>Salvage Industry prepared for unplanned events and have a 24/7 capability that is able to respond via a PO at time of event. A draft agreement was put in place in 2019 with Ardent Salvage to ensure rapid mobilisation..</p>	<p>Not adopted</p>
<p>Undertake a review of pump capacities and the use of a generator to power WNB as an alternative strategy..:</p>	<p>Improvement to standby documentation to ensure guidance on response options and identified resources are current.</p>	<p>Adopted</p> <p>This will be reviewed during the next CGS SSCP revision (2021)</p>



6.4.8.4 Spill response

Overall assessment

The response strategies to reduce the environmental impact are from this hazard scenario are outlined 6.4.6 and are implemented through the Wandoo Field OSCP [WAN-2000-RD-0001]. VOGA has a spill preparedness planning process that identifies suitable spill response strategies which:

- Is consistent with the hazard profile;
- VOGA's response strategies and procedures to reduce the volume of hydrocarbons spilt and reduce the environmental impact are outlined in the Wandoo Field OSCP [WAN-2000-RD-0001]. These response strategies are consistent with those outlined in the National Plan;
- Considers the benefits of each strategy as outlined in Sections 6.4.6; and
- Considers the risks and impacts of each strategy as outlined in Section 6.5.

The spill response planning process is described in Section 7.10 and results in spill response which will best mitigate the environmental impacts of this hazard scenario.

Section 7.10.4 outlines the process to plan and review response arrangements requirements to support managing spill risks to ALARP. The Alarp demonstration for spill response is provided in Section 6.2.8.4.

Dispersant Application

As part of the submission of the five-yearly revision in 2021 a review of dispersant application was conducted to ensure dispersant response arrangements matched the revised trajectory modelling and associated impact and risk assessment.

The review of the dispersant arrangements initially considered all aspects of dispersant response preparedness for the CGS spill scenario and identified the following items for further assessment:

- dispersant application rates, utilising trajectory modelling results to determine rate of application requirements based on surface oil;
- timeframe for dispersant application, interrogating the trajectory modelling data to understand applying dispersant earlier reduces the impact of an oil spill and noting impact weathering has on dispersant efficacy (see Table 6-30); and
- review of Table 6-8 against the CGS dispersant needs assessment to determine if changes are required to this assessment.

To support dispersant needs assessment, the following oil spill trajectory modelling runs were identified and analysed:

- Minimum time to shoreline contact;
- Quickest time for floating oil to reach an open water location where dispersant cannot be applied (e.g. Montebello Australian Marine Park);
- Longest length of shoreline contact; and
- Largest volume of oil ashore.

For each run, the following data was utilised:

- Total area of floating oil on the sea surface between $>50 \text{ g/m}^2$ and $<100 \text{ g/m}^2$ after 6, 12, 18, and 24 hours after the initial release and on day 2, 5, 10, 20 and 30;
- Total area of floating oil on the sea surface $>100 \text{ g/m}^2$ after 6, 12, 18, and 24 hours after the initial release and on day 2, 5, 10, 20 and 30.

Analysis of the trajectory modelling data has shown that in general the dispersant needs for a worst-case CGS release during the first few days of a response can be delivered by the dispersant capability described in the OPEP. Summary of the trajectory modelling data used for this analysis is provided in Section 3.5 of Appendix 3.

The modelling results highlighted the following situations where dispersant needs exceeded the arrangements outlined in the OPEP:

- It is possible that surface oil could occur within a no-go zone, the Montebello Islands Australian Marine Park (AMP), and be unable to be dispersed prior to aerial dispersion resources arriving on site in 30 hours for Category D and F spills..

An analysis of all scenarios modelled for the CGS spill identified one scenario having oil move in a westerly direction out of the dispersant application zone towards the Montebello AMP and sensitive receptors, occurring at the 29 hour timestamp (Refer to Appendix 3). Therefore, on the remote likelihood the spill scenario eventuates there is a less than 1% chance that the spill will result in oil being outside of the application zone and unable to be dispersed. For the tanker scenario, there was a 4% likelihood that oil moved out of the dispersant application zone towards the Montebello AMP within 30 hours (the fastest being at 23 hours post spill) and impacted sensitive receptors (Refer to Section 6.3.3.3).

For these circumstances, although they are highly unlikely, a vessel dispersant capability for application within 24 hours would mitigate the likelihood and extent of shoreline contact.

For the scenarios where the quantity of surface oil exceeded arrangements the exceedance occurs in the first 24hrs; after which dispersant need is below 77 m^3 (Refer to Section 3.5 of Appendix 3). Due to operational and logistical constraints, applying aerial dispersant within 24hrs is unable to be guaranteed, even if standby arrangements were in place. The current capability described in the OPEP, aerial dispersion can guarantee to begin within 30 hours. The constraints to guaranteeing full application rates within 24hrs of oil release include the following, with an ALARP assessment documented in Table 6-8.:

- Time of the spill relative to daylight hours as dispersant cannot be sprayed at night;
- The requirement to confirm dispersant efficacy in open water prior to initiating a full-scale dispersant response given the variability in the fate and weathering of oil;
- The location of the oil relative to its release location, the coast, the facility, and response resources resulting in uncontrollable variability in commencing dispersant spraying as early as possible;
- Time to safely establish full capacity dispersant transfer stations at airport.

Note these operational constraints only apply to a scenario where there is a hazardous event causing instantaneous oil release due to the catastrophic structural failure of the CGS. In all other (and more probable) CGS failure scenarios, particularly those that take longer than 24-30hrs for oil to start being released from the CGS, once the structural failure event has materialised (e.g.

ship collision) aerial and marine dispersant capability arrangements would be deployed to be on standby for activation pending oil release.

The review identified that:

- Dispersant application rates were within the OPEP assumptions of 77m³ /day after 24 hours, meaning that if dispersant application were to commence after 24 hours, then the dispersant application capacity in the OPEP would be sufficient to disperse all surface oil. The review considered surface area of oil with surface oil thickness of >50 g/m², reflecting the thickness where dispersant is known to be effective and would therefore be targeted during a response (Refer to Section 3.5 of Appendix 3).
- The likelihood of an Oil Tanker Cell or CGS oil spill following the fastest time to the nearest sensitivity and being unable to be dispersed by aerial means within the available timeframe of 30 hours is very low (1% for CGS spill and 4% for Oil Tanker Cell spill)
- Whilst full capacity of resources offered through the FWADC is not needed after the first 24 - 30hrs, the VOGA ERP Logistics Management Plan [VOG-7000-RH-0008] will be revised to include deployment of all six of contracted aircraft as part of activation of Oil Pollution Plan 2.
- A recommendation to review marine dispersant application was made and additional arrangements put in place to enable dispersant to be applied within 24 hours (Refer Table 6-8).

6.4.8.5 *Additional control and alternative arrangements*

VOGA carried out an assessment of alternative arrangements and additional controls to reduce risks. These include:

- Limiting the inventory in the storage cells to reduce the potential impact in the event of a release from the CGS. If implemented, this measure would reduce the commercial viability of the operation as it would significantly reduce the production rates and may also increase the presence of a tanker in the field – with the associated risks which this would incur.

6.4.8.6 *Conclusion*

The ALARP assessment has concluded that the risks are being managed to ALARP because:

- There are sufficient layers of protection in place for the current risk level; and
- In the unlikely event of spill from the CGS, response strategies which match the hazard profile are defined in the Wandoo Field OSCP [WAN-2000-RD-0001] and will be implemented to reduce the impact of the spill to the environment. The resources to implement the response has been determined and evaluated to ensure that the response strategies can be achieved.

6.4.9 **Acceptability demonstration**

These risks are considered to be acceptable due to:

- There are sufficient layers of protection in place to manage the vessel and tanker activities within the Wandoo Field;
- The controls in place resulting in an extremely low frequency of this event;



- Ongoing stakeholder consultation undertaken for this Wandoo Facility EP did not generate any feedback regarding concerns due to spills from the hydrocarbon containment system (CGS);
- With the preventative and mitigative controls in place, the conservation of biological diversity and ecological integrity shall be maintained; and
- In the event of a hydrocarbon spill, the activities, and the proposed performance management measures, meet the requirements of internal VOGA procedures that have been developed in accordance with relevant environmental legislation.

6.5 Environmental impacts of oil spill response

6.5.1 Hazard report

Table 6-28: Hazard report – Environmental impacts of oil spill response

HAZARD: Environmental impact from oil spill response activities						
EP risk number:		EP-OP-R04				
Potential impacts:		Increased entrained fraction of hydrocarbons in the water column after adding dispersants. Toxicity effects on marine fauna from dispersant. Disturbance to benthic habitat, adjacent vegetation and other environmentally sensitive areas. Scouring of sediments. Waste generation, disposal and management.				
PREVENTION:						
Activity/cause	Existing control measures	Control type	Control hierarchy	Performance outcome	Performance standard	Measurement criteria
Key component as outlined WAN-WNAB-CP-ER-03-01 - <i>Response strategy - Monitor and evaluate.</i>	Ensure the most effective response strategies are being applied and environmental impact of the spill and response strategies are measured.	Administrative	Reduction	To mitigate the environmental impacts as a result of oil spill response activities.	Performance criteria, as per WAN-WNAB-CP-ER-03-01 - Response strategy - Monitor and evaluate	Assurance activities, as per WAN-WNAB-CP-ER-03-01 - Response strategy - Monitor and evaluate.
Key component as WAN-WNAB-CP-ER-03-02 - <i>Response Strategy - Chemical dispersant application.</i>	Application of chemical dispersant in accordance with the dispersant application zones.	Administrative	Reduction	Minimise environmental impacts associated with dispersant application.	Performance criteria, as per WAN-WNAB-CP-ER-03-02 - Response Strategy - Chemical dispersant application	Assurance activities, as per WAN-WNAB-CP-ER-03-02 - Response Strategy - Chemical dispersant application.
Key component as outlined WAN-WNAB-CP-ER-03-03 - <i>Response strategy - Mechanical dispersant application.</i>	Application of mechanical dispersant activities in accordance with application zones.	Administrative	Reduction	Minimise environmental impacts associated with mechanical dispersant activities.	Performance criteria, as per WAN-WNAB-CP-ER-03-03 - Response strategy - Mechanical dispersant application	Assurance activities, as per WAN-WNAB-CP-ER-03-03 - Response strategy - Mechanical dispersant application.
Key component as outlined in WAN-WNAB-CP-ER-03-04 - <i>Response strategy - Containment and recovery.</i>	Deployment of equipment will be undertaken by trained incident response personnel.	Administrative	Reduction	Minimise environmental impacts associated with improperly deployed equipment.	Performance criteria, as per WAN-WNAB-CP-ER-03-04 - Response strategy - Containment and recovery	Assurance activities, as per WAN-WNAB-CP-ER-03-04 - Response strategy - Containment and recovery.
Key component as outlined in WAN-WNAB-CP-ER-03-05 - <i>Response strategy - Protection and deflection.</i>	Deployment of equipment will be undertaken by trained incident response personnel.	Administrative	Reduction	Minimise environmental impacts associated with improperly deployed equipment.	Performance criteria, as per WAN-WNAB-CP-ER-03-05 - Response strategy - Protection and deflection	Assurance activities, as per WAN-WNAB-CP-ER-03-05 - Response strategy - Protection and deflection.
	Booms shall only be installed after consultation and approval from the Department of Transport.	Administrative	Reduction	Minimise impact to fauna from oil spill response activities.	Performance criteria, as per WAN-WNAB-CP-ER-03-05 - Response strategy - Protection and deflection	Assurance activities, as per WAN-WNAB-CP-ER-03-05 - Response strategy - Protection and deflection.
Key component as outlined WAN-WNAB-CP-ER-03-06 - <i>Response strategy - Shoreline clean-up.</i>	Shoreline assessments will be used to select appropriate shoreline clean-up techniques.	Administrative	Reduction	Minimise impact to key shoreline habitats associated with shoreline clean-up activities.	Performance criteria, as per WAN-WNAB-CP-ER-03-06 - Response strategy - Shoreline clean-up	Assurance activities, as per WAN-WNAB-CP-ER-03-06 - Response strategy - Shoreline clean-up.
Key component as outlined in WAN-WNAB-CP-ER-03-07 - <i>Response strategy - Oiled wildlife response.</i>	Induction and training for onshore and offshore teams.	Administrative	Reduction	Minimise potential impacts on fauna caused by oiled wildlife response activities.	Performance criteria, as per WAN-WNAB-CP-ER-03-07 - Response strategy - Oiled wildlife response	Assurance activities, as per WAN-WNAB-CP-ER-03-07 - Response strategy - Oiled wildlife response.



Activity/cause	Existing control measures	Control type	Control hierarchy	Performance outcome	Performance standard	Measurement criteria
Key component as outlined in WAN-WNAB-CP-ER-01-05 - <i>Arrangements are accessible.</i>	Current oil spill response arrangements are accessible to all personnel in the event of an oil spill.	Administrative	Reduction	To mitigate the environmental impacts as a result of oil spill response.	Performance criteria, as per WAN-WNAB-CP-ER-01-04 - Arrangements are accessible	Assurance activities, as per WAN-WNAB-CP-ER-01-04 - Arrangements are accessible.
Key component as outlined in WAN-WNAB-CP-ER-01-06 - <i>Arrangements are understood.</i>	Oil spill response personnel understand and competently perform their response roles.	Administrative	Reduction	To mitigate the environmental impacts as a result of oil spill response.	Performance criteria, as per WAN-WNAB-CP-ER-01-05 - Arrangements are understood	Assurance activities, as per WAN-WNAB-CP-ER-01-05 - Arrangements are understood.

MITIGATION:

Existing control measures	Control type	Control hierarchy	Performance outcome	Performance standard	Measurement criteria
Environmental monitoring of impact of the spill and response strategies.	Administrative	Mitigation	To assess environmental impacts associated with oil spill response activities which are outlined in the Wandoo Field OSCP [WAN-2000-RD-0001].	The Wandoo Field OSCP [WAN-2000-RD-0001] contains an environmental monitoring plan which considers: <ul style="list-style-type: none"> environmental impact associated with the spill and response strategies; environmental sensitivities to be monitored; monitoring methods and type; sources of baseline data; resources required and mobilisation times; and termination criteria. 	Results from environmental monitoring plan are available for IAP.

INITIAL RISK WITH EXISTING CONTROLS:

Consequence	Likelihood (of consequence)	Initial risk
Moderate (3)	Unlikely (B)	Medium

ADDITIONAL CONTROLS/DEMONSTRATION OF ALARP - VOGA WORKSHOP:

A medium risk is defined as tolerable on demonstration of ALARP under the VOGA risk level action criteria. The following ALARP analysis provides assurance that all risk treatment options have been considered.

Additional control considered	Assessment of option	Adopted/not adopted
Refer to Section 6.2.7 for source control and oil spill response ALARP evaluation tables.		

RESIDUAL RISK AFTER ADDITIONAL CONTROLS:

Consequence	Likelihood (of consequence)	Residual risk
Moderate (3)	Unlikely (B)	Medium

ACCEPTABLE LEVEL OF RISK DEMONSTRATED:

Principles of ESD not compromised	External Context – objects or claims considered	Internal Context – VOGA HSE / procedures met	Other Requirements met	RR < High (RRII)	EPO(s) manage risk to acceptable level(s)
Relevant principles of ESD not compromised given proposed controls	N/A – no external objections or claims received	Yes – Risk managed in accordance with VOGA HSE policy. Potential spills to be managed in accordance with Wandoo Emergency Response Plan [VOG-2000-RD-0017]/Wandoo Field OSCP [WAN-2000-RD-0001].	Yes – Wandoo Field OSCP [WAN-2000-RD-0001] consistent with NatPlan.	Yes – RR = RRIII (Medium)	Yes – EPOs specify mitigation or minimisation of potential environmental impacts via the application of specific performance criteria. The following relevant overarching EPOs (Section 3.4) maintained providing control measures maintained: EPO-OP-01; EPO-OP-03; EPO-OP-04; EPO-OP-05; EPO-OP-06; EPO-OP-07; EPO-OP-08; EPO-OP-09; EPO-OP-10; EPO-OP-11; EPO-OP-12; EPO-OP-13; EPO-OP-16; EPO-OP-17; EPO-OP-18; EPO-OP-19; EPO-OP-20

6.5.2 Description of hazard

While spill response activities are intended to reduce the potential environmental consequences of a hydrocarbon spill, response activities could potentially exacerbate or cause further environmental harm. Decisions regarding spill response activities need to consider both the potential environmental impacts associated with taking no action and the potential environmental impacts associated with a response activity or combination of spill response activities. Poorly planned and coordinated response activities can result in a lack of, or inadequate information and poor decisions being made during incident response.

Response activities can result in:

- Spreading of hydrocarbons further beyond the zone of contamination (e.g. secondary contamination due to hull contamination of response vessels);
- Inadequate surveillance leading to poor information and unforeseen impacts; or
- Inappropriate response strategy implemented, and additional sensitive receptors impacted (e.g. use of dispersants when containment and recovery would have been of greater benefit).

This section assesses the available spill response strategies to determine which strategies will be implemented in response to a diesel or crude oil spill.

The risk assessment of each response strategy considers the advantages and disadvantages of the different spill response options to determine if there would be a net environmental benefit resulting from the implementation of a particular response. The assessment considers the hydrocarbon type, threshold levels and sensitivity of the area potentially affected by the spill, and the potential outcomes (positive and negative) of the proposed response strategy.

This assessment has been undertaken based on predicted information to determine the level of spill response required. In the actual event of a spill, a SIMA is revisited regularly as more information becomes available on actual conditions, spill trajectory path and locations of sensitive receptors. This review process allows response strategies to be adjusted to provide optimal results.

6.5.2.1 Credible spill scenarios

Credible scenarios presented in Table 6-29 are based on oil spill hazards in this Wandoo Facility EPs, and grouped into 'Spill Categories' according to the following criterion:

- Type of hydrocarbon;
- Instantaneous or ongoing spill;
- Volume; and
- Amenability to similar spill response strategies.

Table 6-29: Summary of credible spill response strategies

Spill category	Wandoo Field EP Risk Element No.	Possible cause	Credible upper spill volume	Product type	VOGA ERP level	National Plan level
A	EP-OP-R02, EP-OP-R17 and EP-OP-R22	Surface spill	300m ³	Wandoo Crude	Level 1/2/3	2
B	EP-OP-R05	Bunkering spill	700m ³	Diesel	Level 1/2/3	1
C	EP-OP-R02	Ship bunker tank spill	1,300m ³	HFO	Level 2/3	2
D	EP-OP-R02	Oil tanker cell spill	10,000m ³	Wandoo Crude	Level 3	3
E	EP-OP-R01	Production well blowout continuous over 78 days	4,364m ³	Wandoo Crude	Level 3	3
F	EP-OP-R03	CGS spill	250,000bbl (39,747m ³)	Wandoo Crude	Level 3	3

6.5.2.2 Oil spill trajectory modelling

Key conclusions drawn from OSTM are used as the basis for planning response to each spill scenario. Although OSTM has inherent limitations, this information has been used in the response planning phase and will be used in an actual incident to assist in the environmental impact assessment (SIMA) of response strategies as a basis from which to begin the IAP process.

Methodology and outputs of the OSTM are provided in Appendix 3.

6.5.3 Impact assessment

The acceptability of the potential environmental impacts and risks associated with the following oil spill response strategies have been evaluated in accordance with VOGA's management systems and Regulations 13(5) and 13(6) of the OPGGS(E)R:

- Source control;
- Monitor and evaluate;
- Chemical dispersion;
- Containment and recovery;
- Mechanical dispersion;
- Protection and deflection;
- Shoreline clean-up;
- Oiled wildlife response.

6.5.3.1 Source control

Description of hazard

Source control activities are effective in minimising the quantity of hydrocarbons lost to the environment and reducing the area of potential exposure.

Potential source control activities include:

- Emergency shutdown;
- Isolation of equipment; and
- Drilling a relief well.

Impact assessment

Source control activities such as emergency shut down and isolation of equipment will reduce the volume of oil released to the marine environment. Consequently, these response strategies will not create additional impacts on the marine environment over and above the spill itself.

Drilling a relief well may be required if there is a total loss of well control. The response process to be followed in the event of a loss of well control incident is outlined in the Wandoo Field Source Control Contingency Plan [WNB-3000-PD-0007]. If a relief well was required, it would be drilled using a semi-submersible or jack-up MODU located within the Permit Area. The impacts associated with drilling a relief well are detailed in the Well Construction EP [WPA-7000-YH-0001].

6.5.3.2 Monitor and evaluate

Description of hazard

As discussed above, several methods can be used to monitor and evaluate, including:

- Surveillance from field infrastructure, MODU and vessels;
- Aerial surveillance;
- Satellite tracking buoys; and
- OSTM.

Many monitoring and evaluation methods will not create any additional impacts on the environment. However, surveillance of spill size and tracking its movement using vessels and aircraft will have an impact.

Potential impacts

There are a number of generic impacts that will arise (or could potentially arise) from vessel and aircraft operation. The nature of these additional routine impacts (e.g. discharges, emissions, vessel movements) and unplanned impacts (e.g. diesel spills) are as described within the following EP sections:

- Diesel spill to sea (Section 6.6);
- Noise (Section 6.11);
- Atmospheric emissions (Section 6.12);

- Artificial light (Section 6.13);
- Deck drainage and bilge water discharge (Section 6.15);
- Discharge of sewage, grey water and putrescible waste from vessels (Section 6.16);
- Non-hazardous and hazardous wastes (Section 6.9);
- Ancillary hydrocarbon or chemical spills/discharges (Section 6.20);
- Physical presence (Section 6.21); and
- Invasive marine pests (Section 6.8).

6.5.3.3 Chemical dispersion

Description of hazard

Chemical dispersion involves the application of chemical dispersant. VOGA has identified a dispersant application zone described in the Wandoo Field OSCP [WAN-2000-RD-0001] and shown in Figure 6-6 of this EP.

Dispersant efficacy testing

Dispersant efficacy testing was undertaken by ChemCentre (2015) to determine the efficacy profile of dispersants. Tests were conducted on fresh and weathered Wandoo Crude for their dispersibility with five different dispersants, including:

- Ardrox;
- Corexit 9500A;
- Dasic Slickgone EW;
- Dasic Slickgone NS; and
- Finasol OSR 52.

Weathering of Wandoo crude was tested under both summer and winter weather conditions. As summer exhibited greater weathering, crude weathered in these conditions were used for the dispersant efficacy laboratory tests.

Results from this study informed of the efficacy of a larger range of dispersants and if prolonged chemical dispersant application is viable on the Wandoo crude.

All the dispersants tested were effective at dispersing a large percentage of the oil on the water up to three days after the spill (Table 6-30). For each dispersant, '10A' represents the percentage of the weathered oil that has dispersed through the water column after ten minutes of agitation and considered to be an effective measure of dispersibility.

Table 6-30 Dispersant trial against the Wandoo crude, ChemCentre (2015)

Dispersant	Ardrox	Corexit 9500A	Finasol OSR 52	Slickgone EW	Slickgone NS
Oil	10A	10A	10A	10A	10A
Fresh	86%	100%	100%	100%	100%
1 day weathered	72%	79%	78%	100%	100%
2 day weathered	82%	84%	63%	100%	100%
3 day weathered	89%	100%	100%	100%	100%
4 day weathered	49%	66%	78%	100%	93%
5 day weathered	25%	54%	98%	39%	5%
10 day weathered	13%	35%	31%	23%	-

Note: AMSA accepts a dispersant on to the Oil Spill Control Register if it has a dispersant efficacy of 70%. VOGA modelled a conservative oil spill dispersant efficacy of 50%.

The dispersant trials gave particularly good results for all dispersants if used in the first three days. Of note was the increase in efficacy observed in most samples on a 3-day weathered sample over a 2-day weathered sample. While some variability in results might be expected, three of the dispersants had increased efficacy after three days, while the remaining two (Slickgone NS and Slickgone EW) were already giving 100% dispersant efficacy. While this result might suggest that spill responders dealing with a 2-day old slick might choose to wait a day to improve their response, this is not recommended due to the difficulty in ensuring that lab trials match the exact weathering conditions of a real spill.

Impact assessment

The application of chemical dispersant is highly effective in assisting the natural process of biodegradation and minimising the risk of oil impacts to vulnerable coastal receptors in the EMBA.

For some species/habitats, the use of chemical dispersants can effectively reduce the severity of hydrocarbon impact. Dispersing oil into the water column reduces the quantity of oil on the surface, subsequently reducing the amount of oil that can strand and smother any resource which it comes into contact with, i.e. mangrove pneumatophores (rhizomes that grow upwards vertically out of the mud – used for respiration and salt balance) and species such as turtles, migratory birds, seabirds and shorebirds. However, species present within the water column such as whales, dugongs, dolphins and sharks, and biological processes such as coral spawning, could be negatively affected by the increased concentration of dispersed oil and associated chemicals in the water column.

The use of dispersant has the potential to change both the rate and location of organism exposure to the oil. As dispersant causes the transfer of oil from the water surface into the water column, it introduces the need to assess this relative to the risk of exposure from oil remaining at the surface with the risk of exposure to the oil-dispersant mixture in the water column.

Potential impacts from the use of chemical dispersants include:

- Increased toxicity to marine habitats and fauna due, to the addition of dispersant chemicals to the marine environment; and
- Increased toxicity to marine habitats and fauna due to dispersed oil in the water column in the form of entrained oil and dissolved oil.

The decision to use chemical dispersants, as with all response strategies, is governed by the outcomes of a SIMA. In this case, a SIMA will consider the benefit of reducing the volume of floating oil against the potential impacts of increasing the volume of subsurface oil and the introduction of the chemical dispersant itself.

The use of chemical dispersant has potential environmental impacts which are associated with its inherent toxicity. Dispersants currently in use however are much less toxic than early-generation dispersants and the oil itself, with acute toxicity values (measured in standard 96h LC50 tests) typically in the range of 190 to 500 mg/L (Fingas, 2008). This was supported in recent studies of a range of dispersants, completed for the USEPA during the Macondo spill response. These studies showed that dispersants alone have only low toxicity, while dispersant-oil mixtures generally have similar toxicity to crude oil alone (Hemmer et al., 2011) <http://www.epa.gov/bpspill/dispersants-qanda.html#q011>

The potential impacts of chemical dispersant on key environmental sensitivities are outlined in Table 6-31, Table 6-32 and Table 6-33.

Some recent studies have indicated that Corexit 9500A oil mixtures may have significantly higher toxicity in the laboratory than either the dispersant or oil alone (Rico-Martínez et al., 2013; Radniecki et al., 2013; Zhang et al., 2013). However, it is suggested that this is due to an increase in organism exposure to oil within the water column following dispersant treatment, rather than an actual increase in toxicity (Coelho et al., 2013; Radniecki et al., 2013).

Embryonic and larval stages appear to be more sensitive than adults to both dispersants and dispersed oil (Clark et al., 2001), with LC50s for both oyster and fish larvae reported to be as low as 3 mg/L for dispersant alone. However, some studies report higher larval toxicity values (i.e. lower sensitivity) for dispersant that are closer to the adult values (Coutou et al., 2001).

Any dispersant used would be selected from the AMSA OSCA Register prior to use. Criteria for inclusion on the OSCA Register includes a ban on toxic components including benzene, carbon tetrachloride or other chlorinated hydrocarbons, phenols, cresols, caustic alkali, or free mineral acid.

The main source of toxicity from the application of dispersant to oil is likely to come from oil dispersed in the water column in the form of entrained oil or dissolved oil (i.e. the water accommodated fraction which can then potentially contact marine flora and fauna and benthic habitats).

A review of oil spill dispersants by Fingas (2008) confirmed that dispersant toxicity is consistently less than the toxicity of dispersed oil. Dispersant acute toxicity values are typically in the range of 190 to 500 mg/l (NAS, 2005). About half of these found that the cause for this was the increased PAHs, typically about 5 to 10 times, in the water column. PAHs are of particular environmental concern since they are carcinogenic and mutagenic to marine organisms and can persist in the environment for long periods (as opposed to more volatile aromatic hydrocarbons such as BTEX).

There is a low risk of toxicity to marine organisms from direct contact or ingestion of entrained Wandoo Crude, due to the low proportion of aromatic hydrocarbons present (APASA, 2013).

The elevated levels of hydrocarbons and subsequent impacts due to dispersant application are limited to the upper layers of the water column (ITOPF, 2014; Lee et al., 2013; European Maritime Safety Agency, 2010; APASA, 2013). During testing for the Montara spill, APASA (2010) found that effects associated with dispersed oil were mostly contained within the top metre of the water column, with the concentration quickly reducing with time, depth and distance from the application site. APASA (2013) further concluded that the concentration of hydrocarbons within the water column, due to dispersed oil, was low relative to the amount that was already in the water column from the release. Lee et al. (2013) also found that dispersed oil is rapidly entrained within the top 1m of the water column and within 24 hours the dispersed oil is likely to mix within the top 10m of the water column and be rapidly diluted.

The results of dispersant application modelling for Scenario 1 (refer Section 3.2 for methodology and Appendix 3 for modelling outputs) support these findings and demonstrated the following:

- Significant and consistent reduction in surface oil and maximum and average shoreline oil volumes compared to not using dispersant,
- Minor inconsistent increases (includes some decreases) in the 0-10m depth of in water oil concentrations compared to not using dispersant

Dispersant application modelling for Scenario 2 (CGS spill) was not undertaken given the instantaneous nature of the spill however the following has been used as a basis for the determination of a net environmental benefit, with negligible potential impacts on submerged sensitive receptors:

- Surface dispersant application is intended to treat floating hydrocarbons, thereby reducing the risk of air breathing marine fauna from becoming oiled. It also has the potential to reduce/eliminate contamination of sensitive intertidal habitats such as mangroves, coral reefs, and sandy shores by a reduction in shoreline oil loadings. A significant reduction in shoreline loadings has been demonstrated by modelling for a lower amount of dispersed oil (Scenario 1) and it is considered likely to result in shoreline oil reduction for the CGS scenario. Dispersant literature indicates that elevated levels of hydrocarbons and subsequent impacts due to dispersant application are limited to the upper layers of the water column, generally the first 10m, and are rapidly diluted through vertical and horizontal mixing (ITOPF, 2014; Lee et al., 2013; European Maritime Safety Agency, 2010; APASA, 2013). Submerged sensitive receptors in the vicinity of Wandoo are generally at depths greater than 10m and therefore unlikely to be directly contacted by elevated levels of entrained oil.
- The Dispersant Application Zone in place (Figure 6-6) is based on criteria that exclude dispersant being applied in the vicinity of submerged sensitive receptors. This ensures that any elevated levels of entrained oil do not have the potential to impact on any aggregations of marine life in the upper water column associated with these receptors.

The impacts of dispersants, oil dispersed in the water column and oil on key environmental sensitivities is detailed in Table 6-31, Table 6-32 and Table 6-33.

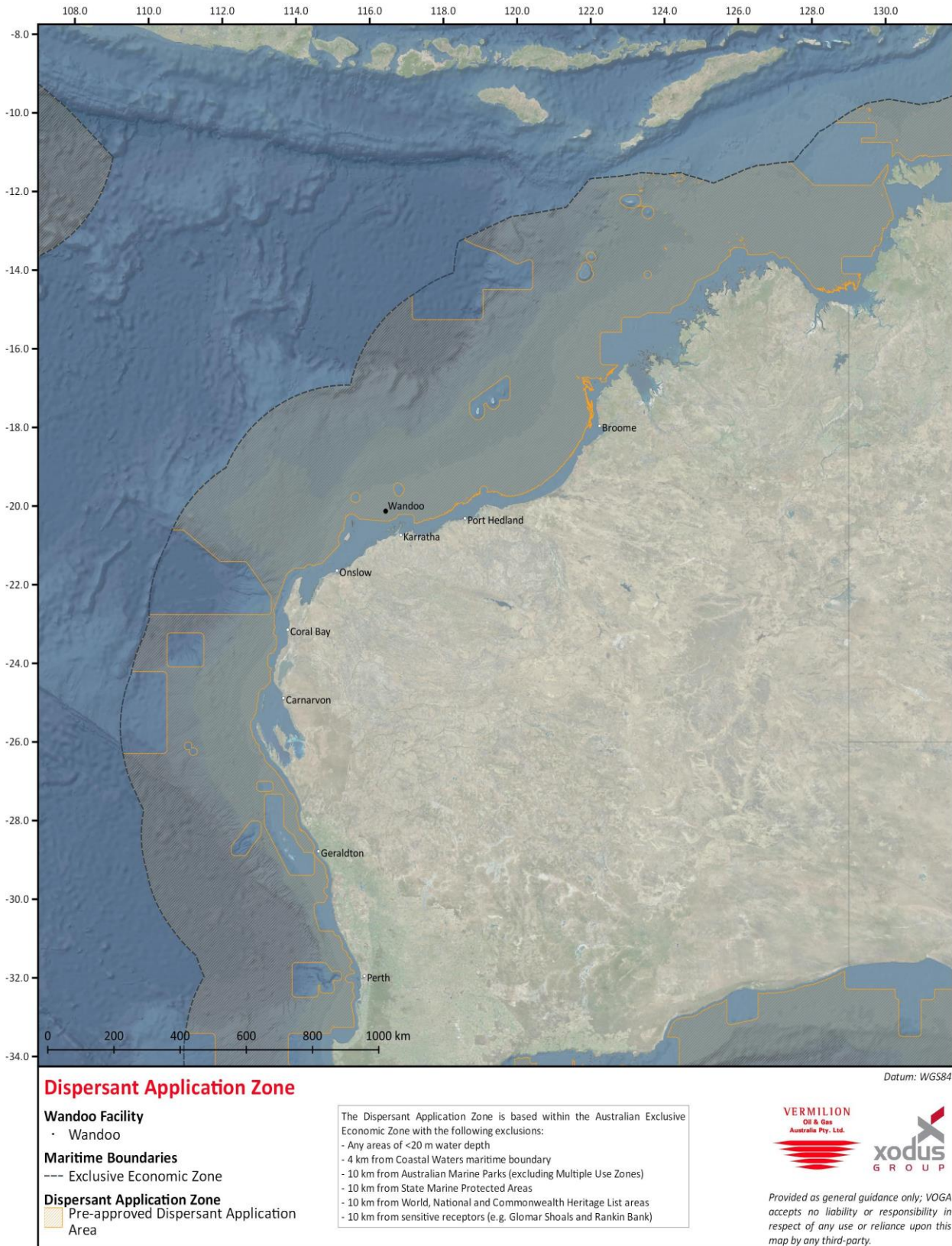

Figure 6-6: Chemical dispersant application zone

Table 6-31: Potential impacts of the application of dispersant on ecological sensitivities

Ecological sensitivity	Key features	Impact of dispersant	Impact of oil dispersed in the water column	Impact of oil	Actions/status/response
Marine mammals	<p>Marine mammals which are listed as Threatened or Migratory under the EPBC Act, including cetaceans, one dugong and one pinniped, may potentially occur in the EMBA.</p> <p>Migrating humpback whales are present in the region from July to October. The recognised peak in the humpback whale northern migration is mid-late July to August and the southern migration peak is late August to September (Jenner et al., 2001). The migration BIA for the humpback whale is located within the Hydrocarbon Area.</p> <p>Pygmy blue whale feeding area in the Perth Canyon, whales feed between January and April, with evidence suggesting that feeding likely occurs along the shelf in water depths from 500 to 1,000m (Jenner and Jenner, 2008; McCauley et al., 2004). A Distribution BIA for the pygmy blue whale is located within the Hydrocarbon Area.</p> <p>Dugongs are often found in shallow waters where seagrass beds flourish. Dugongs are migratory and are known to occur around the islands of the NWS, Shark Bay, Exmouth Gulf and the Dampier Archipelago and Ashmore Reef where seagrass beds occur (Gales et al., 2004).</p> <p>Several areas within the EMBA have been recognised as critical habitats for marine mammals. These include the humpback whale calving grounds in the southern Kimberley region (Camden Sound) (DEH, 2005a), the humpback whale resting areas in Shark Bay and Exmouth Gulf, the dugong feeding grounds in Shark Bay, Exmouth Gulf and coastal waters near Broome, the Australian snubfin dolphin and Indo-Pacific humpback dolphin foraging and calving area in Roebuck Bay and the Australian sea lion breeding and foraging area in the Houtman Abrolhos Islands and Jurien Bay</p>	<p>The impacts of the dispersants themselves can be considered less than that of entrained oil, given the toxicity values for the dispersant, and Wandoo Crude</p> <p>An additional potential impact of dispersants is the removal of natural water repellent oils from marine mammal fur (sea lion), making them less buoyant and susceptible to hypothermia (Kucklick et al., 1997). However, this is unlikely to occur given that dispersant application is not proposed in known sea lion habitat, and concentrations of dispersant will reduce outside of the application area.</p>	<p>Generally, the use of dispersant will increase the amount of oil that physically mixes into the water column thus reducing the potential for a surface slick to come into contact with marine mammals that surface to breathe.</p> <p>Spill modelling results for the loss of well control scenario predicts that the use of dispersant will reduce the proportion of oil on the sea surface during all seasons.</p> <p>Spill modelling results predict that the use of dispersants will increase the potential zones of low and moderate concentration of entrained hydrocarbons.</p> <p>Dispersed oil is unlikely to affect marine mammals due to the low toxicity of dispersed oils, low period of exposure that could occur and the low dosage of oil that may be received.</p>	<p>The impact assessments for the well loss of control and CGS spill scenarios (Sections 6.2.3 and 6.4.3) predict that major impacts to marine mammals are likely without the use of dispersants.</p>	<p>The application of dispersant reduces the oil level on the surface in most cases thus reducing the level of exposure to the oil of surface dwelling organisms such as marine mammals.</p> <p>Dispersant should be applied in open water where surface of trajectory modelling indicates high priority protection areas are at risk from oiling.</p> <p>During a spill response, real-time data is required to confirm whether dispersant will have a net benefit based on the conditions, spill location and application area.</p>

Ecological sensitivity	Key features	Impact of dispersant	Impact of oil dispersed in the water column	Impact of oil	Actions/status/response
Marine reptiles	<p>Turtles</p> <p>Several species of turtle listed under the EPBC Act may occur in the EMBA.</p> <p>The green turtle nesting area nearest to the Operational Area is located on the west coast of Barrow Island (approximately 100km from the Operational Area). Critical nesting habitat is also located at Ashmore Reef and the Coco Islands (>1,000km from the Operational area).</p> <p>The major hawksbill rookeries are the Dampier Archipelago (40km from the Operational Area), Montebello Islands (approximately 90km from the Operational Area) and Lowendal Islands (approximately 80km from Operational Area).</p> <p>Flatback turtles have major nesting sites at Barrow Island (approximately 100km from Operational Area), Mundabullangana Station (approximately 160km from Operational Area), Eighty Mile Beach (approximately 300km from Operational Area), Roebuck Bay (approximately 600km from the Operational Area) the Lacepede Islands (approximately 690km from the Operational Area), Dampier Archipelago (approximately 40km from Operational Area), the Montebello Islands (approximately 90km from the Operational Area), Port Hedland (approximately 220km from the Operational Area), and the Lowendal Islands (approximately 80km from Operational Area).</p> <p>Shallow water habitats are key inter-nesting sites in the Dampier Archipelago, Ningaloo Reef and offshore islands, e.g. Barrow Island, Montebello Islands. Critical nesting periods between November and March.</p> <p>Snakes</p> <p>Species of sea snake listed under the EPBC Act may occur in the EMBA.</p> <p>The short-nosed sea snake prefers the reef flats or shallow waters along outer reef edges in water depths to 10m and generally stay within 50m of the reef.</p> <p>The leaf-scaled sea snake is found only on the reefs of the Sahul Shelf in Western Australia, especially on Ashmore and Hibernia Reefs in the North-west Bioregion.</p> <p>Crocodile</p> <p>The saltwater crocodile listed as migratory under the EPBC Act may occur in the EMBA</p>	<p>Sea turtles may be exposed to dispersants either internally (eating or swallowing oil, or inhaling of volatile oil related compounds) or externally (swimming in oil or dispersants, or oil or dispersants on skin and body) (NOAA, 2012).</p> <p>Direct contact of skin with petroleum compounds or dispersants may cause skin irritation, chemical burns, and infections.</p> <p>Inhalation of dispersants may irritate or injure the respiratory tract which may lead to inflammation or pneumonia.</p> <p>Ingestion of petroleum compounds or dispersants may cause injury to the gastrointestinal tract, which may affect the animals' ability to absorb or digest foods.</p> <p>Absorption of petroleum compounds or dispersants may damage liver, kidney, and brain function as well as causing anaemia and immune suppression.</p> <p>As chemically dispersed oil moves away from the spray zone, the dissolution of dispersant results in lower potential toxicity to species exposed to the dispersed oil.</p> <p>There are no specific studies on sea snakes reported in the scientific literature, but impacts are likely to be similar to those described for turtles as they are often seen at the sea surface.</p>	<p>The use of dispersants increases the amount of oil that physically mixes into the water column thus reducing the potential for a surface slick to come into contact with marine reptiles such as turtles that surface to breathe.</p> <p>The use of dispersants may also reduce the volume of oil that ends up on shorelines and the probability of oil reaching shorelines, thus reducing the impact to hatchling and turtles using nesting beaches.</p> <p>Spill modelling results predict that the use of dispersant will reduce the proportion of oil on the sea surface during all seasons and reduce the average volume of oil to shorelines in the majority of cases Spill modelling results also predict that the use of dispersants will increase the potential zones of low and moderate concentration of entrained hydrocarbons</p> <p>Dispersed oil is unlikely to affect marine reptiles due to its low toxicity, the low periods of exposure that could occur and the low dosage of oil that may be received.</p>	<p>The impact assessments for the well loss of control and CGS spill scenarios predict that major impacts to marine reptiles are likely without the use of dispersants.</p>	<p>The application of dispersant reduces the oil level on the surface thus reducing the level of exposure to the oil of marine reptiles that return to the sea surface to breathe.</p> <p>The greatest impacts are posed to shoreline nesting sites. The application of dispersant will also reduce the volume and likelihood of oil reaching key habitat locations, reducing potential exposure to nesting turtles.</p> <p>Chemical dispersants should only be applied in open water where surface oil trajectory modelling indicates high priority protection areas are at risk from oiling if the spilt oil remains on the water surface.</p>

Ecological sensitivity	Key features	Impact of dispersant	Impact of oil dispersed in the water column	Impact of oil	Actions/status/response
Fish, sharks and rays	<p>Species of shark, sawfish, and rays listed as Threatened and/or Migratory under the EPBC Act may potentially occur in the EMBA</p> <p>Mako sharks have a widespread distribution and are unlikely to occur in large numbers.</p> <p>Eighty Mile Beach, Roebuck Bay and Camden Sound are important areas for sawfish species and the northern river shark</p> <p>Fish are present in the EMBA.</p>	<p>No specific studies reported in the scientific literature, but impacts are likely to be similar to those described for fish as they are predominantly pelagic species.</p> <p>As chemically dispersed oil moves away from the spray zone, the dissolution of dispersant results in lower potential toxicity to species exposed to the dispersed oil.</p>	<p>Dispersant application results in an increase in oil becoming entrained in the water column this significantly increased the potential for exposure of sharks throughout the water column (Gulf Coast Research Laboratory, 2013).</p> <p>A study conducted by Fuller et al. (2004) using two fish species, <i>Cyprinodon variegatus</i> and <i>Menidia beryllina</i>, one shrimp species, <i>Americamysis bahia</i> (formerly <i>Mysidopsis bahia</i>), and the luminescent bacteria <i>Vibrio fischeri</i> these, indicated that the toxicity of chemically dispersed oil preparations was equal or less toxic than that of the oil alone.</p> <p>The potential for impact is highest at the point of application, where the concentration of dissolved hydrocarbons and/or dispersant chemicals is greatest.</p> <p>Exposure to dispersed oil is concentrated in the top portion of the water column and decreases fairly rapidly over time in areas with depths over 9m and good circulation (NRC, 1989; SEA, 1995).</p> <p>Spill modelling results predict that the use of dispersants will increase the potential zones of low and moderate concentration of entrained hydrocarbons.</p> <p>Entrained oil is unlikely to affect species that exist in the water column due to its low toxicity, the low periods of exposure that could occur and the low dosage of oil that may be received.</p>	<p>The impact assessments for the well loss of control and CGS spill scenarios predict that minor impacts to fish and sharks are likely without the use of dispersants.</p>	<p>Chemical dispersants should only be applied in open water where surface oil trajectory modelling indicates high priority protection areas are at risk from oiling if the spilt oil remains on the water surface.</p> <p>The whale shark aggregation period from March to June will be considered in the SIMA.</p>
Seabirds	<p>Threatened Migratory species of birds may potentially occur within the EMBA.</p> <p>Migratory species occur at the Ramsar sites at Eighty Mile Beach and Roebuck Bay, but also at the Rowley Shoals and other undisturbed offshore islands. The timing of migration varies between species; however, birds typically begin to arrive in August to September and depart around March to April (Rogers et al., 2011).</p> <p>Important seabird breeding sites within the region include the Montebello/Barrow islands group, Rowley Shoals, Eighty Mile Beach and Roebuck Bay.</p>	<p>Dispersants may remove the natural water repellent oils from bird feathers (Boyd et al., 2001) making them less buoyant and more vulnerable to hypothermia.</p> <p>Higher metabolic rates were also found in birds exposed to dispersant, presumably due to the increased energy suspended to maintain a normal body temperature (Lambert et al., 1982).</p>	<p>The use of dispersants increases the amount of oil that physically mixes into the water column, thus reducing the potential for a surface slick to come into contact with seabirds that frequent the air water interface.</p> <p>Peakall et al. (1987) concluded that, from the toxicological perspective, the effects of oil and chemically dispersed oil on seabirds were similar, based on sub-lethal responses at the biochemical and physiological level.</p> <p>Similarly, studies on the effects of oil on the hatching success of bird eggs (summarised in NRC, 1989) also indicated that toxicities of oil and dispersed oil were similar.</p> <p>Spill modelling results for the loss of well control scenario indicates that the use of dispersants will reduce the proportion of oil on the sea surface during all seasons.</p>	<p>The impact assessments for the well loss of control and CGS spill scenarios predict that major impacts to seabirds likely without the use of dispersants.</p>	<p>Application of dispersant or dispersed oil in the water column presents much lesser risk to seabirds and waders than leaving an oil spill untreated, as it reduces their exposure to hydrocarbons (French-McCay, 2004).</p> <p>Dispersant should be applied in open water where trajectory modelling indicates high priority protection areas are at risk from oiling.</p>

Table 6-32: Potential impacts of the application of dispersant on ecological sensitivities

Habitat sensitivity	Key habitat types	Impact of dispersant	Impact of oil dispersed in the water column	Impact of oil	Actions/status/response
Hard corals	Present in EMBA. The closest significant coral reefs to the Operational Area are those fringing the Dampier Archipelago and Montebello Island groups, 40 and 90km from the Operational Area, respectively	Recent studies of coral larvae clearly demonstrate impacts of dispersants and dispersed oil on corals and, because of their life history and habitat characteristics, these species may be especially susceptible (NAP, 2005). Settlement of <i>P.astreoides</i> larvae, in particular, significantly decreases after exposure to all concentrations of dispersant [25ppm, 50ppm, 100ppm], with no settlement occurring at the highest concentrations. Constant exposure to Corexit® 9500 also caused dramatic declines in larval survivorship, resulting in complete larval mortality (100%) after exposure to both medium and high concentrations [50ppm, 100ppm] (Goodbody Grinley et al., 2013). It is unlikely that corals will be impacted by chemical dispersant as the concentration of dispersant reduces rapidly outside the application zone.	The application of dispersant will, typically, increase oil exposure for water column and bottom dwelling organisms such as hard coral (Boyd, et al., 2001). Spill modelling results indicate that the use of dispersant increases the extent of entrained hydrocarbons in the water column. However, coral sensitivity to dispersed oil depends on the concentration and the length of exposure. Very high dispersed oil concentrations and long exposures can kill coral, whereas lower doses and short-term exposure show few, if any, impacts, many of which are reversible (Shingenaka et al., 2010).	The impact assessments for the well loss of control and CGS spill scenarios predict that major impacts to hard corals are likely without the use of dispersants.	Dispersant-use decisions to treat oil already over a reef should consider the type of oil and location of the reef. No dispersant will be sprayed in areas with water depth of less than 20m depth. Dispersant use should be considered to treat oil over reefs in water depths greater than 20m if the alternative is to allow the oil to impact other sensitive habitats on shore. Dispersion is not recommended to treat oil already in reef habitats having low-water exchange rates (e.g. lagoons and atolls) if mechanical clean-up methods are possible.
Coral spawning	Spawning events have been observed throughout the Dampier Archipelago in March and April (Stoddart and Gilmour, 2005) and along the Ningaloo Coast during March (Simpson, 1993).	Dispersants resulted in significant inhibition to <i>Acropora</i> sperm and eggs (Negri and Heyward, 2000).	Chemically dispersed oil exposures resulted in a dramatic increase in acute toxicity to both coral species larvae. In addition, the authors reported that dispersants and dispersed oil treatments caused larval morphological deformations, loss of normal swimming behaviour, and rapid tissue degeneration (Epstein et al., 2000).	Chronic oil pollution damages the reproductive system of scleractinian corals (Rinkevich and Loya, 1977). Gametes of most spawning species tend to rise to the surface just after spawning, where they are more likely to encounter oil and thus more likely to suffer damage (Harrison et al., 1984).	Major spawning events occur after full moons in March/April, minor spawning events occur after full moon in February and May. The coral spawning period will be considered in the SIMA.
Macroalgae	Macroalgal habitat is most likely associated with coastal reefs and other hard substrates. It is widespread throughout the EMBA and there are no specifically identified areas of significant environmental value	Virtually all macroalgae, in particular rhodophyte species are more susceptible to dispersants than to oil (Edgar & Barrett, 1995).	Complete or partial mortality of kelps is possible at exposure concentrations (>10ppm) of TPH as chemically dispersed oil (Ross, 2002). Spill modelling results indicate that the use of dispersants will increase the extent of entrained hydrocarbons. Entrained oil at these thresholds is unlikely to cause mortality to sea kelp.	The impact assessments for the well loss of control and CGS spill scenarios predict that serious impacts to macroalgae are likely without the use of dispersants.	When the addition of a chemical dispersant is deemed necessary to protect other resources in the area, the macroalgae may still recover depending on the dispersant used.
Seagrass	Present in EMBA. Extensive seagrass meadows are known to occur at Shark Bay, Exmouth Gulf and Roebuck Bay and are reported to provide important feeding habitat for dugongs and green turtles (Sheppard et al., 2010; Bjorndal, 1985)	Most dispersant alone treatments caused photosynthetic stress to the seagrass, and in some cases, this was greater than the dispersed oil and the oil alone treatments (Wilson and Ralph, 2008). Ralph and Burchett (1998) found that laboratory-cultured <i>Halophila ovalis</i> was reasonably tolerant of petrochemical exposure and there was little difference between exposure to oil, oil + dispersant and dispersant alone.	Seagrasses have been shown to absorb more aliphatic and aromatic oil fractions when the oil is dispersed, therefore increasing the toxicity (den Hartog, 1984). Non-dispersed oil, in general, leads to less photosynthetic stress to <i>Zostera capricorni</i> and <i>Halophila ovalis</i> compared with the addition of a chemical dispersant (Wilson and Ralph, 2008).	The impact assessments for the well loss of control and CGS spill scenarios predict that major impacts to seagrass are likely without the use of dispersants.	When the addition of a chemical dispersant is deemed necessary to protect other resources in the area, the seagrass may still recover depending on the dispersant used.

Habitat sensitivity	Key habitat types	Impact of dispersant	Impact of oil dispersed in the water column	Impact of oil	Actions/status/response
Mangroves	<p>Mangroves are present in EMBA but not present within the Operational Area. The nearest areas of mangrove habitat occur at the Dampier Archipelago</p> <p>Other significant areas of mangrove habitat occurring within the EMBA include the Montebello Islands, Ningaloo Coastline, scattered areas along the coast between Onslow and just north of Port Hedland and Hosnies Springs, Christmas Island</p>	<p>Dispersant causes significant and short term leaf damage to treated Avicennia when sprayed on leaves and pneumatophores (Wardrup, 1987).</p>	<p>Dispersed oil is readily flushed by tidal movement and the resident time of oil and consequent exposure time of flora and fauna is much shorter compared to oil with no dispersant (Schuler and Bacer, 2006). Laboratory and field studies have shown that the use of dispersant significantly reduces the death of mangrove trees (Duke et al., 1998 a, b; Duke and Burns, 1999).</p> <p>Spill modelling results predict that the use of dispersant will reduce the proportion of oil on the sea surface during all seasons and reduce the average volume of oil to shorelines in the majority of cases. Spill modelling results also predict that the use of dispersants will increase the potential zones of low and moderate concentration of entrained hydrocarbons</p> <p>Dispersed oil was significantly less toxic to mangrove trees than oil only treatments (Burns et al., 1999).</p>	<p>The impact assessments for the well loss of control and CGS spill scenarios predict that major impacts to mangroves are likely without the use of dispersants.</p>	<p>Any action taken to prevent or reduce stranding of oil in mangrove forests is likely to have a positive effect in reducing damages to mangroves. Chemical dispersion of oil in deep water, away from near-shore environments, is likely to allow dilution of dispersed oil such that exposure of sensitive subtidal environments to toxic concentrations is not likely to occur.</p>
Intertidal beaches/mudflats/rocky shorelines/intertidal reef platforms	<p>No intertidal reefs, beaches/mudflats occur within the Operational Area, which is approximately 40km from the nearest landfall. They are present within the EMBA. Three intertidal beach/mudflat areas of international conservation significance occur within the region (Bandicoot Bay, Eighty Mile Beach and Roebuck Bay). Bandicoot Bay is a Conservation Reserve within the Montebello/Barrow Islands Marine Management Area and Eighty Mile Beach and Roebuck Bay are listed under the Ramsar Convention and are afforded specific protection under the EBPC Act</p>	<p>Lethal and sub-lethal effects of most dispersants occur at 0.1 to 100ppm for marine invertebrates including those that inhabit intertidal reefs, beaches and mudflats (Volkman et al., 1994).</p>	<p>Potential impacts on invertebrates and macroalgal species associated with reef are possible from exposure to entrained hydrocarbons. However, these impacts are considered less significant when compared to the resultant effects from direct exposure to oil.</p> <p>Spill modelling results show that the use of dispersant reduces the volume of oil to shorelines.</p>	<p>The impact assessments for the well loss of control and CGS spill scenarios predict that minor impacts to intertidal beaches/mudflats/rocky shorelines/intertidal reef platforms are likely without the use of dispersants.</p>	<p>Dispersing oil before it impacts intertidal habitats is the preferred strategy in most cases. In cases where the oil was dispersed prior to contacting these habitats, the net ecological effect was much less severe compared to when oil was allowed ashore (NRC, 1989).</p> <p>Where the intertidal environment is highly sensitive to oil pollution, the no-action response option has a relatively high probability of resulting in significant adverse environmental impacts, and therefore, the no-action option is not recommended (Ballou et al., 1987).</p>

Table 6-33: Potential impacts of the application of dispersant on Socioeconomic Sensitivities, KEFs and Protected Areas

Sensitivity/feature or area	Key features	Impact of dispersant	Impact of chemically dispersed oil	Impact without use of dispersant	Actions/status/response
Socio-economic sensitivity					
Fisheries (and aquaculture)	Several offshore and coastal fisheries occur within the EMBA both in shallow water (<20m depth) and much deeper offshore waters. It is unlikely that fishing activity will occur in the Operational Area due to the restricted zone. No aquaculture activities take place within the Operational Area. There are aquaculture facilities located in near-shore waters of the EMBA, with the closest known facilities to the Operational Area being at the Dampier Archipelago	Dispersants must be used with care so as not to cause tainting of shellfish and captured or cultivated stock. As a general guide, it is not prudent to use dispersant in shallow waters where fishing or aquaculture is important. Application of dispersant will have less effect on demersal and deep-water trawl fisheries as compared to the shallow water coastal fishery.	Closure of a fishery for reasons of contamination or tainting of the exploitable life stages – where oil concentrations are >1ppm is assumed to cause tainting – will result in closure of fishing zone for one month (Ross, 2002). Dispersant application results in a high percentage of hydrocarbons becoming entrained in the top 10m of the water column which increases the potential to direct exposure to hydrocarbons to pelagic species, sessile aquaculture species and also to planktonic life stages of other fish species. Dispersant increases the volume of entrained hydrocarbon also increasing the potential for tainting.	The impact assessments for the well loss of control and CGS spill scenarios predict that serious impacts to fisheries are likely without the use of dispersants.	Dispersant can be applied in open water where trajectory modelling indicates that oil is heading offshore away from coastal areas. The use of dispersants over important fishing grounds or aquaculture areas, except where ecologically important nursery habitats are threatened (mangroves, seagrasses and coral reefs), is not recommended. Dispersant use in areas where eggs and larvae of important commercial species are present is not recommended, except where important nursery habitats are threatened (mangroves, seagrasses and coral reefs).
Shipping	The Dampier shipping fairway lies within 1.2km of the Operational Area. There are significant commercial shipping activities within the EMBA	Negligible.	Negligible.	The impact assessments for the well loss of control and CGS spill scenarios predict that minor impacts to shipping are likely without the use of dispersants.	Dispersant can be applied in the vicinity of the shipping fairways.
Other users	A number of tourist destinations occur within the EMBA. The Operational Area is surrounded by a number of other leaseholders that operate petroleum related activities.	The dispersant application zone may impact on operations and people.	The impacts of dispersed oil on tourism and petroleum related activities are likely to be similar to the impacts of the oil spill. Tourism numbers to the area are likely to reduce during dispersant application. Recreational activities are likely to close temporarily due to risks to human health. Dispersant application has the potential to disrupt petroleum related activities, potentially halting production or exploration with associated economic impact.	The impact assessments for the well loss of control and CGS spill scenarios predict that serious impacts to other users are likely without the use of dispersants.	Dispersant will be applied in open water within the WA-14L Operational area and within a nominal 20km radius of the spill location. Application of dispersant in areas outside the designated application area or the SIMA zone will only be done in accordance with the oil spill response plan.
Protected areas					
World Heritage Areas	WHA occur within the EMBA and may be impacted in the event of an instantaneous CGS spill.	The impact of dispersant on the values associated with WHAs has been assessed in terms of key ecological and socio-economic sensitivities in the sections above	The impact of dispersed oil on the values associated with WHAs has been assessed in terms of key ecological and socioeconomic sensitivities in the sections above.	The impact of not using dispersant on values associated with WHAs has been discussed in impact assessments for the well loss of control and CGS spill scenarios.	Dispersant will be sprayed in accordance with the dispersant application zones outlined above.
Commonwealth Marine Protected Areas	There are no Commonwealth Marine protected areas within the Operational Area; however they do occur within the EMBA	The impact of dispersant on the values associated with Commonwealth Marine Protected Areas has been assessed in terms of key ecological and socio-economic sensitivities in the sections above.	The impact of dispersed oil on the values associated with Commonwealth Marine Protected Areas has been assessed in terms of key ecological and socioeconomic sensitivities in the sections above.	The impact of not using dispersant on values associated with Commonwealth Marine Protected Areas has been discussed in impact assessments for the well loss of control and CGS spill scenarios.	Dispersant will be sprayed in accordance with the dispersant application zones outlined above. Dispersant will not be used in Commonwealth Marine Protected Areas.

Sensitivity/feature or area	Key features	Impact of dispersant	Impact of chemically dispersed oil	Impact without use of dispersant	Actions/status/response
State Marine Protected Areas	State Marine Reserves do not occur within the Operational Area however they do occur within the EMBA	The impact of dispersant on the values associated with State Marine Protected Areas has been assessed in terms of key ecological and socio-economic sensitivities in the sections above.	The impact of dispersed oil on the values associated with State Marine Protected Areas has been assessed in terms of key ecological and socioeconomic sensitivities in the sections above.	The impact of not using dispersant on values associated with WHAs has been discussed in impact assessments for the well loss of control and CGS spill scenarios.	Dispersant will be sprayed in accordance with the dispersant application zones outlined above. Dispersant will not be used in State Marine Protected Areas.
KEFs					
Ancient coastline at 125m depth contour	Outlined in Section 4.7.8	The impact of dispersant on the values associated KEFs have been assessed in terms of key ecological and socio-economic sensitivities in the sections above.	The impact of dispersed oil on the values associated with KEFs have been assessed in terms of key ecological and socio-economic sensitivities in the sections above.	The impact of not using dispersant on values associated with KEFs have been discussed in impact assessments for the well loss of control and CGS spill scenarios. Impacts ranging from minor to catastrophic are predicted.	Dispersant will be sprayed in accordance with the dispersant application zones outlined above.
Canyons linking the Cuvier Abyssal Plain and the Cape Range Peninsula					
Commonwealth Waters adjacent to Ningaloo Reef					
Continental slope demersal fish communities					
Western demersal slope					
Exmouth Plateau					
Glomar Shoals					
Mermaid Reef and Commonwealth waters surrounding Rowley Shoals					
Wallaby Saddle					
Ancient coastline at 90m to 120m depth					
Commonwealth marine environment surrounding Houtman Abrolhos Islands					
Perth Canyon and adjacent shelf break and other west coast canyons					
Western rock lobster					
Commonwealth marine environment within and adjacent to the west coast in-shore lagoons					
Ashmore Reef and Cartier Island surrounding Commonwealth waters					
Canyons linking the Argo Abyssal Plain and the Scott Plateau					
Carbonate bank and terrace system of Sahul Shelf					
Seringapatam Reef and Commonwealth waters in the Scott Reef Complex					
Pinnacles of Bonaparte Basin					

6.5.3.4 Mechanical dispersion

Hazard description

Activities associated with mechanical dispersion include regular vessel operations and use of vessels for propeller washing.

Impact assessment

In addition to the generic vessel impacts listed in Section 6.5.3.2, the potential use of vessels for propeller-washing to mechanically disperse spilt oil in shallow coastal waters introduces the potential for damage to sensitive seabed habitats such as coral reefs, macro-algae beds and seagrasses. Potential damage could occur from accidental vessel grounding or propeller-wash (turbulence) in shallow water. These impacts could include scouring of sediments and physically damaging/removing subtidal habitat, together with any supported invertebrate communities. Mechanical dispersion will only be carried out in waters deeper than 20m; hence impacts to sediments and subtidal habitats are unlikely.

6.5.3.5 Containment and recovery

Hazard description

Activities associated with containment and recovery includes:

- Vessel and aircraft operations;
- Transport and disposal of waste; and
- Vessel boom anchoring, retrieval or sorbents.

Impact assessment

The impacts associated with vessel and aircraft operations are outlined in Section 6.5.3.2.

A containment and recovery spill response should generally have an increase in net environmental benefit for most species and habitats. However, during a shallow-water response, there is the potential that disturbance to benthic communities could occur due to vessel activities and/or boom anchoring. Potential impacts to marine habitats associated with anchoring are discussed in Section 6.22. Vessel size and/or draft will limit speed, manoeuvrability and access to operate.

Physical disturbance of habitat during deployment and retrieval of sorbents could occur. Poorly deployed or tended sorbent material could also crush or smother sensitive organisms. If sorbents are left in place for too long, there is a risk that the sorbents can break apart and become an ingestion hazard to wildlife.

Waste generated from the containment and recovery process includes oily sorbents. The collection of oil and the transport of oil and oiled equipment to either an offshore processing or an onshore disposal/wash-down site will create the potential for an accidental release of hazardous wastes as described in non-hazardous and hazardous waste (Section 6.9). Free-floating oil removed during skimming operations can be recycled. Emulsions formed during the process must be treated (broken) before recycling. Oil-contaminated waste from the treatment phase will be treated as waste water.

6.5.3.6 Protection and deflection

Description of hazard

Activities associated with protection and deflection, include:

- Vessel and aircraft operations;
- Transport and disposal of waste;
- Shallow water operation-vessel boom anchoring, retrieval or sorbents; and
- Use of barriers/berms.

Impact assessment

Protection and deflection will involve the use of vessels near shallow coastal areas where sensitive habitats and aggregations of wildlife may be present. In addition to generic vessel impacts described in Section 2.8.14.2, the operation of vessels near shallow waters increases the risk of damage to sensitive habitats (hard corals, macro-algae, and seagrasses) from vessel grounding, manoeuvring and anchoring. Potential impacts to marine habitats associated with anchoring are discussed in Section 6.22. Sensitive habitat areas will be avoided during vessel grounding and anchoring.

Poorly placed deflection booms could potentially direct floating oil to shoreline areas where impacts could be more severe (e.g. mangrove areas) and, also, exacerbate the level of impact and recovery time for the ecosystem. Sensitive receptors identified in this EP will be avoided when placing protection and deflection booms.

Sediment barriers used for protection and deflection may become contaminated on the oil side and filter fence materials will have to be disposed of as oily wastes.

6.5.3.7 Shoreline clean-up

Description of hazard

Activities associated with shoreline clean-up include:

- Vessel and aircraft operations;
- Transport and disposal of waste; and
- Shallow water and shoreline operations.

Impact assessment

OSTM indicates that there is a high probability of shoreline contact under a range of scenarios, with locations most likely to be impacted being the Montebello Islands, the Rowley Shoals and the coastline between Port Hedland and Broome.

Accessing shorelines for clean-up will have associated ecological constraints, especially if accessing uninhabited, sensitive coastal areas. Environmentally intrusive or potentially damaging activities should only be considered if there is a positive net environmental benefit. If significant shoreline oiling occurs, removal of vegetation may be required. Habitat removal will have significant impacts on the function of coastal ecosystems.

Physical clean-up methods can alter the elevation or profile of beaches, which may lead to erosion of beaches following the clean-up process, particularly if heavy machinery is used. Shoreline clean-up techniques are outlined in Section 2.8.14.7. The impact of shoreline clean-up techniques on various habitat types is outlined in Table 6-34.

The use of vessels to transport personnel to shoreline areas also increases the level of generic vessel impacts, as described in Section 2.8.14.2.

6.5.3.8 Oiled wildlife response

Description of hazard

Oiled wildlife response has the potential to cause impacts to marine fauna. Activities associated with oiled wildlife response that can cause impacts to marine fauna include:

- Hazing;
- Pre-emptive capture;
- Search and capture; and
- Field stabilisation.

Impact assessment

Hazing involves the use of visual, auditory or sensory deterrents to keep healthy marine fauna away from the oil. This can lead to the separation of groups or adults/juveniles, collisions with marine fauna, inadvertent movement of animals into the oiled area, or scattering of oiled animals.

Pre-emptive capture involves the capture and relocation of marine fauna before they become oiled. Potential impacts include relocation to inappropriate areas that will not support the animal's requirements (e.g. habitat, food sources).

The goal of search and capture is to collect as many live oiled animals as quickly as possible and in the best possible condition to maximise survival. Marine fauna may be injured during collection and, if their condition is already poor due to oil contact, inexperienced handling can rapidly exacerbate their condition.

Field stabilisation is required prior to further treatment of oiled animals, to ensure they can cope with the cleaning and rehabilitation process that will follow. Effective field stabilisation requires deployment of adequate handlers to appropriate locations in a timely manner.

Although there are potential impacts to marine fauna from oiled wildlife response, these impacts are likely to be less than the potential impacts to marine fauna from oil, as outlined in Section 6.2.3. Following a spill, some slightly oiled fauna may survive, but those that are very heavily oiled will probably die. Prompt initialisation of an oiled wildlife response that quickly and effectively collects wildlife and provides a means for humane euthanasia, or rehabilitation and release, will minimise suffering.



Table 6-34: Potential impacts of shoreline clean-up activities on various habitat types

Habitat type	Key features	Undertaking shoreline clean-up	Not undertaking shoreline clean-up	Priority/action
Mangroves	<p>Mangroves are productive coastal forest systems, providing habitat and shelter for infauna, epifauna, gastropods, crustaceans, fish and other marine species. They occur in relatively flat areas with soft sediment.</p> <p>Mangroves are not present within the Operational Area. The nearest areas of mangrove habitat occur at the Dampier Archipelago</p>	<p>Natural recovery is the preferred clean-up method as mangroves have been shown to be more easily damaged by physical disturbance caused by clean-up than the oil itself.</p> <p>Mechanical removal and high-pressure flushing has the potential to cause damage to mangroves and should not be attempted.</p> <p>Trampling associated with manual clean-up also has the potential to cause damage to mangroves.</p> <p>Sorbents may be used, as they eliminate the requirement for foot traffic and mechanical equipment. However, this technique is not recommended for high energy shorelines, as sorbents may be lost during periods of high wave action or tidal movement. It may also generate large volumes of waste.</p> <p>LP flushing with seawater may be used for thick films only. It has the potential to cause removal or mortality of surface organisms and surface and near surface habitat disturbance.</p>	<p>Mangroves are very sensitive to hydrocarbons; even light oiling can result in defoliation and mortality.</p> <p>The recovery rate of mangrove areas depends on the dominant species involved. It is generally estimated that 25 to 40 years may be required for a mangrove community to re-establish itself (O’Sullivan et al., 2001).</p>	<p>High</p> <p>As certain methods of shoreline clean-up have the potential to cause damage to mangrove habitats, focus should be on prevention of further hydrocarbon entry by using protection and deflection.</p> <p>If oil ends up in mangrove habitats, leaving residual oil to weather and degrade naturally is usually recommended, as mangroves have been shown to be more easily damaged by the physical disturbance caused by clean-up teams and vehicles, than by the oil itself.</p>



Habitat type	Key features	Undertaking shoreline clean-up	Not undertaking shoreline clean-up	Priority/action
Rocky shorelines/intertidal reef platforms				
Cliffs	Vertical or sloped escarpments which restrict access to the underlying shores.	<p>Manual clean-up of cliffs may be difficult due to:</p> <ul style="list-style-type: none"> Absence of access; High sea states; or Dangerous working conditions. Sheltered cliffs associated with platforms may need cleaning. <p>In these cases, the following methods may be used:</p> <ul style="list-style-type: none"> LP washing with seawater (thick films only); and Manual removal. 	Oil may cause some damage to key species individuals. However, the spill will not cause significant habitat damage.	<p>Low</p> <p>Often cliffs do not require cleaning because:</p> <ul style="list-style-type: none"> Oil has been held off the coast by wave reflection; Self-cleaning is rapid due to exposure to high wave energies.
Intertidal platforms	<p>Intertidal reef platforms are located in the intertidal zone and consist of flat or gently sloping rock surfaces that provide habitat for many species such as molluscs (snails, oysters, chitons and gastropods).</p> <p>Platforms may be 'broken' with associated crevices, rock pools or boulders or 'unbroken' smooth surfaces with or without rock pools. Platforms may occur in association with other beach types.</p>	<p>Vacuum systems can be used to collect heavy (thick) or pooled deposits of oil where access is possible. Vacuum equipment also has the potential to cause damage to sensitive habitats and should not be used where foot traffic and equipment operation is restricted.</p> <p>Sorbents may be used as they eliminate the requirement for foot traffic and mechanical equipment. However, this technique is not recommended for high energy shorelines, as they may be lost during periods of high wave action. It may also generate large volumes of waste.</p> <p>LP washing with hot or cold seawater may be used, as this is effective to flush floating or loose oil out of tidal pools, depressions, crevices, etc. and remove oil from vegetation.</p> <p>Potential impacts of LP washing include removal or mortality of surface organisms and surface and near-surface habitat disruption. Oil can be transported to lower inter tidal or previously clean areas and subtidal</p>	Oil may cause some damage to key species individuals living in the rocks. However, the spill will not cause significant habitat damage.	<p>Low</p> <p>Platforms, which lie in the lower intertidal zone, are generally afforded a low priority, because oil tends not to adhere to the wet surfaces (i.e. wave exposed surface) and is rapidly removed.</p> <p>Platforms in the mid to upper intertidal zone are also generally self-cleaning and therefore oil does not persist.</p>



Habitat type	Key features	Undertaking shoreline clean-up	Not undertaking shoreline clean-up	Priority/action
		organisms may be buried by downslope sediment transport (Owens, 1998).		
Boulder beaches	Consist of large rocks (over 250mm in diameter).	<p>Manual removal may not be suitable as access to rocky shore is difficult and particular attention needs to be given to safety of workers on particular surfaces in addition to hazards of waves and tides (ITOPF, 2011).</p> <p>LP washing with hot or cold seawater may be used, as this is effective in flushing floating or loose oil out of tidal pools, depressions, crevices, etc. and in removing oil from vegetation.</p> <p>Potential impacts include removal or mortality of surface organisms and surface and near-surface habitat disruption. Oil can be transported to lower intertidal or previously clean areas, and subtidal organisms may be buried by downslope sediment transport (Owens, 1998).</p> <p>In areas of high concentrations of wildlife, where significant amounts of oil have stranded, loose sorbent material can be spread over oiled rocks to reduce contamination of fur or feathers (ITOPF, 2011). However, there is a potential that secondary contamination may result from drifting mats of the oil sorbent mixture.</p>	Oil may cause some damage to key species individuals living in the rocks. However, the spill will not cause significant habitat damage.	<p>Low</p> <p>Natural recovery is effective on weathered and heavy crude in most situations and causes the least environmental impact.</p>



Habitat type	Key features	Undertaking shoreline clean-up	Not undertaking shoreline clean-up	Priority/action
Cobble/pebble beaches	Consists of small areas of cobbles (diameter 6-25cm) and pebbles (diameter up to 6cm).	<p>Mechanical or manual clean-up techniques may not be suitable on this type of shoreline, as the movement of both vehicles and personnel have the potential to cause oil to penetrate into the spaces between stones and deep into the beach.</p> <p>LP washing with hot or cold seawater may be used, as this is effective in flushing floating or loose oil out of tide pools, depressions, crevices, etc. and removing oil from vegetation.</p> <p>Potential impacts include removal or mortality of surface organisms and surface and near-surface habitat disruption. Oil can be transported to lower inter tidal or previously clean areas, and subtidal organisms may be buried by downslope sediment transport (Owens, 1998).</p> <p>Surf washing may be suitable on moderate to high energy shorelines where moderately oiled sediments are located in the higher portions of the upper intertidal or supratidal zone.</p> <p>Potential impacts include:</p> <ul style="list-style-type: none"> Oil and/or sediments could damage healthy biological communities in the lower intertidal zone; Oil that is released is rarely fully contained and could impact adjacent areas; and Sediment loss resulting from alongshore suspension and movement of sediment in the water on fine-grained sediment beaches. 	<p>Vulnerable, especially to low viscosity or light oils which will rapidly penetrate the substrate and become buried. May persist for several years in areas of low or moderate energy.</p> <p>The sparse fauna levels that inhibit beaches are generally not sensitive to oil pollution (O'Sullivan et al., 2001).</p>	<p>Low</p> <p>Natural recovery is effective on weathered and heavy crude in most situations and causes the least environmental impact.</p>



Habitat type	Key features	Undertaking shoreline clean-up	Not undertaking shoreline clean-up	Priority/action
Beaches				
Intertidal sand and mudflats	<p>Intertidal flats are comprised of mud or sand, or a mixture of both. Sediments are often water saturated and may be very soft and, unconsolidated and, as such, cannot support vehicle or foot traffic.</p> <p>No intertidal reefs, beaches/mudflats occur within the Operational Area, which is approximately 40km from the nearest landfall. Three intertidal beach/mudflat areas of international conservation significance occur within the region (Bandicoot Bay, Eighty Mile Beach and Roebuck Bay). Bandicoot Bay is a Conservation Reserve within the Montebello/Barrow Islands Marine Management Area and Eighty Mile Beach and Roebuck Bay are listed under the Ramsar Convention and are afforded specific protection under the EBPC Act</p>	<p>Natural recovery is the preferable clean-up method for this type of shoreline, particularly where oil has been washed up on vegetation. On many occasions activities such as mechanical or manual clean-up have resulted in more damage than allowing natural recovery to take place due to trampling and substrate erosion.</p> <p>Where removal of oil is essential to prevent its remobilisation and spreading along the shoreline, LP flushing can be used. Potential impacts include removal or mortality of surface organisms and surface and near-surface habitat disruption. Oil can be transported to lower intertidal or previously clean areas, and subtidal organisms may be buried by downslope sediment transport (Owens, 1998).</p>	<p>Owing to their relative shelter and low wave energy, oil is likely to persist for long periods of time in sheltered muddy or sandy intertidal areas. In an eroding area oil is unlikely to accumulate, but in an area where accretion is taking place the oil may become buried under a layer of sediment.</p> <p>Most organisms living in these sediments are highly sensitive to the components of oil. Polychaete worms and other soft-bodied organisms are particularly susceptible to oil contamination.</p> <p>Recovery periods will be determined to a large extent by the degree of penetration and persistence of oil in the sediment. Experimental work has indicated two to four years for recovery (O’Sullivan et al., 2001).</p>	<p>High-medium</p> <p>Some mudflats also support diverse biological communities that are allocated a high priority for protection and cleaning.</p>



Habitat type	Key features	Undertaking shoreline clean-up	Not undertaking shoreline clean-up	Priority/action
Sandy beaches	<p>Sandy beaches are not present in the Operational Area. The nearest sandy beaches occur at the Dampier Archipelago (approximately 40km from the Operational Area) and the Montebello Islands (approximately 90km from the Operational Area).</p> <p>Shallow water habitats at offshore islands, such as the Dampier Archipelago, Barrow and Montebello Islands, provide key inter-nesting sites. Critical nesting periods occur between November and March.</p> <p>Sandy beaches are also considered a significant habitat for seabird nesting</p>	<p>Mechanical clean-up may be suitable for sandy beaches, provided the beach can support heavy machinery. This method can result in shoreline erosion if excessive material is removed without replacement. However, for most exposed beaches, the seasonal cycles of erosion and accretion are so large that the amount of material removed during clean-up operations is usually insignificant in comparison and will normally be replaced naturally.</p> <p>Manual clean-up may be used where access is restricted, if oiling is light, or if the beach cannot support heavy vehicles.</p> <p>Surf washing may be suitable on moderate to high energy shorelines where moderately oiled sediments are located in the higher portions of the upper intertidal or supratidal zone.</p> <p>Re-floated oil can be collected using booms and skimmers.</p> <p>Vacuum trucks or systems may be used on pooled oil, or where oil is very thick.</p>	<p>Oil can rapidly penetrate sandy beaches, particularly if the oil is mobile and the sand is dry. Under conditions of strong wave action and light oiling, any oil will be dispersed fairly rapidly. Heavier oils are liable to form an oil-water mixture that is heavier than water and may persist for long periods of time at or below the low water mark.</p> <p>Sand dwelling organisms have the ability to recover quickly, except during large scale pollution (O’Sullivan et al., 2001).</p>	<p>High</p> <p>Beaches used by nesting turtles and/or seabirds are given a high priority for protection and clean-up.</p> <p>A high protection priority will also be given to recreational beaches or those of high economic value.</p>

6.5.4 Control measures

All spill response strategies are subject to a SIMA which is described in the Wandoo Field OSCP [WAN-2000-RD-0001], and considers:

- Risk, impacts and benefits associated with each strategy and whether it is consistent with the EP;
- Environmental sensitivities and their priority (environmental significance, severity of impact and recovery time);
- Seasonal and migratory patterns; and
- State (WA) jurisdictional requirements and approvals.

The control measures applicable to each response strategy are outlined in the Wandoo Field OSCP [WAN-2000-RD-0001] and the Performance Standard: ELEMENT 8 – OIL SPILL RESPONSE (WAN-WNAB-CP-ER-02 and WAN-WNAB-CP-ER-03).

6.5.5 ALARP demonstration

6.5.5.1 Overview

VOGA's response strategies will allow responders to meet defined response objectives without causing more environmental damage than the oil spill itself. Once the initial response removes the bulk of the oil, additional mitigation measures focussed on removal of residual oil will be evaluated in terms of net environmental benefit.

In relation to a response for a spill of crude, the Incident Action Plan (IAP) within the Wandoo Field OSCP [WAN-2000-RD-0001] includes a SIMA process which is used to identify and prioritise key sensitivities vulnerable to a hydrocarbon impact. The incident action planning process considers the effectiveness of oil spill strategies and net environmental outcomes as part of the IAP decision-making process. The incident action planning process is outlined within the Wandoo Field OSCP [WAN-2000-RD-0001].

The SIMA processes and the SIMA matrix (refer to OSCP) prioritises VOGA's environmental sensitivities and assesses the individual net effect that each response option may have on various species, habitats and socio-economic sensitivities. Its application will ensure that the response strategies implemented will minimise the overall impact on the environment.

6.5.5.2 Review of impacts

Dispersant application

For some of the spill categories, the oil spill response at sea may require the application of dispersant. Other alternatives, which include the use of booms and skimmers, have negligible environmental impacts, but typically only recover small volumes of oil. VOGA has conducted OSTM to assess whether dispersant application provides any potential reduction in impacts from an oil spill.

The effectiveness of chemical dispersant application is reviewed in the Wandoo Field OSCP [WAN-2000-RD-0001] and the impacts of application of chemical dispersant versus the impacts of non-application of dispersant are assessed in Table 5-16, Table 5-17 and Table 5-18 of this EP.

Chemical dispersant will only be applied when the IAP decision-making process has determined that its application will have a net environmental benefit. Once the decision to apply chemical dispersant has been supported by the SIMA process, VOGA will mount an ongoing aerial and marine operation to apply chemical dispersant within the primary zone of application (as defined in Figure 5-23) to allow maximum time for dispersal, thereby reducing the likelihood of shoreline impacts.

The primary zone of application of chemical dispersant is an area of low biodiversity and in relatively deep water. Given the environmental sensitivities within the EMBA, the use of dispersants as an offshore response strategy will potentially minimise impacts on the ecosystems and reduce the need for extensive shoreline clean-up and remediation. A slightly negative impact is likely on the local offshore fisheries of the region, but its significance will largely depend on the extent and duration of a spill.

Key management controls for dispersant application documented in Performance Standard: ELEMENT 8 – OIL SPILL RESPONSE (WAN-WNAB-CP-ER-02 and WAN-WNAB-CP-ER-03) (Appendix 5) are as follows:

- Use of OSCA Register approved dispersants;
- The Dispersant Application Zone in place (Figure 6-6) based on criteria that exclude dispersant being applied in the vicinity of submerged sensitive receptors;
- Chemical dispersant will only be applied when the IAP decision-making process has determined that its application will have a net environmental benefit as part of SIMA process;
- Monitoring of dispersant effectiveness as part of OSMP; and
- Monitoring of marine fauna as part of OSMP and dispersant not sprayed in vicinity of marine fauna.

Other response strategies

The impacts associated with the remaining response strategies are already within the scope of the day-to-day operational support activities (such as logistics), or are no greater than the impact of the spill itself.

In consideration of all these factors, risk management of the proposed oil spill response activities is considered to be ALARP because:

- the incident action planning process is documented and allows for the selection of oil spill response strategies that achieve a net environmental benefit;
- the incident action planning process is continually reviewed to ensure that the outcomes from the response strategies are providing a net environmental benefit;
- the effectiveness of the oil spill response strategies are monitored, and the results are considered in the review and adjustment phases of the incident action planning process;
- the response strategies are consistent with those outlined in the National Marine OSCP (AMSA, 2011b);
- the response strategies are internationally accepted and were proven successful in recent industry-based spill events.

6.5.6 Acceptability demonstration

These risks are considered to be acceptable due to:

- Response actions in an oil spill response are aimed at reducing the environmental impact post oil spill;
- During a spill response the expectation on the titleholder is to implement their OSCP to mitigate the environmental impact of the spill. The potential impact to environmental sensitivities outlined in Section 3 has been assessed and measures have been incorporated into the Wandoo Field OSCP;

The arrangements within the Wandoo Field OSCP are in line with the National Plan and pre-empt the environmental management requirements within by establishing environmental controls and performance criteria that:

- considers potential spill impact;
- considers the potential impact of the response strategies;
- considers environmental sensitivities as outlined within this EP and their prioritisation based on recovery rates and sensitivity;
- Effectiveness of response strategies will be assessed, and response actions will be adjusted to ensure acceptable outcomes;
- Consultation, notification and cooperation with stakeholders during the planning and implementation of spill response activities ensures that the activities are acceptable to external stakeholders, conducted in accordance with relevant legislation and in cooperation with existing plans relating to spill response in State and Commonwealth waters (e.g. AMOSC Plan, NatPlan, WestPlan-MOP); and
- Operational hazards are in line with common marine hazard around the world, with a low frequency, and the controls and performance monitoring identified in this Wandoo Facility EP meet or exceed those typically applied for global marine operations.

6.6 Diesel spill to sea

6.6.1 Hazard report

Table 6-35: Hazard report – Diesel spill to sea

HAZARD:	Diesel spill to sea					
EP risk no.:	EP-OP-R05					
Potential impacts:	Loss of diesel of up to 700m ³ .					
PREVENTION:						
Activity/cause:	Existing management controls	Control type	Control hierarchy	Performance outcome	Performance standard	Measurement criteria
Loss of diesel from support/bunkering vessel caused by collision with another vessel or the Facility.	Navigational lights on vessels.	Engineering	Reduction	Reduce the risk of diesel release to sea from vessel collisions.	Vessels remaining in the field during hours of darkness comply with navigation lighting requirements.	Wandoo Marine Operations Checklist.
	Permission required for field entry, mooring-up and departure.	Administrative	Reduction		Vessels comply with permissioning protocols for vessels entering the field, mooring-up and departure, as per the Wandoo Marine Operations Manual [WNB-1000-YV-0001].	Wandoo Marine Operations Checklist.
	Station keeping requirements for vessels.	Administrative	Reduction		Dynamic positioning requirements, as per Section 9 of the Wandoo Marine Operations Manual [WNB-1000-YV-0001].	Wandoo Marine Operations Checklist.
	Speed limit for all vessels inside Wandoo restricted zone.	Administrative	Reduction		Vessels comply with 500m restriction zone speed limits, as per the Wandoo Marine Operations Manual [WNB-1000-YV-0001].	Wandoo Marine Operations Checklist.
	Vessel operations restricted in adverse weather.	Administrative	Reduction		Vessel operations restricted in adverse weather, as per the Wandoo Marine Operations Manual [WNB-1000-YV-0001].	Wandoo Marine Operations Checklist.
Diesel spill caused by hose rupture during bunkering.	Vessel pump rating	Engineering	Reduction	Reduce the risk of diesel release to sea from bunkering hose rupture.	Bunkering hose changed out annually and maintained/inspected as per planned maintenance task which covers hose replacement and pressure testing of hoses/ fittings.	Maintenance records.
	Breakaway coupling along hose to prevent spill due to vessel loss of position.	Engineering	Reduction		Pressure rating of the diesel hose exceeds the maximum pressure from the vessel pump.	Wandoo Marine Operations Checklist.
	Bunkering procedure.	Administrative	Reduction		Breakaway coupling to part prior to bunker hose tensile failure.	Breakaway Coupling Specification Hose design specifications
	Station keeping requirements for vessels.	Administrative	Reduction		Refuelling activities undertaken as per the bunkering procedure within the Platform Operations Manual (VOG-7000-MN-0001)	Wandoo Diesel Bunkering Report
Potential overflow from pedestal tank or day tanks or rupture of diesel distribution network.	Crane pedestal has level alarms.	Engineering	Reduction	Reduce the risk of diesel spills to sea from over-filling the crane pedestal.	Crane pedestal inspection and maintenance includes level alarm testing.	Maintenance records.



MITIGATION:					
Existing management controls	Control type	Control hierarchy	Performance outcome	Performance standard	Measurement criteria
SOPEP for vessels addresses potential spill response.	Administrative	Mitigation	Mitigate the environmental impact of a diesel spill to sea by implementing appropriate spill response strategies to achieve the best environmental outcome.	SOPEP covers loss of diesel to sea.	Assurance records,
Wandoo Emergency Response Plan [VOG-2000-RD-0017].	Administrative	Mitigation		The Wandoo Emergency Response Plan [VOG-2000-RD-0017] shall meet the performance criteria as per WAN-WNAB-CP-ER-01 – Emergency preparedness, managements and response	Assurance criteria as per WAN-WNAB-CP-ER-01 - Emergency preparedness, managements and response.
Oil spill response arrangements	Administrative	Mitigation		Performance criteria, as per WAN-WNAB-CP-ER-02; WAN-WNAB-CP-ER-03, WNAB-CP-ER-01-05 and WNAB-CP-ER-01-06 (refer to Hazard EP-OP-R01 Table 6-2)	Assurance activities, as per WAN-WNAB-CP-ER-02; WAN-WNAB-CP-ER-03, WNAB-CP-ER-01-05 and WNAB-CP-ER-01-06
INITIAL RISK WITH EXISTING CONTROLS:					
Consequence		Likelihood (of consequence)		Initial risk	
Moderate (3)		Unlikely (B)		Medium	
ADDITIONAL CONTROLS/DEMONSTRATION OF ALARP - VOGA WORKSHOP:					
Medium risk is defined as tolerable on demonstration of ALARP under the VOGA risk level action criteria. The following ALARP analysis provides assurance that all risk treatment options have been considered.					
Additional management controls		Assessment		Adopted/Not adopted	
Refer to Section 6.2.7 for oil spill response ALARP evaluation tables.					
Reduction in diesel inventory		Reducing a support vessel's diesel inventory would require diesel bunkering to be carried out more frequently, resulting in increased potential for collision, increased risk of release during bunkering, and additional fuel usage and costs.		Not adopted	
Smaller vessels (therefore smaller fuel tank sizes) to support operations		The support vessel class/size is selected based on the requirements to support the Wandoo operations. Selecting smaller vessels based on the potential spill volume risk is not feasible, as the vessel must be fit for purpose.		Not adopted	
RESIDUAL RISK AFTER ADDITIONAL CONTROLS:					
Consequence		Likelihood (of consequence)		Residual risk	
Moderate (3)		Unlikely (B)		Medium	
ACCEPTABLE LEVEL OF RISK DEMONSTRATED:					
Principles of ESD not compromised	External Context – objects or claims considered	Internal Context – VOGA HSE / procedures met	Other Requirements met	RR < High (RRII)	EPO(s) manage risk to acceptable level(s)
Relevant principles of ESD not compromised given proposed controls	N/A – no external objections or claims received	Yes – Risk managed in accordance with VOGA HSE policy and bunkering procedures. Potential spills to be managed in accordance with Wandoo Emergency Response Plan [VOG-2000-RD-0017]/Wandoo Field OSCP [WAN-2000-RD-0001].	Potential spills to be managed in accordance with SOPEP/ SMPEP (equivalent to class).	Yes – RR = RRIII (Medium)	Yes – EPOs specify no diesel spills to marine environment. The following relevant overarching EPOs (Section 3.4) maintained providing control measures maintained: EPO-OP-01; EPO-OP-03; EPO-OP-04; EPO-OP-05; EPO-OP-06; EPO-OP-07; EPO-OP-08; EPO-OP-09; EPO-OP-10; EPO-OP-11; EPO-OP-12; EPO-OP-13; EPO-OP-16; EPO-OP-17; EPO-OP-18; EPO-OP-19; EPO-OP-20

6.6.2 Description of hazard

Diesel is bunkered onto the facility from a supply vessel and stored in Shaft 2 before being transferred into the pedestal tank. The main potential causes of loss of diesel include:

- Loss of diesel from the diesel bunkering vessel (or any other vessel) caused by collision with another vessel or the Facility;
- Diesel spill caused by hose rupture during bunkering operation; and
- Potential overflow from pedestal tank or day tanks, or rupture of diesel distribution network.

The maximum credible spill scenario due to a vessel collision is the loss of the largest fuel tank (AMSA, 2013). The anticipated total volume of diesel that may be stored, within multiple internal tanks, by a support vessel is 2,325m³. The maximum volume of the single largest fuel tank (based upon 100% capacity) aboard a support vessel is generally <300m³. A volume of 300m³ was therefore considered as the maximum volume of diesel that could be spilled.

For conservatism in the assessment of impact, the maximum spill extent of 150km in the NERA Reference Case was used, which is based on a diesel spill volume of up to of 700m³.

In the case of a release from the hose during diesel transfer, the estimated maximum spill volume that may occur is 10m³. This is based on a maximum flow rate of 110m³/hr from the hose and assumes that refuelling would be shut down within 5 minutes of notification of fuel loss. This is the conservative time taken to identify the spill and shut down the bunkering operation. This scenario was not identified as a worst-case spill scenario.

A diesel spill on the Facility may also occur due to a pipe rupture or fracture at the bottom of the pedestal tank. If this occurs, the maximum volume of diesel released will be 64m³. Diesel overflow from the crane pedestal to the environment is not likely however as it has an overflow line to Shaft 2 and a high-level alarm. This scenario was not identified as a worst-case spill scenario.

6.6.2.1 Hazard management

Loss of diesel due to vessel collision (700m³ of diesel)

Controls to manage the hazard of a support vessel collisions with the platform or another vessel include:

- Navigation aids on vessels;
- Management systems (500m restricted zone, weather restrictions, speed limits); and
- Station keeping requirements

Hose rupture (10m³ of diesel)

Controls to prevent of hose rupture include:

- Pre-start testing of hose to identify potential failure in advance, as per the bunkering procedure;
- Providing dry breakaway couplings to limit the potential of a hose section breaking on dynamic loading; and

- Refuelling is undertaken only during periods of calm weather and in daylight hours or at night-time using artificial lighting to allow full hose to be visible and leaks to be detected as per the bunkering procedure.

6.6.3 Impact assessment

6.6.3.1 Sensitive receptors

Potential impacts to sensitive receptors in the unlikely event of vessel to vessel collision resulting in a fuel tank rupture are described in the National Energy Resources Australia (NERA) Consequence Analysis of an Accidental Release of Diesel Reference Case (NERA, 2018). This Reference Case is considered relevant to the risk described for this activity given that:

- Water depths within the Permit Area are greater than 10 m (i.e. 50 m).
- Accidental release volume is <math><700\text{ m}^3</math> (i.e. 300 m³).
- Fuel type is marine diesel (i.e. consistent with hydrocarbon characteristics within the Reference Case).
- Other variables, including air temperature, release duration and consequence thresholds are consistent within those used in the Reference Case's impact analysis.

The modelling results for the Reference Case demonstrated that there was no surface impact above thresholds beyond 150 km from the source of the spill. The models also showed that entrained concentrations above thresholds generally travelled with the prevailing currents which tend to oscillate and run longitudinally to coastlines. Entrained hydrocarbons > 500 ppb (threshold) are expected at the release point and can extend beyond 150 km from the release site.

However, while sub-surface entrained and dissolved hydrocarbons may travel beyond 150 km from the immediate discharge location, most of the models showed the greatest concentration of hydrocarbons remained within the top few metres of the water column and closer to the release site.

Given that the greatest concentrations of hydrocarbons remain in the top few metres, shoals and reefs, and demersal fauna located in waters below 10 m water depth are unlikely to be affected by entrained and dissolved hydrocarbons.

Based on the limited offshore area exposed by moderate levels of hydrocarbons, the sensitive receptors are limited to plankton and transient fish (pelagic), marine mammals, marine reptiles and seabirds.

6.6.3.2 Impact description

Marine fauna

The extent of surface water hydrocarbon exposure has the potential to cause injury and mortality through toxicity poisoning to an intersecting individual marine receptor (such as seabirds, marine turtles or marine mammals):

Seabirds dive in ocean waters to feed or rest at the surface. In the event that seabirds are exposed to hydrocarbons, these behaviours will oil feathers breaking down thermal insulation and buoyancy properties of seabird plumage which prevents them from feeding or flying (Crawford et

al., 2000). Seabird preening of oiled feathers will result in oil ingestion and resultant gut damage (Crawford et al., 2000). Oiling of seabird feathers may result in mortal injury through starvation, cold and poisoning. Breeding BIA for the Wedge-tailed Shearwater is present within 150km of the release site, however, it is noted that the BIA intersected is the buffer zone around a breeding island (i.e. not the breeding location itself). A study tracking movements of wedge-tailed shearwaters indicate that birds forage on average 85 km away and up to a maximum of approx. 185 km from their nesting site, over short trips of 1-3 day duration (Cecere et al 2013).

Marine turtles have the potential to ingest oil by surface breathing within the slick or consuming contaminated prey species. Ingestion of oil may result in mortal injury from damaged digestive function (Milton and Lutz 2003). Flatback turtle internesting BIA is present within 150km of the release site however no known aggregation areas are present / nor have the potential to be exposed to hydrocarbons from this event.

Surfacing marine mammals such as blue whales and humpback whales migrating through surface hydrocarbon exposures are susceptible to fume inhalation and oil absorption through the skin (Helm et al., 2015). Physical contact by individual whales of MDO is unlikely to lead to any long-term impacts (Fraker, 2013). Given the mobility and wide geographical distribution of whales on the NWS, only a small proportion of the population would be expected to surface in an area exposed to surface hydrocarbons, resulting in short-term and localised consequences, with no long-term population viability effects (Helm et al., 2015). Geraci (1988) found little evidence of cetacean mortality from hydrocarbon spills; however, some behaviour disturbance (including avoidance of the area) may occur. While this reduces the potential for physiological impacts from contact with hydrocarbons, active avoidance of an area may disrupt behaviours such as migration.

The extent of in-water hydrocarbon exposure has the potential to cause chronic impacts to planktonic organisms, pelagic fish and marine mammals that might move within the plume.

Plankton are drifting organisms which includes eggs and larvae of fish and other animals. Plankton species are sensitive to toxic effects of oil at low concentrations and large numbers of planktonic organisms may be affected (ITOPF, 2011). Plankton are numerous and widespread but do act as the basis for the marine food web. However, any impact is expected to be localised and temporary, meaning that an oil spill in any one location is unlikely to have long-lasting impacts on plankton populations at a regional level. Once background water quality conditions have re-established, the plankton community may take weeks to months to recover (ITOPF, 2011). The potential impacts to plankton are expected to be short-term, localised, and not affecting local ecosystem functioning.

Pelagic free-swimming fish and sharks are unlikely to suffer long-term damage from oil spill exposure because dissolved/entrained hydrocarbons in water are not expected to be sufficient to cause harm (ITOPF, 2011). Subsurface hydrocarbons could potentially result in acute exposure to marine biota such as juvenile fish, larvae, and planktonic organisms, although impacts are not expected cause population-level impacts. A proportion of the foraging population of whale sharks could be affected, which could result in temporary and localised consequences.

Cetacean exposure to in-water hydrocarbons can occur via ingestion or physical coating (Geraci and St Aubin, 1988). The potential for environmental impacts would be limited to a relatively short period following the release and would need to coincide with a migration or aggregation event to result in exposure of a large number of individuals. However, such exposure is not anticipated to result in long-term population viability effects. A proportion of the migrating

population of whales could be affected for a single migration event, which could result in temporary and localised consequences.

Tainting of seafood can occur rapidly with even very low concentrations of hydrocarbons in the water. Tainting is where fish/shellfish absorb hydrocarbon from the water and its flesh has an oil odour or flavour when eaten. Tainted fish will be unacceptable to the market and may need to be dumped. If left in clean water for a few weeks the tainting will gradually disappear (NERA 2018:1003).

Given that the potential for hydrocarbon exposure within 150km of the release site is relatively short-term (up to 144 hours), receptors may be exposed resulting in potential localised consequences. It is unlikely that many marine receptors will be exposed and therefore no receptor populations will be affected.

In the event a vessel collision would result in the release of diesel, marine fauna casualties may result however would only occur at a localised level (given the limited duration and transient nature of receptors within the area) and would be unlikely to impact local populations. This event is expected to result in localised, short-term impacts to transient marine receptors.

The potential impacts of spill response activities are discussed in Section 6.5

6.6.4 Oil spill response strategies (mitigation)

Sections 6.5 and 7.9 summarise the process undertaken to mitigate the hazard scenarios described and assessed in Sections 6.6.2 and 6.6.3 respectively. To support a hazard based approach to planning, oil spill scenarios outlined in this EP were grouped into spill categories based on fluid type, duration and volume. The spill category which covers this hazard is 'B'

An assessment of the benefits of the oil spill response strategies that are considered feasible to respond to this spill are provided in Table 6-36. The response strategies not considered feasible are outlined in Table 6-36.

The hazards, impacts and the controls required to manage the environmental impact of the oil spill response strategies are outlined in Section 6.5. The impacts of the response strategies were considered in the strategy selection process.

Table 6-36: Feasibility and benefits of response strategies for a Category B spill

Oil spill response strategy	Feasible	Benefits
Source control	Yes	Source control activities include shutting off pumps and transferring fuel to another fuel tank. All strategies would be effective in minimising the amount of diesel lost to the environment and would reduce the area of potential exposure.
Monitor and evaluate	Yes	Monitoring and evaluation provides information on the behaviour and likely trajectory of the spill. This will be used to evaluate the appropriate response strategy.

Oil spill response strategy	Feasible	Benefits
Mechanical dispersion	Possible	Mechanical dispersion assists with the natural dispersion process, encouraging the slick to mix and suspend within the water column where it can be more easily biodegraded. Once dispersed in the water column, the smaller droplet size enhances the natural biodegradation process. It may be used to assist chemical dispersion when sea conditions are calm. Used when surface oil presents a greater risk to the marine environment than entrained oil.
Oiled wildlife response	Possible	This is applicable for marine fauna that come close to the spill or become oiled. Care is to be taken not to injure animals or drive animals into the spill, or split up the pods, schools and flocks.

The response strategies will be implemented in accordance with the Wandoo Field OSCP [WAN-2000-RD-0001].

Table 6-37: Response strategies not considered feasible for a Category B spill

Oil spill response strategy	Feasible	Considerations
Containment and recovery	No	The effectiveness of containment and recovery depends on the thickness of the hydrocarbon, and weather and sea state conditions. As diesel is a volatile non-persistent hydrocarbon, it is easily spread by wind and wave action. The ability to contain and recover spreading diesel on the ocean is extremely limited, hence this response strategy is not considered effective in reducing the net environmental impacts of the spill.
Chemical dispersion	No	Marine diesel is not considered to be a persistent hydrocarbon; it has a high natural dispersion and evaporation rate. Modelling results predict that approximately 70% of the diesel will have evaporated after 30 days and the majority of the remaining 30% will become entrained in the water column. Chemical dispersant application is not recommended as a beneficial option for diesel, as it has a low probability of increasing the dispersion rate of the spill while introducing more chemicals to the marine environment.
Protection and deflection	No	Protection and deflection can be used to protect sensitive receptors through the use of booms to create physical barriers on the water surface. The effectiveness of protection and deflection depends on the thickness of the hydrocarbon, and weather and sea state conditions. As diesel is a volatile, non-persistent hydrocarbon easily spread by wind and wave action, the ability to corral marine diesel is extremely limited. Modelling results also predict that this spill has a low probability of shoreline contact. Hence it is unlikely that protection and deflection will be used in this case.
Shoreline clean-up	No	Shoreline clean-up is unlikely to be used as shoreline contact is not predicted.

Oil spill response strategy	Feasible	Considerations
In-situ burning	No	Is not considered feasible as diesel has not been proven to be amenable to in-situ burning. Also, the required equipment technology and training are not available in Australia for operators using this technique.

6.6.5 Risk ranking

6.6.5.1 Consequence

Loss of diesel due to vessel collision (700m³ of diesel)

The volume of the largest vessel cell in the most commonly used vessel is 102m³. A precautionary approach was applied, increasing the volume of a potential spill to 700m³. Therefore as per the discussion in Sections 6.6.2 and 6.6.3 a consequence ranking of '3' (Moderate) was considered appropriate.

Hose rupture (10m³ of diesel)

A conservative approach for the time taken to identify a spill during bunkering and to shut down the operation was taken. Therefore as per the discussion in Sections 6.6.2 and 6.6.3 a consequence ranking of '2' (Minor) was considered appropriate.

6.6.5.2 Likelihood

The probability of collisions involving visiting vessels is 2.87E-04 per year for WNB (Wandoo Safety Case: WNB-1000-YH-0001); this probability doesn't consider impact strength and probability of hydrocarbon release. A likelihood ranking of "B: Unlikely" has been applied as impact energies required to generate release are at the lower end.

As identified in the WNB Flammable Hazards Analysis [WNB-3000-RH-0013] the likelihood of a release from a flexible line is 6E-03. Therefore, a likelihood ranking of "C: Possible" is appropriate.

6.6.5.3 Residual Risk ranking

This results in risk levels of:

- 3B –Medium risk for Loss of diesel due to vessel collision; and
- 2C – Medium risk for Hose rupture.

The worst case residual risk ranking for this environmental hazard to sea is therefore Medium (RRII).

6.6.6 ALARP demonstration

6.6.6.1 Overview

Diesel is the power source for several critical functions in the Wandoo Field, including marine vessels, turbines, cranes and combustion engines. The ALARP assessment has concluded that the risks are being managed to ALARP because:

- There are sufficient layers of protection in place for the current risk level; and
- Additional controls and alternative arrangements were not considered to be practical due to the associated increase to other risks.

6.6.6.2 Existing controls

The hazard summary in Section 6.6 describes the controls for this hazard. The range of controls includes multiple independent layers of protection, including:

- Where reservoir conditions permit, natural gas from the reservoir (which has no spill risk), is used for the turbines in preference to diesel, reducing overall diesel requirements;
- Controls relating to marine activity to reduce frequency of collisions;
- Engineering and administrative controls to reduce the frequency of release during bunkering; and
- High level alarms and overflow on the diesel day tanks to prevent overflow to sea.

6.6.6.3 Spill response

The response strategies to reduce the environmental impact are from this hazard scenario are outlined 6.6.4 and are implemented through the Wandoo Field OSCP [WAN-2000-RD-0001]. VOGA has a spill preparedness planning process that identifies suitable spill response strategies which:

- Is consistent with the hazard profile;
- VOGA's response strategies and procedures to reduce the volume of hydrocarbons spilt and reduce the environmental impact are outlined in the Wandoo Field OSCP [WAN-2000-RD-0001]. These response strategies are consistent with those outlined in the National Plan;
- Considers the benefits of each strategy as outlined in Sections 6.6.4; and
- Considers the risks and impacts of each strategy as outlined in Section 6.5.

The spill response planning process is described in Section 7.9.2.2 and results in spill response which will best mitigate the environmental impacts of this hazard scenario.

A full explanation on the process to review response and capability requirements to support managing spill risks to ALARP is provided in Section 6.2.7.

6.6.6.4 Additional controls and alternative arrangements

VOGA carried out an assessment of alternative arrangements and additional controls to reduce risks. An alternative arrangement for diesel delivery was identified. The potential impact of a diesel spill could be decreased by reducing the supply vessel's diesel inventory. This alternative was rejected as this would require diesel bunkering to be carried out more frequently, thus:

- Increasing vessel movements with associated increased collision and spill frequency;
- Increased risk of release during bunkering; and
- Increasing additional fuel usage and cost.

No additional controls were identified.

6.6.6.5 Conclusion

The ALARP assessment has concluded that the risks are being managed to ALARP because:

- There are sufficient layers of protection in place for the current risk level;
- In the unlikely event of a diesel spill, response strategies which match the hazard profile are defined in the Wandoo Field OSCP [WAN-2000-RD-0001] and will be implemented to reduce the impact of the spill to the environment. The resources to implement the response has been determined and evaluated to ensure that the response strategies can be achieved; and
- Additional controls and alternative arrangements were not considered to be practical due to the associated increase to other risks.

6.6.7 Acceptability demonstration

These risks are considered to be acceptable:

- As bunkering and vessel operations is a common marine hazard around the world with a low incident frequency, and the controls and performance monitoring identified in this Wandoo Facility EP meet or exceed those typically applied for global marine operations;
- As the alternative arrangements are not considered practical, increase associated safety and environmental risk, and/or are not sustainable from a cost or environmental impact point of view;
- Ongoing stakeholder consultation undertaken for this Wandoo Facility EP did not generate any feedback regarding concerns due to diesel spills;
- With the preventative and mitigative controls in place, the conservation of biological diversity and ecological integrity shall be maintained; and
- In the event of a hydrocarbon spill, the activities, and the proposed performance management measures, meet the requirements of internal VOGA procedures that have been developed in accordance with relevant environmental legislation.



6.7 Discharge of PFW and ballast water from Facility

6.7.1 Hazard report

Table 6-38: Hazard report – Discharge of PFW and ballast water from Facility

HAZARD:	Discharge of PFW and ballast water from Facility					
EP risk no.:	EP-OP-R06					
Potential impacts:	Toxicity effects to marine organisms from OIW and chemicals (biocide, corrosion inhibitor, water clarifier, scale inhibitor, oxygen scavenger) in PFW and ballast water. Decline in water quality associated with lowered dissolved oxygen concentrations as a result of elevated water temperature.					
PREVENTION:						
Activity/cause	Existing management controls	Control type	Control hierarchy	Performance outcome	Performance standard	Measurement criteria
Planned PFW discharge.	OIW concentration monitored and alarmed in the MCS.	Engineering	Reduction	No impact to the marine environment outside the PW mixing zone boundary of 256 dilutions (3.7km).	High and high-high OIW alarm set.	Calibration records of inline OIW analyser.
		Administration	Reduction		OIW performance shall be reported internally and reviewed daily.	Wandoo daily report.
		Engineering	Reduction		In the event the inline OIW analyser is out of service, manual OIW analysis shall be undertaken six times per day.	OIW test records
		Engineering	Reduction		Deviation of inline OIW analyser results from manual OIW analysis results will be managed in accordance with Table 6-44 of this EP	OIW test records
	PFW discharge overboard can be diverted inboard.	Engineering	Reduction		OIW levels are monitored so as to not reach unacceptable 24-hour OIW limits.	24-hour inline OIW analyser records. Recordable incident reports for Unacceptable Limit exceedances
	PFW discharge flow rates are monitored.	Engineering	Reduction		Discharge flow rate shall be monitored and maintained such that maximum limits are not exceeded.	Wandoo daily report.
	Routine external laboratory testing to ensure PFW chemistry is within assumed levels.	Engineering	Reduction		A PFW representative sample shall be sent to a National Association of Testing Authorities (NATA) accredited laboratory on a monthly basis for OIW analysis to confirm accuracy of daily measurement methodology.	Laboratory analysis records.
		Engineering	Reduction		PFW chemistry monitoring is undertaken on a yearly basis, or more frequently if required, as outlined in Table 6-44.	Laboratory analysis records.
		Engineering	Reduction		The toxicity of an end-of-pipe PFW sample is assessed on a two yearly basis, or more frequently if required, as outlined in Table 6-44.	Laboratory analysis records.
	Chemical dosing concentrations are monitored.	Administration	Reduction		Chemical dosage concentrations remain within defined limits, as outlined in Table 3-7 of this EP.	Chemical dosage concentrations and rates recorded in the weekly chemical stocktake.
	Chemical assessment and selection process.	Administration	Reduction		Chemicals used in the production process that will be discharged to the marine environment are selected in accordance with the chemical assessment process.	Chemical assessment records. Assessment of existing chemicals is outlined in the review of current process chemicals.
		Administration	Reduction		Incumbent process chemicals NICNAS registration and OCNS substitution warnings will be reviewed annually.	Review records.



Activity/cause	Existing management controls	Control type	Control hierarchy	Performance outcome	Performance standard	Measurement criteria
Process upsets.	Instrument protective and alarm systems (interface level low level trips in production and second stage separators).	Engineering	Prevention		Level transmitters in production and second stage separators are maintained	Maintenance records
	Produced Water Adaptive Management Strategy [WNB-7000-RP-0010].	Administration	Reduction		Produced Water Adaptive Management Strategy [WNB-7000-RP-0010] outlines a process to identify and record OIW excursions	Causes for OIW excursions are reviewed as per the Produced Water Adaptive Management Strategy [WNB-7000-RP-0010].
Planned discharge of ballast water.	OIW concentration monitored and alarmed in the MCS.	Engineering	Reduction		High and high-high OIW alarm set.	Calibration records of inline OIW analyser.
		Administration	Reduction		OIW performance is reported internally and reviewed daily.	Wandoo daily report.
		Engineering	Reduction		In the event the inline OIW analyser is out of service, manual OIW analysis will be undertaken (twice daily during normal operations, six times daily if diverting PFW inboard).	OIW test records.
				Deviation of inline OIW analyser results from manual OIW analysis will shall be managed in accordance with Table 5-70 of this EP.	Monitoring of ballast water discharge of OIW via daily laboratory checks.	
	Ballast water discharge overboard can be deferred to allow for fault finding.	Engineering	Reduction		OIW levels are shall be monitored via the 24-hour OIW inline OIW analyser so as to not reach unacceptable 24-hour OIW limits.	24-hour OIW inline OIW analyser records.

MITIGATION:

Existing management controls	Control type	Control hierarchy	Performance outcome	Performance standard	Measurement criteria
None identified.	N/A	N/A	N/A	N/A	N/A

INITIAL RISK WITH EXISTING CONTROLS:

Consequence	Likelihood (of consequence)	Initial risk
Incidental (1)	Almost Certain (E)	Medium risk

ADDITIONAL CONTROLS/DEMONSTRATION OF ALARP - VOGA WORKSHOP:

A Medium risk is defined as tolerable on demonstration of ALARP under the VOGA risk level action criteria. The following ALARP analysis provides assurance that all risk treatment options have been considered.

Additional management controls	Assessment of option	Adopted/not adopted
Transport PFW to shore via vessel	Disposal of PFW to a vessel tank would result in zero PW disposal to the marine environment PW volumes per day are vastly in excess of vessel storage and would require many vessels operating on a 24 hour basis between the FPSO and shore. This presents additional risks (e.g. spill risk, vessel presence, discharge). High cost of multiple vessels on contract. Additional environmental risks outweigh the environmental benefits.	Not adopted
Drill PW reinjection wells	Will allow PW to be re-injected into a well rather than be discharged to the marine environment Drilling a re-injection well and installation of required water injection equipment is cost prohibitive and will pose other environmental impacts / risks (cuttings discharge, oil spill risk).	Not adopted

RESIDUAL RISK AFTER ADDITIONAL CONTROLS:

Consequence	Likelihood (of consequence)	Residual risk
Incidental (1)	Almost Certain (E)	Medium risk



ACCEPTABLE LEVEL OF RISK DEMONSTRATED:					
Principles of ESD not compromised	External Context – objects or claims considered	Internal Context – VOGA HSE / procedures met	Other Requirements met	RR < High (RRII)	EPO(s) manage risk to acceptable level(s)
Relevant principles of ESD not compromised given proposed controls	N/A – no external objections or claims received	Yes – Impact managed in accordance with VOGA HSE policy and Produced Water Adaptive Management Strategy [WNB-7000-RP-0010]	Yes – VOGA chemical assessment process aligns with OPSAR, OCNS and IFC guidance.	Yes –RRIII (Medium)	Yes – EPOs specify no impact to the marine environment outside the PW mixing zone boundary. The following relevant overarching EPOs (Section 3.4) maintained providing control measures maintained: EPO-OP-01; EPO-OP-04; EPO-OP-05; EPO-OP-06; EPO-OP-07; EPO-OP-08; EPO-OP-09; EPO-OP-10; EPO-OP-11; EPO-OP-12; EPO-OP-13

6.7.2 Description of hazard

6.7.2.1 Overview

Water naturally present in the reservoir from which the hydrocarbons are extracted is treated, processed and discharged as PFW. The composition of the PFW varies from field to field but PFW typically contains concentrations of petroleum hydrocarbons, alkylphenols, organic acids, metals, radioisotopes, and residual process chemicals.

Process chemicals such as corrosion and scale inhibitors, biocides and water clarifiers are added at various stages of the production process.

Water is also used to ballast the Facility during hydrocarbon export. As oil is exported, ballast water automatically flows from Shaft 4 to the CGS compartments via the buffer cell to replace the exported oil.

Ballast water from the Facility may contain some oily water from the interface zone in the CGS. Due to decline in production rate over time, the residence time of ballast water in the CGS has increased, allowing for sufficient oil-water separation within the CGS without the requirement for further processing.

6.7.2.2 Current hazard description

Produced formation water

Up to 32,000m³ of PFW is currently discharged per day. PFW is continuously monitored for OIW content to ensure it is within specification before being discharged overboard. Water within specification is discharged overboard with the ballast water.

Ballast water

Currently, the ballast water is typically kept below 3mg/L with a typical discharge equal to the oil production and an upper discharge rate of 1,500m³/day. The ballast water is discharge overboard with the PFW to form a combined discharge of up to 33,500m³/day and is not included in the PFW average target.

It should be noted that the ballast water discharge rates are not capped and are based on production rates and CGS ballast management requirements.

Ballast water is continuously monitored for OIW content to ensure it is within specification before being discharged overboard. Similar to the management of PFW, operations will not discharge ballast water and/or shutdown production if the OIW exceeds 30mg/L over a 24-hour average.

6.7.2.3 Proposed hazard description

Produced formation water

The proposed upgrade is to manage solids which are impacting on OIW concentrations by improving the process as outlined in Section 2.5.7.8.

The upgrade results in increased processing capacity which can be utilised to increase total fluid production rates, at reduced OIW concentrations.

The composition of the PFW and process chemicals used will remain as for the current flow rate described in this section.

The PFW throughput will be increased in stages until a maximum flow rate of 36,000m³/day is achieved. This will occur via the MoC process when additional processing equipment allows for reduced OIW values at the proposed increased flow rates.

A mass balance approach was used to calculate the OIW concentration for the acceptable and unacceptable limits at each incremental increase in flow rate to maintain a commensurate total volume of oil entrained in the PFW discharged per day. OIW concentrations in the range below the Acceptable Limit, and between the Acceptable and Unacceptable limits are within the mixing zone extent. The Unacceptable limit aligns with an exceedance of the mixing zone, which is considered an unacceptable impact. Both the Acceptable and Unacceptable OIW limits are considered in the impact assessment (Section 6.7.6.) and their purpose in PFW management is outlined in Section 6.7.6.

The proposed OIW concentrations and equivalent PFW flow rates are shown in Table 6-39.

Table 6-39: Acceptable and unacceptable PFW OIWs at proposed flow rate regimes

Flow Rate Regime (Combined PFW and Ballast)	Maximum PFW Flow Rate	Acceptable OIW 24-hour Limit	Unacceptable OIW 24-hour Limit
m ³ /day	m ³ /day	mg/L	mg/L
26,100	24,600	16.7	30.0
28,500	27,000	15.2	25.9
30,500	29,000	14.2	24.2
33,500 (Current)	32,000	12.5	22.0
37,500 (Proposed)	36,000	11.1	19.5

Ballast water

Ballast water will continue to be processed as per Section 6.7.2.2.

The ballast water discharge rates are not capped and are based on production rates and CGS ballast management requirements. The combined PFW and ballast water volumes discharges however will not exceed the 'flow rate regime' volumes listed in Table 6-39. The OIWs acceptable and unacceptable limits will be the same as for PFW.

6.7.2.4 PFW composition

PFW chemistry monitoring is undertaken by a National Association of Testing Authorities (NATA) accredited laboratory every year. The chemical analytes tested include: anions, cations, total dissolved solids, total suspended solids, alkalinity as calcium carbonate (CaCO₃), total recoverable mercury, hexavalent and trivalent chromium, dissolved and total metals/metalloids, BTEX, PAHs, total recoverable hydrocarbons (TRH), total petroleum hydrocarbons (TPH), ammonia and radionuclides.

Exceedances against ANZECC water quality guideline values (ANZECC & ARMCANZ 2000) or background levels may result in toxicity to marine organisms or eutrophication.

Summary details are provided in the following sections. The historic composition analysis results of PFW are detailed in Appendix 4 together with toxicity testing results.

Hydrocarbons

The results for the chemical analysis for petroleum hydrocarbons include PAHs, BTEX, TPH, and TRH.

The last four years of chemical analysis found no detectable concentrations of any of the 16 US EPA priority pollutant PAHs, with the exception of trace amounts of Pyrene (0.2ug/L)

BTEX concentrations have been below their respective LORs for benzene, toluene, ethylbenzene, xylenes, and total BTEX since monitoring began. Benzene, toluene and ethyl-benzene are the only analytes with ANZECC water quality guideline values; all monitoring results are below the 95% and 99% species protection levels (ANZECC & ARMCANZ, 2000).

Total and dissolved metals

Previous to 2014, only total metal analysis was undertaken on PFW samples. In 2014 the testing of dissolved metal concentrations was included to allow for comparison of values against the ANZECC water quality guidelines species protection levels (ANZECC & ARMCANZ 2000), as there are no guidelines for total metals in marine waters.

The dissolved metals and metalloids concentrations were compared against ANZECC water quality guidelines 95% and 99% species protection levels (ANZECC & ARMCANZ, 2000) where applicable. Dissolved arsenic, barium, iron, manganese, selenium and strontium had no guidelines values for comparison.

Dissolved metal analytes have not exceeded the 95% and 99% species protection levels since 2014 with the following exceptions:

- Copper was above 95% and 99% species protection level in 2019 and 2020.
- Hexavalent chromium has exceeded the 95% species protection level, however remained within 99% levels and below the LOR of the testing, since 2014.
- Zinc exceeded the 99% species protection level in 2019 and 2020, however remained within 95% levels and within the LOR of the testing.
- Mercury exceeded the 95% and 99% species protection levels between 2017 and 2019, however remained within the LOR of the testing in 2017 and 2018. The most recent result (2020) exceeded the 99% protection level however was within the 95% level and the LOR.

Alkylphenols

Concentrations of alkylphenols were generally above LORs annually.

Total ammonia

Results of total ammonia analysis have shown that all of the values exceed the 99% and 95% species protection levels outlined in the ANZECC water quality guidelines (ANZECC & ARMCANZ, 2000).

Process chemicals

Production chemicals are routinely added to the PFW for a range of purposes. Chemicals that are routinely added to the water include:

- corrosion inhibitor
- oxygen scavenger
- water clarifier;
- reverse demulsifier;
- scale inhibitor;
- forward demulsifier.

Note that biocide is utilised for inspection and maintenance, including routine pigging prior to offtakes, and is assessed as part of Hazard EP-OP-R15 (Section 6.16)

Radionuclides

Radionuclides are generated during prolonged period of rock or water contact. PFW, having been in contact with rock strata for prolonged periods at elevated temperature and pressure, contains radionuclides (NRPB, 2004). Concentrations of radionuclides have been analysed in Wandoo PFW in 1994, 2008, 2014, 2015, 2016, 2018 and 2019.

6.7.2.5 Toxicity assessment

Direct toxicity assessment (DTA) provides an integrated measure of toxicity using the whole effluent and is also known as a Whole Effluent Toxicity (WET) Assessment or WET testing. The DTA is prescriptive and requires that toxicity be evaluated across a number of species representing four trophic levels. The reason for this approach is that it represents a cross-section of the taxonomic groups (algae, invertebrates, vertebrates) that reside in the marine environment. By using a range of species, the DTA provides a better understanding of the PFW discharge level of toxicity to organisms throughout the receiving environment trophic levels.

The species selected for testing are based on availability, ecological significance, level of sensitivity and their suitability as test organisms. The test species used include a range of local species and a range of life histories including larvae, which are generally considered more sensitive than adult species. The same species are used where possible for every round of testing to allow for comparison of results.

The use of a mixture species in WET testing with a high sensitivity to contaminants and species with sensitivities similar to species found in the NWS ensures that the WET testing undertaken is suitable for the Wandoo PFW. toxicity (Ecotox Services Australasia, 2016b).

Toxicity was routinely tested on PFW in accordance with the requirements of the ANZECC & ARMCANZ 2000 Water Quality Guidelines between 2006 and 2020. The ANZECC & ARMCANZ

(2000) Water Quality Guidelines recommend testing toxicity for a minimum of five species from at least four different taxonomic groups.

This toxicity testing is considered representative of the produced water discharge given that the produced water generated from each well is sourced from the same reservoir, with the same historical composition.

Annual toxicity testing is undertaken to validate the mixing zone defined in this EP. A DTA of the PFW discharge is routinely undertaken every two years, and a screening test every alternative year.

Toxicity identification evaluation

A toxicity identification evaluation (TIE) was performed on the PFW in 2015 to determine which components of the PFW were responsible for causing toxicity within ecotoxicity results.

TIE uses the response of test organisms to detect the presence of toxicants before and after samples undergo a series of chemical manipulations. Chemical manipulations are used to isolate, identify and confirm the causes of sample toxicity.

The 72 hour sea urchin larval development test was performed on the PFW sample before manipulation using zeolite. Zeolite was added to the sample for a contact time of eight hours to determine if toxicity is associated with ammonia. The 72 hour sea urchin larval development test was performed again after ammonia isolation using zeolite. The results of the assessment showed the toxicity of the sample decreased significantly after isolating ammonia, which indicates that the majority of toxicity in the sample is caused by ammonia.

PFW samples were tested for ammonia before treatment to determine the source of ammonia in the WPF PFW. Ammonia levels in these samples were similar to ammonia levels in the discharge, confirming that ammonia levels are directly related to the characteristics of the reservoir.

6.7.2.6 Unplanned releases

PFW and ballast water can also be released from the facility in quantities and composition, different to the planned discharge, during loss of containment events or due to process upsets.

For loss of containment and/or process upsets the volumes/concentrations would be no worse than those levels already assessed in this section for PFW and ballast water in:

- Sections 6.10 and/or 6.20 for production chemicals; and
- Section 6.18 for OIW.

The impact of unplanned releases of PFW through the produced water outlet are therefore considered in these sections.

6.7.2.7 Hazard management

Section 6.7.6 provides a summary of the strategies to manage PFW and ballast water, and any deviations, as described within the Produced Water Adaptive Management Strategy [WNB-7000-RP-0010] and Table 6-44.

6.7.3 Impact assessment

6.7.3.1 Impact assessment methodology

Impact assessment methodology is detailed in Section 3.3.

6.7.3.2 Impact assessment results

The following section summarises the results of detailed analysis undertaken as part of the Produced Formation Water Environmental Impact Assessment (AE15009-VOG-1000-RH-0002).

Whole effluent

The environmental impact of PFW as a whole effluent was determined by calculating the potential area of exposure based on 99% species protection trigger values derived from ecotoxicity testing undertaken in 2017 in accordance with the ANZECC & ARMCANZ Water Quality Guidelines (2000).

Use of the 2017 results are considered the most appropriate for establishment of a defined mixing zone extent and the associated impact assessment given they identified the highest toxicity of the three most recent full DTA ecotoxicity tests since 2015 and therefore provide conservative extents. In addition, the 2017 results are supported by the 2018 and 2020 ecotoxicity screening test results which both showed similar levels of toxicity for the bioassays tested in 2017.

The current flow rate of 33,500 m³/day and the proposed flow rate of 37,500 m³/day have been assessed for impact assessment and comparison of extent (refer Tables 2-1 to 2-3 in Appendix 4). The results summarised in Table 6-40 show the following:

- PFW is diluted to below the threshold within maximum extents of 3.65km and 2.73km² for the current flow rate, and 3.68km and 3.5km² for the proposed flow rate.
- The increases in maximum extents for any season from current to the proposed scenario are not significant, being a 1% (30m) increase in distance and 28% (770m²) increase in area.

Table 6-40: Whole effluent results (95th percentile)

Level of species Protection	Trigger values (% sample)	Dilutions required	Current Scenario (33,500) Distance (& Area)	Proposed Scenario (37,500) Distance (& Area)
99%	0.39	256	3.65km (2.73km ²)	3.68km (3.5km ²)

These extents are considered conservative for the following reasons:

- The modelling is conservative (refer to Section 3.3.2)
- the analysis doesn't account for frequency and duration of time in excess of the threshold value.

Analysis of frequency and duration of exposure

The results of the frequency and duration analysis for the season with the greatest extents (winter) using the conservative modelled dilutions of 275 and 277 (Figures 2-1 to 2-4 in Appendix 4) demonstrate the following:

- The likelihood and duration the PFW concentration exceeds the impact threshold decreases rapidly with increasing distance from the platform.

- PFW concentrations exceeding the threshold are limited to within 600m of the discharge point for over 99% of time for the current and proposed flow rates.
 - PFW concentrations exceeding the threshold for continuous durations of more than 6 hours are limited to within 400 m of the platform for both the current and proposed flow rates.
- The frequency and duration results are considered in the impact assessment in Section 6.7.3.

Hydrocarbons

The current and proposed flowrate, 33,500 m³/day and 37,500 m³/day respectively, were modelled utilising the relevant impact assessment criteria for each oil phase (refer Tables 2-1 to 2-3 in Appendix 4) for both the 'acceptable' and 'unacceptable' OIW concentration limits. Purpose of the assessment was to determine the potential extent of exposure where the OIW concentrations may be above the hydrocarbon thresholds in the vicinity of the platform.

The OIW concentrations used were based on the combined discharge with produced water concentrations at the 'acceptable' and 'unacceptable' OIW concentration limits; and ballast water concentrations of 3 mg/L. A proportion of dissolved oil in the OIW of 20% was used based on results of laboratory testing indicating a maximum of 16%. The proportion of entrained oil was considered to be 100%.

Results are summarised in Table 6-41. Key findings include:

- The dissolved oil OIW concentrations at the Acceptable Limit would be diluted under the threshold within maximum extents of 2.57 km and 490 m² for the current flow rate and 2.58 km and 530 m² for the proposed flow rate.
- The dispersed (entrained) OIW concentrations at the Acceptable Limit would be diluted under the threshold within maximum extents of 2.84 km and 720 m² for the current flow rate and 2.83 km and 690 m² for the proposed flow rate.
- The dissolved oil OIW concentrations at the Unacceptable Limit would be diluted under the threshold within maximum extents of 3.67 km and 3.36 km² for the current flow rate and 3.67 km and 3.31 km² for the proposed flow rate.
- The dispersed (entrained) OIW concentrations at the Unacceptable Limit would be diluted under the threshold within maximum extents of 3.73 km and 4.5 km² for the current flow rate and 3.73 km and 4.43 km² for the proposed flow rate.
- There are only minor differences in maximum extents between the current and proposed flow rates for each oil phase with the largest variation being a 0.3% (10m) increase in distance and 8% (40m²) increase in area.
- OIW concentrations for both oil phases at the Acceptable limit are well within the whole effluent derived mixing zone extent and the concentrations at the Unacceptable limit align with the outer edge of the mixing zone (dissolved oil) and a slight exceedance of 50m (dispersed oil).

Table 6-41: Hydrocarbon component results (95th percentile)

Oil Phase	Level of species protection	Threshold (OIW ppb)	Current scenario (33,500 kL/d)			Proposed scenario (37,500 kL/d)		
			Initial conc (OIW ppb)	Dilutions required	Distance (& Area)	Initial conc (OIW ppb)	Dilutions required	Distance (& Area)
Dissolved	99%	16	2,400 (Acceptable)	150	2.57 km (490m ²)	2,160 (Acceptable)	136	2.58 km (530m ²)
			4,400 (Unacceptable)	275	3.67 km (3.36km ²)	3,900 (Unacceptable)	244	3.67 km (3.31km ²)
Dispersed (Entrained)	PNEC	70.5	12,000 (Acceptable)	170	2.84 km (720m ²)	10,800 (Acceptable)	153	2.83 km (690m ²)
			22,000 (Unacceptable)	312	3.73 km (4.5km ²)	19,500 (Unacceptable)	277	3.73 km (4.43km ²)

Analysis of frequency and duration of exposure

The frequency and duration analysis results for the dilutions required for both oil phases limits and flow rates for the season with the greatest extents for each dilution are shown in Figures 2-1 to 2-8 in Appendix 4. These results demonstrate the following:

- The likelihood and duration the OIW concentrations for both oil phases remain above the impact threshold decreases rapidly with increasing distance from the platform.
- Dissolved and dispersed oil OIW concentrations at the Acceptable Limit exceeding the threshold are limited 99% of the time to within approximately 300m of the discharge point for both the current and proposed flow rates. Continuous durations of 6 hours or more above the threshold are limited to within approximately 200m.
- Dissolved and dispersed oil OIW concentrations at the Unacceptable Limit exceeding the threshold for 99% of the time are limited to within approximately 600m of the discharge point for both the current and proposed flow rates. Continuous durations of 6 hours or more above the threshold are limited to within approximately 400m.
- There are only minor differences in maximum extents between the current and proposed flow rates for each oil phase.

Ammonia

Ammonia at the current flow rate (33,500 m³/day) and proposed flow rate (37,500 m³/day) at an ammonia concentration of 42 mg/L was modelled to determine the area of exposure with results shown in Tables 2-1 to 2-3 in Appendix 4.

The impact assessment criteria used to determine the area of exposure was the ANZECC (2000) 99% species protection level.

The results summarised in Table 6-42 show the following:

- Ammonia is diluted under the impact threshold for the current flow rate within 500m of the platform, and within 700m for the proposed flow rate.
- The increase in maximum extents for any season from current to the proposed scenario are not significant, being a 40% (200m) increase in distance and 45% (31m²) increase in area.

Table 6-42: Ammonia component results

Level of species protection	Initial Conc (mg/L)	Threshold (Final Conc)	Dilutions required	Current Scenario (33,500) Distance (& Area)	Proposed Scenario (37,500) Distance & (Area)
99%	42	0.5	84	490m (69m ²)	690m (100m ²)

Analysis of frequency and duration of exposure

The results of the frequency and duration analysis for the season with the greatest extents (summer) (Figures 2-9 to 2-12 in Appendix 4) demonstrate the following:

- The duration the ammonia concentration remains above the impact threshold decreases rapidly with increasing distance from the platform.
- Ammonia concentrations exceeding the threshold are limited 99% of the time to within approximately 100m of the discharge point for both the current and proposed flow rates. Continuous durations of 6 hours or more above the threshold are limited to within 50m of the platform.

Other constituents

Dilution plots were developed for the current (33,500 m³/day) and proposed (37,500 m³/day) flow rates (Tables 2-1 to 2-3 in Appendix 4). The results of PFW composition monitoring were assessed to determine if any of the constituents (metals, radionuclides and production chemicals) are above the impact assessment criteria. If constituents were above the impact assessment criteria, the dilution plots were used to predict the area of potential exposure.

Metals

Recent chemical analysis results confirm that the majority of dissolved metal concentrations in the PFW are below the ANZECC 99% species protection levels (ANZECC & ARMICANZ, 2000), with the exception of copper, hexavalent chromium, zinc and mercury.

Based on the highest result recorded for each analyte in the last four years, dilutions of up to 14 times are required to achieve the ANZECC 99% species protection limit. According to the dilution plots (Tables 2-1 to 2-3 in Appendix 4), these concentrations are achieved in the immediate vicinity of the platform during all seasons for both current and proposed flowrates.

Production chemicals

Corrosion inhibitor

Corrosion inhibitor (CRW24060) has an aquatic toxicity level of 0.1 mg/L (LC50 with assessment factor applied). The concentration of corrosion inhibitor in the PFW discharge is 25 mg/L. This requires a dilution of 1:250 to achieve the conservative aquatic toxicity value. Based on the dilution plots for the current and proposed flow rates (Tables 2-1 to 2-3 in Appendix 4), this dilution level is achieved within the mixing zone extent of 256 dilutions.

With frequency and duration considered, concentrations exceeding the threshold are limited to within 600m of the discharge point for over 99% of time and continuous durations over 6 hours to within 400m.

Oxygen scavenger

Oxygen scavenger (OSW24514) has an aquatic toxicity level of 10 mg/L (LC50 with assessment factor applied). As the concentration of oxygen scavenger in the PFW discharge is about 5 mg/L, which is lower than the aquatic toxicity level, the concentration of oxygen scavenger does not contribute to the toxicity of the PFW discharge.

Water clarifier

Water clarifier (RBW24303) has an aquatic toxicity level of 0.17 mg/L (LC50 with assessment factor applied). As the concentration of water clarifier in the PFW discharge is 30 mg/L, this requires a dilution of 1:176 to achieve the conservative aquatic toxicity value. Based on the dilution plots for the current and proposed flow rates (Tables 2-1 to 2-3 in Appendix 4), this dilution level is achieved within the mixing zone extent of 256 dilutions. With frequency and duration considered the potential impact extent is limited to within 300m for 99% of the time and for more than 6 hours continuous duration.

Scale inhibitor

Scale inhibitor (SCW24069) has an aquatic toxicity level of 50 mg/l (LC50 with assessment factor applied). As the concentration of scale inhibitor in the PFW discharge is about 5 mg/L (below the aquatic toxicity level), the discharge of scale inhibitor with the PFW does not contribute to the environmental impact of PFW discharge.

Forward demulsifier

Forward demulsifier (DMO86539) has a static acute aquatic toxicity level of 3 mg/L (LC50 with assessment factor applied). The concentration of forward demulsifier in the discharge is 10 mg/L. As concentration in the PFW discharge is below the aquatic toxicity level, the discharge of forward demulsifier with the PFW does not contribute to the environmental impact of PFW discharge.

Reverse demulsifier

Reverse demulsifier (RBW24362) has an aquatic toxicity level of 100 mg/l (LC50 with assessment factor applied). As the concentration of the reverse demulsifier in the PFW discharge is 12 mg/L, which is significantly lower than 1,000 mg/L, the concentration of reverse demulsifier does not contribute to PFW toxicity.

Temperature

A near-field discharge model was previously used to assess the rate of temperature and dilution of the PFW for the 26,100 m³/d and 33,500 m³/d flow rates.

The modelling results predicted that due to the turbulent mixing caused by the initial plunge and buoyant rise, the temperature of the PFW would return to within 3°C above background within 50m from the platform for all seasons and current speeds. This extent is considered relevant for the proposed flow rate of 37,500 m³/d given that the increase in plume temperature for the

33,500 m³/d flow rate compared to 26,100 m³/d was minor (only up to 0.1°C), and the proposed flow rate will have increased turbulent mixing occur on discharge.

As a minimal increase in temperature is predicted and the extent is localised, impacts to key sensitivities are unlikely.

Summary of potential exposure

The potential area of impact for the proposed flow rate of 37,500 m³/day was determined for each of the PFW constituents using modelling results or dilution plots.

The maximum distance for the whole effluent to achieve ANZECC/ARMCANZ (2000) at PC99 species protection was 3.68km for the proposed scenario and a radius of this extent around the discharge point is defined as the mixing zone boundary of the facility.

Frequency and duration analysis of the PFW stream showed that the threshold is exceeded up to within 600m for 99% of the time and at less than 6 hours continuous duration so it is considered highly unlikely that any potential impacts would extend past this distance. Potential impacts are considered short term and localised.

Hydrocarbon and ammonia were identified as having potential impacts limited to within this mixing zone extent. With frequency and duration considered, the extent was also within 600m for 99% of the time and for periods over 6 hours duration.

OIW concentrations for both oil phases at the Acceptable limit are well within the whole effluent derived mixing zone extent and the concentrations at the Unacceptable limit align with the outer edge of the mixing zone (dissolved oil) and a slight exceedance of 50m (dispersed oil). PFW is managed to keep OIW concentrations within the Acceptable Limit and any exceedances of the Unacceptable limit are considered breaches of a performance outcome and recordable incidents (refer to Section 6.7.6.2).

The remaining constituents all meet their impact assessment criteria within this mixing zone extent.

As new toxicity sampling is undertaken, the resultant mixing zone will be assessed against the Wandoo Facility EP defined mixing zone. If the mixing zone has increased based on modelling outputs, the adaptive management framework will be initiated (Table 6-44).

6.7.4 Field monitoring of PFW

6.7.4.1 Field monitoring and model validation survey (2015)

An environmental monitoring program was undertaken in November 2015 to characterise marine water quality in the vicinity of the WNB Platform, water quality and sediment quality samples were taken as part of the program and to provide a robust dataset for a comparison against dispersion model predictions (Aurecon, 2016).

Water sampling

To characterise the marine water quality in the vicinity of the Wandoo facilities, three types of water quality data were collected from surface water samples, PFW characterisation samples, and water column physico-chemical profiles.

In addition to the water samples collected by the survey team, samples of PFW and ballast water were collected by VOGA production personnel on the Wandoo Platform at the end-of-pipe location prior to PFW discharge and at the end-of-pipe location prior to ballast water discharge. These samples were taken as close as possible to the time PFW water sampling by the field team commenced and concluded.

Surface water sampling

Water samples were taken along two 1km long transects following the modelled direction of the dispersed discharges (approximately in a south-east to north-west alignment). Twenty-one sites were sampled at various depths in total with one site approximately 60m from the discharge point and the remaining sites 20m to 60m apart. Three control sites outside the area of potential exposure were sampled.

TPHS, BTEX and PAHs were below all available ANZECC water quality guidelines 95% species protection levels (ANZECC & ARMCANZ, 2000). Cadmium, chromium, cobalt, copper, lead, mercury and nickel were below the ANZECC water quality guidelines 99% species protection levels (ANZECC & ARMCANZ, 2000) at all sites. Zinc was below the 95% species protection level at all sites. The metal concentrations at all sampling sites were low and did not decrease with increasing distance from the platform with the exception of iron and barium, both were elevated at the discharge site but below 0.01mg/L at all other sites.

As part of this program a total ammonia sample was taken 60m from the discharge point and then at approximately 100m intervals to 400m from the discharge in north-west and south-east transects. At each 100m interval samples were taken at the surface and 1m below the surface. All of the samples were below the ANZECC water quality guidelines 95% species protection level of 0.91mg/L (ANZECC & ARMCANZ, 2000). The total ammonia values were higher at the surface than 1m below the surface and decreased significantly with increasing distance from the platform.

Produced formation water characterisation

As part of the PFW characterisation a drogue was deployed from the survey vessel as close as possible to the platform to:

- Identify the prevailing currents;
- Determine the direction along the transects the samples should be taken; and
- Allow comparisons with predicted trajectories.

Thirty eight PFW characterisation sites were sampled surrounding the platform:

- Transect 1 – 11 sites from the point of PFW discharge to approximately 1,000m from the platform on the flood tide (south-west current direction).
- Transect 2 – 11 sites from the point of PFW discharge to approximately 1,000m from the platform on the ebb tide (north and north-west current direction).
- PFW breadth delineation – along each of Transects 1 and 2, samples were taken across the breadth of the PFW at a distance of 400m from the discharge point (four additional sites sampled at the 400m mark on Transect 1 and five on Transect 2).
- PFW characterisation around discharge – six sites around the point of PFW discharge.

- Sites positioned along Transects 1 and 2 were 60–170m apart. Variation in distance between sites was due to vessel drift while a sample was being taken and the changing direction of the PFW. Sites across the breadth of the PFW were also sampled.

Samples were taken from the surface, 1m depth, and 4m depth. Sites were also sampled at 8m depth surrounding the platform up to a distance of 130m.

Hydrocarbons (TPHs, TPHs, Monocyclic aromatic hydrocarbons including BTEX, and PAHs) in water samples collected at all sites and at all water depths were below the laboratory LORs at all sites and below all available ANZECC & ARM CANZ (2000) 95% species protection guidelines. Barium was the only constituent within the PFW above the LORs in field sampling. As such, barium was used to determine the vertical and horizontal extents and dilution of the PFW trajectory.

Physico-chemical profiles

Vertical water column profiles of temperature, salinity, electrical conductivity, turbidity, dissolved oxygen and pH were obtained over a four day period at 24 surface water quality sites.

Results for a subset of ten sites were analysed in the Environmental Monitoring Report (Aurecon, 2016). Profiles at ten sites showed an overall temperature variation of 2.92°C across all water depths. Temperature was found to decrease with increasing depth at all sites. Overall no elevated temperatures were found at the PFW characterisation sites when compared to the three control sites.

Sediment sampling

Sediment samples were taken along three 900m long transects following the modelled direction of the dispersed discharges (approximately in a south-east to north-west/north-east) alignment. Twenty-two sites were sampled in total with one site approximately 140m from the discharge and the remaining sites 30m to 460m apart. Two control sites outside the area of potential exposure were measured.

TPHs, TRHS and BTEX concentrations were below LORs in all samples from all sites. PAHs were below LORs in all but three samples from two sites. For these results, the concentrations of the PAH species were normalised to 1% total organic carbon (TOC). At both sites the normalised concentrations were below the Sediment Quality Guideline (SQG)-Low of 10mg/kg (Simpson et al. 2013). These results are consistent with the baseline survey (BBG, 1996) and post commissioning surveys (SKM, 1998).

Metal and metalloid concentrations were below ANZECC Sediment Quality Guidelines ISQG-Low trigger values where available (ANZECC & ARM CANZ, 2000). No trigger values were available for aluminium, barium, cobalt, iron, manganese, selenium or vanadium, but concentrations 140m from the discharge sites were similar to concentrations at the control sites.

There are currently no ANZECC Guidelines for nutrient concentrations in sediment samples, however concentration of nitrogen (total Kjeldahl nitrogen and total nitrogen) were generally lower at all sites along all three transects and at the discharge site compared to the control sites.

6.7.4.2 Modelling verification assessment

Retrospective modelling was undertaken to determine if the field modelling results aligned with the PFW model predictions (RPS APASA, 2016).

The scope of the verification assessment was as follows:

- Compare wind and current measurements taken during field sampling with wind and current predictions from model; and
- Conduct PFW dispersion modelling immediately prior (18–20 November 2015) and during (21–22 November 2015) the PFW investigations to establish the model predicted dilution contours and compare the model predictions with the measurements.

The wind speed and current measurements taken during field sampling compared well with PFW modelling predictions.

The drogoue tracks measured during the sampling compared well with the PFW modelling predictions, hence providing confidence in the accuracy of the predicted currents used in the discharge model.

The criteria used to compare the predicted PFW dilution contours with the field measured dilutions was at the time of sample collection was the predicted PFW boundary and the sample site within 200m and the concentrations (or dilutions) within a factor of two. The basis for the specific criteria was adapted from findings from King and McAllister (1998).

On both days of sampling the majority of results were within the criteria. On the first day of the PFW investigations (21 November 2015), nine sampling sites had measurable barium concentrations above the LOR. Based on the comparison criteria the model results and measurements agreed at six of these sites. For the other three sites, the distance was within 260–300m.

There were eight sites out of 19 with measurable barium concentrations above the LOR, on the 22 November 2015. The model results met the criteria at six of these sites. The distance from the boundary of the predicted PFW to the remaining two sampling sites (which did not meet the criteria) were within 300–460m. The positional differences could be contributed to a one to two hour difference between the timing of the predicted tide.

In all instances, the extent of model predicted concentrations corresponded to field measurements.

6.7.4.3 Conclusion

Overall, the field based environmental monitoring provided no evidence of any long term cumulative impact on either sediment or water quality from the discharge of PFW from the Wandoo platform.

The field monitoring results aligned with the PFW dilutions modelling and provided verification of the inputs and basis of the modelling.

6.7.5 Impact of PFW

6.7.5.1 Hydrocarbons

Hydrocarbon was identified as having potential impacts limited to within the full mixing zone extent of 3.68km.

Within this full extent of potential exposure, impacts to key sensitivities are unlikely as:

- with frequency and duration considered, the extent was limited to within 600m for 99% of the time and for periods over 6 hours continuous duration.
- species such as fish, marine mammals and reptiles are highly mobile and have the ability to swim and move in and out of the PFW.

There are no coral, mangroves or seagrass in the potential exposure area. Planktonic organisms are the most vulnerable to effects from the PFW discharge, as they drift freely in the water column and are unable to avoid interaction with the PFW. Exposure of zooplankton to hydrocarbons for extended periods (days to weeks) has resulted in growth inhibition (Vieira and Guilhermino, 2012). As modelling results predict that the maximum continuous duration of exposure immediately at the discharge point will be limited to approximately 12 hours and for 6 hours continuous duration within 600m, the duration of exposure is unlikely to be long enough to result in growth inhibition. Other species such as fish, marine mammals and reptiles are highly mobile and have the ability to swim and move in and out of the PFW. Their movement combined with the dynamic nature of the PFW means exposure is likely to be intermittent and unlikely to result in any impact. As potential area exposure for OIW is within 600m, with frequency and duration of exposure considered, exposure of sensitivities is likely to be intermittent and potential impacts unlikely.

Bioaccumulation is the uptake and retention of bioavailable chemicals from any one or all possible external sources. Of petroleum hydrocarbons present in PFW, PAHs have the highest potential to bioaccumulate. Concentrations of PAHs in the aquatic environment are generally highest in sediment, intermediate in biota and lowest in the water column (CCME, 1992). Aquatic organisms may accumulate PAH from water, sediments and food. Organisms that metabolise PAHs, such as fish and higher invertebrates including arthropods, echinoderms and annelids, accumulate little or no PAH. Bioaccumulation of PAHs is evident in algae and lower invertebrates with some biomagnification to higher trophic levels. Results of recent sediment sampling indicate that PAH concentrations were below LORs and ISQG-Low values (Simpson, 2013) they are also consistent with the results of previous surveys by BBG (1996) and SKM (1998). Results of surface water sampling also indicated that PAHs were below all available ANZECC Water Quality Guidelines 95% species protection levels. As PAH concentrations are low in the waters and sediments surrounding the WPF, bioaccumulation of PAHs in algae and lower invertebrates is highly unlikely.

The impact of the PFW on key sensitivities is detailed in Table 6-43.

6.7.5.2 *Metals*

Recent chemical analyses confirm that the majority of dissolved metal concentrations in the PFW are generally below the ANZECC 99% species protection level (ANZECC & ARMCANZ, 2018), with the exception of copper, hexavalent chromium, zinc and mercury. According to the dilution plots (Tables 2-1 to 2-3, Appendix 4), this concentration is achieved in the immediate vicinity of the platform for the four metals during all seasons.

Metal concentrations are directly related to the characteristics of the reservoir and have remained consistent over time. Regular PFW monitoring will be performed in accordance with Table 6-44 to determine if metals are below ANZECC 99% species protection levels (ANZECC & ARMCANZ, 2018).

Metals such as mercury, selenium and cadmium have the greatest potential for bioaccumulation and secondary poisoning in biota, although bioaccumulation may occur for a range of metals

(ANZECC & ARMCANZ, 2018). The bioaccumulation of metals is a complex process and depends on the concentration and bioavailability of metals and physiology of individual species. It can vary greatly among species in the same environment (Luoma and Rainbow, 2005). Heavy metals in PFW also undergo a series of chemical reactions once they enter seawater and ultimately precipitate out as metal hydroxides or sulphides (E&P Forum, 1994). Metals present as hydroxide or sulphides are generally not available for biological uptake (Luoma and Rainbow, 1977) and unlikely to bioaccumulate in biota. The results of the 2015 sediment sampling confirmed that concentrations of mercury and cadmium were below ANZECC ISQG Low trigger values, hence unlikely to bioaccumulate. These results are also consistent with the results of previous surveys by BBG (1996) and SKM (1998). This confirms that no bioaccumulation of heavy metals has occurred as a result of continuous PFW discharge over a period of 18 years. The concentration of selenium was similar to that at the control sites, which indicates bioaccumulation is unlikely.

Barium, iron and manganese are the metals most often greatly enriched in PFW compared to their concentrations in natural seawater. All other metals tested are present in PFW in chemically reactive dissolved forms at concentrations similar to or only slightly higher than concentrations in seawater, and are unlikely to cause adverse effects in the receiving environment (Neff et al., 2011). The results of the 2015 sediment sampling indicate that barium levels were slightly elevated in comparison to concentrations at the control site. These levels were lower than the previous post commissioning survey (SKM, 1998) and slightly higher than the baseline (BBG, 1996). Although levels of barium were slightly above levels at control sites, barium is not readily accumulated in the soft or hard tissues of marine fauna due to its low solubility (Neff, 2002).

6.7.5.3 Ammonia

In the aqueous environment, ammonia is present in two forms: ionised ammonium (NH₄⁺) and un-ionised ammonia (NH₃), in accordance with the following equilibrium equation (Russo, 1985):

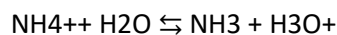

Ammonia is degraded in the marine environment by the following mechanisms: ammonium can be oxidised to nitrite then nitrate by a two-step process by aerobic bacteria (Nitrosomonas and Nitrobacter, primarily) (Wetzel, 2001). Ammonia, nitrite and nitrate are also rapidly assimilated from water by phytoplankton algae and bacteria as sources of nitrogen (Dodds et al., 2002; Smith, 2003; Zehr, 2011). As ammonia is rapidly assimilated in sea water as part of the nitrogen cycle, the likelihood of marine species being exposed to ammonia is reduced.

The results of ammonia modelling indicate that the area of potential exposure is within 500m of the discharge. However, the ammonia modelling results used in the impact assessment are based on physical dilution methods and do not take chemical and microbial degradation and assimilation of ammonia into account. Therefore, the extent of the impact described within this assessment is considered to be conservative to ensure the largest possible extent of the impact is addressed.

Within this area of potential exposure, it is likely that ammonia breaks down quicker than indicated by the modelling, as the modelling does not take the chemical and microbial degradation of ammonia into account.

No coral, mangroves or seagrass are present in the area of potential exposure. Ammonia toxicity to plankton and other marine species is due to un-ionised ammonia rather than ammonium. Exposure to un-ionised ammonia can inhibit the growth of phytoplankton and result in reduced

reproduction of red macroalgae (Admiraal, 1977). As plankton and larvae are constantly transiting the area due to being transported by ocean current, exposure is unlikely to affect growth and reproduction.

In areas of low water currents and high nutrient concentration, ammonia may stimulate microalgae and phytoplankton growth, leading to eutrophication. This is highly unlikely in the open water environment at Wandoo, and the results of surface water and sediment monitoring confirm that nutrient levels are low.

Un-ionised ammonia can easily cross through fish gills, resulting in cellular damage (Levit, 2010). The influence of the toxicity of ammonia to fish is impacted by the frequency and duration of exposure (Milne, 2000). As the ammonia concentration is likely to be above 0.50 mg/L for low frequencies and durations within the area of exposure, and fish tend to dwell in deeper waters and are also highly mobile with the ability to swim in and out of the PFW, exposure is likely to be intermittent and unlikely to result in any impacts.

Impacts to marine mammals and reptiles as a result of exposure to ammonia are unlikely, as the toxicity of nitrate also decreases with increasing species size and water salinity (Tsai and Chen, 2002). Marine mammals can also tolerate ammonia levels that would be toxic for fish (CRC, 1990).

As the predicted potential area of exposure is within 50 m, with duration and frequency considered, exposure of key sensitivities is likely to be intermittent and unlikely to result in any impacts. The impacts of the ammonia on key sensitivities is outlined in Table 6-43.

Bioaccumulation of ammonia in biota is considered highly unlikely in the marine environment, as it is highly soluble and does not accumulate in lipid rich tissues in the same manner as organic chemicals (Environment Agency, 2007). The results of water quality and sediment sampling confirm that bioaccumulation of ammonia in the marine environment is unlikely.

The water quality monitoring in 2015 detected concentrations of ammonia below ANZECC 95% species protection levels (ANZECC & ARMCANZ, 2000) in samples in relatively calm conditions, which was not conducive to dilution (Aurecon 2016). Results of 2015 sediment sampling confirmed that nutrient levels at sampling points within the area of potential exposure were lower than at control sites.

6.7.5.4 Radionuclides

PW may include low levels of naturally occurring radionuclides (NORMS) in particular, uranium 238 and thorium 232 decay chains and the longer-lived radionuclides lead 210, polonium 210, radium 226 (Ra-226) and radium 228 (Ra-228) (Coleman and West 2000). These radionuclides can occur in produced water either in solution or as fine mineral suspended solids (OSPAR Commission 2009).

The most significant radioactive element in PFW is radium-226, which is an alpha emitter with a half-life of 1,620 years. Levels of radium-226 and radium-228 within the Wandoo PFW (refer Table 1.6 in Appendix 4) are within typical levels for PFW recorded at other oil and gas platforms. Typical total radium concentrations in PFW range from 0 to 190 Bq/L respectively (Neff, 2002). A study of 41 oil and gas platforms in Norway found radium-226 concentrations in PFW ranged from 0.5 to 16 Bq/L and radium-228 concentrations ranged from 0.5 to 21 Bq/L.

Concentrations of Ra-226 and Ra-228 were at the lower end of the range of measured values in PWs from different global locations and several orders of magnitude higher than background

seawater concentrations (Jacobs 2019c, Neff et al., 2011). Currently there are no ANZG (2018) guidelines or international guidance for concentrations of radionuclides in marine water, however, concentrations were similar to the drinking water guidelines (WHO, 2017).

Valeur and Petersen (2013) assessed the ecological hazard related NORMs in PW discharged to the marine environment. They concluded that NORMs have a strong affinity for particulate matter and discharged NORMs would be adsorbed onto fine grained sediments and particulate matter relatively soon after introduction to the marine environment. In high energy environments, NORMs associated particles would settle and resuspend numerous times until they eventually settle in low energy environments in deep parts of the sea that serve as accumulation areas for fine grained sediments. Over time these particles would be buried beneath the benthic mixing layer of the seabed where they will become isolated from the biosphere, and are unlikely to exceed background levels.

The insolubility of radium based radionuclides ensures levels in the water column remain very low and rapidly return to background levels within close proximity of the discharge. Published literature indicates that radium-226 levels will not deviate significantly from the background values in receiving areas at distances no greater than 250 m surrounding offshore platforms (Vegueria et al. 2002). As the concentration of radionuclide discharged from the PFW is relatively low, no impacts are anticipated.

6.7.5.5 *Production chemicals*

The dilution plots indicate that all the production chemicals reach their conservative aquatic toxicity values within the whole effluent derived mixing zone for all seasons.

Exposure of key sensitivities is likely to be intermittent and unlikely to result in any impacts. Plankton and larvae are also constantly transiting the area of exposure due to ocean currents; hence, exposure is likely to be short term and localised.

6.7.5.6 *Temperature*

Near-field temperature modelling results for the current flow rate indicates that the temperature of the PFW would return to within 3°C above background levels within 50 m from the platform for all scenarios and seasons. As a minimal increase in temperature is predicted and the area is localised, impacts to key sensitivities are unlikely.

6.7.5.7 *Net environmental impact assessment*

Current Scenario

The results of PFW modelling and environmental monitoring indicate that the current discharge of PFW at Wandoo is having a minimal environmental impact. The modelling results indicate that the area of exposure for the current maximum flow rate (33,500 m³) is within approximately 3.65 km of the platform for all components, with a mixing zone boundary defined as 3.65 km.

Frequency and duration analysis of the PFW stream showed that the threshold is exceeded for 99% of the time and above 6 hours continuous duration within 600m so it is considered highly unlikely that any potential impacts would extend past this distance. Potential impacts are considered short term and localised.

The results of modelling are based on conservative impact assessment criteria and modelling methodology/inputs that have been validated by field monitoring (Section 3.3.3).

The 2015 field monitoring showed that hydrocarbons, ammonia and metal concentrations in surface waters were below the ANZECC 95% species protection levels (ANZECC & ARMCANZ, 2000). Levels of PFW constituents in surface water and in sediment are also low, demonstrating no evidence of any long term cumulative effects.

Results of routine PFW monitoring confirm that all the components of PFW with the exception of ammonia and some metals are below impact assessment criteria. As ammonia levels are above assessment criteria and hydrocarbons are a key component of PFW, more detailed assessment of the frequency and duration of exposure of potential hydrocarbon and ammonia impacts was also undertaken. Based on the modelling results the potential frequency and duration of exposure within the PFW is low for ammonia and hydrocarbons, and within the mixing zone.

The hydrocarbons contained within the PFW have the potential to impact marine species through ingestion of dissolved components and/or through physical effects resulting from contact of hydrocarbons present at the sea surface whereas the ammonia content of the PFW is rapidly assimilated in the marine environment as part of the nitrogen cycle (Dodds et al., 2002; Smith, 2003). On this basis, improvements to the quality of discharge should focus on reducing the OIW content of the PFW as a priority.

A detailed assessment of the potential impacts of hydrocarbons and ammonia on key sensitivities is described in Table 6-43.

Exposure of planktonic organisms to hydrocarbons and un-ionised ammonia has the potential to inhibit growth (Admiraal 1977; Vieira and Guilhermino, 2012). As the durations and frequency of exposure within the mixing zone extent are low and plankton are constantly transiting the area due to ocean currents, exposure is unlikely to affect growth and reproduction.

Hydrocarbons have the potential to impact marine mammals and reptiles through the inhalation of vapours as they surface to breathe. Hydrocarbons can impact marine fish through the ingestion of entrained droplets; un-ionised ammonia can easily cross through fish gills causing cellular damage (Levit, 2010).

No Commonwealth or State Marine Protected Areas intersect the mixing zone extent. Five Biologically Important Areas intersect the mixing zone extent. Although interaction with the area of exposure has the potential to cause impacts to fish, marine mammals and reptiles, the duration of exposure within the PFW is low and these species are highly mobile and have the ability to swim and move in and out of the area of exposure. The area of the mixing zone is very minimal compared to the BIA areas (less than 0.01%). Therefore, exposure periods will be intermittent and highly unlikely to result in any potential impacts to key sensitivities exceeding a short term and localised basis.

Proposed Scenario

The proposed scenario will result in a minor increase in the potential area of impact when compared to the current scenario. The modelling results indicate that the area of exposure is within 3.68km of the platform for all constituents, an increase of less than 1% (30m) from the current scenario.

Frequency and duration analysis of the PFW stream showed that the threshold is exceeded up to within 600m for 99% of the time and at less than 6 hours continuous duration so it is considered highly unlikely that any potential impacts would extend past this distance.

Although the maximum distance from the platform for whole effluent toxicity to reduce below impact thresholds may increase, the area of potential impact from ammonia and OIW is likely to remain very similar (dissolved oil and ammonia) or slightly reduced (dispersed/entrained oil).

Modelling predicts that the potential exposure for metals and production chemicals for the proposed scenario will be similar to the current scenario.

The hydrocarbon content of the PFW has the potential to impact on a number of key sensitivities such as plankton, marine mammals and reptiles, and fish as outlined above and in Table 6-43.

In comparison to the current scenario the proposed scenario presents a minor increase in the overall impact of PFW. As hydrocarbons in PFW are more persistent and likely to impact on marine sensitivities than other components, the extent of potential hydrocarbon impacts remaining similar or slightly reducing will overall ensure potential PFW impact is not significantly increased. Therefore, increasing the PFW flow rate is expected to result in a negligible increase in the overall impact of PFW.



Table 6-43: Key ecological sensitivities and potential effects from PFW exposure

Sensitive receptor	Potential interaction with PFW	Potential Impact within the PFW Mixing Zone
Key ecological features National/ World Heritage Areas Commonwealth/State Marine Protected Areas	None in the vicinity of the current or proposed area of potential exposure.	None in the vicinity of the current or proposed area of potential exposure hence no potential impact. The closest AMPs to the Mixing Zone are the Montebello Marine Park (approximately 35 km west) and Dampier Marine Park (approximately 38 km southeast). The Mixing Zone is 40km from the nearest KEF (Glomar Shoals). Given the distance from the discharge source, no impacts to the Marine Park or KEF are anticipated. Routine monitoring detects changes at the approved mixing zone boundary.
Coral reef communities, seagrass, mangroves, intertidal mud and sand flats, rock shorelines intertidal platforms	Not present in the vicinity of the current or proposed area of potential impact.	There are no potential impacts, as these marine habitats are not present in the area of potential exposure. The nearest area of significant corals reef to the Mixing Zone are the Glomar Shoals (approximately 40 km northeast) and Dampier Archipelago (approximately 40 km southeast).
Macroalgae	Macroalgae is not known to occur in the Mixing Zone although may be present on the platform as marine growth in the upper layer of the water column.	Complete or partial mortality of kelps is possible at exposure concentrations (>10mg/L) of TPH as chemically dispersed oil (Ross, 2002). Exposure of macroalgae to these concentrations is unlikely as PFW monitoring results indicate that TPH concentrations are generally less than 10mg/L. Ammonium ions in aqueous solution can stimulate the growth of primary producers such macroalgae, potentially resulting in nuisance algal blooms which can lead to eutrophication of aquatic ecosystems (Camargo and Alonso, 2007). High nutrient concentrations and coupled with reduced current flow are required for eutrophication to occur. This is unlikely in this case as the open water marine environment at Wandoo is subject to continuous currents. A recent review of the biochemistry of the NWS found also found that ambient levels of nitrate in surface waters are low and levels of phytoplankton are nitrogen limited (Heyward, 2006). Frequency and duration analysis of the PFW stream showed that the threshold is exceeded up to within 600m for 99% of the time and at less than 6 hours continuous duration so it is considered highly unlikely that any impacts would extend past this distance. Potential impacts are localised and short term.
Marine mammals	Cetaceans which are listed as threatened or migratory under the EPBC Act may potentially transit through the Mixing Zone. Foraging BIA for the Humpback, and a distribution BIA for the pygmy blue whale	Marine mammals in the vicinity of the platform may come in contact with the area of potential exposure as they surface to breathe. There is potential for volatile hydrocarbons to be inhaled by cetaceans if they were to surface within the area of exposure. The level at which impacts may occur as a result of exposure to hydrocarbons on the sea surface has been conservatively defined as 1.0g/m ² (APASA, 2013b) as applied to interaction of surface oil with seabirds. The threshold for marine mammals is likely to be much higher and unlikely to be achieved during normal operations as oil is continually entrained into the water column. To achieve the 1.0g/m ² threshold requires all the oil in the 0-1m depth to be at the surface layer. Whales and dolphins may also experience irritation to their eyes and tactile hair follicles upon contact with surface oil, but lasting effects on skin tissue may be less likely (Geraci, 1990). These effects were documented for gasoline and crude oil spills, which have a considerably higher concentration of OIW than PFW. The toxicity of nitrate decreases with increasing species size and water salinity (Tsai and Chen, 2002), hence impacts to marine mammals as a result of ammonia exposure are unlikely. Marine mammals can also tolerate ammonia levels that would be toxic for fish. The mixing zone is within a foraging BIA for the Humpback, and a distribution BIA for the pygmy blue whale. Both cetaceans are expected to be in the mixing zone on a transitory basis and would only interact with the PFW stream when come to the surface to breath. Frequency and duration analysis of the PFW stream showed that the threshold is exceeded up to within 600m for 99% of the time and at less than 6 hours continuous duration so it is considered highly unlikely that any impacts would extend past this distance. The area of potential impact is minimal in comparison to the area of the BIAs (less than 0.01%). Potential impacts are localised and short term. Dolphins, may intercept the area of high ammonia concentration as they return to the surface to breath. Dugongs are mainly found in shallow waters where seagrass beds flourish hence it is unlikely that they will be found in the vicinity of the Mixing Zone.



Sensitive receptor	Potential interaction with PFW	Potential Impact within the PFW Mixing Zone
<p>Marine reptiles</p>	<p>Sea snake and turtle species listed as protected under the EPBC Act may potentially occur within the Mixing Zone however unlikely to occur in large numbers. Flatback turtle internesting BIA</p>	<p>Sea turtles may be exposed to the PFW as they surface to breathe (Ober, 2010). Sea snakes may also interact with the PFW during surface swimming. Harmful effects may occur through ingestion of oil, inhalation of toxic vapours (e.g. close to the spill source) or irritation to the head, neck and flippers due to oil contact with the skin.</p> <p>The mixing zone is within a large nesting BIA for flatback turtles; and although there may be transient individuals most females internest close to their nesting beaches, typically in shallow (0–10 m) nearshore waters of their nesting beach (Chevron 2008) – unlike the depth of the Mixing Zone at the Wandoo Facility at 50 m depth, and the nearest significant nesting beaches are > 35km away at Dampier Archipelago.</p> <p>The bioaccumulation/ biomagnification risk to marine turtles or the impact pathway is through the food chain. However as described above, the BIA area for flatbacks overlapping the Mixing Zone is for internesting. The study by Sperling et al. (2010) concluded that flatback turtles do not feed during the internesting period which greatly reduces the risk of bioaccumulation/ biomagnification. However, if individuals were likely to use this area as foraging grounds, outside of nesting season it would represent an insignificant percentage of all available nesting grounds and not significantly impact individuals or population.</p> <p>'Management of oil spills and operational discharges' is identified as an action in the Turtle Recovery Plan (DoEE 2017). However, the total size of the BIA for Pilbara flatbacks is 35,758,776 km². The areas that may potentially be affected by produced water discharges (water quality of 3.5km²) represents less than 0.01% of the total area.</p> <p>Frequency and duration analysis of the PFW stream showed that the threshold is exceeded up to within 600m for 99% of the time and at less than 6 hours continuous duration so it is considered highly unlikely that any impacts would extend past this distance.</p> <p>There is no specific threshold for turtles, although there is reference to a study where turtles were exposed to a 0.05cm surface layer of oil (NOAA 2010) that resulted in significant effects. The 0.05cm layer is equivalent to 500µm which is 50 times higher than the 1.0g/m² (or 10µm) threshold used for seabirds. No impact is anticipated as the threshold concentration is much higher than the concentration likely at the surface.</p> <p>It is possible for marine reptiles such as turtles to be exposed to ammonia on an intermittent basis when they surface to breathe (Ober, 2010).</p> <p>Impacts to marine reptiles as a result of ammonia exposure are unlikely as their size allows them to tolerate high ammonia concentrations.</p> <p>Therefore, the likelihood of marine reptiles being impacted by ammonia is the same for the current and proposed flow rate.</p>
<p>Fish, sharks and rays</p>	<p>Sharks and ray species listed as Threatened or Migratory under the EPBC Act that may potentially occur in the Mixing Zone, however are unlikely to occur in large numbers. Various species of fish are present in the Mixing Zone Foraging BIA for whale sharks.</p>	<p>The main exposure pathway of sharks and rays to hydrocarbons is through the ingestion of entrained droplets.</p> <p>The mixing zone is within the foraging BIA for whale sharks; however, it is known that the whale sharks are more common migrating along the 200 m depth contour, which is further offshore to the Wandoo facility. Given the area of impact and that whale sharks are transiting the area and not within the plume for any more than very short term periods, no impacts are expected.</p> <p>Frequency and duration analysis of the PFW stream showed that the threshold is exceeded up to within 600m for 99% of the time and at less than 6 hours continuous duration so it is considered highly unlikely that any impacts would extend past this distance. The area of potential impact is minor in comparison to the area of the BIA. Potential impacts are localised and short term.</p> <p>Whale sharks spend the majority of their time in deeper waters, and would avoid the surface produced water plume, however it may have a small indirect effect on plankton which is a food source for whale sharks (Meekan 2008). The predicted small scale of the area of impact however suggests that exposure impacts (sublethal or lethal) from produced water is not likely to significantly impact whale shark food sources. The areas that may potentially be affected by produced water discharges (water quality of 3.5km²) represents less than 0.01% of the total BIA area.</p> <p>The Conservation advice for the whale shark identifies habitat disruption from the resource sector as a minor threat to the species (SPRAT Whale shark, DEE 2017as). However as described above the release of produced water is not likely to have any impact on the species or habitat used by the species.</p> <p>Fish also dwell in the water column hence exposure to the PFW is unlikely. Potential indirect exposure may occur through feeding on biofouling organism settled on the platform structure. Frequency and duration analysis of the PFW stream showed that the threshold is exceeded up to within 600m for 99% of the time and at less than 6 hours continuous duration so it is considered highly unlikely that any impacts would extend past this distance and unlikely for potential impacts be greater than minor.</p> <p>As the PFW remains in the surface layers (top 3m) and considering that these species dwell in deeper water, potential impacts are unlikely.</p> <p>Un-ionised ammonia can cross easily into fish gills, there it converts to the un-ionised form which can cause cellular damage (Levit, 2010).</p> <p>Very high concentrations of ammonia may cause acute toxicity to fishes, resulting in loss of equilibrium, hyper excitability, increased breathing rate, cardiac output and oxygen uptake and in extreme cases coma and death. Chronic effects of ammonia toxicity include a reduction in hatchling success, reduction in growth rate and morphological development and pathological changes in gill liver and kidney tissue (Levit, 2010).</p> <p>The area of exposure for ammonia mainly exists in the top 3m for the current and proposed scenario, as fish and sharks mainly dwell in the lower sections of the water column and are highly mobile the likelihood of exposure is low.</p>



Sensitive receptor	Potential interaction with PFW	Potential Impact within the PFW Mixing Zone
Seabirds	Threatened and Migratory species of birds may transit through the Mixing Zone Breeding BIA for the Wedge-tailed Shearwater	The mixing zone is within a large breeding BIA for the wedge-tailed shearwater; these BIAs are based on buffer areas surrounding the offshore islands (e.g. within Dampier Archipelago) that are used for nesting by this species. When foraging at sea the birds are often alone or in small groups and are unlikely to be impacted by change in water quality associated with the produced water discharge plume in the upper water column. Additionally, like with the turtles BIA, the proportion of foraging area likely to be impacted by produced water discharges (3.5km ²) is minimal. Seabirds may interact with the PFW as they surface to breathe. Impacts to seabirds are highly unlikely as the concentration of OIW in the PFW is very low. As the 1g/m ² threshold is equivalent to a 10µm surface layer and the surface oil is continuously entrained through the water column, impacts to seabirds are considered unlikely. Scholten et al., 1996 indicates that a layer of 25µm thick would be harmful to birds that contact the slick. Estimates for the minimal thickness of oil that will result in harm to seabirds through ingestion from preening of contaminated feathers, or the loss of thermal protection of their feathers, has been estimated at 10µm (French, 2009) to 25µm (Koops et al., 2004). Seabirds may come in contact with ammonia as they surface to breathe. However, they are unlikely to be in contact with ammonia for periods long enough to cause impacts. Frequency and duration analysis of the PFW stream showed that the threshold is exceeded up to within 600m for 99% of the time and at less than 6 hours continuous duration so it is considered highly unlikely that any impacts would extend past this distance. The area of potential impact is minor in comparison to the area of the BIA. Potential impacts are localised and short term.
Plankton	Ubiquitous in the Mixing Zone	Hydrocarbons are toxic to both phytoplankton and zooplankton. Plankton are widely distributed and dispersed throughout the upper layers of the water column (Payne, 1992) hence potentially affected by PFW discharge. Exposures to oil concentrations between 50–300µg/L for extended periods (days to weeks) have demonstrated to have sub-lethal impacts on laboratory cultures of zooplankton (NRC, 1985). Although concentrations are below the NOEC threshold, they represent laboratory based results which are overly conservative compared to field based exposures. Extended exposure to the concentrations mentioned are also unlikely as the plankton are in constant motion both horizontally (in response to currents) and vertically (in response to diel migration) hence the likelihood of extended exposure to hydrocarbons beyond 12 continuous hours is considered to be very low. Plankton cultures exposed to concentrations of PAH 0.048–0.831mg/L at 25°C over 96 hours showed a notable inhibition in growth (Vieira and Guilhermino, 2012). Exposure to un-ionised ammonia can inhibit growth phytoplankton and result in reduced reproduction of red macroalgae (Admiraal, 1977). As the predicted potential area of exposure for the high flow rate is relatively small (300m) and plankton and larvae are constantly transiting the area due to ocean current transportation exposure is unlikely to affect growth and reproduction. Ammonium ions in aqueous solution can stimulate the growth of phytoplankton, potentially resulting in algal blooms which can lead to eutrophication of aquatic ecosystems (Camargo and Alonso, 2007). High nutrient concentrations and coupled with reduced current flow are required for eutrophication to occur. This is unlikely in this case as the open water marine environment at Wandoo is subject to continuous currents. A recent review of the biochemistry of the NWS found also found that ambient levels of nitrate in surface waters are low and levels of phytoplankton are nitrogen limited (Heyward, 2006). The study also found that very little nitrate exists in surface waters. Frequency and duration analysis of the PFW stream showed that the threshold is exceeded up to within 600m for 99% of the time and at less than 6 hours continuous duration so it is considered highly unlikely that any impacts would extend past this distance. Potential impacts are localised and short term.
Fisheries and aquaculture	Some managed fisheries overlap the current and proposed area of potential exposure; however, no vessels are permitted within the 500m PSZ and the extent of potential impacts are highly unlikely outside 600m.	The mixing zone extends up to a maximum 3.68km however based on fishing effort, none of the Commonwealth managed fisheries are expected to be active within the mixing zone in the close vicinity of the Mixing Zone. Minimal fishing activity from the State managed PLF and PFTIMF may occur within close proximity to the Mixing zone. Frequency and duration analysis of the PFW stream showed that the threshold is exceeded up to within 600m for 99% of the time and at less than 6 hours continuous duration so it is considered highly unlikely that any impacts would extend past this distance. The area of the mixing zone is minimal (3.5km ²) compared to fishing areas. Potential impacts are localised and short term. Fishing in the vicinity of the area of potential impact is unlikely as most fisheries operate in deep water seaward of the Mixing Zone and are not permitted within the 500m PSZ. Fishing vessels are not commonly seen surrounding the Facility.
Shipping	Shipping lanes do not overlap the proposed area of potential impact.	No impact from PFW as a result of current or proposed scenario flow rates. The Mixing Zone is approximately 25 km from the northbound shipping fairway from Dampier.
Other users	There are no tourism activities in the vicinity of the current or proposed area of potential exposure.	As there are no tourism activities in the vicinity of the PFW there is no potential impact.

6.7.6 PFW and ballast water management

6.7.6.1 Overview

The objective of the PFW and ballast water adaptive management framework (Table 6-44) is to monitor and manage the potential impacts of PFW on the marine environment within the 510m defined mixing zone at a flow rate of 33,500m³/day. This framework outlines the routine PFW monitoring and actions undertaken if the monitoring results exceed the defined trigger values.

The following sections provide a summary of the strategies to manage PFW and ballast water, and any deviations, as described within the Produced Water Adaptive Management Strategy [WNB-7000-RP-0010]. The management strategy addresses:

- Managing OIWs within limits to minimise exceedance of acceptable levels
- OIW and PFW measurement and monitoring;
- Alarm philosophy;
- Process excursions and upsets; and
- Equipment calibration.

6.7.6.2 Acceptable and Unacceptable Limits

Performance of water treatment and OIW exceedences of the acceptable and unacceptable limits (based on the flow regime Table 6-38) are monitored and corrective actions implemented in accordance with the Platform Operations Manual [VOG-7000-MN-0001]. The aim of the strategy is to minimise the likelihood of limits being exceeded by taking a phased approach with escalating corrective actions as performance of water treatment system degrades (OIW increases). The strategy includes:

- monitoring and recording exceedences over short durations throughout the day (see Sections 6.7.6.4 and 6.7.6.6);
- a framework for operators to take action to adjust and improve performance when OIW values are exceeding acceptable values to minimise likelihood of the limit being exceeded over a 24-hr period (see section 6.7.6.5);
- developing a plan to address and improve OIW performance when 24-hr acceptable limit is exceeded; and
- Reporting criteria for OIW events so non-conformances are investigated .
- Exceedences of the Unacceptable limit are considered breaches of a performance outcome and recordable incidents.

6.7.6.3 Inline OIW analysers and manual analysis

The primary method of quantifying OIW in PFW and ballast water is based on inline OIW analysers. The analysers provide real-time OIW values to the WNB control room. Actuals are logged and recorded within servers located on WNB (called the MCS). This history can be recalled for OIW performance review.

The objective of the two daily manual laboratory samples are to act as a verification of the inline OIW analyser performance. The optimal cleaning requirement for the inline OIW analysers to maintain accuracy is two times daily.

The 24-hour MCS OIW average, average daily manual laboratory samples and OIW targets are reported on the Wandoo daily report for PFW and ballast water.

6.7.6.4 Alarm philosophy for inline OIW analysers

Early detection of OIW excursions allow earlier intervention and reaction to ensure overboard discharge of PFW remains within specification. Alarm points are set via programmed values based on the accepted 24-hour maximum OIW limits.

Continuous monitoring of the produced and ballast water flows are maintained by the inline OIW analysers. These instruments provide continuous reading back to the MCS in the Central Control Room (CCR). The MCS records and trends the OIW readings from the inline OIW analysers and is configured to alarm if either water stream goes out of specification.

The alarms are set via programmed values based on the Acceptable and Unacceptable daily OIW averages for the relevant Flow Regime. The MCS calculates and records the following:

- instantaneous OIW content
- 20 minute average OIW content
- rolling 24 hour (daily) average OIW content

The above readings are displayed and trended on the MCS to aid the operation of the PWTS and are alarmed to alert the CCR Operator. Based on these alarms, the CCR Operator is to initiate corrective actions to prevent the 24 hour (daily) average exceeding the Unacceptable Limit, should process upsets or disruptions to the ancillary systems (ie. chemical injection or sediment ingress) cause excursions or deviations of the OIW content from the normal operating range.

6.7.6.5 Process upsets

To continually manage OIW to ALARP an internal OIW excursion event 'Flag' system has been implemented. The 'Flag' is a communication tool used to record the short duration process excursions based on a pre-determined time weighted OIW average. If a 'Flag' occurs, details are noted within a log sheet by WNB control room personnel and potential influencing factors are noted. Flagged excursions are then reviewed by WNB operators for trends to assist in identifying contributing factors and minimising future events.

If high OIW levels persist over time, WNB operators respond in accordance with the Platform Operations Manual [VOG-7000-MN-0001] High Oil in Water Optimisation Procedure [WNB-012-503]. WNB has limited capacity within Shaft 4 to handle diverted out of specification PFW therefore a sustained OIW excursion may lead to production curtailment or shutdown so the daily Unacceptable OIW limit is not exceeded.

6.7.6.6 Monitoring deviations

Deviation of the instantaneous inline OIW analyser reading from the twice daily manual laboratory results will be managed in accordance with Table 6-44. If cleaning and calibration of

the inline OIW analyser does not reduce the amount of deviation, regular (four hourly) manual samples will be undertaken until the deviation is resolved.

A deviation between the manual laboratory results and NATA laboratory analysis will be managed in accordance with Table 6-44. Historically the levels of TRH and PAH have been compared against the OIW manual laboratory and inline analyser at the time of sampling. The total NEPM TRH are the most closely aligned with the offshore OIW monitoring methodologies. Only trace amounts of PAH were detected within the PFW and ballast water samples.

For the past three years, monthly NATA laboratory total TRH samples have been predominantly below those estimated by the offshore methods. This suggests that the offshore OIW readings are conservative.

Offshore monitoring of OIW will continue to be compared against the monthly NATA laboratory analysis total TRH and NEPM TRH. If the manual laboratory results exceed the NATA laboratory results (combined average of TPH totals), then the historical daily results will be reviewed to determine if the HACH manual analyser requires recalibration (Table 6-44). Any issues with the HACH manual analyser however would most likely be identified from the daily samples being compared against the inline OIW analyser.

6.7.6.7 *Discharge flow rates*

The PFW and ballast water discharge flow rates will be monitored via production averages. If flow rate trending towards exceeding the maximum PFW limit, production will be trimmed back on wells as required to not exceed the daily Unacceptable PFW limit.

The 24-hour total PFW volume, total produced liquids and ballast water discharged (via total oil volume) are reported on the Wandoo daily report for PFW and ballast water.

6.7.6.8 *Equipment calibration*

Equipment for monitoring of OIW, including calibration and cross-checking of laboratory equipment and inline OIW analysers, is regularly calibrated and tested in accordance with testing protocols that are compliant with American Society for Testing and Materials (ASTM) procedures.

6.7.6.9 *Adaptive management trigger criteria*

Metals, inorganics, alkylphenols and radionuclides

A variety of metals may be present in PFW in varying concentrations, therefore a suite of total and dissolved metals/metalloids have been selected to monitor annually. Where available, metals will be compared against ANZECC Water Quality Guidelines 95% and 99% species protection guideline values (Table 6-44).

There is no impact criteria for inorganics in Australian guidelines or legislation, therefore inorganic concentrations will be assessed against background levels. Ammonia concentrations exceed ANZECC Guidelines, therefore concentrations will continue to be monitored monthly and managed via the adaptive management strategy (Table 6-44).

Alkylphenols were added to the annual chemical testing suite in 2014. To date no alkylphenols have been detected within the PFW, however will continue to be monitored for detection.

Radionuclides have been assessed periodically within the Wandoo PFW since 1994. There is no impact criteria for radionuclides in Australian guidelines or legislation, therefore the assessment criteria for radionuclides is based on a comparison against background levels.

Hydrocarbons

O&G and TPH within the PFW sample will be monitored both monthly and annually. Concentrations will be assessed against background levels and used in the management of discrepancies between offshore manual sampling and the NATA laboratory results (Table 6-44).

PAH and BTEX concentrations will be sampled annually. To date, BTEX has not been detected within the Wandoo PFW since sampling was initiated in 1998. Small concentrations of PAH have been detected historically. However, no PAH analytes have been detected since 2012. PAH and BTEX concentrations will be assessed against the ANZECC Water Quality Guidelines 95% and 99% species protection guideline values (where available). If no guideline values exist, concentrations will be assessed against background levels.

Production chemicals

Production chemicals have not historically been assessed within the Wandoo PFW via chemical analysis. Alternatively, VOGA has a chemical assessment process to manage the risks and impacts associated with discharge of chemicals to the marine environment to ALARP during operational activities (see Section 7.11).

Although production chemicals may contain proprietary analytes unknown to VOGA, toxicity testing will continue to be undertaken annually to monitor for any increase in PFW toxicity and the requirement for further investigations (i.e. TIE assessments). Additional DTA analysis will be undertaken following any changes to the production process that could potentially change the PFW composition as per Table 6-44.

Corrosion inhibitor is the only process chemical whose concentration rate may exceed the product toxicity value. Quaternary amine compounds will be monitored annually.

Toxicity testing

Aquatic toxicity testing, by its nature, involves the dissolution of the PFW under test in the water media used and then maintenance of a stable bioavailable exposure concentration over the course of the test (UN GHS, 2011).

Every two years VOGA will undertake DTA testing (≥ 5 species) based on the ANZECC and ARM CANZ (2018) guidelines on the PFW effluent and compare against historical levels and undertake a desktop assessment against the annual NATA laboratory chemical analytes testing.

Every two years (alternating with DTA testing) VOGA will undertake an ecotoxicity screening test to compare against the most recent DTA test.

Based on the United Nations Globally Harmonized System (UN GHS), fish, molluscs and algae can be tested as surrogate species covering a range of trophic levels and taxa as a screening test. Alternatively, single species may be tested as a surrogate to detect increases in sample toxicity.

When undertaking screening tests routinely, or triggered as an adaptive response (Table 6-44), advice from the laboratory will be sought for the most appropriate species selection.

6.7.6.10 Adaptive management contingency actions

Appropriate contingency actions will be triggered via the adaptive management process within Table 6-44.

Should a significant increase in, or new impact or risk be identified that is not described or provided for by the accepted Wandoo Facility EP, then an ALARP and acceptability evaluation will be carried out to assess whether the existing control measures are sufficient to manage the impact or risk to ALARP and an acceptable level. No further action will be required if it is determined that there has not been a significant increase in impact.

Should the ALARP and acceptability evaluation determine that existing controls within the accepted Wandoo Facility EP do not manage the expected increase in, or new impact or risk to an ALARP and acceptable level, then additional controls including disposal, processing and engineering options are to be evaluated.

A revision of the Wandoo Facility EP is required for submission to NOPSEMA if significantly greater or new impact or risk is determined. That is, if an impact or risk is identified or expected from the proposed change to operations, but is not identified in the in the Wandoo Facility EP, then a revision of the Wandoo Facility EP will be submitted to NOPSEMA for assessment and acceptance, thus meeting the requirement of Regulation 17(6)(b).



Table 6-44: PFW and Ballast Water Adaptive Management Framework

Monitoring strategy	Trigger criteria	Contingency actions
OIW		
The PFW OIW are monitored continuously via an inline OIW analyser and two daily manual laboratory analysis.	OIW concentration exceeds the 'Unacceptable 24-hour Limit' for the PFW flow rate regime in operation, as per Table 6-39.	PFW is diverted inboard to Shaft 4 where it is diluted with ballast water.
	If the manual laboratory analysis significantly deviates from the inline OIW analyser instantaneous reading as per POM Procedure WNB-012-502	The inline OIW analyser will be cleaned (if not done so already) and an additional laboratory sample will be taken. If it still deviates, 4 hourly samples will be collected until inline OIW analyser is calibrated or repaired to within the required limits.
The ballast water OIW are monitored continuously via an inline OIW analyser and two daily manual laboratory analysis.	OIW concentration exceeds the 'Unacceptable 24-hour Limit' for the PFW flow rate regime in operation	Ballast water is diverted inboard until sufficient time has passed to lower the OIW to acceptable levels.
	If the manual laboratory analysis significantly deviates from the inline OIW analyser instantaneous reading as per POM Procedure WNB-012-502	The inline OIW analyser will be cleaned (if not done so already) and an additional laboratory sample will be taken. If it still deviates, 4 hourly samples will be collected until inline OIW analyser is calibrated or repaired to within the required limits.
An end-of-pipe PFW sample is taken on a monthly basis and analysed in a NATA accredited laboratory including hydrocarbons;	NATA laboratory results (combined average of TPH totals) significantly exceed the manual laboratory results.	The HACH manual analyser will be calibrated at the earliest convenience. Any issues with the HACH manual analyser however would most likely be identified from the daily samples against the inline OIW analyser.
PFW flow rate		
Flow is measured continuously via inline flow meter.	Flow rate discharge trending towards exceeding 'Maximum PFW 24-hour Limit' for the PFW flow rate regime in operation, as per Table 6-39.	PFW flow rate is tracked on production averages. If flow rate trending towards exceeding the 'Maximum PFW 24-hour Limit', production is trimmed back.



Monitoring strategy	Trigger criteria	Contingency actions
PFW chemistry and toxicity		
<p>An end-of-pipe PFW sample is taken on an annual basis and analysed in a NATA accredited laboratory.</p> <p>Parameters tested include:</p> <ul style="list-style-type: none"> • Metals; <ul style="list-style-type: none"> ○ Dissolved and total metals: Arsenic, Barium, Cadmium, Copper, Iron, Lead, Manganese, Nickel, Selenium, Strontium and Zinc. ○ Mercury, Total Chromium, Chromium Trivalent and Chromium Hexavalent. • Inorganics; <ul style="list-style-type: none"> ○ Chloride, Sulphide, Sulphite, pH, Total Organic Carbon, Total Dissolved Solids, Total Nitrogen, Total Suspended Solids and Turbidity. • Radionuclides; <ul style="list-style-type: none"> ○ Potassium-40, Radium-226, Radium-228 and Thorium-228. • Hydrocarbons; <ul style="list-style-type: none"> ○ O&G, Total TRH, NEPM TPH, PAH and BTEX. • Alkylphenols. • Production chemicals; 	<p>Metals Metal concentrations will be assessed against the ANZECC Water Quality Guidelines 95 % and 99% species protection guideline values (where available). If no guideline values exist, concentrations will be assessed against background and historical levels.</p> <p>Inorganics Inorganic concentrations will be assessed for anomalies or outliers, however no specific trigger levels will apply.</p> <p>Radionuclides As no Australian guideline values exist, radionuclide concentrations will be assessed against background and historical levels.</p> <p>Alkylphenols Phenol concentrations will be assessed against the ANZECC Water Quality Guidelines 95% and 99% species protection guideline values (where available). If no guideline values exist, concentrations will be assessed against background and historical levels.</p> <p>Hydrocarbons Hydrocarbon concentrations will be assessed against the ANZECC Water Quality Guidelines 95% and 99% species protection guideline values (where available). If no guideline values exist, concentrations will be assessed against background levels.</p> <p>Production chemicals As no Australian guideline values exist, quaternary amine compound concentrations will be assessed against their specific toxicity values.</p>	<p>If the assessment of the chemical analytes combined with toxicity test results identify a potential increase in PFW toxicity, a further screening test will be undertaken.</p> <p>If the potential for increased toxicity of the PFW stream remains, a DTA on the remaining species (not tested within the screening test) will be undertaken. A revised mixing zone will then be calculated for assessment against the Wandoo Facility EP defined mixing zone.</p> <p>If the new mixing zone is greater than the Wandoo Facility EP defined mixing zone, the requirement for further laboratory testing (i.e. TIE assessment) will be determined through an ALARP and acceptability assessment (as per Section 6.7.6.10).</p>



Monitoring strategy	Trigger criteria	Contingency actions
<ul style="list-style-type: none"> ○ Quaternary Amine Compounds. ● Ecotoxicity; <ul style="list-style-type: none"> ○ Screening test against the taxonomic groups: fish, mollusc and algae. 	<p>Ecotoxicity Toxicity concentration/s (species % effects data) will be assessed against species background levels.</p>	
<p>An end-of-pipe PFW sample is taken on a monthly basis and analysed in a NATA accredited laboratory including the ammonia constituents: N, NH4 and NH3.</p>	<p>Total ammonia Given historical measurements, total ammonia is likely to exceed the ANZECC Water Quality Guidelines 95% and 99% species protection guideline values. Therefore, further contingency actions will only be undertaken for a threshold level >50mg/L for total ammonia as N.</p>	
<p>Proposed production changes will be assessed for the following:</p> <ul style="list-style-type: none"> ● New production chemical proposed to be used in the PWTP. ● Target dosage concentrations of chemicals. 	<p>Production changes</p> <ul style="list-style-type: none"> ● New production chemical proposed to be used in the PWTP will be reviewed in accordance with the chemical assessment process outlined in Section 7.11. Contingency actions will be undertaken following any changes to the production process that could increase PFW toxicity, or introducing a new chemical that is more toxic than the chemical it is replacing ● Increase in the target dosage concentrations of chemicals approved for use in the production process that could increase PFW toxicity. 	<p>Initial assessment of potential for increased toxicity of the PFW is undertaken as per the impact assessment criteria for production chemicals in Section 3.3.3.6 If potential for increased toxicity is identified, then a screening test will be undertaken once the changes have been implemented (trialled via field change approval). If the screening test identifies potential increased toxicity of the PFW stream, the decision to implement the production change may be rejected. Alternatively, a DTA on the remaining species (not tested within the screening test) will be undertaken if the decision is to proceed. A revised mixing zone will then be calculated for assessment against the Wandoo Facility EP defined mixing zone If the new mixing zone is greater than the Wandoo Facility EP defined mixing zone, the requirement for further laboratory testing (i.e. TIE assessment) will be determined through an ALARP and acceptability assessment (as per Section 6.7.6.10).</p>



Monitoring strategy	Trigger criteria	Contingency actions
The toxicity of an end-of-pipe PFW sample is assessed on a two yearly basis.	<p>Ecotoxicity A mixing zone will be calculated based on DTA results to determine if it remains within the Wandoo Field EP defined mixing zone.</p>	If the new mixing zone is greater than the Wandoo Facility EP defined mixing zone, the requirement for further laboratory testing (i.e. TIE assessment) will be determined through an ALARP and acceptability assessment (as per Section 6.7.6.10).
Field monitoring within 12 months of EP acceptance to assess water and sediment quality at the boundary of the defined mixing zone	<p>Water quality, Sediment quality and Benthic infauna in accordance with Table 7-15 of this EP.</p>	If field monitoring results indicate that the mixing zone is in excess of the extent defined in this EP, a full ecotoxicity test will be required to detect any toxicity increases and the requirement for further laboratory testing (i.e. TIE assessment) will be determined through an ALARP and acceptability assessment ((as per Section 6.7.6.10). If the mixing zone increase is validated by the toxicity testing then management of change process will apply to assess the significance of the increase and subsequent actions (Section 7.8)

6.7.7 Risk ranking

PFW is consistently discharge into the marine environment with impacts assessed as localised and short term. Therefore, a consequence ranking of '1' and a likelihood of 'E' for a Medium risk was considered appropriate.

6.7.8 ALARP demonstration

6.7.8.1 Overview

The generation of PFW is critical to the production of hydrocarbons at Wandoo and there is an existing separation process and monitoring to minimise the OIW in the PFW discharge. Alternative controls have been considered as part of this risk assessment and options to further reduce OIW concentration form an integral part of VOGA's commitment to continuous improvement.

6.7.8.2 Review of impact levels

The potential impact to marine species is assessed to be short term and localised as there are no significant ecological populations or habitats that occur within the maximum extent of the whole effluent toxicity 99% species protection level that defines the mixing zone (3.65 km for the current scenario and 3.68 km for the proposed scenario). Frequency and duration analysis of the PFW stream showed that the threshold is exceeded up to within 600m for 99% of the time and at less than 6 hours continuous duration so it it considered highly unlikely that any impacts would extend past this distance.

There are BIA's present for mobile transient species such as turtles, sea snakes and whales which may be exposed to the PFW plume when surfacing for air but only for very short periods of time and with a low likelihood. The area of potential impact is minor in comparison to the area of the BIA. The duration of exposure within the PFW is low and these species are highly mobile and have the ability to swim and move in and out of the area of exposure. Exposure periods will be intermittent and highly unlikely to result in any long term impacts to key sensitivities.

The dilutions modelling is based on conservative inputs and has been validated by field monitoring.

The localised effect on water quality associated with PFW discharge will continue for the operational life of the Wandoo Facility. The PFW components are unlikely to result in any long term build-up of contaminants in the marine environment.

6.7.8.3 Existing controls

The hazard report (Section 6.7.1) and Section 6.7.6 describe the controls for this hazard. The range of controls includes multiple, independent layers of protection, including:

- PFW discharge flow rates are monitored;
- PFW can be diverted inboard to Shaft 4 (for a limited period of time);
- OIW concentration of both PFW and ballast water streams continuously monitored and alarmed in the CCR;

- Routine external laboratory testing is undertaken to ensure PFW chemistry is within assumed levels;
- Chemical dosing rates are monitored;
- Chemical assessment and selection process;
- Ballast water discharge overboard can be deferred to allow for fault finding;
- Instrument protective and alarm systems (interface level low level trips in production and second stage separators); and
- Produced Water Adaptive Management Strategy [WNB-7000-RP-0010].

6.7.8.4 OIW

System Improvements implemented

Given the generally low ballast water OIW concentration, the focus to manage and further reduce impact from OIW has been primarily on the PWTS.

When the Wandoo facilities were designed and commissioned, the most common method for disposal of PFW from offshore facilities was to process the PFW to regulatory requirements and discharge to sea. VOGA have expended considerable effort to improve the performance of the oil/water separation equipment thereby reducing the concentration of oil discharged to sea from the operating regulatory limit of 30mg/L to the current accepted target of 12.5mg/L for the current flow rate (32,000m³/d), and 11.1 mg/L for the proposed flow rate (36,000m³/d).

Since 2014 VOGA have implemented the following improvements:

- In 2016 a change was made to the primary method of quantifying OIW in PFW from 4-hourly laboratory results to the inline OIW analyser. The analyser provides real-time OIW values to the WNB CCR, captures spikes within the daily average and reduces bias in reporting. Actuals are logged and recorded within servers located on WNB (called the historian) with additional process values. This history can be recalled for OIW performance review.
- The Produced Water Adaptive Management Strategy [WNB-7000-RP-0010] was established in 2016 to capture and formalise the management, monitoring and continuous improvement of OIW levels within the PFW discharge.
- Bypass coalescer –agreed for implementation as a permanent change to the facility. As described in Section 6.7.8.4 the use of the coalescer has already been limited, this recommendation was therefore to permanently bypass the coalescer to avoid spikes in OIW concentrations.
- Additional inline OIW analyser for combined ballast water and PFW –implemented as part of PFW system upgrades in line with increased throughput. This measure allows for an independent check against the analysers on the individual PFW and BSW lines. This allows early detection of any analyser malfunction and avoidance of spikes in OIW concentrations.
- Divert ballast water to the IFSU –implemented as part of PFW system upgrades in line with increased throughput. This measure ensures that any OIWs in ballast water that may be diverted overboard could be recovered/minimised prior to discharge. This measure further reduces OIW concentrations in ballast water discharged overboard.

Capital projects implemented

To reduce environmental impact from OIW discharge, VOGA have conducted two phases of analysis. The first occurred in 2014 and was documented in Revision 8 of the Wandoo Facility EP, accepted in 2014. The second was conducted throughout 2015-16 which adopted the conclusion of the first analysis to find a suitable project to minimise PFW discharge impacts. Phase 2 was documented in Revision 12 of the Wandoo Facility EP; accepted by NOPSEMA in 2017.

Phase 1 reviewed a range of options to reduce impact from produced water. Outcome of the review was that reducing OIW concentration was most cost effective way to reduce impact. The impact reduction from reducing flowrate was significantly less and it had the highest cost.

In 2015-2016 VOGA continued to explore options to reduce the size of its PFW footprint by reducing the OIW content in the PFW. A project was initiated to “To maintain/enhance project economics and production profile whilst reducing environmental impact”.

The most practical solution identified to consistently reduce OIW is to convert an unutilised oil treatment vessel to a water treatment vessel, similar to the ISFU. The additional treatment vessel would run parallel to the existing ISFU maintaining sufficient residence time to enable oil and water separation and removal.

A concept selection was conducted, utilising the ALARP decision making framework in accordance with the VOGA Risk Management Manual [VOG-2000-MN-0001] and documented in a VOGA ALARP Demonstration Worksheet [WNB-3000-RY-0003]. Each case was assessed against the criteria required by the decision making process, as follows:

- Company values;
- Risk and impact based analysis;
- Societal values;
- Engineering judgement; and
- Good practice

The option of PFW flow rate at 32,000m³/day, was selected as the option that provided the best balance of risk reduction with increased flow rate.

The proposed upgrade was subjected to a further ALARP assessment to ensure that risks associated with this option are reduced to ALARP. This was included in an Environment Plan submission and accepted by NOPSEMA in 2017 (Revision 12).

Next phase of upgrades

Section 2.5.7.8 details how wells producing solids is a recent phenomenon on Wandoo and has resulted in OIW performance issues. A project was defined to provide a dedicated solids treat to limit OIW impacts, resulting in an increased produced water treatment and discharge capacity.

As part of the project review phase the change in environmental impact was conducted and is summarised in Section 6.7.5.7. Once Vermilion were satisfied that environmental impact change was minimal, focus shifted to optimising OIW performance.

The Wandoo oil and water separation processing train relies on three key aspects:

1. Chemicals to break down emulsions and aid separation of oil and water and solids.
2. Volume or residence time to allow the separation of oil, water and solids (separator residence time, particularly residence time within the Second Stage Separator).
3. Heat applied to the fluid entering the 2nd Stage Separator to aid oil, water and solids separation.

All three issues have been considered for the major components in the processing train to manage the solids and OIW performance to as low as reasonably practicable (ALARP). The objectives of the processing system upgrade are listed below and a process diagram available as Figure 2-6:

- Optimise the suite of chemicals throughout the processing train to maximise solids, oil and water separation.
- Dedicate the existing 1st Stage Production Separators, PS1 and PS2, to the current wells producing minimum solids.
- Bypass the CFUs to remove the hydrocyclone backpressure to enable each hydrocyclone to operate closer to their maximum flowrate.
- Provide an additional manifold dedicated to solids producing wells. Provision in the total manifold system will allow the flexibility to allow future flowrate balancing and optimisation of performance between most of the wells and production separators.
- Provide an additional 1st Stage Production Separator, PS3, dedicated to solids producing well production.
- Install hydrocyclones on the new PS3 to treat the separated produced water prior to final polishing in the ISFU's.
- Operate the Test Separator as a 3-phase separator and direct the separated PFW to PS3. The remaining oil/water to be directed to 2SS.
- Reduce the flowrate of water carried over to the 2nd Stage Separator, to provide more residence time and allow the process heater(s) to increase and optimise the temperature of fluid entering the vessel. The existing process heaters will then be capable of heating this stream by an additional 10°C, to over 70°C.
- Ensure that the temperature of the produced water routed to ISFU2 is below 60°C.
- Provide on-line solids removal manifolds in PS3 and 2SS. Route the solids to a storage system.
- Provide a solids storage and handling system capable of collecting and treating the solids so that it can be stored for transportation and disposal onshore.
- The two ISFU's have the capability to separate oil and water up to 18 ML/d each with a 90% efficiency. This will enable an improved OIW concentration of 11.1 mg/L or lower at a maximum PFW throughput of 36 ML/day

Further process enhancements have been proposed to manage the OIW to ALARP as follows:

- A well manifold arrangement was incorporated to allow well optimization and flowrate balancing in the three 1st Stage Separators. Maximising the vessel residence time will ensure the separators process the PFW OIW outlet to as low as possible.

- Consideration of bypassing of the CFU separators or installing them in parallel was undertaken for both the 2017/18 and proposed upgrades with the option to bypass selected given the improved OIW performance. With the bypassing of the CFU separators, hydrocyclones have more pressure drop available to be able to optimize their performance and achieve a higher separation efficiency. If a separation efficiency of 90% was achieved this would have a knock-on effect of reducing the overboard OIW.

A production and produced water system upgrade to handle solids and improve OIW performance was proposed that built on previous analysis (Phases 1 & 2) and the 2017/18 upgrade that increased production and reduced OIW to achieve ALARP for the produced water discharge impacts.

The most practical solution identified was the installation of a separate solids removal system. The proposed process and produced water upgrades are detailed in Section 2.5.7.8.

Conclusion

The proposed PFW volume increase and associated decrease in the performance target for OIW concentration results in the following outcomes which are considered ALARP for the hazard:

- Potential impacts remaining short term and localised to within approximately 600m of the discharge with frequency and duration considered.
- No increase to the total volume of oil entrained in the PFW per day.
- Potential impacts from hydrocarbons being similar or even slightly reduced.

6.7.8.5 Ammonia

Since 2013 VOGA has conducted a series of assessments to understand the nature and scale of the environmental impact from ammonia discharge, which has resulted in increased field sampling and a revised impact assessment.

To reduce the impact from total ammonia within the PFW, the amount discharged needs to be reduced by either reducing the volume discharged or reducing the concentration. Concentration reduction is the preferred means of impact reduction as the discharge velocity, a function of the flow rate, is an important factor in supporting dilution through the mixing zone.

Options to reduce the total ammonia concentration in PFW have been considered and these include:

- Option 1: treating/dosing the PFW to either impact the ammonia/ammonium dissociation;
- Option 2: treat or dose the PFW to consume the ammonia/ammonium through a reaction; and
- Option 3: filtering the total ammonia from the PFW prior to discharge through molecular sieves.

Although these three options are utilised in some industries (including oil and gas) to remove total ammonia the application is limited to either low flow rates (up to 1,000m³/day) or onshore operations with production at higher rates. Therefore, significant investment and research is required to scale the process to an offshore application with a sufficient flow rate which can reduce impact; this is particularly the case for Options 2 and 3.

These options have been assessed in Produced Formation Water Environmental Impact Assessment [AE15009-VOG-1000-RH-0001] and considered not viable as:

- Involves a significant capital and operating cost with a negligible impact reduction as only a small proportion of the proportion of the produced formation water is able to be treated;
- May either introduce new environmental impacts, increase existing impacts as potential chemicals suitable for dosing are either toxic to marine life or may negatively impact integrity of process vessels and piping;
- Outcome is no different than not treating it as the total ammonia may be unchanged; or
- The discharge will be the same as the breakdown products of ammonia, a process which naturally occurs in the seawater.

Reducing the PFW flow rate is not a reasonably practical option as the existing impact is limited and reducing it further through flow rate limits is disproportionate benefit compared to the cost. Reducing flow rate would reduce the dilution rates for all products and have impacts on the economic life of the asset. Whilst increasing the flow rate increases the potential maximum distance of dispersion for ammonia, changes in potential impacts are negligible as assessed in Table 6-43.

The management of total ammonia impact to environment is considered ALARP as:

- Impacts due to total ammonia considered to be acute and limited in range and duration;
- Ammonia is oxidised or degrades naturally in the seawater as part of the ammonia lifecycle, allowing it to be consumed within the environment;
- Whilst additional PFW flow rate may increase the total ammonia discharged, the offset in impact reduction from the OIW as hydrocarbons in PFW are more persistent and likely to impact on marine sensitivities than other components; and
- The available options to manage the hazard of total ammonia discharge, involve a significant capital and operating cost and will have a limited impact reduction, at best, which is disproportionate to the investment.

6.7.8.6 Temperature

Near-field temperature modelling results found that there would be minimal predicted increase in temperature impacts for all production scenarios. Therefore, for all increased production rates there is no increase in risk and all scenarios are considered to have risk levels which are ALARP in terms of temperature impacts.

6.7.8.7 Production chemicals

Production chemicals are an essential requirement of the production process to ensure operational efficiency in the production of hydrocarbons. The primary means of reducing impact are through the careful selection and use of chemicals that are low risk to the environment. The quantity of the chemicals used is carefully managed as optimal doses are required to maintain production. Overuse of chemicals is discouraged because it can affect production, adds to the cost of production and because of the potential impacts to the marine environment.

VOGA reviews existing Wandoo process chemicals to identify whether suitable alternatives are available that potentially have a lower environmental impact. The review is conducted in

accordance with the ALARP justification process outlined as part of the VOGA chemical selection process in Section 6-46.

6.7.8.8 Conclusion

The ALARP assessment has concluded that the risks are being managed to ALARP because:

- Since VOGA have operated the Wandoo Facility, existing controls and monitoring applied over time have identified and achieved OIW performance improvements;
- Reduction in water throughout is not a reasonably practical measure to reduce the environmental impact as the impact area is sensitive to the output velocity of the PFW-ballast water discharge;
- The Produced Water Adaptive Management Strategy [WNB-7000-RP-0010] has been implemented to improve implementation of existing controls and provide formalised a continuous improvement cycle;
- Proposed modifications will further reduce impacts from OIW and all other constituents will remain consistent;
- Impacts due to total ammonia considered to be acute and limited in range and duration and options to reduce the concentration are not reasonable or practical; and
- Ongoing review and approval of new process chemicals in accordance with the chemical assessment process outlined in Section 7.11 to ensure impact zone is consistent with the current risk profile and where possible identify alternative chemical arrangements with lower environmental impacts.

6.7.9 Acceptability demonstration

The assessment undertaken to date has relied on multiple lines of evidence (i.e. PFW modelling, Ecotox testing of PFW, chemical characterisation, field-based validation of modelling) to demonstrate that the environmental impacts associated with the discharge of PFW are having no discernible impact on the receiving environment or on sensitivities that may be exposed to the PFW. Similarly, the continuous discharge is unlikely to pose a threat to the marine environment as the modelling indicates that the spatial extent of the potential impact of the discharge is limited to 3.68km and with frequency and duration considered, highly unlikely to result in impacts outside 600m.

VOGA have consulted stakeholders with social and economic interests within close proximity to our Operational Area and outlined our current and proposed produced formation water discharge. To date we have received no objections to the current and proposed activity as described within this Wandoo Facility EP.

Other regional field studies, e.g. Burns and Codi (1999) have also confirmed that there is no evidence to support increasing (hydrocarbon) inventories in the water column or the surface sediments over time associated with PFW discharge. Thus, the losses by dilution, evaporation, microbial degradation and photo-oxidation of the hydrocarbons, remove the inputs on a near daily basis. On this basis, there is very little likelihood of cumulative impacts either associated with the continuous discharge of PFW and ballast water from WNB.



6.8 Introduction of invasive marine pests

6.8.1 Hazard report

Table 6-45: Hazard report – Introduction of invasive marine pests

HAZARD:	Introduction of invasive marine pests					
EP risk no.:	EP-OP-R21					
Potential impacts:	Potential introduction and establishment of invasive marine pests. Changes to habitat structure. Predation of native species.					
PREVENTION:						
Activity/cause:	Existing management controls	Control type	Control hierarchy	Performance outcome	Performance standard	Measurement criteria
Ballast water from tankers and vessels	Pursuant to the Biosecurity Act 2015 and Australian Ballast Water Management Requirements 2017, support vessels carrying ballast water and engaged in international voyages shall manage ballast water so that marine pest species are not introduced.	Administrative	Prevention	No Invasive Marine Species established on project infrastructure or in the natural environment as a result of the petroleum activities	Vessels will have a valid ballast water management certificate, unless an exemption applies or is obtained, as specified in the Australian Ballast Water Management Requirements.	Valid ballast water management certificate or record of exemption
Biofouling on vessels and equipment	Vessel and immersible equipment complete the VOGA Biofouling Risk Assessment Process consistent with National Biofouling Guidelines for the Petroleum Production and Exploration Industry and IMO Guidelines for the control and management of a ships' biofouling to minimise the transfer of invasive aquatic species.	Administrative	Prevention		Vessels will complete a VOGA Biofouling Risk Assessment , identifying a low risk before mobilisation to the Operational Area: Biofouling risk based on a range of information including presence of a biofouling management plan and record book, last port of call, age of anti-fouling coating etc. If a risk category of moderate, uncertain or high is scored, the process requires an independent IMS expert to be engaged and further risk assessment and/or management measures undertaken	Records of VOGA Biofouling Risk Assessments maintained for all vessels and relevant immersible equipment entering the Operational Area demonstrating low risk status. Records of management measures implemented if required, through the IMS vessel risk assessment process
	Anti-foulant system	Administrative	Prevention		Anti-fouling Systems on tankers and vessels are maintained in compliance with International Convention on the Control of Harmful Anti-Fouling Systems on Ships (IMO, 2001): <ul style="list-style-type: none"> Prohibits the use of harmful organotins in antifouling paints used on ships and establishes a mechanism to prevent the potential future use of other harmful substances in anti-fouling systems. 	Records indicate ship anti-fouling systems have not used harmful organotins.
				IMS inspection of project infrastructure to validate absence of invasive marine pests on a 5 yearly basis (commencing 2021).	IMS inspection records	
MITIGATION:						
Existing management controls	Control type	Control hierarchy	Performance outcome	Performance standard	Measurement criteria	
None identified.	N/A	N/A	N/A	N/A	N/A	
INITIAL RISK WITH EXISTING CONTROLS:						
Consequence	Likelihood (of consequence)			Initial risk		



INITIAL RISK WITH EXISTING CONTROLS:					
Major (4)		Unlikely (B)		Medium risk	
ADDITIONAL CONTROLS/DEMONSTRATION OF ALARP - VOGA WORKSHOP:					
A Medium risk is defined as tolerable on demonstration of ALARP under the VOGA risk level action criteria. The following ALARP analysis provides assurance that all risk treatment options have been considered.					
Additional management controls		Assessment of option		Adopted/Not adopted	
Restrict vessel operations to using vessels and equipment that have only operated in local, State or Commonwealth waters to reduce potential for invasive marine species.		Would reduce potential for invasive marine species to be transported into area since vessels would not have originated elsewhere. Vessels and equipment suitable for the activity that have only operated in local, State or Commonwealth waters may not be available; therefore, work could not be completed		Not adopted	
Mandatory dry docking of vessels prior to entering field to clean vessel and equipment and remove biofouling.		Would ensure that no invasive marine species are present on vessel or associated equipment. Significant cost (grossly disproportionate to the risk); would lead to scheduling delays.		Not adopted	
Biofouling Management Plans in place for all vessels		Requiring each vessel to have an in place biofouling management plan and record book was not adopted given: <ul style="list-style-type: none"> • The presence of a biofouling management plan and record book is part of the Biofouling risk assessment process and so will inform the risk level assigned and any actions. • A biofouling management plan is best practice however not currently a legal requirement and as such not all vessels have this in place. This could lead to delays if ad hoc vessels are required and given the measure is part of the risk assessment process, not considered essential. 		Not adopted	
RESIDUAL RISK AFTER ADDITIONAL CONTROLS:					
Consequence		Likelihood (of consequence)		Residual risk	
Major (4)		Unlikely (B)		Medium risk	
ACCEPTABLE LEVEL OF RISK DEMONSTRATED:					
Principles of ESD not compromised	External Context – objects or claims considered	Internal Context – VOGA HSE / procedures met	Other Requirements met	RR < High (RRII)	EPO(s) manage risk to acceptable level(s)
Relevant principles of ESD not compromised given proposed controls	N/A – no external objections or claims received	Yes – Risk managed in accordance with VOGA HSE policy and procedures.	Yes – Biosecurity Act 2015 and Australian Ballast Water Management Requirements 2017; National Biofouling Guidelines for the Petroleum Production and Exploration Industry and IMO Guidelines for the control and management of a ships' biofouling International Convention on the Control of Harmful Anti-Fouling Systems on Ships (IMO, 2001):	Yes – RRIII (Medium)	Yes – EPOs specify no establishment of IMS. The following relevant overarching EPOs (Section 3.4) maintained providing control measures maintained: <ul style="list-style-type: none"> • EPO-OP-15

6.8.2 Description of hazard

Biofouling on immersed surfaces (e.g. ship hulls), floating/ immersible equipment and within internal seawater circulation systems, as well as ballast water, are potential pathways for invasive marine species (IMS) to translocate on offshore vessels.

There is the potential for vessels to transfer IMS from international waters into the Operational Area and for them to establish on project infrastructure and in the local environment. There is a smaller risk of transfer of IMS from Australian waters.

6.8.2.1 *Ballast Water*

The Commonwealth Department of Agriculture, Water and the Environment (DAWE) is the lead agency for management of ballast water, with responsibility (formerly the Department of Agriculture). Vessels manage ballast water in accordance with International Maritime Organisation (IMO) Ballast Water Management (BWM) Convention, IMO Guidelines, the mandatory Australian Ballast Water Management Requirements (DAWR, 2017) that is enforced under the Biosecurity Act 2015 and associated local measures intended to minimise the risk of transplanting harmful aquatic organisms and pathogens from ships' ballast water and associated sediments, while maintaining ships safety.

The Australian Ballast Water Management Requirements set out the obligations on vessel operators with regards to the management of ballast water and ballast tank sediment when operating within Australian seas.

The requirements provide guidance for vessel operators on best practice policies and apply to all vessels operating internationally and domestically in Australia.

- All vessels must carry a valid ballast water management plan
- All vessels must carry a valid International Ballast Water management certificate
- Vessels with a ballast water management system (BWMS) must carry a Type Approval Certificate specific to the type of Ballast Water Management System (BWMS) installed
- All vessels must maintain a complete and accurate record of all ballast water movements

Vessels that are intending to discharge internationally sourced ballast water must submit a Ballast Water Report through MARS at least 12 hours prior to arrival.

Domestic vessels that have been released from biosecurity control are still required to manage the movement of Australian sourced ballast water.

All ballast water should be managed using one of the approved ballast water management options. All ballast water must be managed or receive a low risk exemption from the department prior to discharge.

6.8.2.2 *Biofouling*

The Commonwealth Department of Agriculture, Water and the Environment is the lead agency for management of Biofouling on vessel hulls, external niche areas and immersible equipment pose a potential risk of IMS in Australian waters. Under the National Biofouling Management Guidance for the Petroleum Production and Exploration Industry and IMO Guidelines for the control and

management of ships' biofouling to minimise the transfer of invasive aquatic species (resolution MEPC.207(62), DAWE and DoEE guidelines, a risk assessment approach is applied to manage biofouling. IMO biofouling guidelines are considered 'best practice' for mitigation of transfer of invasive aquatic species to ALARP.

All contracted vessels are required to complete the VOGA Biofouling Risk Assessment Process described in Section 7.12. The VOGA Biofouling Risk Assessment Process assigns a final risk category of low, moderate, uncertain or high to vessels based on a range of information including last port of call, age of antifouling coating etc. If a risk category of moderate, uncertain or high is scored, a range of management options are available including inspections, cleaning or treatment of internal seawater systems.

The following Wandoo-to-vessel interactions are exempted from this risk assessment:

- Crude offtakes to tankers via the export system (CALM Buoy);
- Transfer of Mooring master to support vessels during pilotage of offtake tankers;
- Offloading of equipment from another vessel onto the platforms, but the equipment will be deployed directly to the seabed.

6.8.3 Impact assessment

6.8.3.1 Sensitive receptors

Marine invertebrate communities, marine mammals, marine reptiles, fish, commercial fishing, and offshore infrastructure.

Despite the potential high consequence of the establishment of a marine pest within a high-value environment, like coastal or sheltered nearshore waters, the deep offshore open waters of the Operational Area are not conducive to the settlement and establishment of IMS (Geiling 2014), due to the lack of light or suitable habitat to sustain growth or survival. The facility is located on the NWS, ~40 km distant of Glomar Shoal in waters >50m deep.

It is unlikely that any invasive marine species would survive and spread from the Wandoo facilities, given the seabed substrate (bare sand), lack of hard substrate within close proximity from Wandoo, and limited light availability at the seabed. The greatest potential for invasive marine species colonisation would be on subsea infrastructure (providing attachment points for sessile invertebrates) closer to the sea surface where light availability is greater.

6.8.3.2 Impact assessment criteria

Settlement of invasive marine species on Wandoo infrastructure or surrounds resulting in localised impacts on native marine fauna and flora.

6.8.3.3 Impacts

The introduction and establishment of invasive marine species can result in a localised impact on native marine fauna and flora and include:

- Competition, predation or displacement of native species;
- Alteration of natural ecological processes;
- Introduction of pathogens with the potential to impact on human and/or ecological health;

- Reduction and/or competition with commercial fish and aquaculture species; and
- Increased maintenance of vessels and marine infrastructure.

The discharge of ballast water contaminated with hydrocarbons may cause:

- Reduction in water quality (pollution) of the surrounding surface waters; and
- Acute toxicity to marine fauna in the immediate vicinity of the discharge.

6.8.3.4 *Impact description*

Invasive marine species

Invasive marine species are organisms that have established within a marine environment outside of their natural area of distribution and impact on local ecosystems. Not all marine species introduced into an area have the potential to establish themselves and become invasive. Species of concern are those that are not native to the region, are likely to survive and establish in the region, and are able to spread by human mediated or natural means. Species of concern vary from one region to another depending on various environmental factors such as water temperature, salinity, nutrient levels and habitat type. These factors dictate their survival and invasive capabilities.

Studies have found that most introduced marine species are temperate. Of the 60 species known to have become established in WA, only six are tropical species that occur north of Shark Bay (Wells *et al.*, 2009). Most introduced marine species are concentrated in port areas and relatively few have expanded their range beyond these presumed introductory points (Wells *et al.*, 2009). Consequently, the introduced marine pests that have established in WA marine waters have, so far, only resulted in changes to faunal assemblages of highly localised port areas, with few repercussions for the broader marine environment.

Due to the deepwater, open-ocean environment at the Wandoo facilities, it is anticipated there will be little potential for pest organisms to accumulate and multiply due to lack of habitat. The greatest potential for the introduction of a marine pest species is the colonisation of subsea infrastructure by fouling organisms, particularly sessile invertebrates or marine algae closer to the sea surface, where light availability is greater. Due to the relative isolation of the Facility, any introduction is likely to remain localised.

Although the chance of an introduction is relatively low, once a marine pest population is established, eradication is often impossible, limiting management options for ongoing control or impact minimisation. For this reason, increased management requirements have been implemented by Commonwealth and State agencies in recent years, with the implementation of Australia's National System for the Prevention and Management of Marine Pest Incursions (the National System) and the Commonwealth *Biosecurity Act 2015* and associated regulations.

In the event that an introduced marine species colonises the environment as a result of Wandoo activities, a control strategy will be developed and implemented, in consultation with invasive marine species experts and the Department of Agriculture and Water Resources.

Contaminants

Potential impacts associated with any discharge of oil-contaminated ballast include temporary reduction of water quality near the release point, and the potential for toxicological impacts to marine flora and fauna through contact with surface hydrocarbon concentrations.

The potential impacts of discharges of oily water on water quality and marine fauna are discussed in detail in Section 6.15.3. Dispersion and dilution is expected to be rapid, resulting in short-term changes in water quality.

The greatest risk at the project location will be to plankton and pelagic fish. However, given the biodegradability/low persistence of the wastes, and the minimal volumes involved, the impact on the surrounding water quality would be temporary and localised. As a result, it is not expected that marine fauna or plankton will be exposed to chemicals or hydrocarbons in quantities that would induce acute or chronic toxicity impacts.

6.8.4 Risk ranking

A consequence ranking of '4' (Major) and a likelihood of 'B' (Unlikely) was considered appropriate resulting in a residual risk ranking of Medium.

6.8.5 ALARP and acceptability demonstration

A review of the risks and impacts to determine that the risks are acceptable and ALARP has assessed that:

- Vessel traffic within the field is required for operations and maintenance of the Wandoo facilities; their presence in the field is intermittent;
- The majority of supply and support vessels are from within Australian waters; therefore, the frequency of this risk is further reduced; and
- All vessels in the Wandoo Field undertake a VOGA Biofouling Risk Assessment.

An alternative is for VOGA to carry out hull inspections of all vessels that will be used prior to them entering the Operational Area. However, this would require the vessels to be moved to a suitable location for inspection, this additional step will not reduce the environmental risks associated with the operations, but it will increase health and safety risks and is not practical from a logistics and cost perspective. Vessel inspection or cleaning is not warranted given the mitigation measures in place

Requiring each vessel to have an in place biofouling management plan and record book was considered however due to the following this was not adopted:

- The presence of a biofouling management plan and record book is part of the Biofouling risk assessment process and so will inform the risk level assigned and any actions.
- A biofouling management plan is best practice however not currently a legal requirement and as such not all vessels have this in place. This could lead to delays if ad hoc vessels are required and given the measure is part of the risk assessment process, not considered essential.

As the majority of support vessels that visit Wandoo are from Dampier, the risk of invasive marine species introduction is very low. Environmental conditions at the site are also not conducive to the establishment of invasive marine species due primarily to the lack of suitable habitat.



6.9 Non-hazardous and hazardous waste

6.9.1 Hazard report

Table 6-46: Hazard report – Non-hazardous and hazardous waste

HAZARD:	Non-hazardous and hazardous waste					
EP risk no.:	EP-OP-R14					
Potential impacts:	Marine pollution (litter). Injury and entanglement of marine fauna and seabirds. Potential toxicity effects to marine fauna. Land and onshore groundwater contamination.					
PREVENTION:						
Activity/cause:	Existing management controls	Control type	Control hierarchy	Performance outcome	Performance standard	Measurement criteria
Generation of recyclable waste (non-hazardous), e.g. paper, cans, glass recyclable scrap metal.	Recyclable material bins are provided on the facility for segregated recyclable waste and waste sent to a licensed waste contractor for disposal.	Engineering	Reduction	Maximise recycling of waste from Wandoo Facility to minimise landfill and incineration.	Recyclable material collected in dedicated bins and sent to a licensed waste contractor for disposal in accordance with the Waste Management Procedure [WPA-7000-YH-0009]	Platform visual inspection checks and waste manifests.
Generation of general (non-hazardous) waste.	Solid inert (general) waste bins provided on the facility with waste sent to a licensed waste contractor for disposal.	Engineering	Reduction	Ensure that general (non-hazardous) waste is appropriately disposed of.	Inert solid waste material collected in dedicated bins and sent to a licensed waste contractor for disposal in accordance with the Waste Management Procedure [WPA-7000-YH-0009].	Platform visual inspection checks and waste manifests.
Generation of hazardous waste.	Solid low-level hazardous waste bins provided on the facility with waste sent to a licensed waste contractor for disposal.	Engineering	Reduction	Hazardous waste is handled, stored and disposed of in an appropriate manner, to minimise impact to the environment without exposing personnel to unacceptable risks.	Solid low-level hazardous waste is collected in bins provided and sent to a licensed waste contractor for disposal in accordance with the Waste Management Procedure [WPA-7000-YH-0009].	Platform visual inspection checks and waste manifests.
	Waste oils and contaminated water drums provided on the facility. Content is recycled for oil separation and drums are recycled by a licensed waste contractor.	Engineering	Reduction		Waste oils and contaminated water waste is collected in bins provided and content is recycled for oil separation and drums are recycled by a licensed waste contractor in accordance with the Waste Management Procedure [WPA-7000-YH-0009].	
	Slop crude oil is reprocessed through WNB process.	Engineering	Reduction		Slop crude oil is reprocessed through WNB process.	
	Greases collection drums are provided on the facility and waste is sent to a licensed waste contractor for disposal.	Engineering	Reduction		Greases are collected in bins provided and are sent to a licensed waste contractor for disposal in accordance with the Waste Management Procedure [WPA-7000-YH-0009].	
	Waste drums are provided for the collection of miscellaneous chemical waste (including laboratory waste, corrosion inhibitor, acids, alkalis, biocides adhesives), and waste is sent to a licensed contractor.	Engineering	Reduction		Miscellaneous chemical waste (including laboratory waste, corrosion inhibitor, acids, alkalis, biocides adhesives), is collected in waste drums and sent to a licensed contractor in accordance with the Waste Management Procedure [WPA-7000-YH-0009].	



Activity/cause:	Existing management controls	Control type	Control hierarchy	Performance outcome	Performance standard	Measurement criteria
	Waste drums are provided for the collection of flammable liquid wastes, production sand and process sludge and waste is sent to a licensed waste contractor for disposal.	Engineering	Reduction		Flammable liquid wastes, production sand and process sludge are collected in drums and sent to a licensed waste contractor for disposal in accordance with the Waste Management Procedure [WPA-7000-YH-0009].	
	Dedicated bins are provided on the facility for medical waste and waste is sent to third party medical facility for disposal.	Engineering	Reduction		Medical waste is collected in dedicated bins and sent to third party medical facility in accordance with the Waste Management Procedure [WPA-7000-YH-0009].	
	Skips storing loose solid material either have lids or are covered by tarps in high wind conditions.	Engineering	Prevention	Minimise waste entering the marine environment during storage or transfer.	Open-top skips/bins are covered in high wind conditions in accordance with the Waste Management Procedure [WPA-7000-YH-0009].	Platform visual inspection checks skips with loose solid waste.
	Liquid containers are closed for transport.	Engineering	Prevention		Liquid containers are covered for transport in accordance with the Waste Management Procedure [WPA-7000-YH-0009].	Platform visual inspection liquid containers prior to transport.
Subsea maintenance generating solid non-hazardous waste (e.g. grout, metal filings).	Grout selection process will include lowest toxicity.	Administrative	Reduction	Manage the risk to the marine environment caused by use of grout via grout selection.	Grout selection and approval process is documented.	Records of selection and approval.

MITIGATION:						
Existing management controls	Control type	Control hierarchy	Performance outcome	Performance standard	Measurement criteria	
None identified.	N/A	N/A	N/A	N/A	N/A	N/A

INITIAL RISK WITH EXISTING CONTROLS:		
Consequence	Likelihood (of consequence)	Initial risk
Incidental (1)	Almost Certain (E)	Medium risk

ADDITIONAL CONTROLS/DEMONSTRATION OF ALARP - VOGA WORKSHOP:		
A medium risk is defined as tolerable on demonstration of ALARP under the VOGA risk level action criteria. The following ALARP analysis provides assurance that all risk treatment options have been considered.		
Additional management controls	Assessment of option	Adopted/Not adopted
Install processing facilities on the facility, capable of very high temperature incineration of all wastes, including hazardous wastes.	Installation of waste processing facilities on the platform is not feasible considering personnel and equipment safety and space allocation. This would also involve significant cost, for a negligible reduction in environmental risk and potential environmental impact.	Not adopted

RESIDUAL RISK AFTER ADDITIONAL CONTROLS:		
Consequence	Likelihood (of consequence)	Residual risk
Incidental (1)	Almost Certain (E)	Medium risk

ACCEPTABLE LEVEL OF RISK DEMONSTRATED:					
Principles of ESD not compromised	External Context – objects or claims considered	Internal Context – VOGA HSE / procedures met	Other Requirements met	RR < High (RRII)	EPO(s) manage risk to acceptable level(s)
Relevant principles of ESD not compromised given proposed controls	N/A – no external objections or claims received	Yes – Impact managed in accordance with VOGA HSE policy and waste procedures.	Yes – MARPOL 73/78	Yes – RRIII (Medium)	Yes – EPOs specify that waste is managed in accordance with VOGA procedure. The following relevant overarching EPOs (Section 3.4) maintained providing control measures maintained: EPO-OP-01; EPO-OP-04; EPO-OP-05; EPO-OP-06; EPO-OP-07; EPO-OP-08; EPO-OP-09; EPO-OP-10; EPO-OP-11; EPO-OP-12; EPO-OP-13

6.9.2 Description of hazard

Wastes generated at the Wandoo Facility are divided into two streams:

- Non-hazardous waste (general and recyclable); and
- Hazardous waste.

Recyclable waste generated at the Facility includes aluminium cans, glass, paper and recyclable scrap metal.

General waste includes general waste material (including wood) and putrescible waste which comprises galley waste, sewage and greywater. The discharge of putrescible waste is outlined in Section 6.16.

Hazardous wastes generated at the Facility may include:

- Solid hazardous waste such as insulation waste, batteries, empty paint cans, empty drums, and hydrocarbon-contaminated materials such as oil filters;
- Liquid hazardous waste such as liquid hydrocarbon wastes (oily water, grease, etc.) and miscellaneous chemical waste such as acids and solvents; and
- Produced sands which are generated on the Wandoo Platform from the reservoir, consisting of fine sand and glauconite containing oil and some heavy metals. The sands have a median particle size of approximately 120µm and settle out in the separators where they are regularly flushed. The dry sands are transported back to the mainland.

Waste associated with the Wandoo operations is managed according to the Waste Management Procedure [WPA-7000-YH-0009] which is aimed at appropriately managing waste stream to limit the impact to the environment.

There may be accidental releases/discharges to the marine environment of non-hazardous and hazardous solid wastes (i.e. littering or dropped objects) from the Platform or other vessels during operational activities due to deviation from procedures, poor equipment maintenance, inadequate staff training, or adverse weather conditions (e.g. storm that results in goods rolling or blowing off decks). The amount of refuse generated averages 5 to 6t per month.

The types of hazardous wastes listed above may be accidentally discharged and lead to potentially toxic effects on marine fauna. The inappropriate discharge of hazardous wastes onshore (i.e. illegal dumping or disposal to an unauthorised landfill that is not properly lined) may also result in those wastes creating land and/or groundwater contamination.

Accidental loss of containment of sand into the ocean may also occur from equipment failure, incorrect handling and/or transport and overfilling of sands tanks.

The build-up of scale, which is the precipitation of solid minerals from the PFW potentially containing Naturally Occurring Radioactive Materials (NORMs), may occur in flowlines and process equipment. This build-up is removed periodically and requires onshore disposal. Scrap metal (used pipe/spools) and used electrical submersible pumps from the production system may also contain NORMs.

6.9.3 Impact assessment

6.9.3.1 Sensitive receptors

Pelagic habitat and species (fish and plankton), marine mammals, marine reptiles, seabirds, and benthic habitat.

6.9.3.2 Impact assessment criteria

Hazardous and non-hazardous waste minimised, recycled, reused and appropriately disposed of to reduce the impact to the marine environment.

6.9.3.3 Impacts

The potential environmental impacts of non-hazardous and hazardous solid waste to marine and terrestrial environments are:

- Marine pollution (litter);
- Injury and entanglement of marine fauna and seabirds;
- Potential toxicity effects to marine fauna; and
- Land and groundwater contamination.

6.9.3.4 Impact description

Non-hazardous waste

If accidentally discharged overboard (i.e. dropped object during vessel transfers), solid wastes can cause smothering of benthic habitats as well as injury or death to marine fauna or seabirds through ingestion or entanglement (e.g. turtles mistaking plastics for jellyfish, rope getting caught around the necks of marine fauna and seabirds). No discharge of solid waste is expected during normal operations.

All waste will be segregated, stored in sealed containers and labelled. It will then be returned to the mainland for disposal or recycling onto support vessels in closed containers/skips/bins, tanks or 'bulky-bags', in accordance with VOGA's Waste Management Procedure [WPA-7000-YH-0009]. As such, the risk of potential impact associated with the discharge of solid waste is expected to be minimal.

Furthermore, the benthic habitat in the Operational Area primarily comprises bare sediments, and as such any impacts of garbage would be negligible, however if an incident was to occur, VOGA would seek to retrieve the dropped object(s).

Hazardous waste

The potential impacts of hazardous solid wastes are contamination of the marine environment including localised changes to water quality and toxic effects on marine species.

Items of solid hazardous waste, such as paint cans containing paint residue, or batteries, would settle on the seabed if dropped overboard. Over time, this would result in the leaching of hazardous materials to the seabed, which is likely to result in a small area of substrate becoming toxic and unsuitable for colonisation by benthic fauna.

The impacts of liquid hazardous wastes such as hydrocarbons and chemicals on the marine environment are described in Section 6.20. A detailed description of the impacts of hydrocarbons on the marine and social environment is provided in Section 6.2.3.

The inappropriate discharge of hazardous wastes onshore (i.e. illegal dumping or disposal to an unauthorised landfill that is not properly lined) may also result in those wastes creating land and/or groundwater contamination.

Given all waste will be disposed of at appropriately licensed facilities, no impacts are predicted from non-hazardous solid and hazardous waste generated from the operation of the Wandoo Facility.

6.9.4 Risk ranking

The potential for waste to be accidentally discharged overboard is likely to be more than once a year, with a likelihood of 'E' and a consequence ranking of '1' (Incidental) ranking for Medium risk.

6.9.5 ALARP and acceptability demonstration

A review of the risks and impacts to determine that the risks are ALARP has assessed that:

- Waste associated with the Wandoo operations is managed according to the Waste Management Procedure [WPA-7000-YH-0009] which is aimed at appropriately managing waste stream to limit the impact to the environment.
- An alternative to waste transfers to land would be to install processing facilities on the Platform, capable of very high temperature incineration of all wastes, including hazardous wastes. This is not practicable from safety, space allocation and cost viewpoints.

Wandoo operations currently collect, segregate and transport waste onshore via licensed waste disposal contractors. The costs associated with this activity are significant, and it is in VOGA's interest to reduce the quantity of waste, and where possible reuse and recycle materials. The waste that is generated by the Wandoo operations is sent to the appropriate state licensed waste disposal facility. This is considered to be the best environmental option for the management of waste.

No further risk reduction measures are considered necessary however ongoing monitoring (through audits and inspections) will be conducted by the VOGA Field Superintendent to ensure the Waste Management Procedures [WPA-7000-YH-0009] is being applied. Application of the procedure will reduce the likelihood of inappropriate disposal of solid and liquid waste and the risk of this hazard is therefore considered ALARP.



6.10 Use and discharge of chemicals for maintenance and inspection activities

6.10.1 Hazard report

Table 6-47: Hazard report – Use and discharge of chemicals for maintenance and inspection activities

HAZARD:	Use and discharge of chemicals for maintenance and inspection activities					
EP risk no.	EP-OP-R15					
Potential impacts:	Reduced water quality. Toxicity effects to marine organisms.					
PREVENTION:						
Activity/cause:	Existing management controls	Control type	Control hierarchy	Performance outcome	Performance standard	Measurement criteria
Use of chemicals for maintenance and inspection activities.	All hazardous liquid chemicals are stored in bunded areas/chemical cradles.	Engineering	Prevention	Minimise environmental impact from a loss of containment of chemicals, by ensuring chemical spills are contained in a bunded area.	Bunds show no visible sign of damage or deterioration that would impair their ability to contain spills.	Visual inspection during operator walk-around.
	Chemical assessment and selection process.	Administrative	Substitution	Minimise impact to the marine environment from planned discharges of chemicals.	Chemicals used in the production process that will be discharged to the marine environment are selected in accordance with the VOGA chemical assessment process.	Chemical changes/new chemical to have approved MoC. Assessment of existing chemicals is outlined in the review of current process chemicals.
	Sulphamic acid neutralisation	Administrative	Prevention		Sulphamic acid used for chemical cleaning is neutralised and tested prior to discharge.	Testing records demonstrate sulphamic acid is neutralised prior to discharge
	Non-routine discharge management	Administrative	Prevention		Non routine discharges with chemical additives are assessed via MOC process to reduce to ALARP prior to discharge in accordance with the Wandoo Platform Operations Manual [VOG-7000-MN-0001].	Management of change records
Pigging, flushing, testing, well intervention discharges (hydro/pressure/leak testing) using biocide.	Routine pigging procedures.	Administrative	Elimination	Minimise impact to the marine environment from planned discharge of pigging/ testing/ flushing liquids and treated water from well interventions. .	PFW will be diverted inboard for at least four hours during biociding to ensure biocide is depleted to baseline levels prior to discharge to sea, in accordance with the Wandoo Platform Operations Manual [VOG-7000-MN-0001].	Records of pigging activity in Pigging Report.
	Biocide treated water management					Biocide treated water is degraded and/or diluted prior to discharge via routing to storage (CGS) or PWTS where feasible, or assessed via MOC process to reduce to ALARP in accordance with the Wandoo Platform Operations Manual [VOG-7000-MN-0001].
MITIGATION:						
Existing management controls	Control type	Control hierarchy	Performance outcome	Performance standard	Measurement criteria	
None identified.	N/A	N/A	N/A	N/A	N/A	
INITIAL RISK WITH EXISTING CONTROLS:						
Consequence	Likelihood (of consequence)			Initial risk		
Incidental (1)	Almost Certain (E)			Medium risk		



ADDITIONAL CONTROLS/DEMONSTRATION OF ALARP - VOGA WORKSHOP:					
A medium risk is defined as tolerable on demonstration of ALARP under the VOGA risk level action criteria. The following ALARP analysis provides assurance that all risk treatment options have been considered.					
Additional management controls		Assessment of option			Adopted/Not adopted
Collection, storage and onshore disposal		All chemically treated water transported to shore for land-based disposal. This would result in an increase in transportation requirements (and increased atmospheric emissions, safety risk and cost). This is also not technically feasible in many instances. Onshore disposal would have environmental impacts that may be greater than those created by offshore disposal, e.g. added energy needed (and associated emissions) for treatment. It is considered grossly disproportionate to any environmental benefit gained.			Not adopted
Eliminate inspection and maintenance activities		The activities that result in chemical treated water discharge are essential for maintaining the integrity of the subsea hydrocarbon system and cannot be avoided. The alternative of doing nothing would potentially compromise the integrity of the system, with increased technical risks and production failures, resulting in significant financial costs and potentially leading to increased risks of loss of containment, resulting in environmental impacts.			Not adopted
RESIDUAL RISK AFTER ADDITIONAL CONTROLS:					
Consequence		Likelihood (of consequence)		Residual risk	
Incidental (1)		Almost Certain (E)		Medium risk	
ACCEPTABLE LEVEL OF RISK DEMONSTRATED:					
Principles of ESD not compromised	External Context – objects or claims considered	Internal Context – VOGA HSE / procedures met	Other Requirements met	RR < High (RRII)	EPO(s) manage risk to acceptable level(s)
Relevant principles of ESD not compromised given proposed controls	N/A – no external objections or claims received	Yes – Impact managed in accordance with VOGA HSE policy and Wandoo Platform Operations Manual [VOG-7000-MN-0001].	Yes – VOGA chemical assessment process aligns with OPSAR, OCNS and IFC guidance.	Yes – RRIII (Medium)	Yes – EPOs specify minimisation of impact. The following relevant overarching EPOs (Section 3.4) maintained providing control measures maintained: EPO-OP-01; EPO-OP-04

6.10.2 Description of hazard

Chemicals are used during maintenance and inspection activities such as pigging, flushing, hydrotesting/pressure testing, leak testing and chemical cleaning.

A summary of the indicative chemicals used for the various maintenance and inspection activities is provided in Table 6-48.

Table 6-48: Chemicals used for inspection and maintenance activities

Activity	Chemical
Hydrotesting/Pressure testing	Biocide
Pigging	
Flushing	Biocide or biocide and corrosion inhibitor
Leak testing	Biocide and Fluorescein dye
Chemical cleaning	Sulphamic acid
Helideck firefighting foam testing	1% AFFF

Biocides are used in conjunction with pigging to enhance biofilm removal by the cleaning pigs and to prevent further microbial activity in the pipework and process fluids. Biocides are also added to seawater used for flushing and testing and as part of well intervention works.

Low concentrations of corrosion inhibitor are also occasionally added to water during flushing activities. Concentrations of corrosion inhibitor discharged following flushing activities are lower than the concentration routinely discharged via the PWTS as part of the production process.

Fluorescein dye is added to water used for leak testing.

Water used for routine pigging containing biocide is diverted to Shaft 4 of the CGS where it degrades over a period of time, after which it is discharged to the ocean in accordance with the Wandoo Platform Operations Manual [VOG-7000-MN-0001].

For other non-routine treated water discharges, the majority of water is directed to storage (the CGS) where it is diluted and degraded to non-toxic levels before being eventually discharged via the ballast water system.

Where discharge into storage is not operationally feasible, treated water is primarily directed to the process and discharged via the PWTS to enable rapid dilution and dispersion to minimise impacts.

During well intervention works, biocide treated water is utilised in wells, risers and BOP to protect the reservoir. Following well intervention works, directing the treated water to storage may not be feasible given the volumes involved and may require to be flowed via the process facilities to be cleaned up and discharged via the PWTS.

Treated water not able to be directed to storage or the PWTS is required to be assessed via MOC process to reduce to ALARP prior to discharge in accordance with the Wandoo Platform Operations Manual [VOG-7000-MN-0001].

Sulphamic acid used for chemical cleaning is neutralised with caustic soda prior to discharge down the hazardous open drainage system. The neutralised water is tested prior to discharge to ensure the pH is 7.

AFFF containing perfluoro octane sulfonate (PFOS) and perfluoro octanoic acid (PFOA) contain Persistent Organic Pollutants (POPs) which are potentially damaging to the receiving environment, as identified by the United Nations Stockholm Convention.

Chemicals are selected using the VOGA chemical selection process (Section 7.11).

Detail on the hazards associated with the storage of chemicals at the Facility is provided in Section 6.20.

Process chemicals are also added to the production process for purposes such as inhibiting scale formation, reducing corrosion (oxygen scavengers, corrosion inhibitor) and preventing growth of bacteria (biocide) in the process. The majority of the production chemicals are ultimately discharged with the treated PFW. This is discussed in Section 6.7.

Any non-routine discharges with chemical additives are assessed via MOC process to reduce to ALARP prior to discharge in accordance with the Wandoo Platform Operations Manual [VOG-7000-MN-0001].

6.10.3 Impact assessment

6.10.3.1 Sensitive receptors

Plankton, infauna, fish (pelagic), marine mammals, marine reptiles and seabirds.

6.10.3.2 Impact assessment criteria

Specific toxicity values for potentially discharged chemicals are used as impact assessment criteria. The concentration of chemical in the discharge is calculated, if this concentration exceeds toxicity values then dilution plots are used to calculate where the conservative toxicity values are achieved in proximity to the platform.

Table 6-49: Toxicity values for chemicals

Chemical	Product toxicity value
Biocide	EC50 0.16mg/L
Fluorescein dye	LC50 337mg/L and LC90 721mg/L
Corrosion inhibitor	LC50 1-10mg/L
Sulphamic acid	LC50 70.3mg/L
1% AFFF	LC50 1300mg/L

6.10.3.3 Impacts

The discharge of chemicals may reduce water quality and could potentially have toxic effects on marine biota.

6.10.3.4 Impact description

Biocide

The biocide THPS (Tetrakis Hydroxymethyl Phosphonium Sulphate) can be harmful to aquatic organisms due to its toxicity levels, however in most instances the chemical has rapid biodegradation to inert THPO (Tris (Hydroxymethyl) Phosphine Oxide) and no bioaccumulation resulting in a minor impact in extent and duration (United States Environmental Protection Agency, 2014). Fluorescein dye

The USA EPA classifies fluorescein as non-toxic and has approved it for use in public drinking water supplies. Fluorescein is biodegradable and photodegradable with decomposition products of carbon dioxide, water and a trace amount of sodium (Farmer and Blew, 2009).

High dosages of fluorescein dye can cause acute and chronic toxic effects on aquatic fauna (24 hour exposure LC_{50} 337mg/L and LC_{90} 721mg/L for *Daphnia pulex* (Walthall and Stark, 1999), however these dosages are at least two orders of magnitude greater than would typically occur during routine operations (1-2mg/L). Investigations of the ecological implications of using fluorescein dye have concluded that impacts are negligible at usage concentrations (Field *et al.*, 1995, as reported in Farmer and Blew 2009; Walthall and Stark, 1999).

Corrosion inhibitor

The impacts of corrosion inhibitor are assessed in Section 6.7.

Sulphamic acid

Sulphamic acid is harmful to aquatic organisms and may cause long term adverse effects in the aquatic environment. High dosages of sulphamic acid can cause acute and toxic effects to marine fauna (96-hour exposure LC_{50} 70.3mg/L for *Pimephales promelas* (Timuraya, 2006)). However, the sulphamic acid is neutralised with caustic soda and discharged to the hazardous drain system. The neutralised sulphamic acid is tested prior to discharge to ensure the pH is 7. The neutralised sulphamic acid consists of water and a low concentration of salt. This would rapidly disperse due to turbulent mixing, and have no toxic impacts on marine organisms when discharged.

AFFF

The helideck AFFF is tested annually. Foam testing with release to the environment during testing, training or maintenance has been suspended and a review of alternative options is being undertaken.

6.10.4 Risk ranking

Chemicals are routinely used in the Wandoo process and discharged at various concentrations into the marine environment. These concentrations are assessed as having a short term and highly localised consequence on the receiving environment and therefore a consequence ranking of '1' (Incidental) and a likelihood of 'E' (Almost certain) was considered appropriate resulting in a Medium risk.

6.10.5 ALARP and acceptability demonstration

6.10.5.1 Overview

The risk associated with discharge of chemicals as listed, can be managed through the implementation of effective control measures and associated performance monitoring. The ALARP assessment has concluded that the risks are being managed to ALARP because:

- There are sufficient layers of protection in place for the current risk level; and
- Additional controls and alternative arrangements were not considered to be practical due to the associated increase to other risks.

6.10.5.2 Existing controls

General controls to reduce the environmental impact of the use of chemicals for maintenance and inspection activities include:

- Chemicals stored in chemical cradles, or bunded area; and
- Chemical assessment process as outlined in 7.11.

The controls implemented for these chemical discharges are appropriate to the relevant chemical:

- Biocide treated water is degraded and/or diluted prior to discharge via routing to storage (CGS), or if not feasible via PWTS. Treated water not able to be directed to storage or the PWTS is required to be assessed via MOC process to reduce to ALARP prior to discharge in accordance with the Wandoo Platform Operations Manual [VOG-7000-MN-0001].
- Sulphamic acid is neutralised prior to discharge;
- Fluorescein dye is discharged directly due to the non-toxic nature;
- Non routine chemical discharges are required to be assessed via MOC process to reduce to ALARP prior to discharge in accordance with the Wandoo Platform Operations Manual [VOG-7000-MN-0001].

6.10.5.3 Additional controls and alternative arrangements

VOGA carried out an assessment of alternative arrangements and additional controls to reduce risks. Based on the current management of the risks no additional controls were identified, as the fluorescein dye has low impact and the sulphamic acid is neutralised.

6.10.5.4 Conclusion

Many of the chemicals described in this section are critical to maintaining the integrity of the Facility and are risk controls for loss of containment events. These are:

- Managing corrosion (corrosion inhibitor);
- Preventing process leaks (hydrotesting and pressure testing using biocide treated water); and
- Diagnosing process leaks (leak testing with biocide treated water and/or fluorescein dye).

By reducing the amount of chemical use to ALARP and the implementation of the controls described above, the risk is considered acceptable and ALARP.



6.11 Noise

6.11.1 Hazard report

Table 6-50: Hazard report – Noise

HAZARD:	Noise							
EP risk no.	EP-OP-R07							
Potential impacts:	Injury to hearing or other organs of marine fauna. Masking or interfering with biologically important sounds. Disturbance leading to behavioural changes or displacement of fauna.							
PREVENTION:								
Activity/cause:	Existing management controls	Control type	Control hierarchy	Performance outcome	Performance standard	Measurement criteria		
Operation of cooling water (and fire water pumps)	No management measures identified	N/A	N/A	N/A	N/A	N/A		
Vessel operation.	The interaction of vessels with cetaceans within the Wandoo Field will be consistent with the EPBC Regulations (2000) where practicable.	Administrative	Reduction	Minimise noise impacts on marine fauna by reducing interactions with vessels.	The interaction of vessels with cetaceans within Wandoo Field will be consistent with the EPBC Regulations (2000) where practicable, as identified in VOGA Marine Operations Manual [WNB-1000-YV-0001].	Cetacean interactions and vessel response incidents reported to VOGA.		
Helicopter operation.	No management measures identified	N/A	N/A				N/A	N/A
Geophysical and hydrographic surveys such as: side scan sonar, sub-bottom profiling; multi beam and single beam echo sounder surveys.	For geophysical and hydrographic surveys, the interaction of vessels with cetaceans within the Wandoo Field will be consistent with the EPBC Regulations (2000) where practicable.	Administrative	Reduction				Survey contractor procedures are to specify response required on cetacean interactions	Cetacean incidents reported to VOGA.
MITIGATION:								
Existing management controls	Control type	Control hierarchy	Performance outcome	Performance standard	Measurement criteria			
None identified.	N/A	N/A	N/A	N/A	N/A			
INITIAL RISK WITH EXISTING CONTROLS:								
Consequence	Likelihood (of consequence)		Initial risk					
Incidental (1)	Almost Certain (E)		Medium risk					
ADDITIONAL CONTROLS/DEMONSTRATION OF ALARP - VOGA WORKSHOP:								
A medium risk is defined as tolerable on demonstration of ALARP under the VOGA risk level action criteria. The following ALARP analysis provides assurance that all risk treatment options have been considered.								
Additional management controls	Assessment of option				Adopted/Not adopted			
Dedicated Marine Fauna Observer on vessels.	Improved ability to spot and identify marine fauna at risk of impact from vessel noise (that may cause harm). Additional cost of contracting specialist Marine Fauna Observers while the risk to all EPBC Act-listed marine fauna cannot be reduced due to unpredictable presence of some species. Vessel masters are keeping watch for potential hazards. Cost disproportionate to increase in environmental benefit.				Not adopted.			
Eliminate use of support vessels	May reduce the amount of noise emissions from vessels, although acoustic disturbances to marine fauna due to vessel activities are expected to be negligible as the number of vessel activities required are minimal. Elimination of support vessels from the field would not achieve VOGA legal requirements for petroleum production or its work-plan objectives for oil and gas production and may compromise safety standards for other marine users.				Not adopted			



ADDITIONAL CONTROLS/DEMONSTRATION OF ALARP - VOGA WORKSHOP:

RESIDUAL RISK AFTER ADDITIONAL CONTROLS:

Consequence	Likelihood (of consequence)	Residual risk
Incidental (1)	Almost Certain (E)	Medium risk

ACCEPTABLE LEVEL OF RISK DEMONSTRATED:

Principles of ESD not compromised	External Context – objects or claims considered	Internal Context – VOGA HSE / procedures met	Other Requirements met	RR < High (RRII)	EPO(s) manage risk to acceptable level(s)
Relevant principles of ESD not compromised given proposed controls	N/A – no external objections or claims received	Yes – potential impact managed in accordance with VOGA HSE policy and Marine Operations Manual [WNB-1000-YV-0001].	Yes – EPBC Regulations (2000)	Yes – RRIV (Low)	Yes – EPOs specify minimise noise impacts on marine fauna by reducing interactions with vessels. The following relevant overarching EPOs (Section 3.4) maintained providing control measures maintained: EPO-OP-01; EPO-OP-04; EPO-OP-05; EPO-OP-06; EPO-OP-07; EPO-OP-08; EPO-OP-09; EPO-OP-10; EPO-OP-11; EPO-OP-12; EPO-OP-13

6.11.2 Description of hazard

The following activities associated with Wandoo operations, generate noise:

- Vessel and helicopter operations;
- Operation of cooling water and firewater pumps;
- Geophysical surveys:
 - side-scan sonar; and
 - sub-bottom profiling surveys (using pingers, boomers, chirps and sparkers).

6.11.2.1 Vessel and helicopter operations

Offtake tanker movements will be at three-to-five week intervals. Movements of support vessels will be approximately twice a week.

Sources of noise from offtake tankers and support vessels include propeller cavitation, hydrodynamic flow around the hull and operation of machinery and equipment.

Noise levels depend on the size of the vessel/tanker and the speed at which it is travelling. Under normal conditions (i.e. when vessels are idling or moving between sites), source levels would be between 160-180dB re 1 μ Pa at 1m. Highest noise levels are likely to occur during berthing of offtake tankers where vessels will use bow thrusters to move into and maintain position. McCauley (1998) measured underwater broadband noise equivalent to approximately 182dB re 1 μ Pa at 1m from a vessel holding station.

There will be approximately five helicopter movements per week during normal operations. The main acoustic source associated with helicopters is the impulsive noise from the main rotor and high-speed impulsive noise related to trans-sonic effects on the advancing blade. Dominant tones in noise spectra from helicopters and fixed wing aircraft are generally below 500Hz (McCauley, 1994). Other tones associated with the main and tail rotors and other engine noise can result in a larger number of tones at various frequencies.

6.11.2.2 Operation of cooling water and firewater pumps

Cooling water pumps run continuously, however as the motor is mounted topside, the underwater noise attributable to these pumps is negligible. The firewater pumps are likely to produce slightly more underwater noise; however, the firewater pumps are only run for fighting fires (which is a safety critical function) or testing purposes (which is short duration).

6.11.2.3 Geophysical and hydrographic surveys

Geophysical and hydrographic surveys use sound to make measurements of the seabed and sub-seabed. Sounds produced are of high energy and frequency. Side-scan sonar is a geophysical technique that is used to produce an image of the sea floor. Sub-bottom profiling is used to establish the geology of the seabed. Low-frequency systems such as boomers and sparkers provide information to greater depths. High-frequency systems such as chirps and pingers give more details at shallower depths.

Multi-beam and single-beam echo sounders are used to determine water depths and can also be used to assess seabed composition.

These activities are described in Sections 2.8.2 and 2.8.3 and will occur relatively infrequently based on their requirement for use pre drilling. Geophysical and hydrographic surveys are unlikely to occur more often than once per year.

Propagation of underwater noise is dependent on a number of environmental factors including temperature, water depth, composition of sea floor, frequency of source sound etc.

6.11.3 Impact assessment

6.11.3.1 Sensitive receptors

Pelagic (fish), marine mammals, marine reptiles and seabirds.

6.11.3.2 Impact assessment criteria

The impact assessment criteria for marine species is based on species specific threshold sensitivity to underwater noise and the levels required to cause behavioural or pathological damage. These are detailed within Section 6.11.3.4.

6.11.3.3 Impacts

Noise and vibration in the underwater environment has the potential to impact marine fauna, and can result in a range of responses including (Richardson *et al.*, 1995; Southall *et al.*, 2007):

- Injury to hearing or other organs. Hearing loss may be temporary (temporary threshold shift) or permanent (permanent threshold shift);
- Masking or interfering with other biologically important sounds (including vocal communication, echolocation, signals and sounds produced by predators or prey); and
- Disturbance leading to behavioural changes or displacement of fauna.

6.11.3.4 Impact description

The highest sound emission levels will be from the hydrographic and geophysical surveys. Typical sound intensities and frequencies produced from geophysical and hydrographic surveys are presented in Table 6-51 below. Sound frequencies and peak sound levels produced are in the range of 0.5 to 500kHz and of 202-245dB re 1µPa at 1m from the array respectively. Sounds increase in wavelength with distance from the source experiencing rapid loss at higher frequencies (Swan *et al.*, 1994).

Modelling has previously been undertaken to determine the sound levels at increasing horizontal distance away from the source array for two geophysical sparker sound sources; Applied Acoustics Squid 500 and Squid 200. The sound exposure levels were predicted for four different combinations of water depth and spark type. The peak sound level for the Squid 2000 and the Squid 500 were 222dB re 1µPa peak and 216dB re 1µPa respectively at 1m from the array. In all four cases modelled, the received sound exposure levels are predicted to have dropped below 160dB re 1µPa² within 20m of the source for the Squid 500 and within 40m of the source for the Squid 2000 (Duncan and Salgado-Kent, 2011). Any impact of sound and vibrations from similar survey equipment used during operations is expected to quickly attenuate through the water column.

As the chirps, boomers and echo sounders generate sound pulses within the frequency range of the sparker 0-300kHz, it is expected sound levels generated by these surveys will decrease from the source array at a similar level. The side-scan sonar generates sound pulses of a higher frequency hence the sound level from the side-scan sonar is expected to decrease more rapidly with increasing distance from the source array.

Under normal operating conditions when a vessel is idling or moving around the field, the vessel noise would be detectable only over a short distance. Noise from support vessels, would be at its maximum level, when there is a support vessel using main engines and bow thrusters to keep an export tanker on the CALM Buoy. The noise from a vessel holding its position using bow thrusters and strong thrust from its main engines (relatively small proportion of time) may be detectable above background noise levels during calm weather conditions, for 20km or more from the vessel although this range of audibility will be reduced under noisier (windier) background conditions (BHP Billiton, 2005).

The main acoustic source associated with helicopters is the impulsive noise from the main rotor and high-speed impulsive noise related to trans-sonic effects on the advancing blade. Dominant tones in noise spectra from helicopters and fixed wing aircraft are generally below 500Hz (McCauley, 1994). Other tones associated with the main and tail rotors and other engine noise can result in a larger number of tones at various frequencies (BHP Billiton, 2005).

Noise from platform operations is expected to be low as all operating equipment including generators, engines and machinery is above sea level. The frequency and level of noise received under water from topside operations will depend on a number of variables including the type of infrastructure; the types and sizes of engines; as well as the local hydro-acoustic and geo-acoustic environment.

Table 6-51: Typical frequency and sound ranges from equipment expected to be used for operations

Source	Frequency (KHz)	Sound (dB re 1µPa at 1m)
Side-scan sonar	100-500	220-226
Sub-bottom profiling (Chirps system)	3-40	202-208
Sub-bottom profiling (Boomers)	0.5 -5	204-227
Sub-bottom profiling (Sarker) (e.g. Squid 500 and Squid 2000)	0-300	216-222
Multi-beam echosounders	10.5-200	225-245
Single-beam echo sounders	10-200	210-230
Vessel operations	0.005-1.2	182

6.11.3.5 Marine mammals

Marine mammals are sensitive to noise in the marine environment. Their use of sound for communication, prey capture, predator avoidance, navigation and their physiological features (i.e. large gas-filled organs) make them vulnerable to both disturbance and physiological damage from underwater noise of sufficient magnitude.

Odontocetes or toothed cetaceans (sperm whale, beaked whales and dolphins) produce echo clicks that have the highest sound levels of any recorded marine mammal ranging from 220-230dB at 1µPa at 1m at frequencies between 10 and 100kHz (DoIR, 2007). This is of a similar

frequency to that of the hydrographic surveys. However behavioural responses have not been observed in odontocetes unless received levels exceeded 186dB re 1 μ (USN, 1999), which is not expected beyond 40m from the source (Duncan and Salgado-Kent, 2011).

Baleen whales (e.g. blue and humpback whales) communicate using low-frequency signals (12Hz to 8kHz but predominantly less than 1kHz) (McCauley, 1994). Their low-frequency hearing capability is above the energy output range generated by geophysical and hydrographic surveys. Therefore, no significant impacts to baleen whales are expected.

The humpback whale is the most commonly sighted whale in the region, with northerly migrations potentially through the Project area between April and August (peaking in July) and southerly migrations between August and October (peaking mid-August to mid-September). Behavioural responses to underwater noise included 'stand-off' behaviour for migrating humpback whales at received sound levels of 157 to 164dB re 1 μ Pa. Resting pods exhibit 'stand-off' behaviour at received sound levels of 143dB re 1 μ Pa and avoidance at 140dB re 1 μ Pa (McCauley *et al.*, 2000). These noise levels would be expected to occur within approximately 40m for migrating whales and 480m for resting pods from a typical geophysical survey.

Dugongs exhibit greatest sensitivity to sounds in the 1kHz to 2kHz range, which is within the range of energy output of the geophysical and hydrographic surveys (DoIR, 2007). Dugongs generally calve in shallow tropical waters (<1m deep), between August and September, although may calve as late as December (DoIR, 2007). Dugongs are migratory and are known to occur around the islands of the NWS, Shark Bay, Exmouth Gulf and the Dampier Archipelago where seagrass beds occur (Gales *et al.*, 2004). There is a low likelihood of encountering dugongs during operational activities as the nearest potential dugong habitat is the Dampier Archipelago that is located 40km from the Operational Area.

No known aggregation, resting, breeding or feeding areas for marine mammals lies in close proximity to the Operational Area (Section 4). Therefore, the risk of acoustic disturbance to cetaceans is expected to be minimal as it is expected that they would need to be within 40m of the noise source in order to exhibit a behavioural response.

Stationary sources of offshore noise, such as that associated with the operation of the platform, being cooling water and firewater pumps, appears less disruptive to cetaceans than moving sources, such as ships (NMFS, 2001). However, severe sound emissions from offshore developments have the potential to induce stress and may cause abandonment of sensitive habitats (none of which are in the vicinity of the Operational Area), such as calving and nursery sites (McCauley, 1994). Given the noise sources associated with operational activities, the impact of platform noise is expected to be minimal.

6.11.3.6 Turtles

Electro-physical studies have indicated that marine turtle hearing is most sensitive to sounds between 100Hz to 700Hz (McCauley, 1994), which is below the range generated by hydrographic and geophysical surveys. No absolute thresholds are known for the sensitivity to underwater noise or the levels required causing pathological damage. Studies indicate that turtles may begin to show behavioural responses to an approaching seismic array at received sound levels of approximately 166dB re 1 μ Pa, and avoidance at around 175dB re 1 μ Pa (McCauley *et al.*, 2000); these sound levels are expected to occur between 20m and 40m from the source array based on geophysical sparker modelling outlined above. As such, impacts on turtle species are expected to be minimal.

It is not expected that behavioural responses from turtles would be initiated more than 5km of a nesting beach and as the nearest turtle nesting beaches are located at the Dampier Archipelago 40km away, there is not expected to be any impact on turtle hatchlings.

6.11.3.7 Sharks

Previous studies indicate that sharks are sensitive to low frequency sounds in the 10Hz to 800Hz range and insensitive to frequencies above 1kHz (Myrberg, 1996). The risk of acoustic disturbance to sharks will be low as the sounds generated by surveys range from 0.5kHz to 500kHz.

Also, given their generally wide-ranging habitat and known avoidance response to sound, shark species, including whale sharks, are not expected to exhibit significant negative behavioural or physical impacts from operational activities.

6.11.3.8 Fish

A considerable body of literature exists on the behavioural response of fish to vessel noise (Olsen, 1990). These studies have shown that fish avoid approaching vessels to some degree, usually by swimming down or horizontally away from the vessel path (BHP Billiton, 2005). The degree of observed effect weakens with depth and the effect is temporary with normal schooling patterns resuming shortly after the noise source has passed. Surface and mid-water dwelling fishes may theoretically be adversely affected by noise generated during vessel movements and normal production operations.

It has been observed that acoustic noise can lead to behavioural responses in fish; however, the nature and extent of the response varies and depends on a range of parameters including the species involved, propagation and aspect of the array. McCauley (1994) applying the behavioural observations of benthic fish to noise by Pearson *et al.* (1992), indicated sound levels at which behavioural changes in fish would be observed. These included:

- A startled response (at ~200 to 205dB re 1 μ Pa) will occur directly beneath the array. At this point most fish flee the sound of the array (i.e. sudden flexions of the body followed by rapid swimming or a series of shudders);
- An alarm response (at ~180dB re 1 μ Pa) will occur. Based on the modelling results this sound level would occur within 40m of the array; and
- A subtle behavioural response (at ~160dB re 1 μ Pa) will occur. Based on the modelling results this sound level would occur within 40m of the array.

6.11.3.9 Birds

Birds generally hear at a narrower frequency range than mammals, with best hearing at frequencies between 1kHz and 5kHz (Dooling and Popper, 2007). However, there is little information available specific to seabird and shorebird hearing and thresholds for disturbance.

6.11.3.10 Invertebrates

Crustaceans such as crabs, prawns, scampi and lobster do not possess gas-filled cavities and hence have a reduced risk of acoustic disturbance compared with marine mammals, reptiles and fish with air bladders (Parry and Gason, 2006). Webb and Kempf (1998) exposed brown shrimp to sound source levels of 190dB re 1 μ Pa at 1m depth via a 15-gun array and no evidence of mortality or reduced catch rates for the shrimp was found.

ROV surveys of the NWS similar to the Operational Area have indicated that benthic communities are generally sparse with low densities of organisms (e.g. crustaceans, molluscs and polychaetes).

6.11.4 Risk ranking

Helicopters and vessels frequently visit WNA and WNB throughout the year for short durations, with potential impacts negligible. Cooling water pumps are operational year-round however underwater noise attributable to these pumps is negligible. The likelihood is therefore considered 'E' (Almost certain). The consequence is considered to be a '1' (Incidental) which is higher than expected however is the lowest possible consequence on the VOGA risk matrix. This results in a risk ranking of Medium.

Geophysical and hydrographic surveys are unlikely to occur more often than once per year within the Permit Area. Therefore, a consequence ranking of '1' and a likelihood of 'D' for a Medium risk was considered appropriate.

6.11.5 ALARP and acceptability demonstration

Helicopters are the only practical option for personnel transfers to and from the facility. The alternative would be vessel transfers, however, the use of vessels for crew changes is deemed to be a high safety risk, particularly in inclement weather conditions and through the use of hoisted baskets for personnel transfer. IMCA Guidance on the Transfer of Personnel to and from Offshore Vessels (IMCA, 2010) states: "All basket transfers should be considered a high risk operation at all times and they should be undertaken when transfer is essential and cannot be undertaken by other means. It would not be appropriate to use personnel baskets for routine crew changes in open waters when more appropriate methods of transfer are available."

Elimination of supply vessel is not feasible. There is a requirement to supply the Platform with a range of provisions and operation is intermittent.

The possibility to suspend operations when sensitive species are sighted near the Facility is impractical from a logistical and cost viewpoint, in light of the temporary and minor nature of the impacts.

Cooling water pumps and firewater pumps are used to meet safety critical and/or operational critical requirements for the facility. No suitable alternatives are available.

Impact to the environment caused by this hazard is assessed by VOGA to be acceptable due to the relatively small impact area and the fact that alternative arrangements may result in a larger environmental and safety impact.

Sounds produced by vessel and helicopter operations and use of topside pumps are not expected to be significant as they are of short duration and unlikely to impact on marine fauna that may be present in the vicinity of the platform at the time of operations. Similarly, geophysical surveys are undertaken on an infrequent basis (less than annual basis) and any risks associated with noise will be transient and temporary. The risks from these activities are therefore considered acceptable and ALARP.



6.12 Atmospheric emissions

6.12.1 Hazard report

Table 6-52: Hazard report – Atmospheric emissions

HAZARD:	Atmospheric emissions					
EP risk no.:	EP-OP-R08					
Potential impacts:	A localised reduction in air quality due to contribution to global greenhouse gases. A localised reduction in air quality due to particulate matter from diesel combustion.					
PREVENTION:						
Activity/cause:	Existing management controls	Control type	Control hierarchy	Performance outcome	Performance standard	Measurement criteria
Flaring during normal operations.	Flaring volumes are monitored daily to ensure that any increase in flaring is identified and can be addressed in a timely manner.	Administrative	Reduction	Minimise atmospheric emissions associated with flaring, blowdown and venting.	Flaring volumes are recorded daily to ensure that any significant increase in flaring is identified and source of increase is noted.	Flaring volumes are recorded daily in the Wandoo daily report.
					Atmospheric emissions from flaring shall be reviewed annually.	Emissions reports, e.g. NGERS and NPI.
Flaring during blowdown.	No controls identified. Blowdown is a requirement for MAE prevention. Volumes are recorded as per flared gas (above).	N/A	N/A		N/A	N/A
Venting via flare (flame out scenario).	Continuous pilot system with loss of pilot flame alarms.	Administrative	Reduction		Pilot system preventative maintenance to ensure that flare system is functional	Maintenance records
Venting of LP process vessels/ systems.	No controls identified. Venting of LP vessels, tanks and shafts is predominantly inert gas and is a requirement to prevent unsafe environment developing within.	N/A	N/A		N/A	N/A
Venting of tanker cargo tanks.	No controls identified. Venting of tankers cargo tanks is predominantly inert gas from the tankers boilers and is a safety requirement to prevent tank explosions.	N/A	N/A	N/A	N/A	N/A
Operation of WNA chemical pump and instrument gas system, both of which result in process gas emissions during use.	No controls identified.	N/A	N/A	N/A	N/A	N/A



Activity/cause:	Existing management controls	Control type	Control hierarchy	Performance outcome	Performance standard	Measurement criteria
Vessels operations (offtake tankers' emissions excluded from scope of EP).	Vessels will comply with Marine Orders – Part 97: Marine Pollution Prevention – Air Pollution (appropriate to vessel class) for emissions from combustion of fuel.	Engineering	Substitution	Minimise atmospheric emissions associated with vessel and helicopter operations.	Vessels comply with Marine Orders – Part 97: Marine Pollution Prevention – Air Pollution, the POTS Act, the Navigation Act 2012 and Annex VI of MARPOL 73/78 (as applicable to vessel and engine size, type, class), specifically: <ul style="list-style-type: none"> marine diesel engines meet NOX emission requirements and limits as set out by MARPOL 73/78, Annex VI, Regulation 13, and have an International Air Pollution Prevention (IAPP) certificate. onboard incinerators (if present) will meet International Maritime Organization (IMO) standards and are identified in the vessels' IAPP certificate. equipment and systems that contain ozone depleting substances (ODS) comply with MARPOL 73/78, Annex VI, Regulation 12, are identified in the vessels' IAPP certificate and an ODS record book is maintained (where applicable). vessels >400 GT have a Ship Energy Efficiency Management Plan (SEEMP). MODU/vessel contractors use marine diesel with 0.5% m/m sulfur content (on and after 1 January 2020) as required by the Protection of the Sea (Prevention of Pollution from Ships) Act 1983. 	IAPP certificate ODS Record Book Records of Ship Energy Efficiency Management Plan (SEEMP). Records of low sulfur fuel usage
Helicopter operations.	No controls identified. Fuel specification is as per helicopter engine specification, and fuel usage is as per flight plan and operational requirements.	N/A	N/A		N/A	N/A
Power generation and gas lift compressor.	Emissions associated with power generation are eliminated on WNA and CALM Buoy by utilising renewable energy.	N/A	N/A	Minimise atmospheric emissions associated with power generation and gas lift compressor operations on Wandoo Facilities.	N/A	N/A
	Fuel gas is used in preference to diesel for power generation when reservoir conditions permit.	Engineering	Substitution		Maximise gas use without impacting reservoir by fuel forecasting plan which includes reservoir management.	Records of fuel type usage is kept and reviewed against target.
	Power generator and gas lift compressor maintained to optimise efficiency.	Engineering	Reduction		Maintenance of power generator/gas lift compressor in accordance with planned maintenance for turbine generator.	Maintenance records.
				Atmospheric emissions from power generation and gas lift compressor operation are reviewed annually.	Emissions report, e.g. NGERS and NPI.	
Use of refrigerants (in HVAC systems).	Refrigeration system subject to regular maintenance.	Engineering	Reduction	Minimise emissions of refrigerant by maintenance of equipment.	Maintenance of refrigeration systems in accordance with maintenance procedures for HVAC and refrigeration system.	Maintenance records.
Diesel powered equipment on WNA and WNB	Low sulphur diesel is used for diesel powered equipment on WNA and WNB.	Engineering	Substitution	Minimise atmospheric emissions associated with diesel powered equipment.	Fuel purchased in Australia shall meet Australian standards.	Fuel purchased through an approved vendor.



MITIGATION:					
Existing management controls	Control type	Control hierarchy	Performance outcome	Performance standard	Measurement criteria
None identified.	N/A	N/A	N/A	N/A	N/A
INITIAL RISK WITH EXISTING CONTROLS:					
Consequence	Likelihood (of consequence)		Initial risk		
Incidental (1)	Almost Certain (E)		Medium risk		
ADDITIONAL CONTROLS/DEMONSTRATION OF ALARP - VOGA WORKSHOP:					
A medium risk is defined as tolerable on demonstration of ALARP under the VOGA risk level action criteria. The following ALARP analysis provides assurance that all risk treatment options have been considered.					
Additional management controls	Assessment of option			Adopted/Not adopted	
No use of diesel on facility, use of fuel gas only	Emissions associated with turbines and diesel combustion engines are associated with critical functions which could not be eliminated. Routine maintenance on turbines and replacement based on service life which will maintain the efficiency of the turbines. Alternative fuels which produce lower emissions, i.e. natural gas, is only feasible for the turbines and is only used in preference to diesel if reservoir conditions permit.			Not adopted	
No flaring	Flaring is required for safe operations. During normal operation, the operating philosophy of the flare is to minimise flare gas and to operate with the pilot light burning (which is a critical safety function), i.e. flare load is intermittent based on operations and maintenance activities.			Not adopted	
RESIDUAL RISK AFTER ADDITIONAL CONTROLS:					
Consequence	Likelihood (of consequence)		Residual risk		
Incidental (1)	Almost Certain (E)		Medium risk		
ACCEPTABLE LEVEL OF RISK DEMONSTRATED:					
Principles of ESD not compromised	External Context – objects or claims considered	Internal Context – VOGA HSE / procedures met	Other Requirements met	RR < High (RRII)	EPO(s) manage risk to acceptable level(s)
Relevant principles of ESD not compromised given proposed controls	N/A – no external objections or claims received	Yes – Impact managed in accordance with VOGA HSE policy, PMS and emissions reporting process.	Yes – MARPOL 73/78, NGERs	Yes – RRIII (Medium)	Yes – EPOs specify minimising atmospheric emissions. The following relevant overarching EPOs (Section 3.4) maintained providing control measures maintained: EPO-OP-01; EPO-OP-05; EPO-OP-06; EPO-OP-07; EPO-OP-08; EPO-OP-09; EPO-OP-10; EPO-OP-11; EPO-OP-17

6.12.2 Description of hazard

6.12.2.1 Emissions Overview

Atmospheric emissions will occur during the normal operation of the Wandoo Facility due to our planned activities/operations, including:

- Flaring, blowdown and venting;
- Venting of tanker cargo tanks;
- Operation of WNA chemical pump (pneumatic) and instrument gas system, both of which result in minor methane gas emissions;
- Vessels (excluding tanker) and helicopter operations;
- Power generation and gas lift compressor;
- Use of refrigerants (in HVAC systems); and
- Diesel-powered equipment on WNA and WNB (non-turbine equipment, e.g. crane, firewater pumps, emergency diesel generator and portable equipment).

Vermilion account and report greenhouse emissions as part of the annual National Greenhouse and Energy Reporting obligations which requires reporting of scope 1 and 2 emissions. Scope 1 and 2 greenhouse gas emissions during 2018/19 and 2019/20 Wandoo operations is approximately 70,000tCO₂-e; which under Australian Government policy in 2020 is under the safeguard threshold of 100,000tCO₂-e. In 2018/19 Wandoo represented approximately 0.01% of Australia's emissions (source 'Quarterly Update of Australia's National Greenhouse Gas Inventory: June 2019, Commonwealth of Australia 2019).

A breakdown of greenhouse emission by source is provide in Table 6-53. The emissions total is influenced by power consumption, associated with power and compression, and water throughput which results in methane being vented. Power consumption is can vary based on rotating electrical equipment uptime (e.g. availability of electrical pumps such as ESPs), speed and efficiency.

Table 6-53 Wandoo greenhouse gas scope 1 and 2 emissions by source (based on 2018/19 and 2019/20 reporting periods)

Emissions source	Proportion of scope 1 and 2 emissions
Power and compression	65.1%
Flaring	4.7%
Low pressure process vents	29.8%
Oil storage venting	negligible
Gas processing	0.4%

Table 6-54 considers the facility changes proposed the EP and the impact on overall emissions.

Table 6-54 Impact of proposed permanent changes on greenhouse gas emissions

Change	Impact on emissions	Impact on emissions intensity
Additional three wells on Wandoo	As compression capacity is not being changed, introduction of new wells will have a marginal impact.	Typically, oil and gas facilities have an emissions intensity profile that increases over time as energy consumption is relatively constant whilst production is declining. Introduction of additional production helps offset the decline and improves the projected emissions intensity.
Increase capacity of produced water treatment and discharge to 36kL/d	Additional produced water can result in increase the amount of Methane and CO ₂ that evolves in the process. However, with introduction of ISFU-2 being connected to the flare system and bypass of CFUs in December 2020, increased produced water will not result increase in vented emissions. Flaring quantities would increase by 5-10% as a result of this change resulting in an emission increase of less than 0.5%.	Typically, oil and gas facilities have an emissions intensity profile that increases over time as energy consumption is relatively constant whilst production is declining. Introduction of additional water capacity helps offset the production decline, by adding approximately 10% extra forecast production. With emission increasing by 0.5% and production increasing by 10% post the change the facility will improve emissions intensity.

6.12.2.2 Power generation and gas lift compressor

Power generation and compression systems are described in 2.6.7 and account for 65.1% of Wandoo’s greenhouse gas emissions (see Table 6-53).

The Wandoo power generators and Gas Lift Compressor (GLC) can use either fuel gas or diesel.

Fuel selection is based on reservoir management needs. Whilst from a cost and emissions point of view, Vermilion prefer to use fuel gas over diesel, the gas cap is a limited resource and needs to be managed to maintain reservoir conditions and optimise the long-term recovery of oil from the Wandoo field. Fuel allocation, consumption rates and management are based on reservoir outlook and diesel/gas budgeting process. Excess consumption of either fuel is unlikely to be sustained as it risks future production or adds daily operational costs.

Power generation and GLC systems at the Facility therefore contribute to the emission of combustion by-products such as NO_x, SO_x and particulate matter.

6.12.2.3 Flaring and blowdown

The flaring and blowdown are described in Section 2.5.8.

Process flaring (including blowdown events) account for 4.7% of Wandoo's greenhouse gas emissions (see Table 6-53). Like fuel gas (reservoir gas cap management), the operating philosophy is to limit flaring to the minimum quantities required to sustain the flare pilot.

Low-pressure gas from the Second Stage Separator is compressed in the Recovered Gas Compressor then routed to the Lift Gas Compressor suction. The recovery of low-pressure gas minimises the flaring of hydrocarbon gas from the facility. Daily flaring rates may increase when the recovered gas is out of service or offline whilst it is being maintained.

The relief and blowdown discharges are routed via header lines to Flare Knockout Vessel sized to remove any entrained liquids from the gas. Gas is routed to the flare tip supported on an angled boom. This gas is normally combusted via flaring although the location of the flare tip is suitable for both flaring and cold venting.

Flared gas is comprised mainly of methane (CH₄) and inert nitrogen gas (N₂) used for sweeping/purging the flare headers and as flotation gas within the parts of produced water treatment system. Primary combustion by-products are carbon dioxide (CO₂), carbon particulates and water. It also contains trace amounts of hydrocarbons, carbon monoxide (CO), oxides of nitrogen (NO_x) and oxides of sulphide (SO_x).

6.12.2.4 Low pressure venting and cold venting

Low pressure vent systems are described in Section 2.5.8.2 and contribute approximately 30% of Wandoo's greenhouse emissions. The low-pressure vent system is unable to be connected to the flare system due to process safety hazards associated with integration of potentially pressurised flammable gas systems with low pressure atmospheric tank systems.

Cold venting from the flare is rare and generally avoided via flare pilot monitoring and maintenance. Cold venting from flare should only occur if the flare pilots are malfunctioning and are not lit.

On WNB water vapour, methane, nitrogen blanket gas and CO₂ are vented to atmosphere from LP vents located halfway up the flare boom. Nitrogen blanket gas is added upstream to purge/sweep lines and headers to prevent build-up of flammable or corrosive gas within dead legs and to ensure that oxygen is excluded for process safety reasons. Nitrogen gas is also used as flotation gas in parts of the produced water treatment system that connect to the LP vent. It is possible but unlikely that H₂S could be present in the LP Vent. H₂S has been operationally encountered occasionally at low concentrations but only from the shaft 4 forced ventilation discharge. Venting of oil storage and tanker cargo tanks

The cargo tanks of the tanker are already filled with inert gas (typically boiler flue gas) prior to arrival in the field. As the tanker takes on oil, the inert gas is vented to atmosphere. It is a requirement to have inert gas in the tanks to prevent cargo tank explosions.

6.12.2.5 Vessel operations, helicopter operations and use of diesel-powered equipment

The use of fuel to power vessel and helicopter engines, and mobile and fixed plant (e.g. cranes, generators) will result in gaseous emissions of Global Greenhouse Gas (GHG) such as carbon dioxide (CO₂), methane (CH₄) and nitrous oxide (N₂O), along with non-GHG particulate emissions such as sulphur oxides (SO_x) and nitrous oxides (NO_x). Section 6.11.2 describes the frequency of vessel and helicopter operations.

6.12.2.6 Refrigeration systems

Refrigeration systems at the facility include refrigerators and HVAC systems. The refrigerants used are ozone depleting substances (ODS) and as such are recovered and reused whenever possible.

6.12.2.7 Marine Orders Part 97

Marine Orders Part 97 – Marine pollution prevention – air pollution implements Part IIID of the POTS Act, Chapter 4 of the Navigation Act 2012, and Annex VI of MARPOL 73/78 (air pollution).

Support vessels ≥ 400 GT are required to have International Air Pollution Prevention (IAPP) certificates and Engine International Air Pollution Prevention (EIAPP) certificates to demonstrate that the vessel or facility and onboard marine diesel engines comply with the requirements of Annex VI of MARPOL 73/78.

Low-sulphur fuel oil / marine diesel with 0.5% mass-for-mass (m/m) sulphur content is required to be used in engines after 31 December 2019.

In accordance with Annex VI of MARPOL 73/78, the requirements do not apply to the following and therefore do not apply to emissions from the Wandoo facility operations:

- emissions resulting from the incineration of substances that are solely and directly the result of the exploitation and offshore processing of seabed mineral resources (i.e. hydrocarbons), including but not limited to flaring during well completion and testing operations and flaring arising from upset conditions
- emissions associated solely and directly with the treatment, handling, or storage of seabed minerals (i.e. hydrocarbons)
- emissions from marine diesel engines that are solely dedicated to the exploration, exploitation and associated offshore processing of seabed mineral resources (i.e. hydrocarbons)

6.12.3 Impact assessment

6.12.3.1 Sensitive receptors

Seabirds and human receptors (other users).

6.12.3.2 Impact assessment criteria

Impact assessment is based on alignment with Company and societal values. That is, alignment with the VOGA HSE policy and perceptions of the society at large.

6.12.3.3 Impacts

The known and potential environmental impacts of atmospheric emissions are:

- Localised and temporary decrease in air quality; and
- Contribution to GHGs.

6.12.3.4 Impact description

Release of GHG and non-GHGs

In 2018/19 Wandoo represented approximately 0.01% of Australia's emissions (source 'Quarterly Update of Australia's National Greenhouse Gas Inventory: June 2019, Commonwealth of Australia 2019).

The release of GHG from operational activities such as flaring, blowdown, venting and operation of vessels, helicopters and other machinery can add to the GHG load in the atmosphere which can contribute to global warming potential.

Non-GHGs are also released from operational activities such as flaring, blowdown, venting and operation of vessels, helicopters and other machinery.

Atmospheric emissions in the vicinity of the facility will be quickly dissipated into the surrounding atmosphere. Atmospheric emissions will not impact avifauna or the health or amenity of the nearest human settlements of Dampier and Karratha (over 40km away) due to the rapid dispersion of emissions.

Release of ozone depleting substances

ODS are used in closed refrigeration systems. ODS have the potential to contribute to ozone layer depletion if released to the atmosphere.

It is unlikely that ODS will be accidentally released to the atmosphere, as refrigeration systems are serviced by a third party on a regular basis to minimise the potential for accidental release.

In summary, the quantities of gaseous emissions are relatively small and will under normal circumstances, quickly dissipate into the surrounding atmosphere.

6.12.4 Risk ranking

The operations of flaring and venting from the platform, vessels, helicopter and tankers are routine with a likelihood of 'E' considered appropriate. The consequence is a '1' (Incidental) which is higher than expected however is the lowest possible consequence on the VOGA risk matrix. This results in a risk ranking of Medium.

Venting of refrigerants or ODS to atmosphere would exceed permitted conditions; however, maintenance tasks ensure no releases to atmosphere and leaks from these types of systems are very rare. Therefore, a consequence ranking of '1' and a likelihood of 'A' was considered appropriate resulting in a risk ranking of Low risk.

6.12.5 ALARP and acceptability demonstration

Whilst atmospheric emissions will occur continuously, as a result of power generation, flaring and venting, and through intermittent use of plant equipment, the risks and impacts are considered to be acceptable and ALARP as:

- Emissions associated with turbines and diesel combustion engines are associated with critical functions which could not be eliminated. Routine maintenance on turbines and replacement based on service life which will maintain the efficiency of the turbines;

- Process changes implemented in December 2020, bypassing of CFUs, will result in 5-10% reduction venting of methane to the atmosphere, with gas (mostly methane) now directed to the flare system resulting in overall greenhouse emissions reduction of 1-3%. Other low-pressure systems vent systems are currently unable to be connected to the flare system due to process safety hazards associated with integration of potentially pressurised high-pressure flammable gas systems with low pressure atmospheric tank systems;
- Proposed changes to increase produced water handling and discharge capacity will improve emissions intensity projections Wandoo operations for the remainder of field life;
- Alternative fuels which produce lower emissions, i.e. natural gas, is only feasible for the turbines and is only used in preference to diesel if reservoir conditions permit;
- During normal operation, the operating philosophy of the flare is to minimise flare gas and to operate with the pilot light burning (which is a critical safety function), i.e. flare load is intermittent based on operations and maintenance activities;
- Diesel-powered equipment on WNA and WNB (e.g. crane, firewater pumps, emergency diesel generator and portable equipment) typically use small engines and run infrequently, and therefore do not have a significant impact; and
- Usage of instrument gas on WNA is small and WNA does not have the infrastructure necessary to convert the current instrument gas system to nitrogen/compressed air.

In addition to the above, as part of Vermilion's global sustainability commitments, Vermilion Australia will continue to review emissions performance and opportunities to enhance our emissions intensity.



6.13 Artificial light

6.13.1 Hazard report

Table 6-55: Hazard report – Artificial light

HAZARD:	Artificial light					
EP risk no.:	EP-OP-R09					
Potential impacts:	Disorientation, attraction or repulsion of marine fauna and birds. Altered foraging and breeding behaviours.					
PREVENTION:						
Activity/cause:	Existing management controls	Control type	Control hierarchy	Performance outcome	Performance standard	Measurement criteria
WNA and WNB.	No controls identified as Facility lighting is specified for safe working practices.	N/A	N/A	N/A	N/A	N/A
Vessels and tankers.	No controls identified as vessel lighting is specified for safe working practices and is not permanently in the Field.	N/A	N/A	N/A	N/A	N/A
Flaring.	No controls identified.	N/A	N/A	N/A	N/A	N/A
MITIGATION:						
Existing management controls	Control type	Control hierarchy	Performance outcome	Performance standard	Measurement criteria	
None identified.	N/A	N/A	N/A	N/A	N/A	
INITIAL RISK WITH EXISTING CONTROLS:						
Consequence	Likelihood (of consequence)			Initial risk		
Incidental (1)	Almost Certain (E)			Medium risk		
ADDITIONAL CONTROLS/DEMONSTRATION OF ALARP - VOGA WORKSHOP:						
A medium risk is defined as tolerable on demonstration of ALARP under the VOGA risk level action criteria. The following ALARP analysis provides assurance that all risk treatment options have been considered.						
Additional management controls	Assessment of option				Adopted/Not adopted	
Reducing lighting levels	Current lighting levels are as required to provide a safe working environment for facility and vessel personnel, as well as to provide for navigational safety in the area. This reduction could be undertaken via limiting or excluding night time operations of impacts. However, this is not considered feasible, and given the minimal impact to EPBC Act-listed marine species (e.g., turtles) occurring due to lighting, the financial and environmental costs incurred by requiring all works to be undertaken during daylight hours only (therefore disrupting operational activities) is unfeasible and grossly disproportionate to any environmental benefit				Not adopted	
RESIDUAL RISK AFTER ADDITIONAL CONTROLS:						
Consequence	Likelihood (of consequence)			Residual risk		
Incidental (1)	Almost Certain (E)			Medium risk		
ACCEPTABLE LEVEL OF RISK DEMONSTRATED:						
Principles of ESD not compromised	External Context – objects or claims considered	Internal Context – VOGA HSE / procedures met	Other Requirements met	RR < High (RRII)	EPO(s) manage risk to acceptable level(s)	
Relevant principles of ESD not compromised given proposed controls	N/A – no external objections or claims received	Yes – managed in accordance with VOGA HSE policy	N/A	Yes – RRIII (Medium)	Yes – The following relevant overarching EPOs (Section 3.4) maintained providing control measures maintained: EPO-OP-01; EPO-OP-04; EPO-OP-05; EPO-OP-06; EPO-OP-07; EPO-OP-08; EPO-OP-09; EPO-OP-10; EPO-OP-11; EPO-OP-12; EPO-OP-13	

6.13.2 Description of hazard

Sources of artificial lighting include:

- WNA and WNB facilities lighting;
- Vessels and tankers lighting; and
- Flaring.

Lighting is required for the safe operation of the Wandoo facilities and vessels. Facility and support vessel deck lighting is kept on 24 hours a day for maritime safety purposes [Part 30 (Prevention of Collisions) of the Marine Orders made under *the Navigation Act 1912*].

6.13.3 Impact assessment

6.13.3.1 Sensitive receptors

Light-sensitive species, including pelagic fauna (fish and marine invertebrates – squid, zooplankton), marine mammals, marine turtles and seabirds.

6.13.3.2 Impact assessment criteria

No long-term disturbance to species behaviour.

6.13.3.3 Impacts

Artificial lighting in the same location may result in the following impacts to marine fauna:

- Disorientation, attraction or repulsion. Light may act as an attractant to species, affecting predator-prey dynamics; and
- Altered foraging and breeding behaviours, including increased predation risk.

6.13.3.4 Impact description

Artificial lighting has the potential to affect marine fauna by altering the use of visual cues for orientation, navigation or other purposes. This results in behavioural responses which can alter migration, foraging and breeding activity in marine reptiles, seabirds, fish and dolphins, create competitive advantages for some species, and reduce reproductive success and/or survival in others.

Previous studies have found that fish and zooplankton species are attracted to light sources (Meekan *et al.*, 2001). The attraction of organisms to the light results in an increased food source for marine predators that aggregate around the edges of the light halos. This attraction is considered to be localised and, other than some opportunistic predation, is not considered to represent a significant risk of impacts.

Artificial lighting along or adjacent to turtle nesting beaches poses a particular issue as it has the potential to alter nocturnal behaviours, particularly the selection of nesting sites and the passage of adult females and emerging hatchlings from the beach to the sea (Limpus, 2009). Turtle hatchlings are particularly sensitive to artificial light as they orientate towards light (typically the horizon/wave breaking zone) when emerging from the nest. Hatchlings attracted to artificial light

as they emerge from a nest can result in disorientation and increased risk of predation. Similarly, when hatchlings have successfully reached the ocean the attraction and congregation of hatchlings around offshore lights may increase predation from seabirds and sharks. As the WNB Facility is located approximately 40km from the nearest turtle nesting beaches (Section 4); at Dampier Archipelago and about 100km northeast of the Montebello Commonwealth Marine Reserve, lighting from the Facility will not have an impact on emergent hatchlings.

Seabirds are known to aggregate around permanent offshore structures such as platforms (Verhejen 1985; Wiese *et al.*, 2001), due to the aggregation of marine life at all trophic levels, creating food sources and shelter for seabirds (Surman, 2002). Bright lights can also disorientate birds, thereby increasing the likelihood of seabird mortality through collision with infrastructure. Studies in the North Sea indicate that migratory birds are attracted to lights on offshore platforms when travelling within a radius of 3-5km from the light source. Outside this area their migratory path will be unaffected (Marquenie *et al.*, 2008).

Light generated by flaring events is not continuous and the flare is invisible during the day. Therefore, it is unlikely to affect substantially marine fauna, and as such was not assessed further.

There is no evidence to suggest that artificial light sources adversely affect the migratory, feeding or breeding behaviours of cetaceans. Cetaceans predominantly utilise acoustic senses to monitor their environment rather than visual cues (Simmonds *et al.*, 2004). Therefore, light is not considered to be a significant factor in cetacean behaviour or survival.

6.13.4 Risk ranking

Facility and support vessel deck lighting is kept on 24 hours a day for maritime safety purposes however due to the remote location of the Facilities there is no evidence to suggest that lighting is having an impact on marine fauna. Therefore, a likelihood of 'E' was considered appropriate.

The consequence is considered to be a '1' (Incidental) which is higher than expected however is the lowest possible consequence on the VOGA risk matrix. This results in a medium risk ranking.

6.13.5 ALARP and acceptability demonstration

A review of the risks and impacts to determine that the risks are acceptable and ALARP has assessed that:

- Lighting levels will be at those required to provide a safe working environment for facility personnel, as well as for navigational safety in the area. Reduction in lighting levels would introduce navigational and occupational safety hazards, and cause non-compliance with codes and regulations. Any reduction in lighting is therefore deemed to be unacceptable. Lights on the Facility will be kept on for 24 hours a day for safety purposes in accordance with requirements of the Navigation Act 1912;
- The significant distance of the operation from sensitive receptors significantly reduces the risk of interference with natural patterns; and
- Impact to environment caused by this hazard is assessed by VOGA to be acceptable due to the relatively small impact area and the fact that alternative arrangements may result in increased environmental and safety risk.

Given the distance from any sensitive receptors and the fact that a minimum level of lighting is required and applied for safety of personnel, the risk is deemed to be acceptable and to ALARP.



6.14 Discharge of cooling water from Facility

6.14.1 Hazard report

Table 6-56: Hazard report – Discharge of cooling water from Facility

HAZARD:	Discharge of cooling water from Facility					
EP risk no.:	EP-OP-R10					
Potential impacts:	Minor thermal impacts to marine organisms. Localised reduction water quality.					
PREVENTION:						
Activity/cause:	Existing management controls	Control type	Control hierarchy	Performance outcome	Performance standard	Measurement criteria
Use of seawater for cooling compressors and turbines.	No controls identified. Seawater is used to provide cooling to machinery to ensure safe and fuel-efficient operation.	N/A	N/A	N/A	N/A	N/A
Use of marine growth prevention chemical in the seawater system.	VOGA Chemical selection process	Administrative	Substitution	Minimise impact to the marine environment from planned discharges of production chemicals.	Chemicals used in the production process that will be discharged to the marine environment are selected in accordance with the VOGA chemical assessment process (Section 7.11)	Chemical changes/new chemical to have approved MoC. Assessment of existing chemicals is outlined in the review of current process chemicals.
MITIGATION:						
Existing management controls	Control type	Control hierarchy	Performance outcome	Performance standard	Measurement criteria	
None identified.	N/A	N/A	N/A	N/A	N/A	
INITIAL RISK WITH EXISTING CONTROLS:						
Consequence	Likelihood (of consequence)			Initial risk		
Incidental (1)	Almost certain (E)			Medium risk		
ADDITIONAL CONTROLS/DEMONSTRATION OF ALARP - VOGA WORKSHOP:						
A lower range medium risk is defined as tolerable on demonstration of ALARP under the VOGA risk level action criteria. The following ALARP analysis provides assurance that all risk treatment options have been considered.						
Additional management controls	Assessment of option			Adopted/Not adopted		
Increased cooling water flow rate	The total heat load transferred to the sea is determined by process cooling requirements. Whilst an increased cooling water flow rate would reduce the cooling water discharge temperature, this would require an increase to the seawater lift pump capacity (with increase in emissions) and changes to the cooling system (with significant associated cost) which is grossly disproportionate to any environmental benefit.			Not adopted		
RESIDUAL RISK AFTER ADDITIONAL CONTROLS:						
Consequence	Likelihood (of consequence)			Residual risk		
Incidental (1)	Almost certain (E)			Medium risk		
ACCEPTABLE LEVEL OF RISK DEMONSTRATED:						
Principles of ESD not compromised	External Context – objects or claims considered	Internal Context – VOGA HSE / procedures met	Other Requirements met	RR < High (RRII)	EPO(s) manage risk to acceptable level(s)	
Relevant principles of ESD not compromised given proposed controls	N/A – no external objections or claims received	Yes – Impact managed in accordance with VOGA HSE policy and Contractor PMS.	N/A – no other requirements identified	Yes – RRIII (Medium)	Yes – The following relevant overarching EPOs (Section 3.4) maintained providing control measures maintained: EPO-OP-04; EPO-OP-05; EPO-OP-06; EPO-OP-07; EPO-OP-08; EPO-OP-09; EPO-OP-10; EPO-OP-11; EPO-OP-12; EPO-OP-13	

6.14.2 Description of hazard

Seawater is used as a heat exchange medium for the cooling of compressors and turbines. Seawater is drawn from the ocean and absorbs heat from the process being cooled.

Once the process heat is transferred into the cooling water, it is discharged overboard back to the sea. The maximum discharge rate is 1,000m³/hr and the return temperature is 2-3°C above supply temperature.

To prevent marine growth in the cooling water system, seawater is treated by a Marine Growth Preventing System which involves producing chlorine electrically and continuous dosing of hypochlorite at 2mg/L.

6.14.3 Impact assessment

6.14.3.1 Sensitive receptors

Pelagic fauna (fish and plankton), marine mammals and marine reptiles.

6.14.3.2 Impact assessment criteria

6.14.3.3 Temperature

The assessment criteria for temperature is based on the Environmental Health and Safety Guidelines for Offshore Oil and Gas Development (IFC, 2007). These guidelines recommend a temperature increase of no more than 3°C within 100m of the discharge point.

6.14.3.4 Sodium-hypochlorite concentration

Sodium-hypochlorite solution (10-15%) can cause acute and chronic toxic effects on aquatic fauna (48 hour exposure LC₅₀ 0.07 – 5.9mg/L for fish).

6.14.3.5 Impacts

Potential impacts from discharge of cooling water include:

- Thermal impacts to marine organisms; and
- Reduced dissolved oxygen concentrations and dilute sodium-hypochlorite content, leading to localised impacts on pelagic fauna.

6.14.3.6 Impact description

The cooling water is discharged to the sea. When discharged to sea, the cooling water is initially subject to turbulent mixing and some transfer of heat to the surrounding waters and atmosphere. The plume disperses and rises to the sea surface where further dilution and loss of heat will occur. The plume of heated water moves in accordance with the prevailing currents. Temperatures drop swiftly with distance from the discharge point.

Potential thermal impacts to marine organisms include alteration of the physiological processes (especially enzyme mediated processes) (Wolanski, 1994). These alterations may cause a variety of effects, ranging from behavioural response (including attraction and avoidance behaviour), to

minor stress, to potential mortality after prolonged exposure. Fish tend to avoid outfalls in the warmer (summer) months and actively enter them in winter months. Changes to breeding patterns of various invertebrates have also been noted.

The temperature of the discharge is 2°C to 3°C higher than the ambient sea temperature. These water temperatures are within the range of temperatures recorded on the NWS and naturally occurring organisms in the area would likely be tolerant of such increases. Potential thermal impacts are also limited by the dilution of the discharge and by convection losses.

Elevated seawater temperatures are known to cause alteration of the physiological processes (especially enzyme-mediated processes) of exposed biota (Wolanski, 1994). These alterations may cause a variety of effects, ranging from behavioural response (including attraction and avoidance behaviour), to minor stress, to potential mortality for prolonged exposure.

Organisms utilising surface waters include plankton, fish, marine turtles, marine mammals and seabirds.

Fish and plankton are likely to be at greatest risk from cooling water discharge impacts since they are most likely to be attracted to the discharge location (fish) or entrained within the discharge plume (plankton). Fish and plankton are also relatively small, cold blooded organisms that may experience increased body temperature and altered physiological processes (e.g. increased respiration rate and oxygen demand). However, given that the area of raised water temperature will be highly localised and within the range of temperature on the NWS significant impacts on a larger ecosystem or population level to fish or plankton are not expected to occur.

Given the localised impacts in water quality from the discharge and the lack of any natural seabed features that would indicate a high abundance or diversity of demersal fishes within the Operational Area, it is believed that discharges would have a negligible impact on the demersal fish populations of the Continental Slope Demersal Fish Communities KEF. Black et al. (1994) suggests that cooling water discharges has detrimental effects on plankton that become entrained in the cooling water plume but that the impact is likely to be localised, which is supported by Wolanski (1994). Phytoplankton photosynthesis may increase or decrease, and the breeding patterns of various invertebrates can change (Black et al., 1994).

Turtles, seabirds or marine mammals may come in contact with the cooling water discharge for a short period should the transit through the Operational Area. In addition, the Operational Area overlaps with the pygmy blue whale distribution BIA and a migration BIA for humpback whale. However, the Operational Area is not known harbour significant numbers of these species and any visits of these fauna to the Operational Area would likely be temporary only and prolonged negative impacts from raised water temperature are not expected.

The only biota that may be exposed to the thermal discharge for long periods are fouling species (e.g. barnacles), and possibly fish, marine turtles, marine mammals and seabirds in the immediate vicinity of the discharge point, or planktonic species that drift with the cooling water discharge as it disperses and decreases in temperature. The heated water will prevent species that are less tolerant to elevated temperatures from settling and becoming established in close proximity to the discharge point. However, given that the area of raised water temperature will be highly localised and within the range of temperature on the NWS, significant impacts on a larger ecosystem or population level to fish or plankton are not expected to occur.

Sodium-hypochlorite is toxic to aquatic organisms however only a low concentration is used (2mg/L) in the cooling water and the substance is extremely reactive. Sodium-hypochlorite will

react with organic matter and rapidly disperse due to turbulent mixing, therefore removed before reaching the environment and no toxic impacts on marine organisms when discharged. The cooling water additive is controlled via the chemical selection process to ensure that the lowest toxicity chemicals practicable are selected.

6.14.4 Risk ranking

Cooling water is continuously discharged into the marine environment; however, a negligible impact has been assessed from the solutions increased temperature and addition of sodium-hypochlorite. Therefore, a consequence ranking of '1' and a likelihood of 'E' was considered appropriate resulting in a Medium risk.

6.14.5 ALARP and acceptability demonstration

A review of the risks and impacts to determine that the risks are acceptable and ALARP has assessed that:

- Cooling water is required to ensure the efficient operation of turbine generators and gas lift compressors. Any reduction in cooling may lead to increased fuel consumption or equipment failure, with associated environmental impacts;
- Cooling water discharge temperature is only marginally (2-3°C) higher than the sea temperature, which is within the range of temperatures recorded on the NWS;
- The total heat load transferred to the sea is determined by process cooling requirements. Whilst an increased cooling water flow rate would reduce the cooling water discharge temperature, and increase the discharge velocity (which may improve mixing), this would require an increase to the seawater lift pump capacity (with increase in emissions) and changes to the cooling system (with significant associated cost); and
- The small quantities of sodium-hypochlorite in the discharged cooling water have no toxic impacts on marine organisms in the discharge area.

The risk associated with this discharge is therefore considered acceptable and ALARP.



6.15 Vessel and Facility deck drainage and vessel bilge water discharge

6.15.1 Hazard report

Table 6-57: Hazard report – Vessel and Facility deck drainage and vessel bilge water discharge

HAZARD:	Vessel and Facility deck drainage and vessel bilge water discharge					
EP risk no.:	EP-OP-R11					
Potential impacts:	Reduction in water quality. Toxicity effects to marine organisms in the immediate vicinity of the discharge.					
PREVENTION:						
Activity/cause:	Existing management controls	Control type	Control hierarchy	Performance outcome	Performance standard	Measurement criteria
Drainage from WNA production areas may contain oil and grease, detergents and dirt.	Biodegradable and low toxicity detergents used during wash-down activities.	Administration	Substitution	Minimise impacts to the marine environment from deck drainage on WNA via biodegradable detergents and secondary containment.	Biodegradable detergents selected in accordance with the chemical assessment process (Section 7.11) used during washdown activities.	Purchase records of detergents and SDS. Chemical assessment records.
	Drip trays or bunds are used where required to contain potential residual spills.	Engineering	Mitigation		Bunds or drip trays applied and maintained, as per the Wandoo Work Management Manual [WPA-7000-YG-0021].	Maintenance records
					Contaminated liquids from WNA drip trays and/or bunds are collected, and managed in accordance with the Waste Management Procedure [WPA-7000-YH-0009].	Visual inspection
Drainage from WNB Facility may contain oil, grease, detergents and other hazardous chemicals.	Biodegradable and low toxicity detergents used during wash-down activities.	Administration	Substitution	Minimise impacts to the marine environment from deck drainage on WNB via biodegradable detergents and secondary containment.	Biodegradable detergents selected in accordance with the chemical assessment process (Section 7.11) used during washdown activities.	Purchase records of detergents and SDS. Chemical assessment records.
	All designated chemical storage areas and hydrocarbon process areas are bunded.	Engineering	Mitigation		There shall be no significant damage or deterioration of bunded areas.	Maintenance records
	Drip trays or temporary bunds are used where required to contain potential residual spills.	Engineering	Mitigation		Bunds or drip trays applied and maintained, as per the Wandoo Work Management Manual [WPA-7000-YG-0021].	Maintenance records
	Drainage from decks in hazardous areas is collected through hazardous drain system.	Engineering	Reduction		Hazardous drains system operated and maintained, as per the Wandoo Work Management Manual [WPA-7000-YG-0021].	Visual inspection.
				Contaminated liquids from WNB drip trays and/or bunds are collected, and managed in accordance with the Waste Management Procedure [WPA-7000-YH-0009].	Visual inspection	
Drainage from vessel decks may contain oil, grease, spilled chemicals, detergent	Bulk hazardous chemicals are transported in chemical cradles.	Engineering	Reduction	Minimise impacts to the marine environment from chemical spills.	Bulk hazardous chemicals on vessels are transported in chemical cradles.	Visual inspection.
Bilge discharge from vessels.	No bilge discharge within the 500m restricted zone.	Administration	Elimination	No environmental impacts from bilge water discharge within the 500m restricted zone.	Bilge must be discharged outside 500m restricted zone, as per the Marine Operations Manual [WNB-1000-YV-0001].	VOGA Marine Operations Manual [WNB-1000-YV-0001] provided to all vessels contracted.
MITIGATION:						
Existing management controls	Control type	Control hierarchy	Performance outcome	Performance standard	Measurement criteria	



MITIGATION:					
None identified.	N/A	N/A	N/A	N/A	N/A
INITIAL RISK WITH EXISTING CONTROLS:					
Consequence	Likelihood (of consequence)			Initial risk	
Incidental (1)	Almost Certain (E)			Medium risk	
ADDITIONAL CONTROLS/DEMONSTRATION OF ALARP - VOGA WORKSHOP:					
A medium risk is defined as tolerable on demonstration of ALARP under the VOGA risk level action criteria. The following ALARP analysis provides assurance that all risk treatment options have been considered.					
Additional management controls	Assessment of option			Adopted/Not adopted	
Onshore treatment and disposal	Collecting and transporting the water onshore for treatment and disposal was considered, but rejected due to the additional potential risks associated with transportation to shore (e.g. lifting and transport and fuel-related emissions). This trade-off was considered undesirable given the limited potential impact of deck drainage to the marine environment and grossly disproportionate			Not adopted	
Enhanced treatment offshore prior to discharge	Considered grossly disproportionate due to the high cost of retrofitting additional treatment packages to the existing drains water treatment systems; and the minor environmental impact of the discharge.			Not adopted	
RESIDUAL RISK AFTER ADDITIONAL CONTROLS:					
Consequence	Likelihood (of consequence)			Residual risk	
Incidental (1)	Almost Certain (E)			Medium risk	
ACCEPTABLE LEVEL OF RISK DEMONSTRATED:					
Principles of ESD not compromised	External Context – objects or claims considered	Internal Context – VOGA HSE / procedures met	Other Requirements met	RR < High (RRII)	EPO(s) manage risk to acceptable level(s)
Relevant principles of ESD not compromised given proposed controls	N/A – no external objections or claims received	Yes – Impact managed in accordance with VOGA HSE policy and procedures	Yes – MARPOL 73/78	Yes – RRIII (Medium)	Yes – EPOs specify limits on discharges and minimisation of impacts. The following relevant overarching EPOs (Section 3.4) maintained providing control measures maintained: EPO-OP-04; EPO-OP-05; EPO-OP-06; EPO-OP-07; EPO-OP-08; EPO-OP-09; EPO-OP-10; EPO-OP-11; EPO-OP-12; EPO-OP-13

6.15.2 Description of hazard

Drainage from the production and deck areas of WNA and WNB mainly consists of wash-down water, seawater spray and rainwater, and may contain small quantities of oil and grease, detergents and dirt from the decks. The volume of drainage depends on rainfall and the frequency of deck washing. Inventory records indicate that an average of 126L of deck wash detergent is used per month.

6.15.3 Impact assessment

6.15.3.1 Sensitive receptors

Pelagic habitat and species (fish and plankton), marine mammals, and marine reptiles.

6.15.3.2 Impact assessment criteria

6.15.3.3 Hydrocarbons and chemical discharge

Toxicity to marine organisms is from trace amounts of dissolved hydrocarbons and chemicals in the oil water drainage after treatment and is similar to the impacts of PFW as described in Section 6.7.2.7.

The deck wash used on WNA and WNB is assessed in accordance with the chemical assessment process (Section 7.11) to ensure low toxicity and high biodegradability.

6.15.3.4 Impacts

The potential impacts of the discharge of deck drainage and bilge water (chemical or hydrocarbon contaminated water) are:

- Reduction in water quality (pollution) of the surrounding surface waters; and
- Toxicity to marine fauna in the immediate vicinity of the discharge.

6.15.3.5 Impact description

The Main Deck is generally used for the permanent or temporary storage of bulk fuels and/or chemicals. These areas are either fully bunded, or the deck drainage has been sealed or secondary containment is provided to prevent accidental discharges to the ocean. Bunds around engines and machinery/equipment are also connected to the closed drain system.

Contaminated liquids from WNA drip trays and/or bunds are collected and transferred into an iso-container, and managed in accordance with the Waste Management Procedure [WPA-7000-YH-0009].

An OIW monitor is used to record the oil content in any overboard discharge to ensure that the OIW content is less than 30mg/L.

When an offtake tanker is no longer moored at the CALM Buoy, it is not considered a facility and must discharge slops water with an OIW content no greater than 15mg/L (Marine Orders – Part 91 Marine Pollution Prevention Oil).

Depending on the type and volume of pollutants on the deck, the deck drainage has the potential to create ocean surface sheens and short-term, localised reduction in water quality when discharged overboard. Toxicity to marine organisms is from trace amounts of dissolved hydrocarbons in the oil water drainage after treatment and is similar to effects of PFW as described in Section 6.7.2.6.

Discharge of detergent results in the addition of inorganic nutrients and surfactants to the ocean. It is expected that nutrient addition will have little environmental consequences as the phytoplankton and microbial activity in the surrounding waters would ensure that any environmental impact would be minimal. Reduction in water quality will affect surface waters (<5m) only and the discharged water would be rapidly diluted in the dynamic oceanic environment.

The greatest risk at the WNB Platform location will be to plankton and pelagic fish. However, given the biodegradability/low persistence of the wastes, and the minimal volumes involved, the impact on the surrounding water quality would be temporary and localised. As a result, it is not expected that marine fauna or plankton will be exposed to chemicals or hydrocarbons in quantities that would induce acute or chronic toxicity impacts.

Surfactants are typically toxic to marine life however, dispersion and dilution of discharges is expected to be rapid also resulting in minor, short-term changes to water quality.

6.15.4 Risk ranking

A number of controls are in place on WNA and WNB to ensure that contaminants within deck drainage are negligible. A likelihood of 'E' was considered appropriate given the routine nature of the hazard. The consequence is considered to be a '1' (Incidental) which is higher than the negligible impact expected however is the lowest possible consequence on the VOGA risk matrix. This results in a medium risk ranking.

6.15.5 ALARP and acceptability demonstration

A review of the risks and impacts to determine that the risks are acceptable and ALARP has assessed that:

- Deck washing using a detergent is an essential activity to prevent deck surfaces becoming slippery and increasing the risk of personnel being injured. Not utilising detergent makes the activity ineffective as the water cannot remove oil and grease. In addition, oil and grease may spread further across decks, increasing the risk of personnel being injured;
- Formalisation of the current field practice that 'no bilge discharge from vessels within the 500m restricted zone' was required to support management of this risk to ALARP;
- VOGA revised the Marine Operations Manual in 2016 to include no bilge discharge from vessels within the exclusion zone and to formalise the requirement for bulk hazardous chemical transport at sea.

The following alternatives to discharge of deck drainage were considered but not implemented:

- Onshore treatment was considered, but rejected due to the additional potential risks associated with transportation to shore (e.g. lifting and transport and fuel-related emissions). This trade-off was considered undesirable given the limited potential impact of deck drainage to the marine environment; and

- Similarly, enhanced treatment prior to disposal was considered, but rated as undesirable due to the high cost of retrofitting additional treatment packages to the existing drains water treatment systems;

No further practical control measures could be identified; therefore, the risk is considered ALARP.

Impact to the environment caused by this hazard is assessed by VOGA to be acceptable due to the relatively small impact area, and that alternative arrangements may result in a larger environmental and safety impact. The described controls and mitigation strategies reduce the risks associated with the use of biodegradable detergents to an acceptable level and reduce the risk to ALARP.



6.16 Discharge of sewage, greywater and putrescible waste from Facility and vessels

6.16.1 Hazard report

Table 6-58: Hazard report – Discharge of sewage, greywater and putrescible water from Facility and vessels

HAZARD:	Discharge of sewage, greywater and putrescible waste from Facility and vessels					
EP risk no.:	EP-OP-R12					
Potential impacts:	Nutrient enrichment and increased biological demand of surrounding waters. Low level contamination of organisms caused by ingestion of waste materials. Increase in scavenging behaviour of marine fauna and seabirds.					
PREVENTION:						
Activity/cause:	Existing management controls	Control type	Control hierarchy	Performance outcome	Performance standard	Measurement criteria
Greywater discharged from the Facility.	Sewage effluent from the WNB Platform is macerated to pass through a 25mm mesh (as required under MARPOL).	Engineering	Reduction	Reduce the impact of planned discharge of sewage, greywater and putrescible wastes into the marine environment by increasing the bioavailability of waste prior to disposal.	Sewage and greywater system will comply with the requirements of MARPOL 73/78 Annex IV.	Sewage system specifications
	Food waste from the WNB Platform is macerated to pass through a 25mm mesh (as required under MARPOL).	Engineering	Reduction		Sewage system is functional and maintained in accordance with maintenance procedure for sewage macerator.	Maintenance records.
Greywater discharged from support vessels.	Vessels >400T or certified for >15 persons must comply with MARPOL 73/78 (Annex IV; Regulation 8)	Administrative	Reduction		Vessel contractor procedures include the requirements to comply with MARPOL 73/78 (Annex IV; Regulation 8) as required by class: <ul style="list-style-type: none"> Equipped with either a sewage treatment plant or sewage comminuting and disinfecting system or a sewage holding tank; Wastes shall be macerated to <25mm prior to discharge; and Untreated sewage will be stored on-board in suitable holding tanks and disposed of onshore at reception facility or to carrier licensed to receive the waste, or discharged at distance of more than 12 nautical miles from nearest land. 	Vessel international Sewage Pollution Prevention Certificate
MITIGATION:						
Existing management controls	Control type	Control hierarchy	Performance outcome	Performance standard	Measurement criteria	
None identified.	N/A	N/A	N/A	N/A	N/A	
INITIAL RISK WITH EXISTING CONTROLS:						
Consequence	Likelihood (of consequence)			Initial risk		
Incidental (1)	Almost Certain (E)			Medium risk		



INITIAL RISK WITH EXISTING CONTROLS:					
ADDITIONAL CONTROLS/DEMONSTRATION OF ALARP - VOGA WORKSHOP:					
A medium risk is defined as tolerable on demonstration of ALARP under the VOGA risk level action criteria. The following ALARP analysis provides assurance that all risk treatment options have been considered.					
Additional management controls		Assessment of option			Adopted/Not adopted
Onshore disposal		All food scraps, sewage and grey waste transported to shore for land-based disposal. This would result in an increase in transportation requirements (and increased atmospheric emissions, safety risk and cost). Onshore disposal would have environmental impacts that may be greater than those created by offshore disposal, e.g. added energy needed (and associated emissions) for sewage and greywater treatment. It also provides an increased exposure to biological health hazards, and considered grossly disproportionate to any environmental benefit gained.			Not adopted
RESIDUAL RISK AFTER ADDITIONAL CONTROLS:					
Consequence		Likelihood (of consequence)		Residual risk	
Incidental (1)		Almost Certain (E)		Medium risk	
ACCEPTABLE LEVEL OF RISK DEMONSTRATED:					
Principles of ESD not compromised	External Context – objects or claims considered	Internal Context – VOGA HSE / procedures met	Other Requirements met	RR < High (RRII)	EPO(s) manage risk to acceptable level(s)
Relevant principles of ESD not compromised given proposed controls	N/A – no external objections or claims received	Yes – Impact managed in accordance with VOGA HSE policy and procedures	Yes – MARPOL 73/78	Yes – RRIII (Medium)	Yes – EPOs specify limits on discharges and minimisation of impacts. The following relevant overarching EPOs (Section 3.4) maintained providing control measures maintained: EPO-OP-04; EPO-OP-05; EPO-OP-06; EPO-OP-07; EPO-OP-08; EPO-OP-09; EPO-OP-10; EPO-OP-11; EPO-OP-12; EPO-OP-13

6.16.2 Description of hazard

Sewage from the Platform consists mainly of sanitary waste, greywater and a small component of macerated food waste. The volume of sewage effluent produced has been estimated on an average sewage production (human waste and associated toilet water etc.) of 60L per person per day. The mass of nutrients discharged in sewage effluent from the WNB Platform was estimated to include 1.6kg per month of nitrogen and 0.38kg per month of phosphorus. In addition, there is a small volume of biodegradable organics.

Greywater is discharged from the laundry, shower and hand basins from the fixed facility, vessels and tankers. The estimated volume of greywater produced was based on an average water consumption of 140L per person per day. The greywater is comprised of potable water, soaps and detergents and is discharged directly to the ocean.

Putrescible waste is generated from food scraps from the kitchens on the Platform and support vessels. The food scraps are macerated to a size small enough to pass through a 25mm mesh (as per the requirements of MARPOL) prior to discharge overboard. The volume of putrescible waste discharged overboard is estimated at 1.9L per person per day. Scraps that cannot be macerated or are not readily degradable (e.g. bones) are bagged and disposed of onshore with the general waste.

6.16.3 Impact assessment

6.16.3.1 Sensitive receptors

Pelagic habitat and species (fish and plankton), marine mammals, marine reptiles and seabirds.

6.16.3.2 Impact assessment criteria

Sewage, greywater and putrescible waste generated at the Facility is treated to comply with the discharge requirements of MARPOL 73/78 Annex IV and *Protection of the Sea (Prevention of Pollution from Ships) Act 1983*.

6.16.3.3 Impacts

The known and potential impacts of sewage, greywater and putrescible waste discharge are:

- Nutrient enrichment and increased biological oxygen demand of surrounding waters;
- Low level contamination of organisms caused by ingestion of waste materials; and
- Increase in scavenging behaviour of marine fauna and seabirds.

6.16.3.4 Impact description

6.16.3.5 Sewage and greywater

Sewage and greywater generated at the Facility and on support vessel is treated to comply with the discharge requirements of MARPOL 73/78 Annex IV and *Protection of the Sea (Prevention of Pollution from Ships) Act 1983*.

The primary concerns related to the discharge of sewage, greywater and putrescible waste are nutrient enrichment of surrounding waters and increased biological oxygen demand, resulting in changes to plankton in the immediate area. In a study of sewage discharge in deep ocean waters, Friligos (1985) reported no appreciable differences in the inorganic nutrient levels between the outfall area and background concentrations, suggesting rapid uptake of nutrients and/or rapid dispersion in the surrounding waters.

Wastewater discharges into the open ocean have little potential for impact where the waters are well mixed, and the volume of discharge is relatively small. Any wastewater discharged from the Wandoo Platform will be dispersed due to the wind-driven surface water currents, and rapidly mixed through the surface layer of water. The process of mixing and dilution is considered in further detail in Section 6.7.

In the context of the total volume of PFW discharged from the Facility on a daily basis, the daily load of degradable organics from the sewage and putrescible waste is inconsequential, with little likelihood of oxygen depletion in receiving waters (Black *et al.*, 1994).

Ingestion of sewage discharges by fish, cetaceans, marine reptiles or foraging seabirds could result in bioaccumulation of contaminants however dilution is rapid with results showing 1-in-1,000 dilution within 30 minutes (Costello and Read, 1994).

The potential for saprogenic (oxygen depletion) or toxic effects is also very low due to the open ocean environment with rapid dilution and dispersal from wave and current effects. In the open oceanic environment, the effect of the effluent biological oxygen demand on seawater oxygen concentrations is expected to be insignificant (Black *et al.*, 1994). Surface currents will also assist with oxygenation of the discharge once it is released.

As the volume of sewage and greywater discharged per day is relatively small due to the number of people working at the Facility, sewage and greywater discharge is unlikely to have a significant environmental impact.

The smaller support vessels usually do not have on-board sewage treatment facilities and discharge their macerated blackwater and greywater effluent either beyond the 12 nautical mile limit from the coast or into sewage holding tanks at their home port (Port of Dampier).

6.16.3.6 Putrescible waste

Food scraps will be macerated to a size small enough to pass through a 25mm mesh (as required under MARPOL) and discharged overboard. The overboard discharge of macerated food wastes would create a localised and temporary increase in the nutrient load of the surface waters. This may in turn act as a food source for scavenging marine fauna or seabirds, resulting in a localised increase of scavenging species around the Facility. The rapid consumption of this food waste by scavenging fauna, and physical and microbial breakdown, ensures that the impacts of putrescible waste discharges are insignificant. The small volume of food scraps relative to the total biological productivity of the area means that the environmental effect of their discharge would be insignificant.

Biodegradable matter (i.e. macerated food scraps and sewage) may result in localised increases in nutrient levels, which may stimulate microbial activity and therefore act as a food source for scavenging birds and/or animals.

Given the Facilities location, there are no nearby sensitive environments or biological communities that are at risk from the discharge of sewage, greywater or putrescibles wastes. Sewage and sullage effluent from the Platform and support vessels will be subject to rapid dilution and dispersion by the prevailing currents and waves. It is likely that the highly dispersive marine environment and high water column productivity are preventing long-term accumulation of organics under the Facility.

While marine mammals and reptiles may transit through the area, there are no feeding, breeding or other aggregation areas nearby.

6.16.4 Risk ranking

Sewage, greywater and putrescible waste generated at the Facility is treated to comply with international discharge requirements with negligible impacts to the environment. A likelihood of 'E' was considered appropriate given the routine nature of the hazard. The consequence is considered to be a '1' (Incidental) which is higher than the negligible impact expected however is the lowest possible consequence on the VOGA risk matrix. This results in a medium risk ranking.

6.16.5 ALARP and acceptability demonstration

A review of the risks and impacts to determine that the risks are acceptable and ALARP has assessed that:

- An alternative to disposal at sea would be to take all food scraps, sewage and grey waste to shore for land-based disposal. From a logistics perspective, this would mean an increase in transportation requirements along with associated increases in atmospheric emissions, safety risk and cost. In addition, onshore disposal would have environmental impacts that may be greater than those created by offshore disposal, e.g. added energy needed (and associated emissions) for sewage and greywater treatment. It also provides an increased exposure to biological health hazards;
- The volume of sewage and greywater per person is consistent irrespective of their location; the difference here is the discharge location and treatment. The capital, operational and maintenance cost associated with adding a secondary sewage treatment facility is prohibitive for the environmental benefit achieved. This is because this measure will come with its own environmental impacts associated with the treatment process and the actual impact reduction is negligible;
- Impacts to the marine environment are expected to be minimal because of the biodegradability of the waste, non-continuous nature of the discharges and the large dilution factor in the open ocean environment. The existing control measures reduce the associated risks to ALARP; and
- Impact to environment is over a relatively small area due to the relatively small volumes.

Based on the above, there is no additional control measures required to manage the impact of this environmental risk.



6.17 Discharge of desalination brine

6.17.1 Hazard report

Table 6-59: Hazard report – Discharge of desalination brine

HAZARD:	Discharge of desalination brine					
EP risk no.:	EP-OP-R13					
Potential impacts:	Localised elevation in seawater salinity. Localised reduction in water quality.					
PREVENTION:						
Activity/cause:	Existing management controls	Control type	Control hierarchy	Performance outcome	Performance standard	Measurement criteria
Wastewater discharged from the reverse osmosis desalination plant.	No controls were identified, and none are believed to be required.	N/A	N/A	N/A	N/A	N/A
Discharge of back flush water from potable water system containing Scale Inhibitor.	Chemical assessment and selection process	Administrative	Substitution	Minimise impact to the marine environment from planned discharges of production chemicals.	Chemicals used in the production process that will be discharged to the marine environment are selected in accordance with the chemical assessment process.	Chemical changes/new chemical to have approved MoC. Assessment of existing chemicals is outlined in the review of current process chemicals.
MITIGATION:						
Existing management controls	Control type	Control hierarchy	Performance outcome	Performance standard	Measurement criteria	
None identified.	N/A		N/A	N/A	N/A	
INITIAL RISK WITH EXISTING CONTROLS:						
Consequence	Likelihood (of consequence)			Initial risk		
Incidental (1)	Almost Certain (E)			Medium risk		
ADDITIONAL CONTROLS/DEMONSTRATION OF ALARP - VOGA WORKSHOP:						
Medium risk is defined as tolerable on demonstration of ALARP under the VOGA risk level action criteria. The following ALARP analysis provides assurance that all risk treatment options have been considered.						
Additional management controls	Assessment of option				Adopted/Not adopted	
Alternative supply of potable water	Means of transportation which would introduce/increase other environmental impact, increased safety risk and cost. This trade-off was considered undesirable and grossly disproportionate given the limited potential impact of desalination brine to the marine environment.				Not adopted	
RESIDUAL RISK AFTER ADDITIONAL CONTROLS:						
Consequence	Likelihood (of consequence)			Residual risk		
Incidental (1)	Almost Certain (E)			Medium risk		
ACCEPTABLE LEVEL OF RISK DEMONSTRATED:						
Principles of ESD not compromised	External Context – objects or claims considered	Internal Context – VOGA HSE / procedures met	Other Requirements met	RR < High (RRII)	EPO(s) manage risk to acceptable level(s)	
Relevant principles of ESD not compromised given proposed controls	N/A – no external objections or claims received	Yes – Impact managed in accordance with VOGA HSE policy and procedures	Yes – VOGA chemical assessment process aligns with OPSAR, OCNS and IFC guidance.	Yes – RRIII (Medium)	Yes – EPOs specify compliance with regulatory guidance. The following relevant overarching EPOs (Section 3.4) maintained providing control measures maintained: EPO-OP-04; EPO-OP-05; EPO-OP-06; EPO-OP-07; EPO-OP-08; EPO-OP-09; EPO-OP-10; EPO-OP-11; EPO-OP-12; EPO-OP-13	

6.17.2 Description of hazard

Desalination brine is discharged from the reverse osmosis desalination plant that produces potable water from seawater for use on WNB (approximately 500m³/day). The salinity of the discharged desalination brine is slightly higher than seawater and also contains small quantities of scale inhibitor. On average, seawater has a salt concentration of 35,000ppm, while the desalination discharge has a salt concentration in the range of about 38,500 to 40,000ppm.

6.17.3 Impact assessment

6.17.3.1 Sensitive receptors

Pelagic habitat and species (fish and plankton), marine mammals, marine reptiles and seabirds.

6.17.3.2 Impact assessment criteria

Salinity is a vital environmental parameter for marine life, but increased salinity can also be harmful to marine life. Toxicity will depend on the sensitivity of a species to increased salt levels, its life cycle stage, the exposure time and the natural salinity variations of the habitat to which the species is adapted (Latterman, 2010).

6.17.3.3 Impacts

The potential impacts of desalination brine discharge on the environment include:

- Temporary increase in near-surface water salinity, leading to localised impacts to water quality and pelagic fauna; and
- Alteration of physiological processes of exposed biota.

6.17.3.4 Impact description

Upon discharge to the sea, the desalination brine, being of greater density than seawater, will sink and disperse in the currents. The largest increase of salinity will be experienced in the immediate vicinity of the discharge point. The near-field dilution will occur rapidly resulting in a return to ambient salinity levels within 10m of the discharge (Raventos *et al.*, 2006). Other studies have also confirmed that elevated salinity declines rapidly close to the discharge, even where simple diffusers are utilised (Fernandez-Torquemada *et al.*, 2005).

As most marine species are able to tolerate short-term fluctuations in salinity in the order of 20% to 30% (Walker and McComb, 1990), it is expected that pelagic species would be able to tolerate the short-term exposure to the slight increase in salinity caused by the discharged desalination brine, and therefore minimal environmental impact is predicted.

For large marine species that may temporarily use surface water around platforms, such as marine turtles, mammals and seabirds, the effect of a slight increase in salinity is expected to be negligible. In addition, there are no sensitive environmental receptors in close vicinity to the Platform or is there likely to be any local aggregations of sensitive marine fauna. Therefore, impacts are likely to be negligible.

Dilution to background salinity is expected to occur in the immediate vicinity of the discharge point and well within the 500m restricted area. The relatively small volumes involved would mean

that no change in salinity would be detectable outside a very localised area. Therefore, no biological impact is likely to result from salinity variations.

Low concentrations of scale inhibitor are also discharged with the reject water. The scale inhibitor used is classified as non-hazardous and non-toxic. Further dilution of the scale inhibitor would also occur on entering the ocean, hence the discharge of scale inhibitor with the reject water is unlikely to result in any environmental effect.

6.17.4 Risk ranking

The potential impact is negligible given minor volumes of contaminants involved. A likelihood of 'E' was considered appropriate given the routine nature of the hazard. The consequence is considered to be a '1' (Incidental) which is higher than the negligible impact expected however is the lowest possible consequence on the VOGA risk matrix. This results in a medium risk ranking.

6.17.5 ALARP and acceptability demonstration

A review of the risks and impacts to determine that the risks are acceptable and ALARP has assessed that:

- It is critical that the Facility is supplied with sufficient potable water quantities for domestic use;
- The impact area is small as the salt concentration in the discharged brine is only slightly higher than the surrounding seawater. Also, the velocity of the discharge stream will facilitate rapid mixing and dilution of the brine; and
- Alternative arrangements for the provision of potable water would require means of transportation which will have a bigger environmental impact, increased safety risk and cost.

Impact to environment caused by this hazard is assessed by VOGA to be acceptable due to the very small change in ambient salinity over a localised area. The Scale Inhibitor used is at a very low concentration and will rapidly dilute and disperse through the water column. The risk associated with this discharge is therefore considered ALARP.



6.18 Disturbance to marine fauna and seabirds

6.18.1 Hazard report

Table 6-60: Hazard report – Disturbance to marine fauna and seabirds

HAZARD:	Disturbance to marine fauna and seabirds (from logistics activities)					
EP risk no.:	EP-OP-R16					
Potential impacts:	Potential injury/death and/or temporary and localised displacement of marine fauna or seabirds. Marine fauna and seabirds may be protected.					
PREVENTION:						
Activity/cause:	Existing management controls	Control type	Control hierarchy	Performance outcome	Performance standard	Measurement criteria
Marine operations including diving, ROV, supply, bunkering and export activities.	The interaction of vessels with cetaceans within the Wandoo Field will be consistent with the EPBC Regulations (2000) where practicable.	Administrative	Reduction	Manage the risk to marine fauna by reducing interactions with vessels.	The interaction of vessels with cetaceans within the Wandoo Field will be consistent with the EPBC Regulations (2000) where practicable, as identified in the Marine Operations Manual [WNB-1000-YV-0001].	VOGA Marine Operations Manual [WNB-1000-YV-0001] provided to all vessels contracted.
Helicopter movements.	No controls identified as the duration of take-off and landing at the Facility is short and impact of the activity to seabirds is negligible.	N/A	N/A	N/A	N/A	N/A
Presence of logistical equipment on unstaffed facilities	Use of coverings on open top storage skips on WNA	Engineering	Reduction	Prevent the entrapment of birds on WNA	Covers intact and fitted to all open top storage skips on WNA	Guidelines for visiting WNA Checklist (WNA-014-103) records
	Inspection for entrapped, injured and deceased birds on WNA	Administrative	Reduction		Inspection for entrapped, injured and deceased birds on WNA undertaken	Guidelines for visiting WNA Checklist (WNA-014-103) records
MITIGATION:						
Existing management controls		Control type	Control hierarchy	Performance outcome	Performance standard	Measurement criteria
None identified.		N/A	N/A	N/A	N/A	N/A
INITIAL RISK WITH EXISTING CONTROLS:						
Consequence		Likelihood (of consequence)			Initial risk	
Incidental (1)		Possible (C)			Medium Risk	
ADDITIONAL CONTROLS/DEMONSTRATION OF ALARP - VOGA WORKSHOP:						
A medium risk is defined as acceptable and typically do not require special attention outside of normal activities under the VOGA risk level action criteria. The following ALARP analysis provides assurance that all risk treatment options have been considered.						
Additional management controls		Assessment of option			Adopted/Not adopted	
Dedicated Marine Fauna Observer on vessels.		Improved ability to spot and identify marine fauna at risk of impact from vessels. Additional cost of contracting specialist Marine Fauna Observers while the risk to all EPBC Act-listed marine fauna cannot be reduced due to unpredictable presence of some species. Vessel masters are keeping watch. Cost disproportionate to increase in environmental benefit.			Not adopted.	
Eliminate use of support vessels		Disturbances to marine fauna due to vessel activities are expected to be negligible as the number of vessel activities required are minimal. Elimination of support vessels from the field would not achieve VOGA legal requirements for petroleum production or its work-plan objectives for oil and gas production and may compromise safety standards for other marine users.			Not adopted	
RESIDUAL RISK AFTER ADDITIONAL CONTROLS:						
Consequence		Likelihood (of consequence)			Residual risk	
Incidental (1)		Possible (C)			Medium Risk	
ACCEPTABLE LEVEL OF RISK DEMONSTRATED:						



Principles of ESD not compromised	External Context – objects or claims considered	Internal Context – VOGA HSE / procedures met	Other Requirements met	RR < High (RRII)	EPO(s) manage risk to acceptable level(s)
Relevant principles of ESD not compromised given proposed controls	N/A – no external objections or claims received	Yes – Impact managed in accordance with VOGA HSE policy and procedures	Yes – EPBC Regulations (2000)	Yes – RRIII (Medium)	Yes – EPOs manage risk to marine fauna. The following relevant overarching EPOs (Section 3.4) maintained providing control measures maintained: EPO-OP-05; EPO-OP-06; EPO-OP-07; EPO-OP-08; EPO-OP-09; EPO-OP-10; EPO-OP-11; EPO-OP-12; EPO-OP-13

6.18.2 Description of hazard

The movement of offtake tankers, supply vessels and helicopters has the potential to cause interference with or possibly (for vessels) to collide with marine fauna.

The presence of open top storage skips on the unstaffed WNA has the potential to entrap birds.

In-field vessel movements at the Wandoo Facility are estimated to be twice per week. Tanker movements occur at three-to-five week intervals. It is estimated that helicopter movements at the Wandoo Facility are in the order of four to five per week.

6.18.3 Impact assessment

6.18.3.1 Sensitive receptors

Marine mammals, marine reptiles and seabirds.

6.18.3.2 Impact assessment criteria

No disturbance to aquatic fauna and seabirds from vessel and helicopter movements, and presence of storage skips on WNA

6.18.3.3 Impacts

The presence and movement of vessels has the potential for physical and/or behavioural impact on marine fauna including injury/mortality from vessel strike and/or temporary and localised displacement due to physical presence.

The presence of open top storage skips on the not normally staffed WNA has the potential for physical impact on marine fauna including injury/mortality from entrapment. description

Marine fauna that are present in surface waters are most susceptible to vessel strike due to their proximity to the vessel (hull, propeller or equipment) and their limited ability to avoid vessels (i.e. diving). The species of marine fauna that are likely to be most susceptible to vessel strike include turtles and cetaceans (e.g. whales and dugongs).

All other marine fauna species including seabirds, cetaceans (dolphins) and fish species (including whale sharks) are likely to avoid any moving vessels and are considered at low risk of potential vessel strike.

Cetaceans including humpback whales demonstrate a variety of behaviours in response to approaching vessels (attributed to vessel noise), including longer dive times and moving away from the vessel's path with increased speed (Baker and Herman, 1989; Meike *et al.*, 2004). These behaviours may contribute to reducing the likelihood of a vessel strike. While there is significant vessel traffic transiting from ports in the North West and Fremantle, the International Whaling Commission (IWC) suggests that the level of ship strike in Australia is low. According to recent ship strike reports, between six and nine vessel cetacean strikes, including non-fatal cases, have been reported for the past three years (IWC, 2009, 2010, 2011).

The Operational Area is approximately 80km off the coast in water approximately 55m deep. As a result, the in-field vessel operations will be carried out some distance from shallow water habitats

and from mainland and island shorelines and beaches used by turtles. The Operational Area is not known to support critical breeding, feeding or calving areas for EPBC listed species. However, the area is within the northern migration route for humpback whales.

During the movement of the supply vessel and offtake tanker into or out of the Operational Area, or between the WNB platform and WNA monopod, it will be moving slowly (3 knots or less), allowing time for any marine fauna to move out of the immediate area. As a result, it is highly unlikely that there will be any collision with marine species. The vessels supporting the operational activities will endeavour to maintain safe distances from any whales sighted.

Although helicopter movements have the potential to affect birds through direct strike, due to the high visibility and noise levels associated with helicopter movements, birds are expected to avoid collisions with helicopters. The number of helicopter flights required is relatively low at approximately four to five per week. Flights also occur in the daylight and not within major roosting areas, thereby reducing potential interactions and subsequent physiological impacts. Collisions are therefore considered unlikely.

Based on the EPBC protected matters search only one EPBC listed bird species; the southern giant petrel (*Macronectes giganteus*) is likely to transit through the Operational Area (Section 4). Reports and sightings from the facility have indicated the presence of Brown Booby (*Sula leucogaster*) seabirds (EPBC Listed – Migratory) transiting through the Operational Area and roosting on the not normally staffed WNA. Potential for birds to become entrapped in open top storage skips used in logistics activities exists and to prevent birds getting trapped the use of covers and inspection of WNA has been implemented.

6.18.4 Risk ranking

Vessel and helicopter movements are routinely operated out to the Wandoo Operational Area, however disruption and impact to marine fauna is unlikely. Therefore, a consequence ranking of '2' and a likelihood of 'B' was considered appropriate resulting in a risk ranking of Low risk.

The risk presented by the presence of storage skips on WNA was considered a '1' consequence and a likelihood of 'C' for this consequence given the potential presence of EPBC listed species (Brown Booby) on WNA and the potential for their entrapment causing injury or mortality. This resulted in a risk ranking of Low.

6.18.5 ALARP and acceptability demonstration

The potential impact of disturbance to marine fauna and seabirds is lower medium, and is managed by controls outlined in EPBC Regulations to manage vessel interaction with marine mammals and operational procedures for WNA to manage the risk of entrapment of seabirds.

Application of the described control and mitigation measures ensures that the risk is acceptable and ALARP.



6.19 Liquid hydrocarbon release from topsides process

6.19.1 Hazard report

Table 6-61: Hazard report – Liquid hydrocarbon release from topsides process

HAZARD:	Liquid hydrocarbon release from topsides process					
EP risk no.:	EP-OP-R17					
Potential impacts:	Liquid hydrocarbon release of up to 100m ³ of oil to sea.					
PREVENTION:						
Activity/cause:	Existing management controls	Control type	Control hierarchy	Performance outcome	Performance standard	Measurement criteria
Loss of integrity of liquid hydrocarbon containing equipment.	Asset integrity management	Administration	Prevention	No release of liquid hydrocarbon from topsides process equipment to the marine environment due to loss of integrity of hydrocarbon containing equipment.	Performance criteria, as per WAN-WNAB-CP-PR-04-04 – Integrity Management. The integrity of critical elements shall be maintained at all times.	Assurance records, as per WAN-WNAB-CP-PR-04-04 – Integrity Management.
	Pipework and pressure vessel containment	Administration	Prevention		Performance criteria, as per Hydrocarbon Containment (Static Equipment) Performance Standard (WAN-WNAB-CP-PR-01): Pipework and pressure vessels shall be inspected for defects, damage or deterioration	Assurance records, as per Hydrocarbon Containment (Static Equipment) Performance Standard (WAN-WNAB-CP-PR-01):
	Pressure safety devices to prevent overpressure leading to loss of containment.	Administration	Prevention		Performance criteria, as per Pressure Relief Devices Performance Standard (WAN-WNAB-CE-PR-04): Pressure relief devices protecting equipment with defined flammable inventories shall be managed	Assurance records, as per Pressure Relief Devices Performance Standard (WAN-WNAB-CE-PR-04):
	Vessels are designed and tested to maximum allowable operating pressure.	Administration	Prevention		Performance criteria, as per Hydrocarbon Containment (Static Equipment) Performance Standard (WAN-WNAB-CP-PR-01): <ul style="list-style-type: none"> Pipework and pressure vessels shall be inspected for defects, damage or deterioration 	Assurance records, as per Hydrocarbon Containment (Static Equipment) Performance Standard (WAN-WNAB-CP-PR-01):
	Rotating equipment containment	Engineering	Prevention		Performance criteria, as per Rotating Equipment Performance Standard (WAN-WNAB-CE-PR-03) Rotating equipment shall be maintained to prevent the loss of containment of hydrocarbons	Assurance records, as per Rotating Equipment Performance Standard (WAN-WNAB-CE-PR-03)
	Instrumentation initiators, alarms and final elements.	Engineering	Prevention		Performance criteria to ensure maintenance and inspection of instrumentation initiators, alarms and final elements relevant to topsides hydrocarbon containment, as per the following: <ul style="list-style-type: none"> Instrument Protective and Alarm Systems (WAN-WNAB-CE-DC-02) Integrated Control System (WAN-WNAB-CE-DC-07) Shutdown Valves (WAN-WNAB-CE-DC-03) Blowdown (Vent and Flare) (WAN-WNAB-CE-DC-04) 	Assurance records, as per following performance standards: <ul style="list-style-type: none"> Instrument Protective and Alarm Systems (WAN-WNAB-CE-DC-02) Integrated Control System (WAN-WNAB-CE-DC-07) Shutdown Valves (WAN-WNAB-CE-DC-03) Blowdown (Vent and Flare) (WAN-WNAB-CE-DC-04)



Activity/cause:	Existing management controls	Control type	Control hierarchy	Performance outcome	Performance standard	Measurement criteria
	Competency management of Wandoo personnel.	Administration	Reduction		All offshore personnel shall have the required level of role-specific training and be assessed as competent to perform their duties in alignment with the VOGA Training and Competency Performance Standard.	Training and competency records
Human error during process break-ins.	Isolation controls to ensure adequate drainage, venting and positive isolation prior to performing a process break-in.	Administration	Prevention	No release of hydrocarbon from topsides process equipment to the marine environment due to process break-ins.	Equipment and/or facilities are adequately prepared for work activities to be performed, including safe and environmentally sound draining, venting, purging and isolation. Equipment and/or facilities are reinstated to a safe and environmentally sound working condition after the work activity is completed, and that appropriate personnel are made aware of the revised equipment status.	Isolation records on permit to work forms are completed in accordance with the Work Management Manual [WPA-7000-YG-0021].
Process upsets resulting in unplanned hydrocarbon release through produced water discharge.	Instrument protective and alarm systems (interface level low level trips in production and second stage separators).	Engineering	Reduction	Prevent the release of hydrocarbon to the marine environment due to oil/water interface control in production and second stage separators.	Level transmitters in production and second stage separators are maintained	Maintenance records
Dropped objects/ swinging loads onto topsides equipment.	Lifting management procedures.	Administrative	Reduction	Maintain sufficient integrity so that loads or any lifting component does not fall in such a manner that it may cause, or contribute, to a release of hydrocarbon to the marine environment.	Crane operations managed as per the Crane Operations, Maintenance and Inspection Manual [WPA-7000-YM-0002].	Crane Operator Checklist completed prior to crane operation.
	Crane maintenance.	Engineering	Prevention		Performance criteria, as per WAN-WNAB-CE-PR-05-01 - Platform Cranes and Man-riding Winch. Safely performs lifting operations to prevent dropped objects or swinging loads.	Assurance records, as per WAN-WNAB-CE-PR-05-01 - Platform Cranes and Man-riding Winch.

MITIGATION:

Existing management controls	Control type	Control hierarchy	Performance outcome	Performance standard	Measurement criteria
Platform ESD.	Engineering	Mitigation	Mitigate the impact of a hydrocarbon release from topsides process equipment to the marine environment.	Refer to instrumentation initiators, alarms and final elements control and performance criteria in Prevention section of hazard table above.	Assurance records
Topsides hazardous drains and bunding on WNB.	Engineering	Mitigation		There shall be no significant damage or deterioration of bunded areas on WNB such that the system will not contain hydrocarbons.	Maintenance records
Wandoo Emergency Response Plan [VOG-2000-RD-0017].	Administrative	Mitigation		The Wandoo Emergency Response Plan [VOG-2000-RD-0017] shall meet the performance criteria as per WAN-WNAB-CP-ER-01 – Emergency preparedness, managements and response	Assurance criteria as per WAN-WNAB-CP-ER-01 - Emergency preparedness, managements and response.
Oil spill response arrangements	Administrative	Mitigation		Performance criteria, as per WAN-WNAB-CP-ER-02; WAN-WNAB-CP-ER-03, WNAB-CP-ER-01-05 and WNAB-CP-ER-01-06 (refer to Hazard EP-OP-R01 Table 6-2)	Assurance activities, as per WAN-WNAB-CP-ER-02; WAN-WNAB-CP-ER-03, WNAB-CP-ER-01-05 and WNAB-CP-ER-01-06

INITIAL RISK WITH EXISTING CONTROLS:

Consequence	Likelihood (of consequence)	Initial risk
Minor (2)	Unlikely (B)	Low risk

ADDITIONAL CONTROLS/DEMONSTRATION OF ALARP - VOGA WORKSHOP:

A low risk is defined as acceptable and typically do not require special attention outside of normal activities under the VOGA risk level action criteria. The following ALARP analysis provides assurance that all risk treatment options have been considered.



ADDITIONAL CONTROLS/DEMONSTRATION OF ALARP - VOGA WORKSHOP:					
Additional management controls		Assessment of option			Adopted/not adopted
Refer to Section 6.2.7 for oil spill response ALARP evaluation tables.					
RESIDUAL RISK AFTER ADDITIONAL CONTROLS:					
Consequence		Likelihood (of consequence)			Residual risk
Minor (2)		Unlikely (B)			Low risk
ACCEPTABLE LEVEL OF RISK DEMONSTRATED:					
Principles of ESD not compromised	External Context – objects or claims considered	Internal Context – VOGA HSE / procedures met	Other Requirements met	RR < High (RRII)	EPO(s) manage risk to acceptable level(s)
Relevant principles of ESD not compromised given proposed controls	N/A – no external objections or claims received	Yes – Risk managed in accordance with VOGA HSE policy and aligned to Performance Standards, Wandoo Marine Operations Manual [WNB-1000-YV-0001] and SPM Marine Facility Procedures [WPA-7000-YV-0002]. Potential spills to be managed in accordance with Wandoo Emergency Response Plan [VOG-2000-RD-0017]/Wandoo Field OSCP [WAN-2000-RD-0001].	Yes – Vessels and facility navigation lighting comply with relevant regulations	Yes – RRIV (Low)	Yes – EPOs specify no uncontrolled release of hydrocarbons. The following relevant overarching EPOs (Section 3.4) maintained providing control measures maintained: EPO-OP-01; EPO-OP-03; EPO-OP-04; EPO-OP-05; EPO-OP-06; EPO-OP-07; EPO-OP-08; EPO-OP-09; EPO-OP-10; EPO-OP-11; EPO-OP-12; EPO-OP-13; EPO-OP-16; EPO-OP-17; EPO-OP-18; EPO-OP-19; EPO-OP-20

6.19.2 Description of hazard

Loss of crude oil from the topsides production facilities may occur due to failure of process piping and vessels from over pressuring, human error during process break-ins, erosion and corrosion, process upsets and dropped objects.

A hydrocarbon release from the topsides process facilities is likely to continue for a significant duration depending on the size of the release, inventory and operating pressure. In the event of a leak detected by the fire and gas system, the ESD system will isolate the entire topsides process to minimise the inventory which could be released into the environment.

The maximum credible volume of crude oil that may be released due to a leak from the topsides facility is assumed to be the maximum volume of the largest vessel (100m³).

6.19.3 Impact assessment

6.19.3.1 Impact assessment criteria

Refer to Appendix 3 for the impact assessment criteria for a liquid hydrocarbon release.

6.19.3.2 Impacts

As the volume of a spill from the topsides is similar to the volume of a spill from the flow lines and risers, the impact assessment outlined in Section 6.23.3 remains relevant. A detailed description of the environmental impact of a hydrocarbon spill is provided in Section 6.2.3.

6.19.4 Oil spill response strategies (mitigation)

The oil spill response strategies considered feasible/not feasible for this spill are as per loss of crude oil from the export system as outlined in Section 6.3.6.1 (Table 6-20 and Table 6-21). The impacts of the oil spill response strategies are assessed in Section 6.5.

6.19.5 Risk ranking

Due to a maximum credible volume of topside spill of <100m³, and potential impacts, a consequence ranking of '2' was considered appropriate. The WNB FHA [WNB-3000-RH-0013] indicated that leaks from topsides equipment are in the order of one leak every three years; however, not all leaks will be of sufficient volume to result in a consequence of '2' and not all releases would make their way to the environment due to bunding and drainage provisions for liquid inventories. A likelihood ranking of 'B' was therefore considered appropriate. The residual risk ranking is Low risk (RRI).

6.19.6 ALARP and acceptability demonstration

6.19.6.1 Overview

The risk associated with a release of hydrocarbon from process topsides is inherent to the operation of a petroleum facility; however, these risks can be managed through implementation of effective control measures and associated performance monitoring.

The ALARP assessment has concluded that the risks are being managed to ALARP because:

- There are sufficient layers of protection in place for the current risk level; and
- Additional controls and alternative arrangements were evaluated and determined not to be practical due to the associated increase to other risks.

6.19.6.2 Existing controls

The hazard summary in Section 6.18 describes the controls for this hazard. The range of controls includes multiple independent, layers of protection, including:

- Design specification for pressure equipment and piping;
- Automated process shutdown on high pressure;
- Provision of pressure relief devices;
- Management controls for lifting over live equipment;
- The platform ESD system isolates hydrocarbon inventories; and
- Management of crane operations.

6.19.6.3 Spill response

VOGA's response strategies and procedures to reduce the volume of hydrocarbons spilt and reduce the environmental impact are outlined in the Wandoo Field OSCP [WAN-2000-RD-0001]. These response strategies are consistent with those outlined in the National Plan.

The application of VOGA's spill response strategies and procedures outlined above and in the Wandoo Field OSCP [WAN-2000-RD-0001] will reduce the risk of environmental impact from a loss of production fluids.

The spill response planning process is described in Section 7.9.2.2 and results in spill response which will best mitigate the environmental impacts of this hazard scenario.

A full explanation of the process to review response and capability requirements to support managing spill risks to ALARP is provided in Section 6.2.7.

6.19.6.4 Additional controls and alternative arrangements

VOGA carried out an assessment of alternative arrangements and additional controls to reduce risks. No credible alternative arrangement to the topsides processing was identified.

No additional controls were identified.

6.19.6.5 Conclusion

The ALARP assessment has concluded that the risks are being managed to ALARP because:

- The credible release volume from this event is small;
- There are sufficient layers of protection in place for the current risk level;
- In the unlikely event of spill from the topsides process, response strategies which match the hazard profile are defined in the Wandoo Field OSCP [WAN-2000-RD-0001] and will be

implemented to reduce the impact of the spill to the environment. The resources to implement the response has been determined and evaluated to ensure that the response strategies can be achieved; and

- Additional controls and alternative arrangements were not considered to be practical due to the associated increase to other risks.



6.20 Ancillary hydrocarbon or chemical spills

6.20.1 Hazard report

Table 6-62: Hazard report – Ancillary hydrocarbon or chemical spills

HAZARD:	Ancillary hydrocarbon or chemical spills						
EP risk no.:	EP-OP-R18						
Potential impacts:	Hydrocarbon or chemical loss up to 6m ³ to sea.						
PREVENTION:							
Activity/cause:	Existing management controls	Control type	Control hierarchy	Performance outcome	Performance standard	Measurement criteria	
Hydrocarbon (including diesel and lube oil) or chemical spill due to materials handling and storage.	Intermediate Bulk Containers (IBCs) are transferred to/from vessel using a chemical cradle.	Engineering	Reduction	Prevent the release of hydrocarbons and chemicals to the marine environment from incorrect material handling and storage.	Chemical cradles are certified and inspected for signs of damage.	Chemical cradle certification records.	
	IBCs, including lifting lugs, are certified.	Engineering	Reduction		IBCs are certified.	IBC certification records.	
	All chemicals are stored in bunded areas.	Engineering	Prevention		Bunds show no visible sign of damage or deterioration that would impair their ability to contain spills.	Visual inspection during operator walk-around.	
	All liquid waste containers will be closed to prevent loss overboard.	Engineering	Prevention		All liquid waste containers will be closed to prevent loss overboard.	Visual inspection during operator walk-around.	
	Hydrocarbon and chemical spill containment and clean-up material.		Engineering		Reduction	Spill kit contents are inspected and restocked after use.	Visual inspection during operator walk-around.
						Spill kits located near high risk areas for prompt spill response.	
Chemical assessment and selection process.	Administrative	Substitution	Chemical and hydrocarbon spills will be immediately cleaned up.	Incident reports indicate spills are cleaned up immediately.			
			Chemicals used in the production process that will be discharged to the marine environment are selected in accordance with the chemical assessment process.	Chemical changes/new chemical to have approved MoC. Assessment of existing chemicals is outlined in the review of current process chemicals.			
MITIGATION:							
	Existing management controls	Control type	Control hierarchy	Performance outcome	Performance standard	Measurement criteria	
	Wandoo Emergency Response Plan [VOG-2000-RD-0017].	Administrative	Mitigation	Mitigate the impact of hydrocarbon or chemicals discharge to sea.	Performance criteria as per WAN-WNAB-CP-ER-01 – Emergency preparedness, managements and response	Assurance criteria as per WAN-WNAB-CP-ER-01 - Emergency preparedness, managements and response.	
	Oil spill response arrangements	Administrative	Mitigation		Performance criteria, as per WAN-WNAB-CP-ER-02; WAN-WNAB-CP-ER-03, WNAB-CP-ER-01-05 and WNAB-CP-ER-01-06 (refer to Hazard EP-OP-R01 Table 6-2)	Assurance activities, as per WAN-WNAB-CP-ER-02; WAN-WNAB-CP-ER-03, WNAB-CP-ER-01-05 and WNAB-CP-ER-01-06	
INITIAL RISK WITH EXISTING CONTROLS:							
Consequence		Likelihood (of consequence)		Initial risk			
Incidental (1)		Unlikely (B)		Low risk			
ADDITIONAL CONTROLS/DEMONSTRATION OF ALARP - VOGA WORKSHOP:							
A low risk is defined as acceptable and typically do not require special attention outside of normal activities under the VOGA risk level action criteria. The following ALARP analysis provides assurance that all risk treatment options have been considered.							
Additional management controls			Assessment of option			Adopted/Not adopted	



INITIAL RISK WITH EXISTING CONTROLS:					
Increased bunding and drainage on WNA		Not feasible due to the requirement for rainwater drainage; and the fact that chemicals need to be portable, therefore higher bund walls prevent connection and access to chemical outlets and manifold.		Not adopted	
RESIDUAL RISK AFTER ADDITIONAL CONTROLS:					
Consequence		Likelihood (of consequence)		Residual risk	
Incidental (1)		Unlikely (B)		Low risk	
ACCEPTABLE LEVEL OF RISK DEMONSTRATED:					
Principles of ESD not compromised	External Context – objects or claims considered	Internal Context – VOGA HSE / procedures met	Other Requirements met	RR < High (RRII)	EPO(s) manage risk to acceptable level(s)
Relevant principles of ESD not compromised given proposed controls	N/A – no external objections or claims received	Yes – Risk managed as per HSE Policy and procedures. Potential spills to be managed in accordance with Wandoo Emergency Response Plan [VOG-2000-RD-0017]/Wandoo Field OSCP [WAN-2000-RD-0001].	N/A	Yes – RR = RRIV (Low)	Yes – EPOs specify no uncontrolled release of hydrocarbons. The following relevant overarching EPOs (Section 3.4) maintained providing control measures maintained: EPO-OP-01; EPO-OP-03; EPO-OP-04; EPO-OP-05; EPO-OP-06; EPO-OP-07; EPO-OP-08; EPO-OP-09; EPO-OP-10; EPO-OP-11; EPO-OP-12; EPO-OP-13; EPO-OP-16; EPO-OP-17; EPO-OP-18; EPO-OP-19; EPO-OP-20

6.20.2 Description of hazard

The Wandoo facilities use a variety of chemicals. Chemical spills may occur during handling and storage. Bulk chemicals are typically supplied by vessel in IBCs which are then lifted by crane onto the Facility. When transferring chemicals in this way, they are typically transferred within chemical cradles which will contain any spills if the primary containment fails. Any spills are likely to be small in nature, with the largest credible event being the dropping of an entire IBC.

Chemicals are stored in WNA and WNB in IBCs within dedicated bunds, hazardous chemical storage lockers or steel containers. Further details on the various process chemicals and their application are detailed in Section 6.7.

Spills originating from storage tanks on the Wandoo facilities are considered to be small in volume and contained within barriers inherent within the design of the Facility (i.e. bunding or enclosed spaces with drainage systems). The maximum credible spill for any liquid hazardous material at the Wandoo facilities is therefore considered to be <math><6\text{m}^3</math>.

Potential sources of minor chemical spills include:

- Water foaming agents used in firefighting (AFFF) may enter the sea if activated;
- Chemical spill due to materials handling and storage (1,450L chemical bulky);
- Other non-process chemicals such as paints and thinners, laboratory chemicals, medical wastes and cleaning agents. Spills of non-process chemicals may occur from incidents with storage, handling and transport. However, these are likely to be either of very minor quantity (usually less than 50L); and
- Sludge from equipment and vessel clean-out.

Minor hydrocarbon spills may also occur due to:

- Accidental release of hydraulic oil through leak/rupture of ROV umbilical. This is estimated to be less than 50L;
- Diesel or chemical spill due to materials handling and storage (1,450L chemical IBC, 205L diesel); and
- Hydrocarbon discharge due to removal and replacement of subsea equipment (80L) (residual hydrocarbons during hose, flow line and riser change-out).

6.20.3 Impact assessment

6.20.3.1 Sensitive receptors

Potential receptors in the water column (pelagic environment) are plankton, fish, marine mammals, marine reptiles and seabirds.

6.20.3.2 Impact assessment criteria

Refer to Appendix 3 for the impact assessment criteria for a liquid hydrocarbon release. Refer to Section 6.10.3.2 for the impact assessment criteria for a chemical release.

6.20.3.3 Impacts

Potential impacts associated with the accidental discharge of ancillary chemicals and small volumes of hydrocarbons are:

- Decline in water quality, including temporary increase in turbidity and contaminant levels;
- Toxicity effects to marine organisms; or
- Habitat impacts where the spill reaches sensitive marine areas such as coral reefs (or the shoreline).

6.20.3.4 Impact description

The impacts associated with the accidental discharge of liquid hazardous materials are related to the nature of the material spilled, the volume and its behaviour in the marine environment (sink/float/disperse etc.). In the event of a spill from Wandoo Facility to the marine environment the hazardous materials would be subjected to rapid dispersion and dilution by the open ocean water conditions and prevailing currents.

If hazardous materials are accidentally lost overboard, potential impacts will include a temporary and highly localised decline in water quality with limited potential for toxicity to marine fauna due to the temporary exposure and rapid dilution in the marine environment. Potential impacts are likely to be limited to the immediate vicinity and not affect overall population viability. A visible oil sheen on the water surface may also occur in the event of minor hydrocarbon spills. Importantly, these hydrocarbon compounds (lower molecular weight PAHs) are also volatile and will be rapidly be lost due to natural processes of evaporation during early stages of a spill. For this reason and given the minor volumes of hydrocarbons spilled, mortality of organisms due to lethal concentrations of dissolved hydrocarbons is expected to be rare, with contact with sensitive marine habitats (>40km) or the shoreline also predicted to be rare.

6.20.4 Risk ranking

Due to a maximum credible volume of 6m³, and potential impacts, a consequence ranking of '1' and a likelihood of 'B' was considered appropriate resulting in a residual risk ranking of Low risk (RRI).

6.20.5 ALARP and acceptability demonstration

The risk is considered to be ALARP and acceptable because:

- Exposure to this hazard is limited to transfers of chemicals between vessels and Facility, as on WNB, handling and storage of chemicals, waste oil, lube oil etc. is typically performed in areas that are bunded and drainage. Spills on WNB are unlikely to get into the sea due to the large deck area and drainage and bunding capacity;
- Improvements to WNA's drainage and bunding are cost prohibitive and not feasible in each instance due to:
 - Requirement for rainwater drainage; and
 - Chemicals need to be portable, therefore higher bund walls prevent connection and access to chemical outlets and manifold.

When transferring chemicals between vessel and platform, the lifting controls minimise the likelihood of dropping, and chemical cradles minimise the likelihood of leaking bulk chemicals into sea; and

As per the impact assessment, the impact area is localised, and the effect is temporary.



6.21 Physical presence of infrastructure

6.21.1 Hazard report

Table 6-63: Hazard report – Physical presence of infrastructure

HAZARD:	Physical presence of infrastructure					
EP risk no.:	EP-OP-R19					
Potential impacts:	Disturbance to marine fauna including marine mammals, reptiles and birds. Interaction with commercial and recreational fishing and shipping. Provision of an artificial habitat for benthic and pelagic organisms. Changes to visual amenity. Seabed scour (assessed in Section 6.22).					
PREVENTION:						
Activity/cause:	Existing management controls	Control type	Control hierarchy	Performance outcome	Performance standard	Measurement criteria
Presence of hydrocarbon production subsea and surface infrastructure consisting of subsea flowlines/ risers/ conductors, CGS and export system including CALM Buoy, mooring system, floating hose and unutilised subseas asset (Wandoo-1).	Emergency communications.	Engineering	Reduction	Stakeholders are identified and consulted on aspects of the Facility which may impact on stakeholder activities.	Performance criteria, as per WAN-WNAB-CE-ES-02-01 – UHF/VHF Radios. To ensure communication between CCR and the Emergency Response Team (at any location on the installations), personnel on WNA, personnel on CALM Buoy and external parties.	Assurance records, as per WAN-WNAB-CE-ES-02-01 – UHF/VHF Radios.
	Consultation/notification with relevant stakeholders including AusCoast/AMSA notification as required.	Administrative	Reduction		Records of communication with stakeholders will be stored.	Records of communication with stakeholders.
	For potential impact of disturbance to cetaceans and marine reptiles, no controls were identified as infrastructure is stationary and unlikely to have a major impact.	N/A	N/A		N/A	N/A
	For potential impact of provision of an artificial habitat for benthic and pelagic organisms, no controls were identified as no negative impact has been identified.	N/A	N/A	N/A	N/A	N/A
	For potential impact of changes to visual amenity, no controls were identified due to distance from shore.	N/A	N/A	N/A	N/A	N/A
Presence of topside hydrocarbon production facilities.	500m restriction zone surrounding the facility.	Administrative	Reduction	Wandoo facilities are publicly listed.	500m restriction zone surrounding the facility, as per the Wandoo Marine Operations Manual [WNB-1000-YV-0001].	Wandoo Marine Operations Checklist.
	Bird deterrents are used on WNA.	Engineering	Reduction	Reduce birds landing and roosting on WNA.	Bird deterrent shall be installed on the WNA and maintained in a functional state to minimise bird presence.	Maintenance records.



Activity/cause:	Existing management controls	Control type	Control hierarchy	Performance outcome	Performance standard	Measurement criteria
Temporary presence of subsea equipment associated with project, campaigns, surveys, etc.	Emergency communications.	Engineering	Reduction	Stakeholders are identified and consulted on aspects of the Facility which may impact on stakeholder activities.	Performance criteria, as per WAN-WNAB-CE-ES-02-01 – UHF/VHF Radios. To ensure communication between CCR and the Emergency Response Team (at any location on the installations), personnel on WNA, personnel on CALM Buoy and external parties.	Assurance records, as per WAN-WNAB-CE-ES-02-01 – UHF/VHF Radios.
	Consultation/notification with relevant stakeholders including AusCoast/AMSA notification as required.	Administrative	Reduction			

MITIGATION:						
Existing management controls	Control type	Control hierarchy	Performance outcome	Performance standard	Measurement criteria	
None identified.	N/A	N/A	N/A	N/A	N/A	N/A

INITIAL RISK WITH EXISTING CONTROLS:		
Consequence	Likelihood (of consequence)	Initial risk
Incidental (1)	Unlikely (B)	Low risk

ADDITIONAL CONTROLS/DEMONSTRATION OF ALARP - VOGA WORKSHOP:
 A low risk is defined as acceptable and typically do not require special attention outside of normal activities under the VOGA risk level action criteria. The following ALARP analysis provides assurance that all risk treatment options have been considered.

Additional management controls	Assessment of option	Adopted/not adopted
Alternative field development concept	Whilst decisions on field development concepts (e.g. using a Floating Production, Storage and Offloading (FPSO) facility with subsea wells, as opposed to the existing CGS structure) can be made during the design phase, they are not economically viable at this stage of the field lifecycle and grossly disproportionate to any environmental benefit.	Not adopted

RESIDUAL RISK AFTER ADDITIONAL CONTROLS:		
Consequence	Likelihood (of consequence)	Residual risk
Incidental (1)	Unlikely (B)	Low risk

ACCEPTABLE LEVEL OF RISK DEMONSTRATED:					
Principles of ESD not compromised	External Context – objects or claims considered	Internal Context – VOGA HSE / procedures met	Other Requirements met	RR < High (RRII)	EPO(s) manage risk to acceptable level(s)
Relevant principles of ESD not compromised given proposed controls	N/A – no external objections or claims received	Yes – Risk managed in accordance with VOGA HSE policy and procedures. Potential spills to be managed in accordance with Wandoo Emergency Response Plan [VOG-2000-RD-0017]/Wandoo Field OSCP [WAN-2000-RD-0001].	Yes - navigational hazards are controlled by existing AMSA requirements (i.e. Notice to Mariners; Australian Hydrographic Service notified of Wandoo Operational Areas).	Yes – RR = RRIV (Low)	Yes – EPOs specify that stakeholders are made aware of the activity, and birds are deterred from WNA. The following relevant overarching EPOs (Section 3.4) maintained providing control measures maintained: EPO-OP-01; EPO-OP-04; EPO-OP-05; EPO-OP-06; EPO-OP-07; EPO-OP-08; EPO-OP-09; EPO-OP-10; EPO-OP-11; EPO-OP-12; EPO-OP-13; EPO-OP-15

6.21.2 Description of hazard

The 'physical presence' refers to all aspects of the Wandoo facilities including subsea and surface facilities at WNA, WNB, Wandoo-1 well and the CALM Buoy and offloading system. It also includes the physical presence of vessels, tankers, ROVs and divers associated with Wandoo operations.

6.21.3 Impact assessment

6.21.3.1 Sensitive receptors

Marine habitats, fish, marine mammals, marine reptiles, seabirds and other users.

6.21.3.2 Impact assessment criteria

Impacts to the marine environment from the physical presence of offtake tankers, various support vessels, subsea equipment and divers.

6.21.3.3 Impacts

Potential impacts caused by the presence of subsea infrastructure include:

- Disturbance to marine fauna including pelagic organisms, marine mammals and marine reptiles;
- Provision of an artificial habitat for benthic and pelagic organisms;
- Interaction with commercial and recreational fishing, and shipping; and
- Seafloor scouring causing an increase in turbidity in the water column, resulting in localised smothering of benthos and a reduction in benthic productivity.

Potential impacts caused by the presence of surface infrastructure include:

- Disturbance to marine fauna including pelagic organisms, marine mammals, marine reptiles and birds;
- Interaction with commercial and recreational fishing, and shipping; and
- Changes to visual amenity.

Potential impacts caused by the presence of offtake tankers, various support vessels, subsea equipment and divers include:

- Disturbance to marine fauna including fish species, marine mammals and marine reptiles; and
- Interaction with commercial and recreational fishing and shipping.

6.21.3.4 Impact description

6.21.3.5 Disturbance to marine habitats (benthic), fish, marine mammals, marine reptiles and seabirds

The Operational Area is not known to support any critical breeding, feeding or calving areas for EPBC listed marine mammals (Section 4). However, the humpback whale may pass through the Operational Area during southward migration, and the Operational Area is within a migration BIA

for the humpback whale, and a distribution BIA for the pygmy blue whale (Section 4). Potential impacts associated with the presence of surface and subsea infrastructure on migrating whales in the area is considered minimal as the infrastructure is stationary.

Similarly, a potential impact to other marine species, including sea snakes and turtles which may also pass through the Operational Area, is considered minimal as the infrastructure is stationary.

Seabirds tend to aggregate around offshore production facilities in above average numbers, (Verhejen, 1985; Wiese *et al.*, 2001). This may be attributed to the fact that structures in deepwater environments provide an artificial habitat for benthic and pelagic organisms thus creating a food source for seabirds (Surman, 2002).

Based on the EPBC protected matters search only one EPBC listed threatened bird species; the southern giant petrel (*Macronectes giganteus*) may be found within the Operational Area (Section 4). Other migratory listed species which may or are likely to be found within the Operational Area are wetland species, therefore their presence is likely to be transitory. Reports from the facility has identified the presence of Brown Booby seabirds (EPBC Listed – Migratory) transiting through the Operational Area and roosting on the unmanned WNA.

Seafloor scouring and impacts to benthic habitat associated with the physical presence of infrastructure, is discussed below in Section 6.22.

The potential for vessel and helicopter collision with marine fauna (mammals and seabirds) and entrapment of seabirds is discussed in Section 6.18.

6.21.3.6 *Provision of an artificial habitat for benthic and pelagic organisms*

The physical presence of subsea infrastructure will act as artificial habitat or hard substrate, resulting in the settlement of marine organisms that would not otherwise be successful in colonising the area. Over time the colonisation of subsea infrastructure can lead to the development of a ‘fouling’ community, which subsequently provides predator or prey refuges, foraging resources for pelagic fish species and artificial reefs potentially supporting fish aggregations (Gallaway *et al.*, 1981).

The presence of seabed and floating structures may promote the presence of reef associated species such as cods and snappers. Similarly, near-surface infrastructure can support pelagic species that are commonly attracted to fixed and drifting surface structures in areas of open-ocean (Lindquist *et al.*, 2005).

Impacts associated with the provision of artificial habitat from subsea infrastructure are increased biological productivity and diversity, which can result in a localised influence on marine communities. Given the small scale of the artificial habitat created, the potential impacts are expected to be highly localised.

6.21.3.7 *Interaction with commercial and recreational fishing and shipping*

The physical presence of subsea and surface infrastructure, support vessels and tankers may pose a potential risk to commercial and recreational fishing in the area. Impacts include:

- Shipping interactions;
- Loss of fishing area; and

- Attraction of fish to the Facility due to the development of artificial habitat around subsea facilities and discharge of macerated food waste.

A 500m restriction zone exists around the Facility where fishing is not permitted. As there are no State or Commonwealth fisheries within the Operational Area, loss of access to the area will not impact on commercial fishing activities. Operational experience and consultation indicate that the Operational Area is not commonly used by recreational fishermen, hence the impact to recreational fishing is expected to be minimal.

The physical presence of the Facility may also interfere with commercial shipping traffic in the region. Impacts include:

- Loss of access to the area;
- Navigational hazards; and
- A collision risk.

Commercial shipping moves through the offshore waters enroute to or from the marine terminals at Thevenard, Barrow and Varanus Islands. Shipping using NWS waters include iron ore carriers, oil tankers and other vessels proceeding to or from the ports of Dampier, Port Walcott and Port Hedland; however, these are predominantly heading north from these ports. Large cargo vessels carrying freight bound or departing from Fremantle, transit along the WA coastline heading north and south in deeper waters. The Wandoo facilities are located more than 10km northwest of a designated shipping route. Movements of offshore international shipping activities were recorded for the NWS in 2010 (AMSA, 2012). Additionally, a 500m restriction zone exists around the Facility where shipping traffic is not permitted, as well as a cautionary zone (2.5 nautical miles around the Wandoo facilities).

The impacts in relation to navigational hazards are controlled by existing AMSA requirements (i.e. Notice to Mariners; Australian Hydrographic Service notified of Wandoo Operational Areas).

The impacts of collision of a vessel with the Facility are discussed in Section 6.4. The impact of a collision of a vessel with a tanker is discussed in Section 6.3.

6.21.3.8 Changes to visual amenity

Changes to visual amenity are considered to pose a negligible impact due to the distance of the platform from the shore.

6.21.4 Risk ranking

The Wandoo facility has been in operation since 1996. During this time there has been no reported complaints from stakeholders due to its physical presence. A consequence ranking of '1' (Incidental) and a likelihood of 'B' was considered appropriate resulting in a risk ranking of Low risk.

6.21.5 ALARP and acceptability demonstration

6.21.5.1 Utilised infrastructure

Physical infrastructure is integral to the production of hydrocarbons at the Wandoo Facility. A review of the risks and impacts to determine that the risks are acceptable and ALARP has assessed that:

- Environmental impacts associated with the physical presence of the Wandoo facilities may be reduced by utilising alternative field development concepts, e.g. using a Floating Production, Storage and Offloading (FPSO) facility with subsea wells, as opposed to the existing CGS structure. Whilst such decisions can be made during the design phase, they are not economically viable at this stage of the field lifecycle. Impact to the environment caused by this hazard is assessed by VOGA to be acceptable due to:
 - the relatively small footprint; and
 - alternative arrangements may not result in a smaller environmental impact. The potential impact of disturbance to marine fauna and seabirds is low, and is managed by controls to prevent the entrapment of birds.

The presence of both WNA and WNB has a very small spatial footprint and will continue to provide artificial habitat for both marine species and avifauna for its operational life. As the impacts are localised and the alternative associated with removing the facilities is not feasible, the risk from physical presence is considered acceptable and ALARP.

6.21.5.2 Unutilised Infrastructure: Wandoo-1

Vermilion's position on Wandoo-1 is that it will remain in place on the sea floor until end of field life when shallow and surface abandonment will take place and well head removed. This is due to:

- well is effectively abandoned from the reservoir, see Figure 2-4;
- further degradation of wellhead is unlikely to compromise successful completion of well abandonment;
- the relatively low risk and impact footprint of the wellhead on sea floor. Wandoo-1 impact is marginal in comparison to field infrastructure; and
- there are operational challenges and risks associated with conducting abandonment prior to end of field life of Wandoo A and WNA-WNB flowlines. Vermilion are of the position that it is a lower risk to abandon Wandoo-1 at the same time as Wandoo A and flowlines. Challenges of abandoning earlier include:
 - Working of boats in the vicinity of the WNA platform. Most jack-ups are arranged so that the workboat comes into the port side of the jack-up. If a jack-up is positioned at Wandoo-1 (see Figure 6-7), if the boat was to lose power or station keeping ability, it will drift straight in to the monopod. This can be mitigated somewhat by keeping Wandoo-A shut down for the duration of the campaign. However, the risk from damage to the Wandoo A platform (and therefore potentially the wells) and/or to the Wandoo A – B flowlines is significantly greater than the potential environmental risk of Wandoo 1 being in situ; due to the reservoir abandonment barrier and the shallow and surface suspension barriers being in place. Working a boat on the jack-ups starboard side introduces risks of

dropped objects potentially rupturing the subsea flowlines. Due to potential asset and environmental damage, preference is to conduct work when Wandoo A has reached end of its economic field life.

- Positioning the rig at Wandoo-1 would be challenging due to the proximity of infrastructure in place and field congestion limiting rig and associated vessel manoeuvrability. Rig positioning at Wandoo-1 has additional complexity when compared to positioning a rig adjacent to a platform and would need to be reviewed and agreed to by the drilling contractor and their marine underwriter.

The cost and timing associated with an abandonment make the investment required to remove the well earlier disproportional to the impact reduction. The budgetary estimate to plug and abandon Wandoo-1 is 14.1 days, assuming a spread rate of A\$750k/day equating to a total budget of A\$10.6MM (excluding rig move costs, production downtime and project cost contingencies). To manage engineering, planning and costs, if Wandoo-1 abandonment was conducted prior to Wandoo A abandonment, Vermilion would need to add this scope to the remaining well construction campaigns rather than a standalone activity.

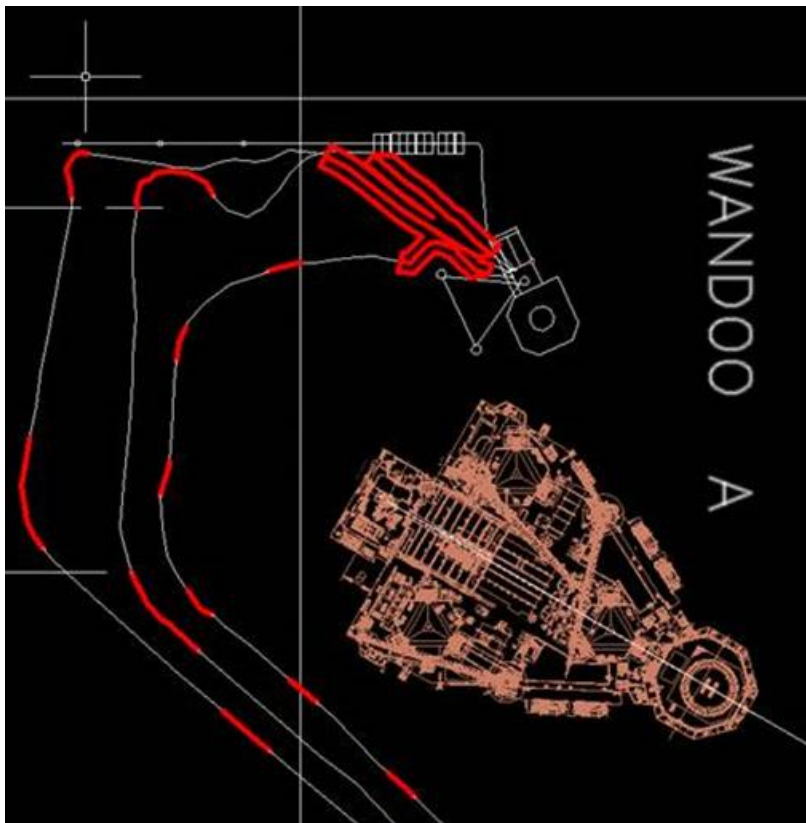

Figure 6-7 Location of MODU working on Wandoo-1

Due to planning, equipment design and lead times it is unlikely Wandoo-1 P&A activities would be ready for the next drilling campaign in 2022 and would need to wait 2-3 years for the following campaign. This means the difference of abandoning Wandoo-1 prior to end of field life is 5-7 years.

Given the well status, low impact to environment and operational risks, the cost and risks associated is disproportional to the benefit of removing the well 5-7 years earlier than it would be

removed at end of field. Based on this conclusion, the risk from physical presence and leaving well in place until end of field life is considered acceptable and ALARP.



6.22 Seabed disturbance

6.22.1 Hazard report

Table 6-64: Hazard report – Seabed disturbance

HAZARD:	Seabed disturbance					
EP risk no.:	EP-OP-R20					
Potential impacts:	Seabed scour. Increase in turbidity of the water column/reduction light penetration. Localised smothering of benthos. Localised reduction in benthic productivity.					
PREVENTION:						
Activity/cause:	Existing management controls	Control type	Control hierarchy	Performance outcome	Performance standard	Measurement criteria
Cleaning and marine growth removal. ROV and diving. Metocean monitoring. Installation of flowline stabilisation and freespan supports. Installation of scour protection. Anchoring and mooring. Removal and replacement of subsea assets; Wet storing.	There are no controls identified for these causes as there are no significant benthic habitats in the Permit Area, and impacts are local to the Facility.	N/A	N/A	N/A	N/A	N/A
Seabed scour around CGS.	Presence of scour protection around CGS.	Engineering	Reduction	Reduce seabed scour caused by Wandoo facilities and associated operations.	Performance criteria, as per WAN-WNAB-CE-PR-07-02.03 Substructure - scour control measures to prevent erosion and/or subsidence of sea bed around structures	Assurance records, as per WAN-WNAB-CE-PR-07-02.03 Substructure - scour control measures
MITIGATION:						
Existing management controls	Control type	Control hierarchy	Performance outcome	Performance standard	Measurement criteria	
None identified.	N/A	N/A	N/A	N/A	N/A	
INITIAL RISK WITH EXISTING CONTROLS:						
Consequence	Likelihood (of consequence)			Initial risk		
Incidental (1)	Possible (C)			Low risk		
ADDITIONAL CONTROLS/DEMONSTRATION OF ALARP - VOGA WORKSHOP:						
A low risk is defined as acceptable and typically do not require special attention outside of normal activities under the VOGA risk level action criteria. The following ALARP analysis provides assurance that all risk treatment options have been considered.						
Additional management controls	Assessment of option			Adopted/Not adopted		
Eliminate subsea inspection and maintenance activities.	The subsea activities that result in potential seabed disturbance are essential for maintaining the integrity of the subsea hydrocarbon system and cannot be avoided. The alternative of doing nothing would potentially compromise the integrity of the system, with increased technical risks and production failures, resulting in significant financial costs and potentially leading to increased risks of loss of containment, resulting in environmental impacts.			Not adopted		
RESIDUAL RISK AFTER ADDITIONAL CONTROLS:						
Consequence	Likelihood (of consequence)			Residual risk		
Incidental (1)	Possible (C)			Low risk		



ACCEPTABLE LEVEL OF RISK DEMONSTRATED:					
Principles of ESD not compromised	External Context – objects or claims considered	Internal Context – VOGA HSE / procedures met	Other Requirements met	RR < High (RRII)	EPO(s) manage risk to acceptable level(s)
Relevant principles of ESD not compromised given proposed controls	N/A – no external objections or claims received	Yes – Risk managed in accordance with VOGA HSE policy, SIMOPs Plan and Rig Move Plan. Potential spills to be managed in accordance with Wandoo Emergency Response Plan [VOG-2000-RD-0017]/Wandoo Field OSCP [WAN-2000-RD-0001].	Yes – MODU operations to be consistent with MODU Safety Case. AHTS vessels and MODU navigation lighting comply with SOLAS and the Navigation Act 2012. Notice to Mariners issues as required.	Yes – RR = RRIII (Medium)	Yes –The following relevant overarching EPOs (Section 3.4) maintained providing control measures maintained: EPO-OP-03; EPO-OP-04

6.22.2 Description of hazard

The physical presence of the Wandoo Facility subsea infrastructure may alter the seabed due to the creation of benthic habitats and sea floor scour along the seabed (Section 6.20.5).

The following infrequent activities may cause seabed disturbance:

- Cleaning and marine growth removal (Section 2.8.6);
- ROV and diving (Section 2.8.5);
- Metocean monitoring (Section 2.8.4);
- Installation of flowline stabilisation and freespan supports (Section 2.8.8);
- Installation of scour protection (Section 2.8.9);
- Anchoring and mooring (Section 2.8.13);
- Removal and replacement of subsea assets (Section 2.8); and
- Wet storing (Section 2.9.12).

These activities are discussed in the sections of the activity description outlined above.

6.22.3 Impact assessment

6.22.3.1 Sensitive receptors

Key marine habitats, benthic invertebrates.

6.22.3.2 Impact assessment criteria

Long-term impact to marine benthos from physical presence of the Wandoo Facility subsea infrastructure.

6.22.3.3 Impacts

Potential impacts to the seabed caused by the presence of subsea infrastructure and the activities identified above include:

- Seafloor scour;
- Localised smothering of benthos; and
- Localised reduction in benthic productivity.

6.22.3.4 Impact description

The physical presence of subsea infrastructure such as subsea flow lines and the CGS facility, combined with the action of altered current speed and direction around the infrastructure, can cause scour of soft sediments. At the Wandoo Facility, the seabed is characterised by soft unconsolidated sediments of no notable habitat value. Losses of soft substrata habitat due to seafloor scour represent a very small proportion of the widespread available habitat, and associated impacts to the benthic habitat or productivity are considered localised and minimal.

Air/water entrained sand/grit blasting of marine growth may result in the deposition of sand/grit and removed fouling material on the seabed via sedimentation. Deposition of material on the seabed may cause localised smothering of benthos and may locally alter the composition of the seabed sediments, due to the introduction of very small amounts of cleaning material (e.g. metals, paint chips). Although deposition of material may cause localised smothering of benthos, the seabed is characterised by soft unconsolidated sediments of no notable habitat value, hence associated impacts to benthic habitats are considered localised and minimal.

The deposition of sand and gravel-sized grit on the sea floor may change the composition of the seabed by shifting the grain size fraction of the surficial sediments more towards coarse sizes (coarse sand, gravel etc.) than silts that are usually present. This could potentially alter the benthic habitat in the region. However, over time the sand/grit would be expected to be gradually incorporated into the underlying sediments and the intensity of this effect would diminish. As the deposition of fouling material is temporary and localised in nature and the benthic habitat at Wandoo is similar to that found at other locations throughout the region (Section 4), potential impacts to benthic habitats due to this activity are considered minimal.

The installation of grout bags as part of flowline stabilisation/freespan supports or scour control may cause localised alteration to sediment composition and/or smothering of benthos. The installation of grout bags is expected to be undertaken within a short hence relatively rapid recovery/recolonisation of any benthic biota disturbed by settling cement material is expected to occur from adjacent areas following sedimentation. Cement chemicals are low toxicity, chemically inert and set in the marine environment (BP, 2010). The volumes of grout that may be released to the marine environment are low and localised. Given the temporary nature of the installation works, the non-toxic nature of the grout and the absence of significant benthic habitat and infauna in the region, potential impacts to benthic habitats due to this activity are considered minimal.

Anchoring will temporarily disturb areas of seabed corresponding to the footprint of the anchors and associated anchor chains. The disturbance may affect the benthic habitats involved and cause a reduction in benthic productivity. Given the localised nature of the disturbance and the lack of significant benthic habitat in the region, potential impacts from anchoring are considered minimal. The removal and replacement of subsea assets and wet storing may also cause temporary seabed disturbance due to the presence of divers and associated equipment in the area. As this activity is temporary in nature and the benthic habitat in the area is similar to that throughout the region, potential impacts to benthic habitat are considered localised and minimal.

6.22.4 Risk ranking

The seabed surrounding the Wandoo facilities are characterised by soft unconsolidated sediments of limited habitat value, hence associated impacts to benthic habitats are considered localised and minimal from seabed disturbance. A consequence ranking of '1' and a likelihood of 'C' was therefore considered appropriate resulting in a risk ranking of Low risk.

6.22.5 ALARP and acceptability demonstration

The activities associated with seabed disturbance are low in frequency and have a minor localised impact only. The potential impact to infauna is considered negligible and the risk from activities relating to seabed disturbance are considered ALARP and acceptable.



6.23 Liquid hydrocarbon release from flow lines and risers

6.23.1 Hazard report

Table 6-65: Hazard report – Liquid hydrocarbon release from flow lines and risers

HAZARD:	Liquid hydrocarbon release from flow lines and risers
EP risk no.:	EP-OP-R22
Potential impacts:	Liquid hydrocarbon release to environment, i.e. 0.8m ³ of oil to sea.

PREVENTION:

Activity/cause:	Existing management controls	Control type	Control hierarchy	Performance outcome	Performance standard	Measurement criteria
Loss of integrity of hydrocarbon containing equipment.	Flow lines and risers are designed and tested to maximum allowable operating pressure.	Engineering	Prevention	Prevent the release of hydrocarbon from flow lines and risers to the marine environment.	Flow lines and risers shall contain pressurised hydrocarbons.	Assurance records, as per WAN-WNAB-CP-PR-04-02 – Inspection, maintenance, monitoring and testing.
	Instrumentation initiators, alarms and final elements.	Engineering	Prevention		Performance criteria to ensure maintenance and inspection of instrumentation initiators, alarms and final elements relevant to hydrocarbon containing flow lines and risers, as per the following: <ul style="list-style-type: none"> Instrument Protective and Alarm Systems (WAN-WNAB-CE-DC-02) Integrated Control System (WAN-WNAB-CE-DC-07) Export Riser Shutdown Valves inspected and function tested 	Assurance records, as per following performance standards: <ul style="list-style-type: none"> Instrument Protective and Alarm Systems (WAN-WNAB-CE-DC-02) Integrated Control System (WAN-WNAB-CE-DC-07) Export Riser inspection and test records
	Asset integrity management.	Administrative	Prevention		Inspections and testing undertaken on flowlines and risers, as per WAN-WNAB-CP-PR-04-04 – Integrity Management. The integrity of critical elements shall be maintained at all times	Assurance records, as per WAN-WNAB-CP-PR-04-04 – Integrity Management.
	Process and procedures for managing process system.	Administrative	Reduction		Ensure that permitted operations are controlled and conducted in a safe manner.	Permit to work forms are completed in accordance with the Work Management Manual [WPA-7000-YG-0021].
Incorrect operation of valves during pigging operation.	Pigging procedure specifies correct valve sequence.	Administrative	Reduction	Prevent the release of hydrocarbons to the marine environment during pigging operation by ensuring that the system is depressurised prior to opening pig launcher and receiver.	Pigging procedure specifies correct valve sequence within the Wandoo Platform Operations Manual [VOG-7000-MN-0001].	Records of pigging activity in Pigging Report.
Structural failure of the platform due to fatigue/ aging asset.	Codes and standards as per facilities' Basis of Design.	Engineering	Reduction	Prevent the release of hydrocarbons from flow lines and risers to the marine environment due to structural collapse.	Performance criteria, as per WAN-WNAB-CE-PR-07-01.01 (Superstructure - Primary Structural Steel); WAN-WNAB-CE-PR-07-02.04 (Substructure - Corrosion control measures)	Assurance records, as per WAN-WNAB-CE-PR-07-01.01 (Superstructure - Primary Structural Steel); WAN-WNAB-CE-PR-07-02.04 (Substructure - Corrosion control measures)
Dropped objects/ swinging load onto riser or flow lines.	Lifting management procedures.	Administrative	Reduction	Maintain sufficient integrity so that loads or any lifting component does not fall in such a manner that it may	Crane operations managed as per the Crane Operations, Maintenance and Inspection Manual [WPA-7000-YM-0002].	Crane Operator Checklist completed prior to crane operation.



Activity/cause:	Existing management controls	Control type	Control hierarchy	Performance outcome	Performance standard	Measurement criteria
	Crane maintenance.	Engineering	Prevention	cause, or contribute, to a release of hydrocarbon to the marine environment.	Performance criteria, as per WAN-WNAB-CE-PR-05-01 - Platform Cranes and Man-riding Winch. Safely performs lifting operations to prevent dropped objects or swinging loads.	Assurance records, as per WAN-WNAB-CE-PR-05-01 - Platform Cranes and Man-riding Winch.
Passing vessel collision with riser	Emergency communications.	Engineering	Prevention	Prevent the release of hydrocarbons from flow lines and risers to the marine environment due to vessel collision.	Performance criteria, as per WAN-WNAB-CE-ES-02-01 – UHF/VHF Radios. To ensure communication between CCR and the Emergency Response Team (at any location on the installations), personnel on WNA, personnel on CALM Buoy and external parties.	Assurance records, as per WAN-WNAB-CE-ES-02-01 – UHF/VHF Radios.
	Navigation aids.	Engineering	Reduction		Performance criteria, as per: <ul style="list-style-type: none"> WAN-WNAB-CE-PR-06.01 - Navigation Lights. To provide visual indication to marine vessels of the position of the installation (WNA & WNB) so that they may take timely action to avoid the area. WAN-WNAB-CE-PR-06.02 - Fog Horn. To provide audible indication to marine vessels of the position of each fixed installation (WNA and WNB) so that they may take timely action to avoid the area. 	Assurance records, as per: <ul style="list-style-type: none"> WAN-WNAB-CE-PR-06.01 - Navigation Lights. WAN-WNAB-CE-PR-06.02 - Fog Horn.
	Platform location published on Marine Charts.	Administrative	Reduction		Wandoo facilities are marked on marine charts and any changes to Wandoo facilities notified via Notices to Mariners.	Records to confirm that Wandoo facilities are on chart and applicable Notice to Mariners.
	500m restriction zone surrounding the facility.	Administrative	Reduction		500m restriction zone surrounding the facility, as per the Wandoo Marine Operations Manual [WNB-1000-YV-0001].	Wandoo Marine Operations Checklist.
Attending vessel collision with riser	Station keeping requirements for vessels.	Administrative	Reduction	Dynamic positioning requirements, as per Section 9 of the Wandoo Marine Operations Manual [WNB-1000-YV-0001].	Wandoo Marine Operations Checklist.	
	Vessel operations restricted in adverse weather.	Administrative	Reduction	Vessel operations restricted in adverse weather, as per the Wandoo Marine Operations Manual [WNB-1000-YV-0001].	Wandoo Marine Operations Checklist.	
	Permission required for field entry, CALM Buoy approach, mooring-up and departure.	Administrative	Reduction	Vessels shall comply with permissioning protocols for vessels entering the field, CALM Buoy approach, mooring-up and departure, as per the Wandoo Marine Operations Manual [WNB-1000-YV-0001].	Wandoo Marine Operations Checklist.	
Tanker station keeping failure.	Hawser is fit for purpose.	Engineering	Reduction	Hawser, chains and shackles shall be checked for mechanical damage and wear prior to offtake, as per the SPM Marine Facility Procedures [WPA-7000-YV-0002].	Offtake Maintenance Report.	
	Structural integrity of CALM Buoy mooring.	Administrative	Reduction	Performance criteria, ensuring inspection of CALM buoy mooring as per <ul style="list-style-type: none"> WAN-WNB-CE-PR-07-03. 01 - Mooring System - CALM Buoy, including mooring arm WAN-WNB-CE-PR-07-03. 02 - Mooring System - Chains and Anchors 	Assurance records, as per <ul style="list-style-type: none"> WAN-WNB-CE-PR-07-03. 01 - Mooring System - CALM Buoy, including mooring arm WAN-WNB-CE-PR-07-03. 02 - Mooring System - Chains and Anchors 	



Activity/cause:	Existing management controls	Control type	Control hierarchy	Performance outcome	Performance standard	Measurement criteria
	Weather restrictions apply to offtake activities.	Administrative	Reduction		Offtake operations shall be restricted in adverse weather, as per the SPM Marine Facility Procedures [WPA-7000-YV-0002].	Offtake Maintenance Report.
	Wandoo Mooring Master on board tanker during offtake.	Administrative	Reduction		Wandoo Mooring Master meets minimum competency standard as per contract	Training records confirmed for Mooring Master
	Static tow by support vessel to control tanker position	Engineering	Reduction		A support vessel shall be present to assist with each offtake operation and must remain connected to the Tanker, providing static tow, throughout the offtake as per as per the SPM Marine Facility Procedures [WPA-7000-YV-0002].	Safety Checklist

MITIGATION:						
Existing management controls	Control type	Control hierarchy	Performance outcome	Performance standard	Measurement criteria	
Platform ESD will close riser shutdown valve.	Engineering	Mitigation	Mitigate the impact of a hydrocarbon release to the marine environment from flow lines or risers.	Refer to instrumentation initiators, alarms and final elements control and performance criteria in Prevention section of hazard table above.	Assurance records	
Wandoo Emergency Response Plan [VOG-2000-RD-0017].	Administrative	Mitigation		Performance criteria as per WAN-WNAB-CP-ER-01 – Emergency preparedness, managements and response	Assurance criteria as per WAN-WNAB-CP-ER-01 - Emergency preparedness, managements and response.	
Oil spill response arrangements	Administrative	Mitigation		Performance criteria, as per WAN-WNAB-CP-ER-02; WAN-WNAB-CP-ER-03, WNAB-CP-ER-01-05 and WNAB-CP-ER-01-06 (refer to Hazard EP-OP-R01 Table 6-2)	Assurance activities, as per WAN-WNAB-CP-ER-02; WAN-WNAB-CP-ER-03, WNAB-CP-ER-01-05 and WNAB-CP-ER-01-06	

INITIAL RISK WITH EXISTING CONTROLS:		
Consequence	Likelihood (of consequence)	Initial risk
Incidental (1)	Unlikely (B)	Low risk

ADDITIONAL CONTROLS/DEMONSTRATION OF ALARP - VOGA WORKSHOP:		
Additional management controls	Assessment of option	Adopted/Not adopted
A low risk is defined as acceptable and typically do not require special attention outside of normal activities under the VOGA risk level action criteria. The following ALARP analysis provides assurance that all risk treatment options have been considered.		
Refer to Section 6.2.7 for oil spill response ALARP evaluation tables.		
Protection of flow lines (in areas which can be impacted by dropped objects)	This item was not considered necessary with no risk mitigation potential as the crane has limited reach over the flow lines.	Not adopted
Standby vessel in situ 24 hrs/day: To monitor the PSZ and be equipped with an automatic identification system to aid in its detection at sea, and radar to aid in the detection of approaching third-party vessels.	Reduces risk of vessel collision to riser and subsequent unplanned release of hydrocarbons. High cost associated with contracting standby vessel. Costs of operating navigational equipment. The costs associated with having a vessel on location 24/7 are considered disproportionate to the environmental benefit gained, particularly given the infrastructure are marked on charts and navigational aids are present.	Not adopted

RESIDUAL RISK AFTER ADDITIONAL CONTROLS:		
Consequence	Likelihood (of consequence)	Residual risk
Incidental (1)	Unlikely (B)	Low risk



ACCEPTABLE LEVEL OF RISK DEMONSTRATED:					
Principles of ESD not compromised	External Context – objects or claims considered	Internal Context – VOGA HSE / procedures met	Other Requirements met	RR < High (RRII)	EPO(s) manage risk to acceptable level(s)
Relevant principles of ESD not compromised given proposed controls	N/A – no external objections or claims received	Yes – Risk managed in accordance with VOGA HSE policy and procedures. Potential spills to be managed in accordance with Wandoo Emergency Response Plan [VOG-2000-RD-0017]/Wandoo Field OSCP [WAN-2000-RD-0001].	Yes – navigation aids in compliance with relevant regulations	Yes – RR = RRIII (Medium)	Yes – EPOs specify no uncontrolled release of hydrocarbons. The following relevant overarching EPOs (Section 3.4) maintained providing control measures maintained: EPO-OP-01; EPO-OP-03; EPO-OP-04; EPO-OP-05; EPO-OP-06; EPO-OP-07; EPO-OP-08; EPO-OP-09; EPO-OP-10; EPO-OP-11; EPO-OP-12; EPO-OP-13; EPO-OP-16; EPO-OP-17; EPO-OP-18; EPO-OP-19; EPO-OP-20

6.23.2 Description of hazard

Well fluids from WNA are supplied to WNB via a production riser and flow line. After the oil is being processed, the oil is then stored in the CGS before being exported to a tanker via an export riser and flowline from WNB.

Several causes which could lead to loss of liquid hydrocarbon from the risers and flow lines in the Wandoo Field have been identified, and these include:

- Corrosion/erosion;
- Human error during pigging;
- Structural failure of platform due to fatigue/aging asset;
- Vessel collision with riser; and
- Dropped object/swinging load.

The maximum credible volume of crude oil that may be released due to a spill from the production risers and flow lines is 0.8m³ of oil. This is based on the value used in the existing facility WNB Credible Fire and Explosion Analysis (CFEA). The value considers the oil fraction in the well fluids and has recently been demonstrated to be significantly overestimated of the actual oil volume in the flow line.

Several safeguards are in place such as the RSDV which will close in the event of an emergency or leak detected as part of the ESD logic. This will isolate the risers and flow lines, minimising the hydrocarbon inventory that could be released into the environment. Risers on WNB are located at the northeast corner in-board on Shaft 1, to maximise their distance from the 'safe' end of the Facility, and to minimise the risk of damage in the event of a ship collision.

6.23.3 Impact assessment

6.23.3.1 Impact assessment criteria

Refer to Appendix 3 for the impact assessment criteria for a liquid hydrocarbon release.

6.23.3.2 Impact description

This spill scenario was not modelled, as the risks associated with these events were considered ALARP, with potential impacts resulting from a spill from flow lines and risers being much lower than those resulting from other spill scenarios, such as a Wandoo Crude tanker cell spill (Section 6.3.3.3).

Due to the small potential spill volume, any impacts are anticipated to be highly localised and short term in nature. The closest sensitive habitats to the Operational Area are located in the Dampier Archipelago and Montebello Islands, 40km and 90km from the Operational Area respectively. As a significantly larger instantaneous spill of 10,000m³ has only a low probability of impacting these habitats (Section 6.3.3.3), it is considered highly unlikely that crude from the above spill scenarios would reach these habitats.

Reversible, short term impacts could occur on fauna in the immediate vicinity of the spill, including plankton, fish, marine mammals, reptiles and seabirds. A detailed description of the potential environmental impacts of a hydrocarbon spill is provided in Section 6.2.3.

6.23.4 Oil spill response strategies (mitigation)

The oil spill response strategies considered feasible/not feasible for this spill are as per loss of crude oil from the export system outlined above Section 6.3.6.1 (Table 6-20 and Table 6-21). The impacts of the oil spill response strategies are assessed in Section 6.5.

6.23.5 Risk ranking

The unlikely maximum credible volume of crude oil that may be released due to a spill from the production risers and flow lines is 0.8m³ of oil, and a consequence ranking of '1' (Incidental) considered appropriate based on the potential impacts.

Release frequency associated with the risers has been identified as 5.46E-04 (Wandoo safety Case) and a likelihood of 'B' considered appropriate resulting in a residual risk ranking of Low (RRI).

6.23.6 ALARP demonstration

6.23.6.1 Overview

The risk associated with a release of hydrocarbon from flow lines and risers is inherent to the operation of an offshore petroleum facility; however, these risks can be managed through implementation of effective control measures and associated performance monitoring. The ALARP assessment has concluded that the risks are being managed to ALARP because:

- There are sufficient layers of protection in place for the current risk level; and
- Additional controls and alternative arrangements were not considered to be practical due to the associated increase to other risks.

6.23.6.2 Existing controls

The hazard summary in Section 6.23.2 describes the controls for this hazard. The range of controls include multiple, independent layers of protection, including:

- Design of flow line, risers and platform to ensure required integrity;
- Corrosion prevention;
- Pigging management controls;
- Communication and navigational aids to alert vessels to Facility position; and
- The ESD system will close the RSDV to minimise the hydrocarbon available for release.

6.23.6.3 Spill response

VOGA's response strategies and procedures to reduce the volume of hydrocarbons spilt and reduce the environmental impact are outlined in the Wandoo Field OSCP [WAN-2000-RD-0001]. These response strategies are consistent with those outlined in the National Plan.

The application of VOGA's spill response strategies and procedures outlined above and in the Wandoo Field OSCP [WAN-2000-RD-0001] will reduce the risk of environmental impact from a loss of production fluids.

The spill response planning process is described in Section 7.9.2.2 and results in spill response which will best mitigate the environmental impacts of this hazard scenario.

A full explanation of the process to review response and capability requirements to support managing spill risks to ALARP is provided in Section 6.2.7.

6.23.6.4 Additional controls and alternative arrangements

VOGA carried out an assessment of alternative arrangements and additional controls to reduce risks:

- Pigging processes outlined in the Platform Operations Manual were reviewed and improvements to reduce hydrocarbon leak potential are being made in 2014;
- Protection of flow lines (in areas which can be impacted by dropped objects). This item is not considered necessary as the crane has limited reach over the flow lines.
- Standby vessel considered grossly disproportionate to potential environmental benefit and controls already in place.

No additional controls were identified.

6.23.6.5 Conclusion

The ALARP assessment has concluded that the risks are being managed to ALARP because:

- There are sufficient layers of protection in place for the current risk level;
- In the unlikely event of spill from the risers or flow lines, response strategies which match the hazard profile are defined in the Wandoo Field OSCP [WAN-2000-RD-0001] and will be implemented to reduce the impact of the spill to the environment. The resources to implement the response have been determined and evaluated to ensure that the response strategies can be achieved; and
- Additional controls and alternative arrangements were not considered to be practical due to the associated increase to other risks.

6.23.7 Acceptability demonstration

These risks are considered to be acceptable due to:

- There being sufficient layers of protection in place to minimise leaks from flow lines within the Wandoo field; and
- Should a leak from the flow line occur, the level of environmental impact is expected to be low;
- Ongoing stakeholder consultation undertaken for this Wandoo Facility EP did not generate any feedback regarding concerns due to spills from the subsea system;
- With the preventative and mitigative controls in place, the conservation of biological diversity and ecological integrity shall be maintained; and

- In the event of a hydrocarbon spill, the activities, and the proposed performance management measures, meet the requirements of internal VOGA procedures that have been developed in accordance with relevant environmental legislation.

7. Implementation strategy

7.1 Overview

The primary goals of VOGA's Wandoo Facility EP implementation strategy is to direct, review and manage operations activities so that environmental impacts and risks are continually being managed to ALARP, and to ensure that performance outcomes and standards are being met over the operational life of the project.

The VOGA HSE Management System (HSE MS) provides the procedures and practices that will be followed to ensure environmental risks of operations are reduced to ALARP.

The following approaches are used to ensure VOGA's HSE MS, practices and procedures are implemented:

- Activities will be undertaken in accordance with VOGA's HSE MS (Section 7.2);
- Activities will be undertaken in accordance with VOGA's HSE Policy (Section 7.2.3);
- Activities will be assessed in accordance with the VOGA Risk Management Manual [VOG-2000-MN-0001] (Section 5);
- Contractors are managed (Section 7.3);
- Roles and responsibilities are outlined (Section 7.4);
- Training and competency is outlined (Section 7.5);
- There is ongoing hazard identification and evaluation (Section 7.13);
- Performance outcomes, standards and measurement criteria are implemented (Section 7.6);
- Non-conformances and changes are appropriately managed (Section 7.7);
- Opportunities for continual improvement are identified (Section 7.8.4).
- ERPs are in place (Section 7.9);
- Oil pollution response arrangements are in place and regularly tested (Section 7.10);
- Chemicals used in offshore applications are appropriately managed (Section 7.11);
- A biofouling risk assessment process is in place and implemented (Section 7.12);
- Monitoring and review is undertaken, including inspection and audit plan developed and implemented (Section 7.13); and
- Environmental performance reporting is undertaken (Section 8)

7.2 HSE management system

7.2.1 Overview

The VOGA HSE MS provides the procedures and practices that will be followed to ensure that the environmental risks associated with its activities are reduced to ALARP.

The HSE MS has been developed to be consistent with the requirements of the following standards:

- ISO 14001: Environmental Management System;
- OHSAS 18002:2000 Occupational Health & Safety Management Systems (an international standard equivalent to AS/NZS 4801); and
- API 9100 Model Environmental, Health and Safety Management System.

HSE MS is also consistent with AS/NZS 4360:2004 Risk Management although it has not been developed specifically to meet that standard.

7.2.2 Structure

The following section describes the structure of the HSE MS, how it integrates top level management through to operational activities on the facilities, and how the elements of the HSE MS are linked in a logical manner to all activities. The overall HSE MS documentation hierarchy is illustrated in Figure 7-1

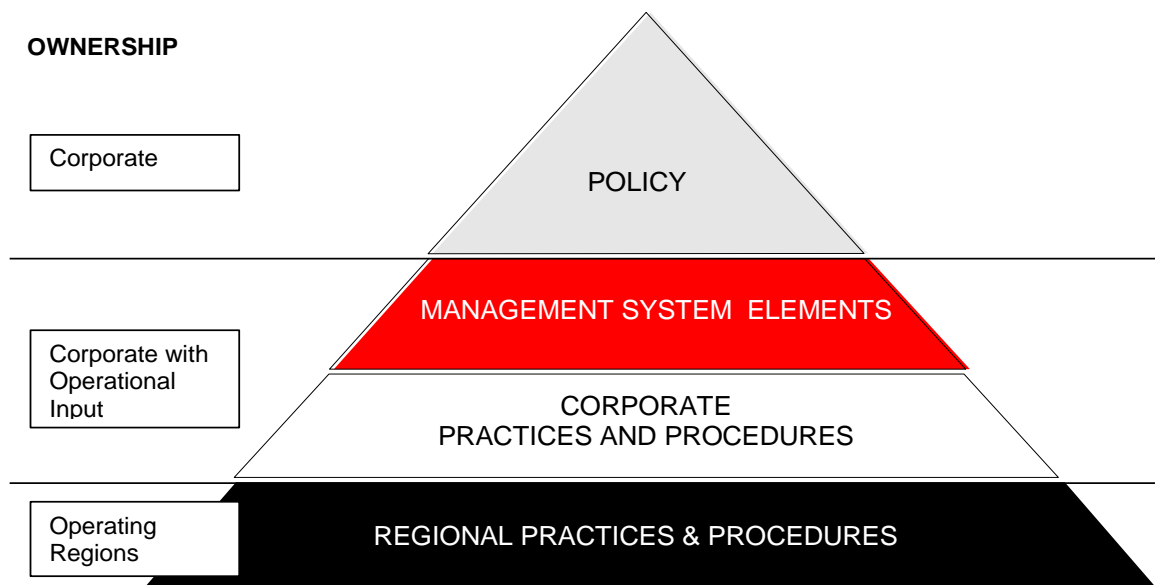

Figure 7-1 HSE MS Framework

7.2.3 Policy

The VOGA HSE Policy applies to all VOGA activities. The written policy statement provides an overall commitment in terms of key principles, for managing health, safety and the environment. The Policy sets the overall HSE intentions of the organisation and contains a commitment to

continuous improvement. The Policy is the starting point for setting VOGA's HSE objectives and targets. VOGA's HSE Policy is contained in Appendix 2

7.2.4 Contents

VOGA has developed an HSE MS that consists of three phases as follows:

- Phase 1: Plan
- Phase 2: Implement
- Phase 3: Check and correct

As outlined in Figure 7-2, the three-phase structure provides a continual improvement feedback cycle consistent with management system concepts that underlie the various standards. Each phase has one or more component element, and each element has multiple expectations.

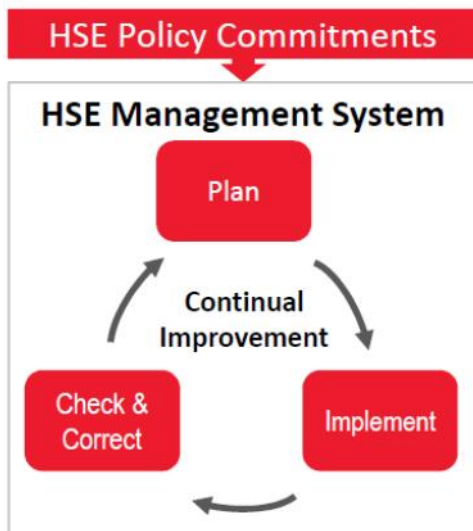

Figure 7-2 Outline of HSE MS Process – Plan-Implement-Check and Correct

The HSE MS is structured into 12 elements as outlined in Table 7-1. Each element has been developed within the overall three-phase HSE MS process (Plan-Implement-Check and Correct). As such, each element connects to one or more of the other elements within the overall continual improvement cycle.

Table 7-1 HSE MS Elements

Phase	HSE MS Elements	Objectives
Plan	Element 1: Management, Leadership and Policy	Management provides vision, resources and the environment for HSE MS success. All employees understand and are held accountable for the success of HSE MS. Performance excellence in HSE is recognised as a priority and prerequisite to successful business results.
	Element 2: Corporate and Social Responsibility and Communication with Stakeholders	VOGA is committed to protecting health, safety and the environment, and reducing and managing the HSE risks associated with its operations. In doing so, it is important that VOGA commit to an open dialogue with employees, the communities in which they operate, and other relevant stakeholders with respect to HSE issues associated with VOGA operations.
	Element 3: Risk Management	VOGA will ensure that risks are identified and managed to minimise the potential for incidents and liabilities.
	Element 4: MoC	Risks associated with change to personnel, organisations, procedures, practices, designs, facilities and regulatory requirements are identified, evaluated and managed.
Implement	Element 5: Training and Competency	Personnel are required to have the necessary skills and competencies to carry out their responsibilities in a safe and effective manner. Managers will ensure all employees have the appropriate skills and knowledge and will provide training where necessary.
	Element 6: Operations and Maintenance	HSE practices and procedures are necessary for the construction and operation of each asset. Practices and procedures are prescriptive “how to’s” of job tasks. The purpose of this element is to identify the requirements for practices and procedures necessary for each business/facility to ensure employees, contractors, the general public and the environment are protected from accidents/incidents.
	Element 7: Contractor Management and Procurement	It is important that controls are in place to ensure that activities undertaken by contractors, vendors and service providers are carried out in an efficient, safe and environmentally responsible manner.
	Element 8: Emergency Preparedness Management and Response	All operating areas have the necessary ERPs, skills and equipment to respond quickly to any emergency associated with our operations.
	Element 9: Incident Management	Reporting, investigating, analysing, follow-up and sharing information from incidents (and near misses) are used to minimise future occurrences.
	Element 10: Security Management	VOGA protects its people and assets from security risks and threats.
	Element 11: Documentation and Records	Operating regions ensure relevant documentation and records required to meet regulatory and VOGA business entity internal performance requirements, are maintained, organised and accessible.
Check and correct	Element 12: Performance Assessment	Continual improvement is assured through regular assessments, audits and reports to management.

7.2.5 Review of the HSE MS

To ensure ongoing effectiveness and continual improvement of the HSE MS, VOGA and Vermilion Energy Inc. periodically review the elements of the HSE MS, including Element 12. This review process is intended to provide a mechanism for making changes to the HSE MS as necessary to achieve the organisational goals and meet the expectations of stakeholders. VOGA and Vermilion Energy Inc. Senior Management review VOGA HSE MS performance in order to achieve the following:

- Determine its continuing suitability, adequacy and effectiveness;
- Address possible needs for changes to the HSE Policy, procedures, objectives, targets and other elements of the management system; and
- Identify opportunities for continual improvement.

VOGA and Vermilion Energy Inc. Senior Management review the effectiveness of the VOGA management system and provide formal feedback to assure continual improvement through:

- An annual review of VOGA HSE MS performance;
- Monthly review of HSE Key Performance Indicators (KPIs);
- Incident reports (as required); and
- Audit reports (as required).

7.3 Contractor management

Many of the risks associated with the Wandoo Facility operations, maintenance and inspection and project activities are embedded in processes that are controlled by service or contractor organisations and contractor personnel. VOGA selects contractors and service providers in accordance with the VOGA Contractor and Vendor Selection and Management Manual [VOG-1000-MN-0001]. Each high-risk contractor is assessed to ensure they meet a minimum level of service capability, inclusive of management systems to ensure acceptable QHSE performance and personnel competency. If shortcomings are identified during the assessment process, they are reviewed with the contractor in question and, where necessary, management processes are applied to address critical areas of concern.

When carrying out activities on a VOGA-contracted facility, all contractors are required to work in accordance with the Wandoo Facility Safety Case Revisions for which compliance with the HSE MS and this EP are fundamental requirements.

VOGA requires that:

- the specifications of equipment or materials that have potential QHSE impacts are reviewed to verify suitability for the intended use and to mitigate against the introduction of additional risks;
- all requisitions for materials and equipment specify, where relevant, appropriate certification and inspection requirements; and
- induction programs are in place to ensure that personnel are aware of the management systems in use during the operations and to communicate any major HSE risks and their management strategies.

VOGA commissions pre-mobilisation inspections to ensure their compliance with applicable standards and contractor management systems and to confirm that they can operate in a safe and environmentally responsible manner. Further detail on inspections and audits undertaken is provided in Section 7.13.

7.4 Key roles and responsibilities

The key roles and responsibilities for the implementation, management and review of the EP have been established. A description of the roles and responsibilities of the key positions are outlined in Table 7-2 in relation to VOGA's HSE MS and HSE performance, which includes this EP and environmental performance.

All VOGA personnel have a duty to carry out their work in accordance with the VOGA HSE MS to effectively manage HSE risks. Responsibility for HSE lies at every level of the organisation, with the ultimate responsibility resting with the managers (Operations Manager, Engineering Manager, and Finance Manager), and ultimate accountability resting with the VOGA Managing Director.

Table 7-2: EP key roles and responsibilities

Role	Responsibilities
VOGA Managing Director	<ul style="list-style-type: none"> Review and approve EP and OSCP. Ensures that appropriate resource and competence levels are available to deliver safe, efficient and effective operations within VOGA's organisation. Ensures overall compliance with the VOGA HSE MS. Ensures overall compliance with the EP and OSCP with advice from the HSES Advisor. Responsible for facilitating an emergency response strategy in the event of an incident.
Operations Manager	<ul style="list-style-type: none"> Setting expectations and providing resources for successful implementation of the HSE MS, which include this EP. Reviewing the HSE performance to ensure it meets company objectives and expectations. Review performance against environment performance standards outlined in this EP. Ensuring all individuals for whom they are responsible are adequately skilled for tasks they are expected to perform, and work processes used are fit for purpose. Ensuring compliance with EP. Involving all personnel in the relevant activity-specific HSE plans for Operations/Projects/Well Construction. Effective review and corrective action tracking in place for all incidents, defects, hazards, inadequacies of procedures and suggested improvements that are escalated. Ensures that all personnel (including contractors) are aware of their responsibilities in regard to ensuring compliance with the Commitments Register and that processes are in place to meet them. Oversees all aspects of contracting, procurement, logistics, QHSE, planning, design, execution and review for maintenance, inspection and project activities.

Role	Responsibilities
	<ul style="list-style-type: none"> • Ensures appropriate resources and competence levels are available to deliver safe, efficient and effective operations, maintenance, inspection and project activities. • Ensures that effective emergency response systems are in place for operations. • Ensures that VOGA’s stated obligations are met during all operations, maintenance and inspection and project activities. • Ensures that the policies and procedures of contractor companies are consistent with the VOGA Management Systems. • Ensures activities specified in the Commitments Register are appropriately closed out. • Ensures that all significant changes that may increase risk to environment are managed via the MOC Process.
Engineering Manager	<ul style="list-style-type: none"> • Fulfilling emergency response and crisis management roles as defined in the Wandoo ERP and Wandoo Field OSCP. • Ensures that all significant changes that may increase risk to environment are managed via the MOC Process. • Ensures that VOGA’s stated obligations are met during all operations, maintenance and inspection and project activities.
Field Superintendent	<ul style="list-style-type: none"> • Ensuring compliance with VOGA HSE MS, EP and Wandoo Field OSCP. • Leads/participates in audits and inspections. • Ensures that environmental incidents are: <ul style="list-style-type: none"> ○ reported to statutory authorities ○ reported as per Event Management Manual requirements ○ also ensures that incident investigations are conducted, and corrective actions are completed. • Ensures drills and exercises for emergency response are completed. • Ensures corrective actions arising from audits and emergency response drills are complete. • Manages coordinating and controlling of all field operational activities (production, maintenance, procurement and logistics). • Acts as Permit to Work custodian and ensures that the potential impact of a SIMOPS environment is considered during the preparations for all activities. • Provides leadership and stewardship for environment protection. • Meets all operational and HSE Key Performance Indicators (KPIs) as set by VOGA. • Ensuring or establishing adequate HSE management and action plans existing for every activity and site for which they are responsible. • Appropriately involving employees and HSE committees in the development of HSE management plans. • The development, review and close out of corrective actions in response to lessons learnt, incidents, defects, hazards, inadequacies of procedures and suggested improvements reported within their area of responsibility. • Providing appropriate resources for compliance with HSE laws and management of HSE risks in accordance with their delegated authorities. • The escalation of issues to the next level of management when the issue impacts other areas.



Role	Responsibilities
	<ul style="list-style-type: none"> • Fulfilling emergency response and crisis management roles as defined in the Wandoo ERP and Wandoo Field OSCP. • NOTE: Upon activation of the Wandoo ERP, the on-site Field Superintendent has authority. Outside of an emergency situation, the Field Superintendent works in accordance of HSE-MS requirements and seeks approvals to for changes in accordance with MoC processes.
Logistics Coordinator	<ul style="list-style-type: none"> • Ensures all VOGA purchased/supplied materials and equipment for use in Wandoo operations meet VOGA standards prior to acceptance and dispatch. • Maintains records of independent review and inspection activities associated with the purchase/supply of materials and equipment. • Ensures appropriate logistical resources are available in the field and in the supply base to deliver safe, efficient and effective operations. • Coordinates the efficient unloading of materials and unloading of waste in accordance with procedures outlined in the EP.
Team Leader/ Supervisor	<ul style="list-style-type: none"> • Ensuring adequate HSE management and action plans exist for every activity and site for which they are responsible. • Ensuring employees and HSE committees are appropriately involved in the development of HSE management plans. • Ensuring all individuals for whom they are responsible are adequately skilled for tasks they are expected to perform. • Ensuring work processes are fit for purpose. • The use of company-wide procedures in the site’s HSE management plans. • The development, review and close out of corrective actions in response to lessons learnt, incidents, defects, hazards, inadequacies of procedures and suggested improvements reported within their area of responsibility. • Providing appropriate resources for compliance with HSE laws and management of HSE risks in accordance with their delegated authorities. • The escalation of issues to the next level of management when the issue impacts other areas. • Implementation of leadership requirements as specified in the HSE MS. • Fulfilling emergency response and crisis management roles as defined in the Wandoo ERP.

Role	Responsibilities
HSE Manager	<ul style="list-style-type: none"> • Providing advice and guidance on the implementation of the HSE MS, which include this EP. • Assisting in the development of the EP and Wandoo Field OSCP. • Preparing and ensuring delivery of HSE content at inductions. • Preparing monthly report to NOPSEMA outlining non-conformances with performance standards outlined in this EP. • Ensuring EP compliance report is prepared and submitted to NOPSEMA. • Maintaining EP commitment register. • Undertaking chemical assessment process. • Leading and participating in incident investigation and analysis. • Promoting, facilitating and driving the implementation and continuous improvement of the HSE MS. • Providing general support for, and coordination of HSE MS related assessments, audits and training activities. • Stewarding HSE MS follow up action logs for the site. • Liaising with regulatory and other government departments as required. • Coordinating incident reporting internally and communicating to external agencies. • The custodianship and administration of HSE MS Element 10 – Security Management. • Fulfilling emergency response and crisis management roles as defined in the Wandoo ERP and Wandoo Field OSCP.
HR Coordinator	<ul style="list-style-type: none"> • Ensuring training and competency by developing and implementing a process to identify, evaluate and review competency needs for each level and function. • Ensuring all personnel are inducted to the requirements of the HSE MS including this EP. • Developing and maintaining a training matrix. • Selection and recruitment to ensure personnel meet the demands of their position.
Contract Manager	<ul style="list-style-type: none"> • Considering HSE and operation performance in the selection of contractors, vendors and service providers and ensures services and products. • Informing all contractors, vendors and service providers of VOGA's HSE and operation expectations including relevant procedures and practices and emergency plans. • Regularly monitoring contractors, vendors and service providers to ensure compliance with VOGA expectations.

Role	Responsibilities
All VOGA personnel and contractors	<ul style="list-style-type: none"> Following procedures that implement the requirements of the VOGA HSE MS, including this EP. Following instructions and training and carrying out their work in a manner which does not present a risk to themselves, others or the environment. Participating in HSE activities and systems. Reporting all incidents, defects, hazards and inadequacies of procedures so that appropriate review and corrective action can be taken. Fulfilling emergency response and crisis management roles as defined in the Wandoo ERP.
Vessel master	<ul style="list-style-type: none"> Ensures that all operations on board the vessel are carried out in accordance with environmental legislative requirements, commitments, conditions and procedures as provided in this EP. Ensures monitoring is undertaken in accordance with EP requirements. Report all incidents to the VOGA Field Superintendent.

7.5 Training and competency

The Operations Manager has responsibility for ensuring the competency of personnel involved in operations activities, in accordance with Element 5 of the HSE MS. The competence of VOGA personnel involved in operational activities is assured through the employee selection processes. Recruitment process records are maintained.

Ongoing training requirements are identified through individual training needs analysis to ensure competency requirements are maintained. Annual performance reviews undertaken on VOGA staff includes a review of HSE performance.

Information sessions are undertaken as required to ensure all employees are kept aware of HSE MS requirements, including compliance with environmental performance standards outlined in this EP.

7.5.1 Induction

All personnel working on activities under this EP will receive an induction that includes the following information:

- VOGA's HSE Policy;
- Major project risks and their associated mitigation strategies;
- Emergency response;
- Regulatory and procedural requirements;
- Environmental sensitivities of the area;
- Waste management; and
- Chemical and hydrocarbon spill prevention and spill response measures.

Inductions will be conducted on WNB to communicate and assign responsibility for field-based Wandoo Field EP performance standards; and emergency response roles and responsibilities.

7.6 Implementation of performance standards

7.6.1 Overview

The process of defining and determining VOGA's performance outcomes, standards and measurement criteria are defined in Section 5. The implementation framework is based on the right-hand side loop of the Performance Standards cycle in Figure 7-3 'Sustain Performance of Critical Control Measures,' as part of the Ongoing Operations and Risk Management component of the performance improvement process. The framework includes four key areas:

Apply and maintain control measures: Addressed through the implementation of VOGA's HSE MS and operations and maintenance routines;

Verify and monitor compliance: Conducted using the Wandoo Facility EP Commitment Register.

Investigate, assess and manage performance deviations: When a control fails to meet its defined performance standard the Operations team utilises the MoC process to assess the change in risk and identify appropriate risk management strategies;

Management of change: Changes to the facility for operational purposes, changes due to investigation into a performance deviation and changes to performance standards themselves are all assessed through VOGA's MoC process which addresses the potential impact of the change to the environment.

7.6.2 Wandoo Facility EP commitment register

The Wandoo Facility EP commitment register has been developed to verify compliance with environmental performance outcomes and standards outlined in this EP. The commitment register outlines performance outcomes, standards and measurement criteria, the VOGA personnel responsible for monitoring compliance with each performance standard and the EP risk number the performance standard applies to.

The Operations Manager will ensure that all personnel (including contractors) are aware of their responsibilities with regard to ensuring compliance with performance outcomes and standards and that processes are in place to meet them.

Verification of compliance with performance standards and objectives will be undertaken by internal and/or external audits and inspection.

7.7 Management of performance deviations

VOGA recognises that it is important to manage deviations from performance standards to ensure that changes in risk levels are understood and continually managed.

Critical Controls are management controls that have a key role in preventing, detecting, controlling or mitigating a MAE, or CEE. Many of the Critical Controls are shared between the Safety Case and EP. Due to the potential high level of impact, VOGA has a more stringent oversight and approval process for performance deviations. The management of deviations is outlined in VOGA's Risk Management Manual [VOG-2000-MN-0001] and Deviation Risk Assessment [VOG-2000-RD-0014].

The Deviation Risk Assessment (DRA) procedure involves a systematic evaluation of risks associated with a deviation; with the subsequent implementation of mitigation measures where necessary, which will ensure the identified risks associated with an environmental event assessed to have a catastrophic impact under the VOGA risk matrix remain ALARP.

The EP defines the approved operating envelope which is informed by risk assessments. The purpose of the DRA process is to ensure that VOGA activities are conducted within the safe operating envelope. In the event that there is, or expected to be, a deviation from the safe operating envelope, a DRA should be conducted.

Deviations to activities, management controls or environmental risks will be reviewed to confirm that any changes assessed as significant will trigger a revision to the EP.

The DRA process also identifies risk management strategies required to ensure risk levels are tolerable and ALARP.

Deviations are managed by VOGA's 'Deviation Risk Assessment Form'. The DRA is a documented risk assessment tool that addresses deviation risk management requirements outlined above. Review and approval of the DRA is obtained from Engineering, HSE and operations representatives. Where required implementation of contingency actions is managed by the MoC process (Section 7.8) contained within the Wandoo Work Management Manual [WPA-7000-YG-0021]. Operation directives may be issued to communicate contingency actions to relevant VOGA personnel.

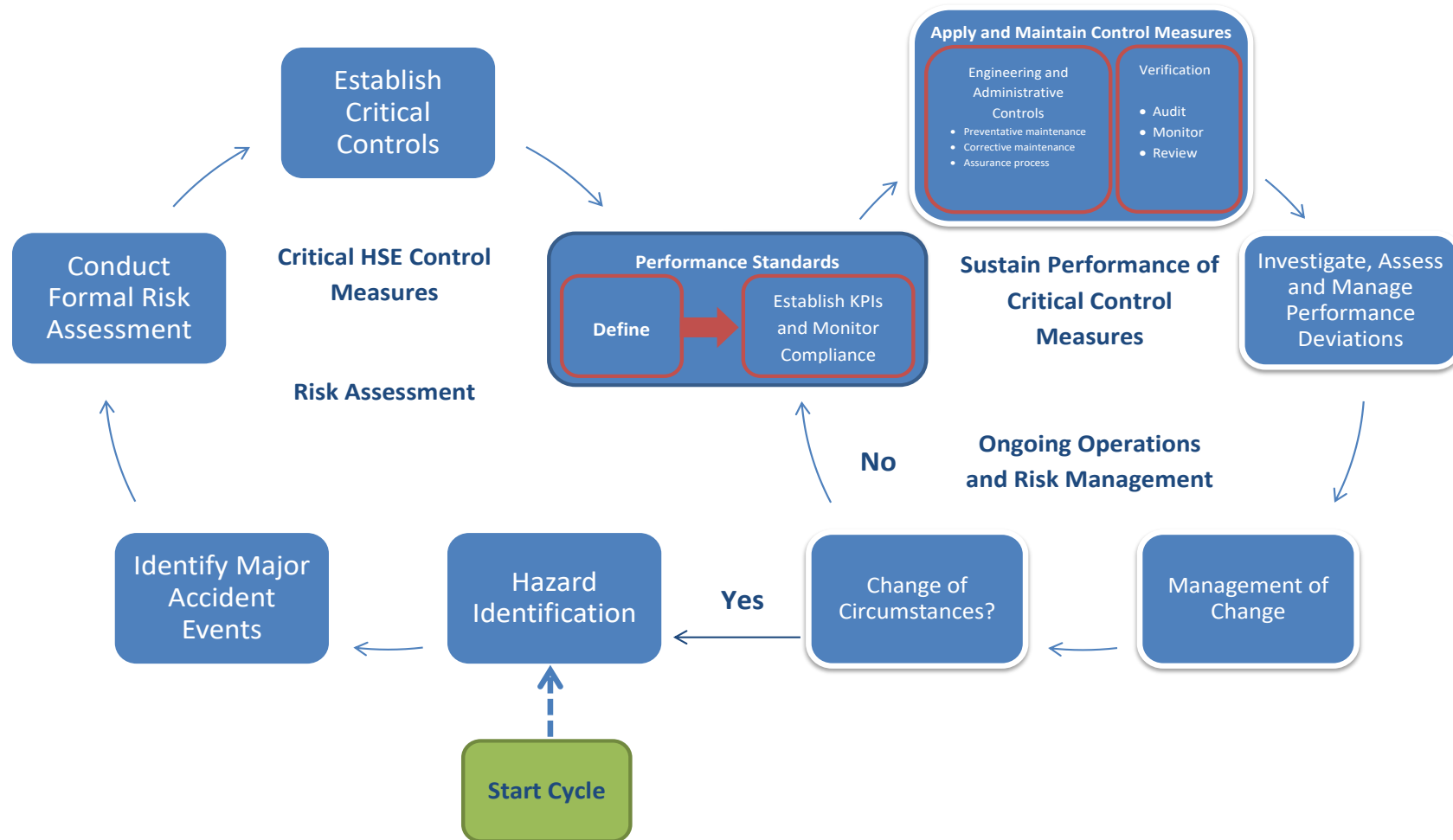

Figure 7-3: Performance standards and continuous improvement (adapted from NOPSEMA Control Measures and Performance Standards' Guidance Note, 2011)

7.8 Management of change

7.8.1 Overview

VOGA has implemented Element 4 to manage physical changes, staffing changes, organisational changes and operational changes at Wandoo. MoC is a critical management system process as it ensures that all modifications associated with the Wandoo facilities are subjected to appropriate scrutiny, review and assessment.

The expectations of HSE MS Element 4 include:

- A practice exists to assess, approve and manage all changes related to HSE matters, temporary and permanent, affecting personnel, organisations, design parameters, operations, procedures, materials, products, services, and work practices;
- A system exists which identifies and incorporates changes to laws, regulations and non-regulatory requirements into designs, operations, procedures, and work practices;
- Affected personnel understand the impact of changes being made and have appropriate skills and knowledge to manage the associated hazards;
- Risk assessments are updated during any type of change; and
- Drawings and other documents verifying changes are identified, current, and accessible.

The MoC form/checklist and the Change Management Process within the Work Management Manual [WPA-7000-YG-0021] are used to ensure that changes are evaluated, approved and documented prior to implementation. Field changes are initiated to resolve an operational problem or to improve safety, environmental performance or efficiency. They include modifications to facilities, changes to operating conditions and procedures, non-routine critical operations, and major plant and equipment testing.

7.8.2 Process

VOGA manages temporary and permanent changes through the same MoC process which utilises a business/technical approval form (MoC) and MoC Checklist.

The MoC form provides a documented record of the change, including justification for the change, duration of change, engagement and communication, implementation, monitoring and review and authorisation and sign-off.

The MoC checklist is completed for every proposed change. The checklist includes high level screening of those changes which may impact on environmental aspects of:

- Regulatory compliance (mandatory for all changes);
- Environmental (review triggered if there are changes in impact or management of emissions or spill hazards); and
- Chemical storage, usage and handling (review triggered on introduction of a hazardous good).

Actions required to assess the impact of the change are identified through the MoC checklist and recorded on the MoC Form.

If a change requires further investigation into the acceptability or impact of an environmental consequence, that investigation is done in accordance with the assessment methodology described in Section 5 and where required compared against the outcomes in Section 6.

Updates to the Wandoo Facility EP are identified within the MoC checklist process and assessed whether the update to the wandoo Facility EP requires a submission to the Regulator for acceptance.

Section 7 of the MOC process identifies whether proposed change requires updates to, or development of, key documentation such as management system procedures or equipment maintenance and inspection plans.

7.8.3 Regulatory compliance

For those changes which have been assessed as having the potential for environmental regulatory compliance aspects the following questions are addressed:

- Could the change modify an existing Environment Performance Outcome or Standard within the EP?
- Does the change propose significant modification, new stage of activity or are the activities to be carried out different from the activities contemplated in the accepted EP?
- Could the change result in a significant change in the overall level of risk and impacts identified in EP?
- Does the proposal change the HSE MS or an implementation plan within an accepted EP?
- Does the change require modifications to water treatment equipment or the composition of water discharge?

Consistent with sub-regulation 17 of the OPGGS(E) Regs 2009 and VOGA will revise the Wandoo Facility EP and submit for regulatory acceptance if there is a proposed change which will result in at least one of the following:

- a new activity not provided for within this EP, or an alternate in-force EP;
- a significant modification to the activity;
- a new stage of the activity;
- a significant change to impact or risk, a series of impacts or risks, or a new impact or risk not provided for within this EP.

In accordance with the NOPSEMA Guideline – When to submit a proposed revision of an EP (N04750-GL1705), VOGA considers the following aspects when determining whether a modification, meaning how the activity is being managed and/or conducted, is significant:

- There is a change to the spatial or temporal extent of the activity not provided for within this EP;
- continual reduction of the impacts and risks of the activity to ALARP;
- the effect the change has on the ability to demonstrate environmental performance outcomes and standards are being met;

- the criticality of the aspect being changed (i.e. a management system change is likely more critical because of its coverage of all impacts and risks as opposed to an individual item of equipment);
- the degree of deviation from how the activity was described in the EP.

A new stage of an activity is considered to be any change to the timing or spatial limits detailed in the accepted EP.

For individual changes, VOGA considers a change to be a “significant change to impact or risk” if:

- There is a resultant step change in overall risk level (see Section 5.6) of an environmental hazard – whether by reassessment with updated information or an actual increase in impact or risk; or
- A change in environmental impact profile from emissions introduces new relevant stakeholders or requires additional communication and agreements with existing relevant stakeholders.

For the changes assessed as “significant”:

- If planned, the change will not be implemented without Regulatory acceptance; or
- If unplanned, e.g. initiated by incident, the change may be managed and implemented prior to resubmission. In this instance a report and notification to the Regulator will be made in accordance with Section (8) Depending on the situation a resubmission of the Wandoo Well Facility EP to the Regulator maybe required post the event. Cumulative impact of minor changes are reviewed as part of the annual reporting process. For these items, changes will have most likely been implemented prior to Regulatory submission.

7.8.4 Continuous improvement

Continuous improvement is the process of enhancing the VOGA HSE MS to achieve improvements in overall environmental performance. The VOGA HSE Policy and the VOGA HSE MS provides criteria for ongoing assessment of environmental performance. This is achieved through the Performance Assessment Manual [VOG-1000-MN-0003], which outlines the monitoring and assessment tools and processes VOGA uses to monitor HSE performance and compliance.

Performance assessment is conducted to monitor effectiveness, provide assurance and identify improvement opportunities. Assessment of HSE performance generally encompasses:

- Monitoring, measurement, analysing and reporting HSE data;
- Conducting HSE audits and inspections, according to performance standards, pre-established intervals and ad hoc safety critical situations;
- Tracking and close-out of HSE actions; and
- Conducting management reviews.

Performance monitoring is primarily achieved by establishing and reporting on leading and lagging KPIs. VOGA annually reviews and sets the HSE KPIs for Wandoo, with the performance reported monthly to management. Quarterly HSE performance reports are provided to the HSE Subcommittee of the Vermilion Energy Board in Canada.

In addition, HSE report on key production items such as OIW performance and critical equipment out of service in the daily and weekly reports.

HSE MS documents are updated as required to include changes of procedure, corrective actions and new guidelines. The HSE Manager will look at methods of ensuring continual improvement over the duration of operations, focusing on incorporation of lessons learnt.

7.9 Emergency management

7.9.1 Wandoo Emergency Response Plan

7.9.1.1 Overview

The Wandoo ERP [VOG-2000-RD-0017] provides details on the response arrangements and responsibilities VOGA has for the management of emergencies which may occur during Operations. Incidents are categorised in relation to the response required:

- **Level 1 incidents:** Generally able to be resolved through the application of local or initial resources only (e.g. first strike response);
- **Level 2 incidents:** More complex in size, duration, resource management and risk and may require deployment of jurisdictional resources beyond the initial response; and
- **Level 3 incidents:** Characterised by a degree of complexity that requires the Incident Commander to delegate all incident management functions to focus on strategic leadership and response coordination and may be supported by national and international resources.

More detailed response plans have been developed to address particular events (e.g. the Wandoo Field OSCP [WAN-2000-RD-0001], Wandoo Source Control Contingency Plan [WNB-3000-PD-0007] and Concrete Gravity Structure Source Control Plan [VOG-3000-YH-0001].

7.9.2 Source Control Plans

7.9.2.1 Wandoo Source Control Contingency Plan [WNB-3000-PD-0007]

The Source Control Contingency Plan [WNB-3000-PD-0007] is focused on source control for wells. The plan provides campaign-specific details relating to reservoir conditions, blowout taskforce team structure, and logistics. The purpose of the document is to have as much planning as possible conducted upfront to minimise the response time of remedial measures.

There are several generic phases to bring an uncontrolled hydrocarbon release under control:

- Phase 1: Initial response, convene ICT and gather information;
- Phase 2: Determine most efficient well kill method;
- Phase 3: Detailed planning of the well kill operation;
- Phase 4: Execute well kill operation;
- Phase 5: Clean-up operation; and
- Phase 6: Incident Investigation.

Source Control arrangements are further described in 6.2.6.1.

7.9.2.2 Concrete Gravity Structure Source Control Plan [VOG-3000-YH-0001]

The CGS Source Control Plan [VOG-3000-YH-0001] provides a response framework to implement to minimise the volume of oil spill originating from CGS. The response is under the Wandoo ERP [VOG-2000-RD-0017] and runs in parallel to the oil spill ICT. Arrangements are further described in Section 6.4.

7.10 Oil Pollution Response

7.10.1 Overview

Under Regulation 14(8), the implementation strategy must contain an oil pollution emergency plan (OPEP) and provide for updating the OPEP. Regulation 14(8AA) outlines the requirements for the OPEP which must include adequate arrangements for responding to and monitoring oil pollution. As part of the implementation strategy, VOGA has developed an OPEP (WAN-2000-RD-0001.02).

A summary of how this EP, the OPEP and supporting documents address the various requirements of Environment Regulations relating to oil pollution response arrangements is shown in Table 7-3.

Table 7-3 OSR Regulations

OPGGS(E) Reference	Regulation	Relevant Section of EP
13(5), (6), 14(3)	Details of (oil pollution response) control measures that will be used to reduce the impacts and risks of the activity to ALARP and an acceptable level	EP (Section 6.2.8.4) documents the ALARP assessment of response strategies. Assurance and capability management process described in the EP (Section 7.10.7) ensures that environmental impacts and risks of spill response activities will be continuously identified and reduced to ALARP.
14 (8)	The implementation strategy must contain an oil pollution emergency plan and provide for the updating of the plan.	OPEP (WAN-2000-RD-0001.02) and EP Section 7.10 EP (Section 7.13.3) describes plan review and update process
14 (8AA)	The oil pollution emergency plan must include adequate arrangements for responding to and monitoring oil pollution, including: (a) the control measures necessary for timely response to an emergency that results or may result in oil pollution; (b) the arrangements and capability that will be in place, for the duration of the activity, to ensure timely implementation of the control measures, including arrangements for ongoing maintenance of response capability; (c) the arrangements and capability that will be in place for monitoring the effectiveness of the control measures and ensuring that the environmental	EP (Sections 6.2.8.4; and Critical Procedure Performance Standard – Oil Spill Response WAN-WNAB-CP-ER-02 and WAN-WNAB-CP-ER-03 – Appendix 5) documents control measures and performance criteria for oil spill response, with corresponding assurance activities to measure performance. This includes control measures for ongoing maintenance of response capability (WAN-WNAB-CP-ER-02-01 OSR Arrangements). Arrangements for ongoing maintenance of response capability are documented in EP (Section 7.10.7)



OPGGS(E) Reference	Regulation	Relevant Section of EP
	<p>performance standards for the control measures are met;</p> <p>(d) the arrangements and capability in place for monitoring oil pollution to inform response activities.</p>	<p>Arrangements and capability to implement control measures, including monitoring oil pollution to inform response activities, are described as follows:</p> <p>OPEP Sections 2 & 3 detail the resources needed, timeframes and guidance on implementation.</p> <p>Logistics Management Plan (VOG-7000-RH-0008), described in EP (Section 7.10.6) details the specification for each resource requirement, identifies contracts and arrangements required to be in place, and details the process for sourcing, activation and mobilisation.</p> <p>Oil Spill Response Capability Review [VOG-7000-RH-0009] contains up-to-date capability assessment of equipment and personnel.</p> <p>Arrangements and capability to monitor effectiveness of the control measures and ensure performance standards are met are the assurance activities documented in Critical Procedure Performance Standard – Oil Spill Response WAN-WNAB-CP-ER-02 and WAN-WNAB-CP-ER-03 and described in EP Section 7.10.7</p>
14 (8A)	<p>The implementation strategy must include arrangements for testing the response arrangements in the oil pollution emergency plan that are appropriate to the response arrangements and to the nature and scale of the risk of oil pollution for the activity.</p>	EP Section 7.10.7
14 (8B)	<p>The arrangements for testing the response arrangements must include:</p> <p>(a) a statement of the objectives of testing; and</p> <p>(b) a proposed schedule of tests; and</p> <p>(c) mechanisms to examine the effectiveness of response arrangements against the objectives of testing; and</p> <p>(d) mechanisms to address recommendations arising from tests.</p>	EP Section 7.10.7



OPGGS(E) Reference	Regulation	Relevant Section of EP
14 (8C)	<p>The proposed schedule of tests must provide for the following:</p> <ul style="list-style-type: none"> (a) testing the response arrangements when they are introduced; (b) testing the response arrangements when they are significantly amended; (c) testing the response arrangements not later than 12 months after the most recent test; (d) if a new location for the activity is added to the environment plan after the response arrangements have been tested, and before the next test is conducted—testing the response arrangements in relation to the new location as soon as practicable after it is added to the plan; (e) if a facility becomes operational after the response arrangements have been tested and before the next test is conducted—testing the response arrangements in relation to the facility when it becomes operational. 	EP Section 7.10.7
14 (8D)	<p>The implementation strategy must provide for monitoring of impacts to the environment from oil pollution and response activities that:</p> <ul style="list-style-type: none"> (a) is appropriate to the nature and scale of the risk of environmental impacts for the activity; and (b) is sufficient to inform any remediation activities. 	OSMP (WAN-2000-RD-0001.03)
14 (8E)	<p>The implementation strategy must include information demonstrating that the response arrangements in the oil pollution emergency plan are consistent with the national system for oil pollution preparedness and response.</p>	EP Section 7.10 OPEP

7.10.2 Spill Management Arrangements

7.10.2.1 Jurisdictional Authority

The jurisdictional authority is the State, Territory or Commonwealth agency with jurisdictional authority for marine pollution in its area of jurisdiction. NOPSEMA is the jurisdictional authority for offshore oil and gas exploration and production activities in Commonwealth waters, while AMSA is the jurisdictional authority for vessel-based activities in Commonwealth waters.

The Department of Mines and Petroleum (DMP) is the jurisdictional authority for offshore oil and gas exploration and production activities in State waters, while the DoT is the jurisdictional authority for vessel-based activities in State waters and is also the HMA for Marine Oil Pollution. In the event of marine pollution in State waters, the HMA (DoT) is the designated jurisdictional authority, regardless of the source.

In the event that a spill is predicted to move outside Australia's economic zone, the Australian Government is required to notify the international governments. In this situation VOGA will notify

DIIS who will notify the Department of Foreign Affairs and Trade, who will in turn notify the relevant foreign government. Vermilion plans a response (and supporting arrangements) based on the potential spill trajectory and will work with Federal Government and spill response agencies to coordinate the response across international boundaries.

7.10.2.2 Control Agency

The National Plan describes the control agency as the agency or company assigned by legislation, administrative arrangements or within the relevant contingency plan, to control response activities to a maritime environmental emergency. The control agency will have responsibility for appointing the Incident Controller (VOGA uses the term 'Incident Commander').

As outlined in Table 7-4, VOGA is the Control Agency for oil spills wholly confined to Commonwealth waters from production facilities, meaning VOGA is responsible for assuming Incident Control and providing an Incident Controller (Commander). In the event that a spill has any potential to enter State waters; the WA DoT will be notified as soon as reasonably practicable. For spills arising from ships and vessels within Commonwealth waters, VOGA may undertake initial response actions and will hand over Incident Control to AMSA.

In accordance with State Hazard Plan - MEE, the Controlling Agency for a Level 1 MOP emergency in State waters resulting from an offshore petroleum activity is VOGA. The Controlling Agency for a Level 2/3 MOP emergency in State waters resulting from an offshore petroleum activity is DoT.

Cross jurisdictional response activities are those activities that arise as a result of an incident originating in Commonwealth waters and requiring DoT to exercise its HMA obligations in State waters. A partnership between VOGA and DoT is required to ensure response activities across the entire incident are carried out.

Where State waters are impacted by a Level 2/3 MOP emergency resulting from an offshore petroleum activity in Commonwealth waters, DoT will only assume the role of Controlling Agency for that portion of the response activity that occurs within State waters.

Dispersant use in and around State waters must be approved by either DoT or the DMP (see DoT's Dispersant Use Guidelines for further information).

Table 7-4: Control agency by location

Spill response/ impact location	Spill source	Control agency	Relevant OSCP
Commonwealth waters	VOGA facilities	VOGA	Wandoo Field OSCP
	Ships and vessels	VOGA/AMSA	Wandoo Field OSCP/ National Plan
State waters	VOGA facilities	VOGA	Wandoo Field OSCP
		DoT	WA DoT OSCP
	Vessels not connected to the facility	DoT	WA DoT OSCP

7.10.3 Interface with other plans

7.10.3.1 VOGA Plans

To assist responders in the event of a spill, the Wandoo Field OSCP is split into two documents:

- The Wandoo Field Oil Spill Contingency Plan – Document 1: Planning and Preparedness (WAN-2000-RD-0001.01); and
- The Wandoo Field Oil Spill Contingency Plan – Document 2: Oil Pollution Emergency Plan (WAN-2000-RD-0001.02) including the supporting Wandoo Field Operational and Scientific Monitoring Plan (WAN-2000-RD-0001.03).

In the event of a spill, responders will immediately refer to the OPEP.

Document 1, Planning and Preparedness, is focused on outlining the basis of preparation of the OPEP and the processes for monitoring and maintaining response arrangements. The relevant sections of Document 1 are provided in this section of this EP.

The Wandoo Field OSCP interfaces with the following VOGA plans:

Wandoo Facility Emergency Response Plan [VOG-2000-RD-0017] – This plan describes the immediate ‘actions-on’ for an unplanned emergency incident at one of VOGA’s facilities. The Wandoo Facility Emergency Response Plan (ERP) is the plan that will be initially put in place to manage the immediate, life-threatening consequences of an emergency (e.g. fire, collision, etc.) and immediately mitigate, as far as possible, the consequences of these actions. The Wandoo Facility ERP will always have primacy over other plans.

Wandoo Source Control Contingency Plan [WNB-3000-PD-0007] – The Wandoo Source Control Contingency Plan provides a response framework to implement a well construction activity to intercept and plug/kill a well bore in the event of a continuous well release. The Source Control Response Team runs in parallel to the oil spill ICT. Both teams interface at the incident command level of the emergency response structure.

CGS Source Control Plan [VOG-3000-YH-0001] - The CGS Source Control Plan provides a response framework to implement to minimise the volume of oil spill originating from CGS. The response is under the Wandoo Facility ERP and runs in parallel to the oil spill ICT. Both teams interface at the incident command level of the emergency response structure.

Wandoo Facility EP [WPA-7000-YH-0007] – The Wandoo Facility EP caters for all operation and maintenance activities associated with the Wandoo Oil Field. The Wandoo Operations EP is developed by VOGA and accepted by the Designated Authority under the OPGGS(E)R. The Wandoo Operations EP identifies the environmental risks and impacts associated with the activities covered within the plan. This OSCP addresses all potential oil spill risks identified in the Wandoo Operations EP.

Wandoo Well Construction EP [WPA-7000-YH-0001] – The Wandoo Well Construction EP caters for well intervention and construction activities associated with the Wandoo A and Wandoo B platforms. The Wandoo Well Construction EP identifies the environmental risks and impacts associated with the activities covered within the plan, including oil spill response. The OSCP addresses all the response and recovery measures from the potential oil spill risks identified in the Wandoo Well Construction EP. The OPEP details the risk controls required to manage the environmental risks associated with the response activities.

Oil Spill Response Capability Review [VOG-7000-RH-0009] – The report provides a capability review for all oil spill response spill scenarios associated with production and well construction activities within the Wandoo Permit Area WA-14L. The capability assessment details the specification for each resource requirement (e.g. skills, vessels, equipment), basis of capability determination and identifies what contracts and arrangements are in place, or required, to meet the resource requirements. The requirements are ascertained and assessed through workshops, surveys and review of existing contracts.

7.10.3.2 Government and industry plans

The OPEP interfaces with the following Australian Government, State Government and Industry plans:

Australian Marine Oil Spill Plan (AMOS Plan) - This plan is managed by the Australian Marine Oil Spill Centre (AMOSC) and will be activated by VOGA when the response to an oil spill incident is regarded by VOGA to be requiring resources beyond those of the company. The plan coordinates the participation of the oil industry in response through the mobilisation of AMOSC personnel and/or equipment, which can be supplemented by personnel and equipment owned directly by other industry companies. As members of AMOSC, Chevron and Santos will respond with equipment and/or personnel to respond to a VOGA spill impacting on Barrow or Lowendal Islands respectively.

National Plan for Maritime Environmental Emergencies (National Plan) - Administered by the Australian Maritime Safety Authority (AMSA), the National Plan outlines Australia's arrangements for responding to oil spills in the marine environment, with the aim of protecting against environmental pollution as a result of oil contamination and, where this is not possible, minimise the effects.

The National Plan outlines combined stakeholder arrangements designed to allow a rapid and cooperative response to marine oil spills within Australian waters. Once accepted by the National Offshore Petroleum, Safety and Environmental Management Authority (NOPSEMA), the Wandoo Field OSCP is eligible for National Plan support. For the purposes of the Wandoo Field OSCP, the National Plan can be used to provide personnel, equipment and technical resources from the Australian and State governments to VOGA for use during a significant oil spill;

VOGA is a signatory to the AMSA Support for Oil Spill Preparedness and Response Memorandum of Understanding (MOU). AMSA will coordinate the resources of the National Plan on the formal request of the appointed Incident Commander. A liaison officer from AMSA will sit within the VOGA ICT to facilitate the effective and efficient coordination of National Plan resources; and

The Department of Transport (DoT) is a signatory to the inter-governmental agreement under the National Plan. The Oil Spill Response (OSR) Coordinator (Maritime Environmental Emergency Response Unit; MEER Unit), as well as some members of the State Response Team, are members of the National Response Team and are trained and competent in roles ranging from team leader for equipment operations and shoreline response to ICT roles. The MEER Unit has access to AMSA's National Plan equipment to respond to spills in State waters.

WA State Hazard Plan - Maritime Environmental Emergencies (MEE) - In accordance with the Emergency Management Act 2005, the State Hazard Plan - MEE has been formulated by the Hazard Management Agency (HMA) and approved by the WA State Emergency Management Committee (SEMC). This plan prescribes the management arrangements for the prevention of,

preparation for, response to and recovery from a MOP emergency in order to minimise the impacts of marine oil pollution from vessels, offshore petroleum activities and other sources in State waters.

For the purposes of the Wandoo Field OSCP, State Hazard Plan - MEE describes the response arrangements that the WA State Government will put in place for oil spills from the Wandoo Field, should they enter, or be predicted to enter, State waters and any shorelines or wildlife therein. This includes performing the function of Controlling Agency for response activities in State waters resulting from Level 2/3 incident in Australian Government waters as per the WA DoT Offshore Petroleum Industry Guidance Note MOP: Response and Consultation Arrangements (July 2020).

WA DoT OSCP – This describes the activities and actions that the WA DoT will undertake to mount a credible and proportionate response to oil pollution in State waters. For the purposes of the VOGA Wandoo OSCP, the DoT OSCP is complimentary in that it will be used to assist and guide the actions and activities that take place in State waters by the DoT in response to a spill from the Wandoo Field;

The DoT will work with VOGA to determine protection priorities and undertake an initial and ongoing environmental impact assessments to determine the most appropriate response in State waters. These protection priorities determined at the time of a spill may differ from those originally identified in the accepted OSCP. Dispersant use in and around State waters must be approved by either DoT or the Department of Mines and Petroleum – see DoT’s Dispersant Use Guidelines for further information; and

The State Marine Environmental Emergency Response Committee (SMEERC) which has representation from all agencies and authorities involved in marine OSR. In the event of a spill with any potential to impact State waters, DoT will coordinate the notification of all representatives on the SMEERC. This includes the State Environmental and Scientific Coordinator.

The Offshore Petroleum Industry Guidance Note - Marine Oil Pollution: Response and Consultation Arrangements (July 2020) (IGN) outlines the Petroleum Titleholders (VOGA) obligations to DoT and clarifies the Controlling Agency responsibilities and coordination arrangements for State waters responses.

Third Party Vessel Shipboard Oil Pollution Emergency Plans (SOPEPs) - These plans contain details about the ship, roles and responsibilities in the event of a spill, and spill response equipment on board. MARPOL 73/78 requires that every oil tanker of 150 tonnes gross tonnage and above, and every ship other of 400 gross tonnes and above, carry a SOPEP approved by the Administration. It is the same Shipboard Marine Pollution Plan that is required under the Oil Pollution, Preparedness, Response and Cooperation (OPRC) Convention;

Shipboard Marine Pollution Plans also include noxious liquid substances and should more correctly be called “Shipboard Marine Pollution Emergency Plan”. The plans must be prepared in accordance with vessel class and flag State requirements and guidelines as laid down by the International Maritime Organisation (IMO); and

All vessels that are involved in the activity will implement their SOPEP to assist in mitigating any spills from their shipping activities, which contributes to the mitigation of the overall oil spill risk from the petroleum activity.

7.10.4 Approach to response planning

VOGA's oil spill response planning process is based on impact and consequence scenario planning which involves establishing the context and risk; evaluating, demonstrating and defining response strategies and resources; implementation; and first response, as described in Table 7-5 and illustrated in Figure 7-4.

The process is divided into two phases: planning and spill response. The spill response is supported by the incident action planning process to ensure response is commensurate to potential impact; OPPs 1 and 2 are initial IAPs based on existing impact assessments for the spill and response activities within the relevant EPs.

7.10.4.1 Planning phase

As outlined in Table 3-1, preparing for spills involves the following steps to achieve the Wandoo Field OSCP outcomes:

- Step 1: Understanding the hazard profile - Outcome 1 of the Wandoo Field OSCP;
- Step 2: Identifying parameters to assess applicable response strategies and scale of the event - Outcome 2 of the Wandoo Field OSCP;
- Step 3: Identifying suitable response strategies - Outcome 2 of the Wandoo Field OSCP;
- Step 4: Understanding the impacts associated with response strategies - Outcome 2 and 3 of the Wandoo Field OSCP;
- Step 5: Ensuring capability and plan supports management of risks to ALARP - Outcome 4 and 5 of the Wandoo Field OSCP; and
- Step 6: Define the environmental performance standards within the respective EPs.
- The outcome of this approach is that:
 - Oil spill hazards associated with VOGA's activities are addressed and risks are managed to ALARP;
 - Response strategies (Table 7-1) and resources are based on the nature and scale of the incident;
 - Oil Spill Trajectory Modelling (OSTM) outputs for the operations and well construction loss of well control scenarios (category E) and loss of the CGS scenario (category F) were compared to ascertain a worst-case scenario for response planning by considering:
 - minimum time to impact defined environmental sensitivities;
 - probability of shoreline impact to defined environmental sensitivities;
 - maximum quantity of oil impact to defined environmental sensitivities; and
 - maximum length of oil impact to defined shoreline environmental sensitivities.
 - Response strategies are risk assessed and management controls outlined in both the Well Construction and Wandoo Facility EPs are considered in the OPEP.

7.10.4.2 Response phase

Initial response actions are described in the OPPs. These actions are based on the strategies, resources and capability identified in the planning process. Resources are activated and the

outputs from monitoring and evaluation are used to assess spill response impact, via the SIMA process, to confirm that the risks associated with response activities are consistent within the EPs and the Wandoo Field OSCP. If they are, then response effectiveness Key Performance Indicators (KPIs) are developed and response measures implemented. The incident action planning process provides for the opportunity to determine if response operations are effective and if termination criteria are met.

The incident action planning process used by the ICT allows for the effectiveness of each strategy to be reviewed, adjusted or halted if the objectives of the response are not being met or the environmental impacts were not addressed in the SIMA thus fulfilling Outcome 3 of the OSCP. If the impact of a response strategy is significantly higher than what is considered in the EP, then either impact of the strategy is unacceptable, or an EP revision is required for acceptance. An example of where a revision to an EP may be required is where new technology such as that for in-situ burning or bioremediation becomes available to VOGA.

To support this approach and provide a timely response, OPPs detail initial IAP's enabling response resources to be activated whilst event specific assessments are conducted. Resources are identified and capability to achieve timeframes has been reviewed to ensure first response actions are able to be implemented.

Table 7-5: Response Planning

Response Planning Steps	Where step is addressed in EP and/or OSCP
<p>Step 1: Oil spill hazard is identified and context for each spill category and season described. This requires understanding the potential events (scenarios) which requires knowledge of:</p> <ul style="list-style-type: none"> • API type, composition of reservoir/fluids assay. • reservoir modelling of oil type or another geotechnical analysis. • release rate, quantity, duration. • location of activity and potential spill sources. • metocean data matching the location and timing of activity. • location of environmental receptors and method of impact from oil. • toxicity of oil. • timing of spill (season). • thresholds. • EMBA of the activity. 	<p>To support a hazard-based approach to planning, oil spill scenarios outlined in this EP were initially grouped into spill categories based on fluid type, duration, and volume. Details for each scenario are provided in the following sections in this EP:</p> <ul style="list-style-type: none"> • liquid hydrocarbon release from wells (Section 6.2.3); • diesel spill to sea (Section 6.6.3); and • liquid hydrocarbon release from topsides process (Section 6.18)
<p>Step 2: Evaluate response parameters, is also about consideration of the hazard, as response preparation requires understanding the potential consequence including:</p> <ul style="list-style-type: none"> • probability of oiling defined environmental sensitivities. • minimum time to impact defined environmental sensitivities. • quantity of oil to impact defined environmental sensitivities. • length of shoreline impacted. • response operating area. 	<p>As a part of the hazard assessments in Section 6 of the EP, modelling was undertaken which was used to determine potential impacts and to identify the parameters for the response.</p>
<p>Step 3: Define response strategies for spill categories, involves designing the most appropriate response plan, such that the impacts, in the event of a spill, are reduced to ALARP. VOGA uses an assessment process for oil spill planning and response and in doing so consider:</p> <ul style="list-style-type: none"> • the oil spill hazard. • the context for each spill category and season. • operational constraints. • assess the impacts of the hazard and the response activities. • assess whether impacts from the hazard and the response activities are ALARP, by considering all alternatives and their relative benefits and costs. • where not determined to be ALARP, the response strategies are adjusted as part of an iterative process. • this iterative process considers capability and in doing so looks at the potential benefits and costs of doing more sooner. 	<p>Oil spill scenarios identified are grouped into categories based on the fluid type, duration and volume. There are six categories, further grouped into two response plans (OPP1 and OPP2);</p> <p>The response strategies planned are summarised in the Section 2.8.14 as well as being described in the respective OPPs;</p> <p>The response strategies are also assessed in Section 6.2.8.4 of this EP. This section describes the response strategy and assesses the risk of the hazard. It also identifies the critical stages of the response strategy and schedule for implementation which are evaluated further to determine if undertaking more of the techniques will provide additional benefit and/or if anything can be done sooner;</p>
<p>As a part of the planning the response, in Step 4: Assess impacts of spill scenario, VOGA also assesses the impacts of the spill response. This not only contributes to making choices about the response strategies, but also informs how the response should be undertaken to ensure that the risks and impacts of the response are managed to ALARP. This step involves:</p> <ul style="list-style-type: none"> • environmental risk and impact assessment. • OSTM of surface, entrained and subsurface oil with and without response strategies. • identification of the controls (including environmental performance outcomes, standards and measurement criteria) to be implemented as a part of the spill. 	<p>The potential impacts of each spill response strategy have been assessed in Section 6.5 of this EP, and it is demonstrated that they are ALARP.</p>

Response Planning Steps	Where step is addressed in EP and/or OSCP
<p>To ensure that VOGA has a level of preparedness to implement the response strategy Step 5: Define the response resources is undertaken next. In this step, VOGA considers:</p> <ul style="list-style-type: none"> operational limitations (equipment functional capacity/coverage, safety of response personnel). constraints of equipment effectiveness. scale of the spill event. skill-sets required for specific roles. 	<p>OPP's detail the resources needed, timeframes and guidance on oil spill response</p> <p>Logistics Management Plan [VOG-7000-RH-0008] details the specification for each resource requirement (e.g. skills vessels, equipment) and identifying what contracts and arrangements are required to be in place; details provided in Section 7.10.6</p> <p>Oil Spill Response Capability Review [VOG-7000-RH-0009] is undertaken annually based on the response activities outlines in the OPEP. For each statutory EP submission, the latest information from the Capability Review at time of the revision is provided in the OPEP.</p> <p>Assurance and capability management for OSR is detailed in Section 7.10.7 of this EP.</p>
<p>Step 6: Define the performance standards.</p> <p>Some of the spill scenarios have been identified by VOGA to be CEE with “emergency preparedness, management and response” identified as a critical control, requiring a specific Critical Procedure Performance Standard.</p> <p>The Critical Procedure Performance Standard (Element 8 - Emergency preparedness, management and response) has the objective “to ensure that measures are in place to provide effective response in the event of an emergency situation at Wandoo facilities”. To meet this objective, there are a number of key requirements of this overarching control, and performance criteria to set a level of performance, with corresponding assurance activities to measure performance identified.</p> <p>By working towards the objective, this Critical Procedure Performance Standard guides the manner in which VOGA plans for a response and ensures that the response is appropriate and will reduce the impacts to ALARP.</p>	<p>Sections 6.2.8.4; and Critical Procedure Performance Standard – Oil Spill Response WAN-WNAB-CP-ER-02 and WAN-WNAB-CP-ER-03 (Appendix 5) documents control measures and performance criteria for oil spill response, with corresponding assurance activities to measure performance.</p>

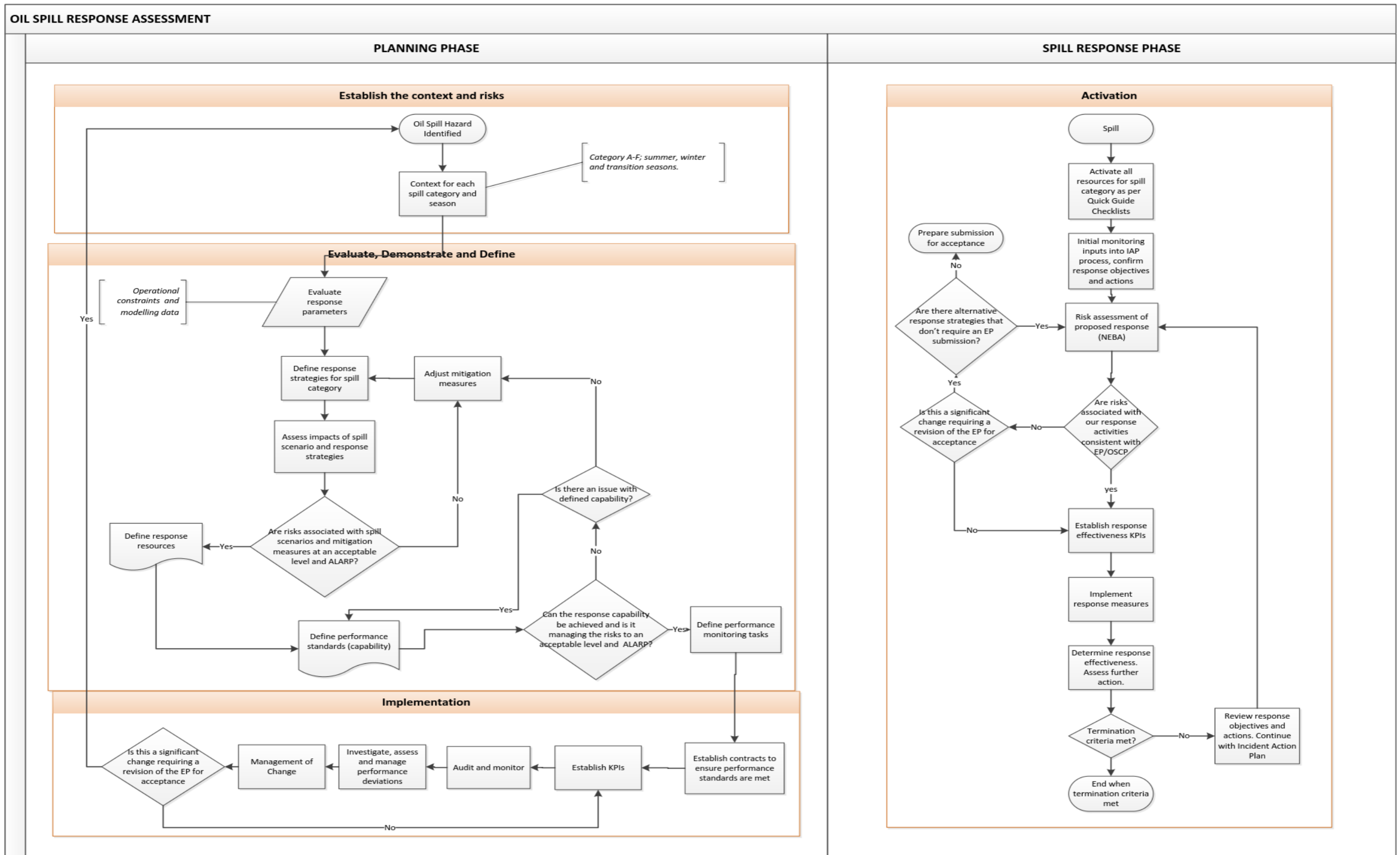

Figure 7-4: Response Planning Diagram

7.10.5 Incident management process

7.10.5.1 Response structure

VOGA has an emergency management response structure that is based around three levels of organisational control: tactical, operational and strategic. The premise behind these levels of control is that those parties within VOGA with the greatest expertise to manage that aspect of the emergency are empowered to do so, with operational or strategic levels stood up to provide support in terms of planning, resources and the management of extraneous issues that while important, are managed at the lower levels of control.

There are three teams within the emergency management response structure:

- Corporate Command Team (CCT).
- Incident Command Team (ICT).
- On-site Command Team (OCT)

Figure 7-5 represents the VOGA emergency management response structure and depicts the three levels of the Calgary based CCT, the Perth based ICT, and the On-site command team, including the links between teams.

The goal of the three teams within the VOGA emergency management response structure is to implement reasonable and proportionate response strategies until such time as the response may be terminated.

The teams will do this through an incident action planning cycle. Prudent over-caution is used by VOGA in responding to oil spills, i.e. CCTs and ICTs will be notified with a view to being stood up for oil spills, then stood down after size and scale have been assessed and verified.

VOGA’s ICT runs an incident control system analogous to the Australasian Inter-Service Incident Management System (AIIMS) to which the National Plan is also aligned.

The chain of command for incident response is depicted within the VOGA emergency management response structure, as presented in and Table 7-6. Personnel appointed to these functions are selected from within VOGA or, for protracted incidents that run for weeks or months, using trained National Response Team members, AMOSC and the AMOSC Core Group, international OSR support organisations, and from within the international resources of VOGA. Where required the DoT Incident Controller has input into the team composition and structure.

Table 7-6: Key ICT functions for Oil Spill Response

Role	Functional responsibilities
VOGA Incident Commander/ICT Leader	First point of contact for Person in Charge (PIC) offshore. Assists PIC to manage the response and calls out the ICT if required. Responsible for ensuring that an effective response is mounted by the On-site Command Team, and the onshore ICT. Approve IAP and where required engage State Maritime Environmental Emergency Coordinator/ DoT Incident controller for agreement/endorsement of plan for activities within, or potentially impact, WA waters.



Role	Functional responsibilities
DoT Incident Controller (Hazard Management Agency) and State Maritime Environmental Emergency Coordinator	<p>DoT Incident Controller (Hazard Management Agency) is the State appointed incident controller for oil spill response activities within, or potentially impact, WA waters.</p> <p>The State Maritime Environmental Emergency Coordinator provides overall strategic management of the response and executive level support and guidance to the DoT Incident Controller.</p>
Planning Chief Situation Resources Environment	<p>Supervises the VOGA ICT and leads the IAP process. Records and displays data for information, planning and programming, allocation and justification. Documents and maintain records of all Wandoo Offshore Installation and VOGA ICT actions. Manages critical information requirements.</p> <p>Interfaces with State Maritime Environmental Emergency Coordinator or State Environmental and Scientific Coordinator (ESC) for input into IAP for activities impacting state waters.</p> <p>The collection, processing and organisation of operational monitoring information, e.g. OSTM, weather, sea state.</p> <p>Tracking of the deployment of resources.</p> <p>Responsible for the collection and collation of environment data/advice, e.g. obtains environmental data from OSRA and scientific monitoring (DoT ESC and local sources) with support from an Environment Unit Lead role.</p>
Logistics Chief Procurement Services Transport Communications Medical	<p>Develops logistics plan to support operations and provides overall resource support to emergency incident sites. Establishes and maintains lists of personnel, supplies and materials which might be required to support the emergency/disaster. Responsible for establishing any Simultaneous Operations (SIMOPS) Plan to manage the risk generated by multiple activities.</p> <p>Acquisition of personnel and equipment.</p> <p>Acquisition of services and facilities, including waste management resources.</p> <p>Provision of air, land and sea transport services.</p> <p>Communications Sub-Plan and for ensuring the provision of communications services/support.</p> <p>Provision of medical services where needed.</p>
Operations Chief Marine Aviation Shoreline Wildlife Occupational Health & Safety (OH&S) Waste management	<p>Assumes responsibility for executing approved Action Plans. Responsible for all tactical command and coordination of in-country incident response assets in the assistance and support of the On-site Commander. Ensures that operational objectives and assignments identified in Action Plans are carried out effectively. Monitors operations; ensures necessary operational support is provided when and where required; allocates resources.</p> <p>Coordination and direction of all activities undertaken by waterborne craft and equipment.</p> <p>Coordination and direction of all activities undertaken utilising aircraft, e.g. aerial dispersant spraying, aerial surveillance and transport.</p>

Role	Functional responsibilities
	<p>Planning and coordination of shoreline assessment and clean-up activities (in consultation with the DoT, planning, specifically the environmental specialists). Implementation of shoreline clean-up activities.</p> <p>Implementation of the WA Oiled Wildlife Plan, i.e. the collection, treatment and rehabilitation of oiled wildlife in consultation with DBCA via the DoT ESC.</p> <p>Development and implementation of the OH&S Plan.</p> <p>Coordination of the containment, storage, transport and disposal of recovered oil and oily waste. Also, instruction in on-site handling, storage and/or separation and treatment.</p>
Finance Chief	Provides monetary, insurance, legal, risk and human resources, related administrative functions to support emergency operations and to preserve vital records documenting work performed and associated costs in the event of disaster or major emergency.
Safety Officer	Assesses unsafe situations and develops measures for assuring personnel safety. Confirms safety regulatory authorities and applicable departments have been notified. Ensures implementation of safety measures and monitoring and recording of personnel exposures to hazardous products. Supports accident investigations, recommends corrective action, and prepares accident report.
Corporate Command Team (CCT)	Focus of the CCT is on ensuring ICT are responding in accordance with corporate requirements, liability/insurance, business continuity, media/investor relations, and financial management/support of response.
Corporate Command Operations Chief	Provides the interface between the ICT and CCT. Provides updates to the CCT regarding IAPs and communicates any needs for support if required. Responsible for ensuring VOGA's corporate objectives are communicated to the ICT and are also reflected in the IAP.
Stakeholder Liaison Officer	Responsible for managing regulatory engagement and coordinating any regulatory approvals required to implement response strategies. Coordinates engagement of stakeholders who are impacted from the spill or response activities. Coordinates investigation of reportable events. Acts as the functional interface between these various parties. Implements VOGA Communications Plan, providing media information support and serving as the dissemination point for all VOGA media releases.
Liaison Officer (Industry)	Identifies the assisting and cooperating companies and agencies, including communications link and location; provides list to the CCT. Functions as "point of contact" for assisting and cooperating agency representatives. Responsible for ensuring that parties who have agreed to undertake specific functions under the OPEP are undertaking the functions consistent with the OSR strategies, performance standards and objectives of the VOGA Wandoo Field OSCP.

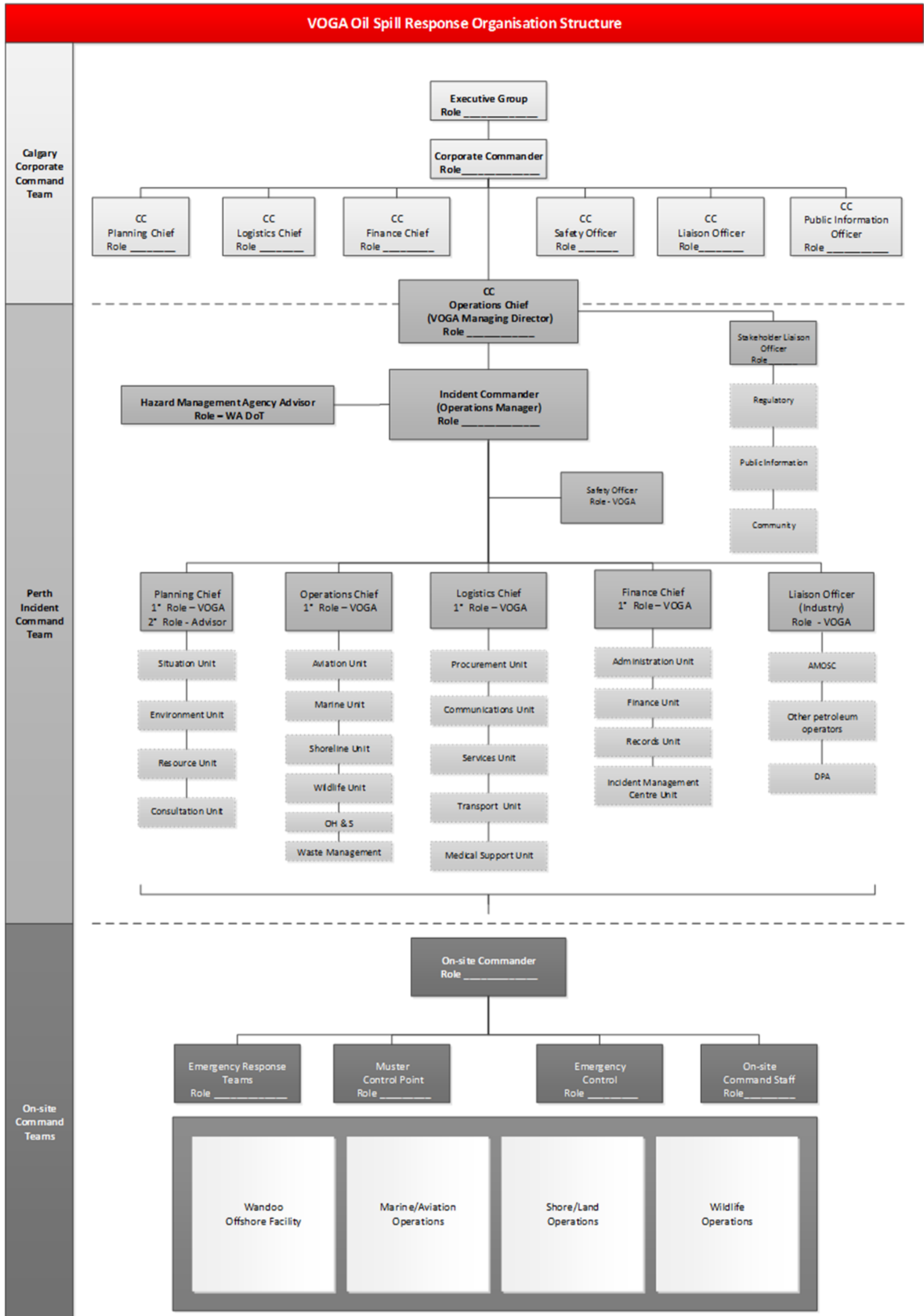

Figure 7-5: VOGA Oil Spill Response Structure

7.10.5.2 ICT response resources

Vermilion engaged a third-party expert to research and provide an appropriate method that could be used for VOGA to determine the level of ICT personnel required to undertake an effective response to VOGA's identified oil spill events. In summary, the research identified that:

- Other emergency management frameworks in Australia:
 - Did not have a publicly available method of quantifying the numbers of ICT personnel required to respond to incidents; and
 - Relied on the scalability of the ICS system with a focus on the minimum competence of staff to fill critical positions.
- Spill response case studies provide minimal instruction or value in determining the level of ICT personnel to support an oil spill clean-up because:
 - Different jurisdictions have different national response frameworks with some being led by government, others by industry, and others cooperatively;
 - Often the numbers of ICT staff are reported without any indication of the prior competence or training of personnel;
 - No correlations could be drawn between the response strategies employed in a response and the level of ICT staffing required to support a particular strategy;
 - There are too many variables (e.g., spill size, location, release point, personnel competence, environment effected, population density, political pressure) to be able to reasonably allocate case study ICT personnel numbers to any other situation.
- The only correlations across case studies could be that:
 - Cooperative national frameworks, such as those in Australia, tend to rely on lower overall ICT personnel numbers with a focus on ensuring minimum levels of competence are required for critical roles;
 - Spills at locations with higher population densities tended to engage higher numbers of ICT personnel.
- In Australia, the National Plan relies on fewer numbers of highly competent and broadly qualified individuals who can operate in a cooperative national system for its response operations. This is demonstrated by the training syllabus in the AMSA administered national oil spill response qualifications.

Based on this research VOGA has decided that, to be consistent with the National system for oil spill response in Australia, a methodology based primarily on ensuring competence personnel are positioned in the critical roles is the most appropriate for its activities.

Whilst a secondary consideration, it is also important that we have a method of determining the quantity of personnel required for our largest incident and that we have the arrangements in place to meet this need, catering for rosters in longer responses, potential 24hr ICT operations, personnel absences, and contingency capability.

The method in Figure 7-6 has been developed for VOGA to assess, and periodically review its ICT capability both in terms of competence and quantity. The method can also be used by the ICT in a response to validate plans and/or build new plans depending on the specific spill circumstances. It has been designed to determine an ICT capability for the largest demand of each response strategy collectively.

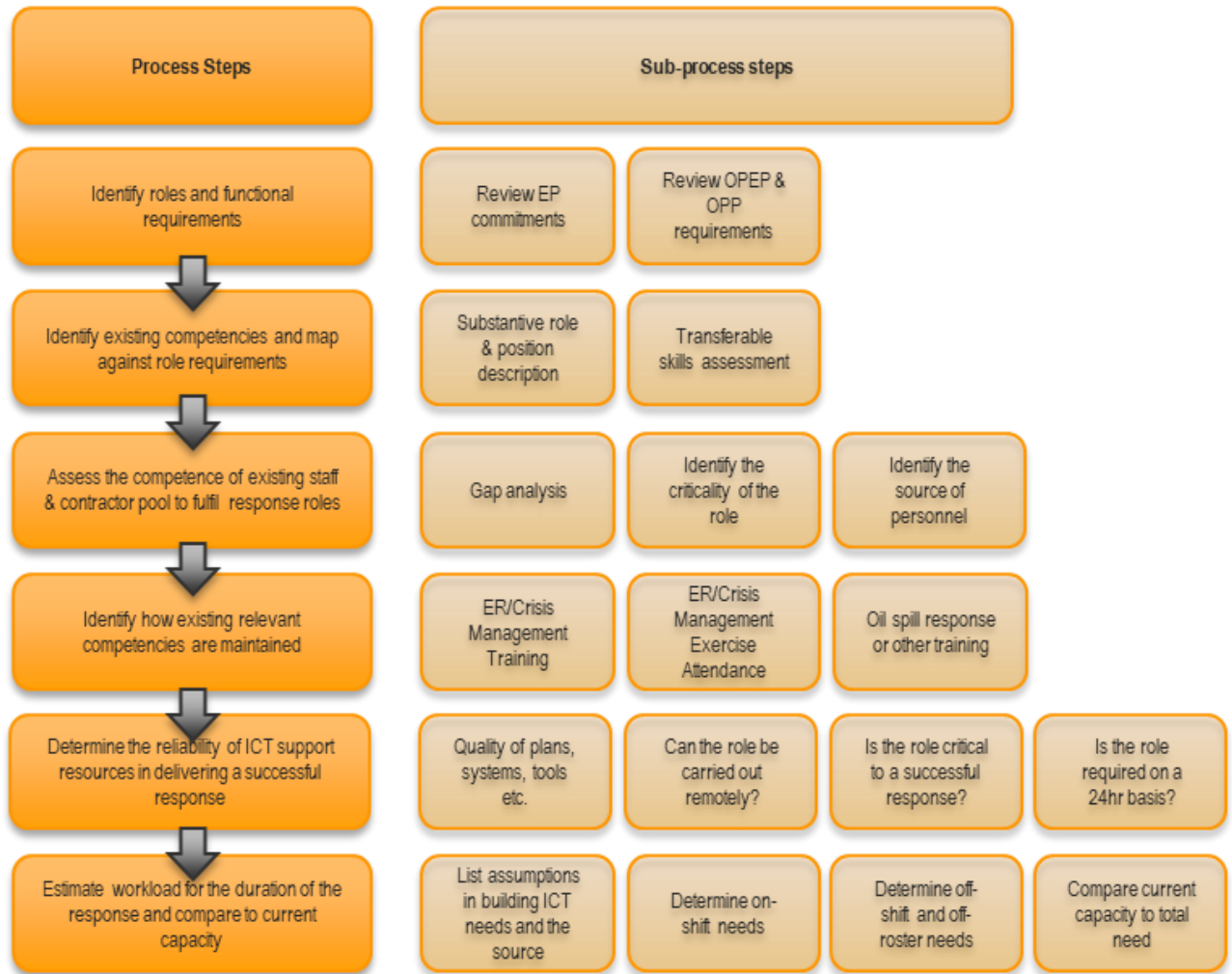

Figure 7-6 Process for determining the competence and quantity of ICT personnel

This process involved estimating the workload associated with a Category D, E, or F spill event, activation of Oil Pollution Plan 2 (OPP2). This is to recognise that one person can perform multiple workload is low in them all. It also recognises that some roles will be fully or partially filled by other agencies. For example, the WA DoT will run all aspects of the shoreline response meaning that the workload for the shoreline unit in the VOGA ICT is low. Assumptions about the expected workload on each functional role have been made at the 1-Day, 2-day, 5-day, 10 day, and 20-day intervals.

The process has also considered that some roles could be completed remotely and that Vermilion’s primary Tier 3 oil spill response organisation, AMOSC, has identified that their operating model for providing support is to provide its own ICT support for its own resources. This reduces the workload demand on the VOGA ICT and decreases the availability of AMOSC staff in other roles. These changes in response arrangements have been reflected in the process.

The ICT resource activation plan is provided in Section 5 of the OPEP. Oil spill exercises and testing are expected to further refine the assumptions and adjust the process over time.

VOGA manages our business and capability arrangements to ensure we have sufficient contingency, through training majority of office staff and managing leave; ensuring we have

sufficient capacity to maintain access to VOGA numbers as outlined in OPEP Table 5-2. Should situations arise where these numbers cannot be achieved a 'recordable' incident will be raised and will trigger review of operational activities to manage changes in risk profile.

The Oil Spill Response Capability Review [VOG-7000-RH-0009] process described in Section 7.10.7.2 ensure that VOGA maintains access to internal and external arrangement to meet the ICT resource requirements outlined in the OPEP Section 5.

7.10.5.3 Source control technical support teams

In the event of a well control incident the VOGA Incident Command Team (ICT) are responsible for managing the response in accordance with the Source Control Contingency Plan and the ERP. The ICT will be based in the VOGA Perth office and supported on technical aspects by dedicated technical support teams.

The Incident Commander will authorize the assembly of the following dedicated technical teams to undertake the well kill and relief well planning and execution activities:

- Well Control Response Team
- Subsurface Team
- Relief Well Planning Team

Each of these teams will be under the direction of the Well Construction Manager who will report to the Incident Commander to ensure a clear chain of command.

These teams will consist of VOGA personnel and/or potentially service contractors, dependent on the well control event category and if the event occurs during drilling or well intervention programs. VOGA has a consultant based offshore drilling team available during well construction and intervention programs that could be utilized for drilling a relief well. There are several consulting firms in Perth who specialise in the supply of suitably qualified personnel at short notice if VOGA decide more engineering support is required in their office or for offshore supervision.

VOGA has the option, with its international offices, to call on additional internal engineering support. VOGA's Perth office has agreements in place with most major service companies for equipment and personnel and can draw on a range of specialised personnel to assist in blowout response.

Table 6-6 of this EP details the resource requirements and arrangements of the technical support teams. The competency level required of the technical teams is managed through the well construction management process.

7.10.5.4 Cross jurisdictional arrangements

In all cross-jurisdiction MOP emergencies beyond Level 1, DoT will establish an IMT and VOGA will be required to provide an appropriate number of appropriately qualified personnel for the DoT IMT. This is an initial 11 personnel in accordance with the DoT Offshore Petroleum Industry Guidance Note – Marine Oil Pollution: Response and Consultation Arrangements (Version 5, July 2020) (DoT IGN). The control coordination arrangements for a Cross Jurisdiction MOP emergency are outlined in Figure 7-7.

Figure 7-8 from the Offshore Petroleum Incident Coordination Framework (March 2019) provides the strategic response structure between the Commonwealth and a state or territory jurisdiction may operate in the event of a cross jurisdictional incident. The Commonwealth strategic coordination group will change depending on the severity of the incident.

VOGA will conduct initial response actions in State waters as necessary in accordance with their OPEP and continue to manage those operations until incident control can be established by DoT.

VOGA and DoT will complete the Incident Control in State Waters Checklist (Appendix 1 of the DoT IGN) before establishment of incident control by DoT. VOGA will continue to provide planning and resources in accordance with the OPEP. This will include supplying response assets and contracts specified in their OPEP, such as waste management, transport and personnel as well as response arrangements using the Australian Marine Oil Spill Centre (AMOSOC) resources and other third-party responders. In fulfilling its obligations as Controlling Agency, DoT will require VOGA to work in partnership with DoT to ensure an adequate response is provided across the entire incident.

VOGA utilises a spill impact and mitigation assessment (SIMA) worksheet that provides information on sensitivities at risk, and feasibility and impact of response strategies based on the spill category and season. It incorporates the DoT Protection Priority Assessment for Zone 2: Pilbara – Final Report (16 Oct 2017). The SIMA and the Initial IAP prepared by VOGA will be provided to DoT at the time of initial notification of a spill potentially entering state waters.

To facilitate this overarching coordination between the two Controlling Agencies and their respective IMT's a Joint Strategic Coordination Committee (JSCC) will be established. The JSCC will be jointly chaired by the WA DoT State Maritime Environmental Emergency Coordinator and a VOGA nominated senior representative and comprise of individuals deemed necessary by the chairs to ensure an effective coordinated response across both jurisdictions.

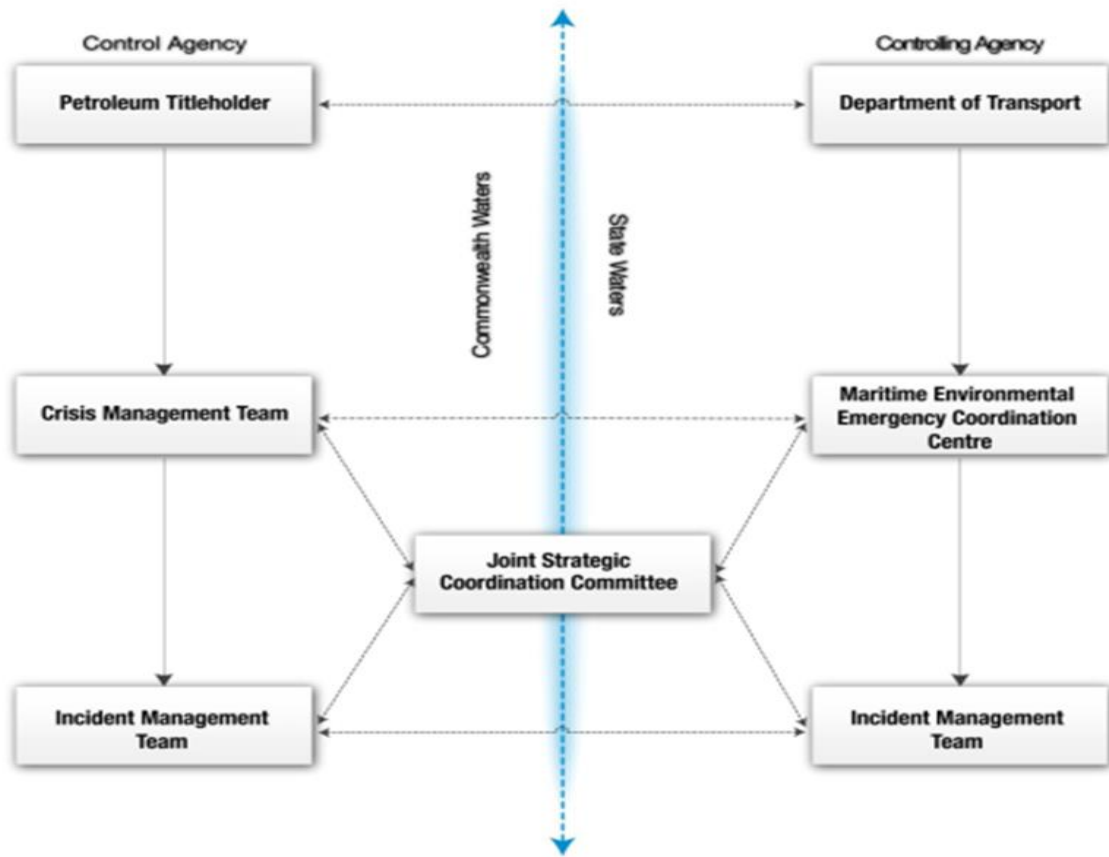

Note — DoT IMT contains an appropriate number of appropriately qualified persons from the Petroleum Titleholder in key areas commensurate with their level of introduced risk.

Figure 7-7: Cross Jurisdictional Response Structure

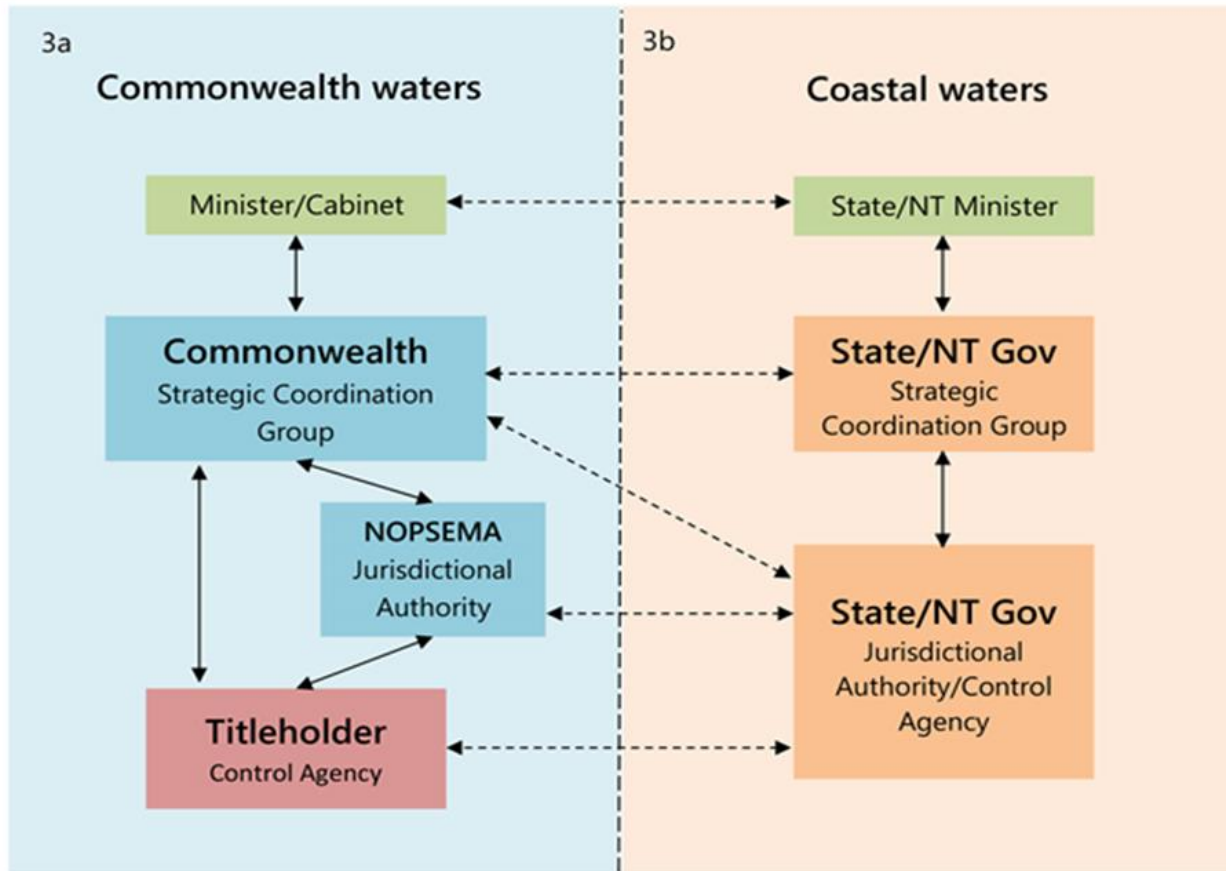

Figure 7-8: Offshore Petroleum Strategic Response Structure

7.10.6 Logistics Management Plan

7.10.6.1 Overview

The VOGA Emergency Response Logistics Management Plan [VOG-7000-RH-0008] contains outputs from the identification of resources required and the scope of works/services required to deliver those resources. It is maintained as live document based on the resources identified and the Contractor Scope of Works in the OSR Capability Review [VOG-7000-RH-0009]. The plan provides details of the logistics support available to support the implementation of the Oil Pollution Plans (OPP) outlined in the OPEP. Logistics requirements for smaller spills can be scaled down from this.

On activation of the ICT for OSR, incident specific logistic plans will be developed to support effective logistics management and deployment. Depending on the size of logistics activities, SIMOPS plans may be developed to manage the hazards associated with multiple logistics interfaces within a confined area. The Logistics Officer is responsible for managing the logistics and SIMOPS plans.

7.10.6.2 Roles and Responsibilities

Logistics Chief

The Logistics Chief is a member of the ICT and is responsible for providing facilities, services and

material in support of the incident. The Logistics Chief participates in the development and implementation of the IAP, activates and supervises the branches and units within the logistics section.

The function of this section is to provide support for the control of the incident through the obtaining and maintaining of human and physical resources, facilities, services, and materials.

Responsibilities of the Logistics Chief include:

- Developing the logistics component of the IAP ensuring that Planning Chief is provided with a list of resources available;
- Planning organisation of the logistics section;
- Allocating tasks to section personnel;
- Supporting control of the incident through the procurement and maintenance of human and physical resources, facilities, services and materials;
- Facilitating effective liaison and cooperation with all relevant persons;
- Providing progress reports on logistical support for the incident to the Incident Commander and the ICT;
- Estimating future service and support requirements; and
- Facilitating the establishment and maintenance of staging areas (if required) in support of the Operations Section.

Logistics units

Procurement Unit - The Procurement Unit acquires and distributes equipment and materials for infrastructure support. Ensures supplies are appropriately stored and maintained. Obtain extra resources (people, vehicles, equipment etc.) as required. Includes supporting the incident with the provision of food and drinks to personnel involved in the incident across the Incident Command Centre (ICC) and all on-ground sites across different meal times and duty shifts (taking into account specific dietary requirements).

Communications Unit - Provide input into the acquisition, installation and maintenance of communications equipment. Assist the Planning Section to produce the Communications Plan for the effective use of incident communications equipment and facilities; installation and testing of communications equipment; supervision of the Incident Communications Centre; distribution of communications equipment to incident personnel; and the maintenance of communications equipment.

Services Unit - The Services Unit obtains and manages the necessary facilities and accommodation to support operations and incident control and maintains them in working order. Responsible for the setup, maintenance and demobilisation of incident facilities, e.g. Base, ICC and staging areas, as well as security services required to support incident operations. Provides sleeping and sanitation facilities for incident personnel and manages Base operations. Each facility is assigned a manager who reports to the facilities unit leader and is responsible for managing the operation of the facility.

Transport Unit - The Transport Unit is responsible for providing transport for personnel, equipment, supplies and food, together with fuelling, mechanical maintenance and security of all

equipment and vehicles at the incident. Develop and implement a Traffic Management Plan for in and around the incident.

Other functions that support the logistics unit

Resource Unit (a Unit within the Planning Section that works closely with the Logistics Section) - This function gathers, maintains and presents information on incident resources and contributes to the plans for demobilisation. The Resource Unit Leader is responsible for maintaining the status of all assigned tactical resources and personnel at an incident. This is achieved by overseeing the check-in of all tactical resources and personnel, maintaining a status keeping system indicating current location and status of all these resources. Includes the tasks of resource management, resource tracking, changeover management and demobilisation (in accordance with demobilisation plan). VOGA plans to utilise planners to fulfil this role with offshore planners (if demobbed) to provide back-up support.

Responsibilities include:

- Establish and maintain a Resource Management System for the tracking of resources;
- Display resources as allocated (working), available (within a short time frame), enroute, resting, demobilised or unserviceable;
- Work closely with Staging Area Manager to ensure communication flow;
- Participate in mobilisation and demobilisation plans;
- Process requests from Operations Division(s) for additional resources in liaison with Logistics Coordinator; and
- Provide records/information to Media Liaison Officer.

7.10.6.3 Resource Arrangements

Two categories of contractors and support organisations have been identified to support VOGA respond to oil spills.

- Oil spill response specific support organisations; (including national, state and industry resources); and
- Existing operational contractors that can be engaged for emergency response activities.

AMOSC and AMSA are the first support agencies to be called, followed by Oil Spill Response Limited (OSRL) and the WA DoT if required. The first contractors to be called are likely to be the providers of aircraft and vessels.

During the development of the Incident Action Plan (IAP) the Planning Chief will be working with the Logistics Chief with the to identify the available resources and deployment time. The IAP will outline the priority response strategies and their locations, based on the potential incident escalation, impact of response activities and available resources.

Contact details for oil spill response agencies, organisations and key contractors are available in the VOGA Emergency Contact List (VOG-2000-RD-0050) and further contractors and service provider details is maintained on an Oil Spill Contracts List spreadsheet managed by the VOGA Logistics team.

Table 7-7 lists the spill response resource arrangements, in alphabetical order, that VOGA has in place across the business that may be called on to assist in a VOGA-led spill response.

Oil spill response organisation and contractor capability is confirmed through the assurance and capability management process detailed in Section 7.10.7.

Level 3 Response Support

Managing a Level 3 response to an oil spill will require considerable quantities of resources to be dispatched to the affected areas. Requirements and resources for labour hire, staging areas, accommodation and transport have been considered and arrangements put in place.

Oil spill response operations may extend from Dampier to Broome and offshore including Montebello Islands, Barrow Island and the Dampier Archipelago. VOGA has arrangements in place to accommodate and support the welfare of personnel working offshore and onshore in response activities

Oil spill equipment will usually be moved to the response site or staging area by road, but may also be moved by vessel or air. The vehicle-accessibility of the destination, time to transport the equipment to its destination and the means of unloading the equipment has been considered.

VOGA have a contract with a logistics company to provide supply base and logistical services in the event of an oil spill. These arrangements include the provision of transport and drivers, supply base areas and equipment, waste disposal equipment and laydown areas, mechanical equipment, and emergency accommodation camps for remote deployment of personnel on an island or along remote sections of the WA mainland.

Support organisations and contractor equipment can be deployed to the logistics contractor yard in Dampier, who will appoint a staging area manager to log the delivery of equipment and the deployment of equipment from the stockpile. Alternative staging areas and overflow is available in Dampier.

VOGA plans on establishing an initial staging area in Dampier from which response activities can be organised and deployed including briefing team members, distribution of equipment and PPE, and monitoring of resources.

Additional staging areas for oiled wildlife and shoreline clean-up operations may also need to be set up depending on the spill trajectory. Sites may be identified through the development of Tactical Plans for shoreline response activities and are expected to be required in the Dampier region initially.

Accommodation is required for the following key groups of personnel:

- Emergency response coordination based in Dampier Port/surrounds
- Emergency response personnel deploying equipment at sea based out of Dampier and Exmouth
- Shoreline clean-up crews ranging from North West Cape to Broome.

Personnel for shoreline cleanup are available via labour hire contractors. Contractors have access to a work force suitable for labour intensive shoreline cleanup activities. Large numbers of suitable personnel are available primarily from Perth within the time required for the peak shoreline cleanup phase. Trained team leaders sourced from oil spill response organisations will

be able to undertake inductions that VOGA has prepared for shoreline and oiled wildlife personnel on their arrival.

AMOS Core Group has around 50-70 field operators. Within the field operators section, there is capacity to expand out a response based on the in-company trained supervisory skills of many of the field operators.

Accommodation will be focus on Karratha/Dampier and Exmouth location. VOGA also has arrangements for a contractor to provide emergency camp accommodation for remote deployment of personnel on island. Initial accommodation for the Environmental Pre-Impact Survey and Shoreline spill teams will be provide by the support vessels.

Accommodation can also be sourced onshore through camp providers that supply accommodation and catering. Where camping on islands is not possible, vessels or flotels may be used to accommodate teams working offshore.

The road transport of personnel to onshore locations can be provided by local businesses or to remote locations via contracted and opportunistic vessel providers.

Road transport of personnel will be by hire cars (small teams) and charter buses for large movements of teams such as shoreline responders. Providers are available in Karratha for more immediate use, that can be supplemented from the wider region within the 10 to 20 days required for the peak shoreline clean up phase.



Table 7-7: Key Resource Arrangements Summary

Organisation	Services
Aerial surveillance contractors	Aerial logistical support for aerial surveillance and spill assessment. Additional aviation support may be provided through AMSA
Airstrip	The primary air base option is Karratha International Airport
AMOSC	Staffed 24/7 Duty Officer support; <ul style="list-style-type: none"> • AMOSC Staff availability – 8 staff provided at best endeavours within 3 hours and guaranteed onsite (terrestrially) within 12 hours as per SLA • Equipment availability per monthly status reporting at; http://amosc.com.au/member-login/ & performance indicators as per AMOSC website • Core Group availability per monthly reporting status at http://amosc.com.au/member-login/ includes; <ul style="list-style-type: none"> ○ The Core Group has around 5-10 Incident Control Advisers, 30-40 Incident Management Team personnel and 50-70 field operators ○ AMOSC Oiled Wildlife Team ○ Aerial observers • Mutual aid for equipment at http://amosc.com.au/member-login/ • Access to the National Plan via AMSA within 1 hour on a 24/7 basis • Access to the Fixed Wing Aerial Dispersant capability within 1 hour on a 24/7 basis (includes air attack supervisors) • Access to RPS Trajectory Modelling within 60 minutes • Access to KSAT Satellite imagery within 60 minutes of notification – imagery to be determined at the time of request will dictate supply timeframes depending on satellite availability
AMSA	AMSA manage the National Plan and can provide both oil spill response equipment and personnel as appropriate to the required level. AMSA’s full inventory of equipment can be found at https://amsa-forms.nogginoca.com/public/equipment.html
Labour hire contractors	Unskilled personnel for shoreline response - 100 people by Day 10 and 1000 by Day 20 are accessible via a number of providers based primarily in Perth.



Organisation	Services
Logistics contractor	<ul style="list-style-type: none"> • Supply base/warehousing • Emergency accommodation/camps for shoreline personnel • Transport (personnel and equipment) • Staging areas • Labour and equipment for shoreline response
Marine contractors	Supply vessels to convey and deploy oil spill equipment.
OSRL	<p>Contracted oil spill response equipment and personnel appropriate to the required level to support response strategy deployment, satellite surveillance and operational monitoring.</p> <p>As a member of OSRL, VOGA has access to OSRL's full range of equipment and is entitled to 50% of the OSRL global stockpile, plus access to the Global Dispersant Stockpile.</p> <p>OSRL's monthly inventory of equipment can be found at https://www.oilspillresponse.com/activate-us/equipment-stockpile-status-report</p>
OSMP contractors	Deliver the activated OMPs and SMPs for the duration of a spill event in accordance with the OSMP (WAN-2000-RD-0001.03). Services include operational readiness to enable fast deployment of personnel and resources during a response.
RPS Group	<p>Spill modelling to determine real-time predictions at the time of the spill. The spill trajectory and probability information is used in planning and implementing response options.</p> <p>VOGA has an agreement in place with RPS to allow rapid marine hydrocarbon spill modelling capability to be activated at any time during activities, which will be undertaken for any spill greater than Level 1. AMOSC can also run modelling on behalf of VOGA, if required, as part of contracting arrangements with RPS.</p>
Source control specialist contractors	<p>Relief well planning and operations</p> <p>Dynamic well kill and flow modelling</p> <p>Structural and subsea engineering</p> <p>Subsea inspection and repairs</p>
Waste management contractor	Waste and hazardous waste collection and disposal, including oily water.

7.10.7 Assurance and capability management

VOGA manages oil pollution response capability and assurance requirements through:

- training and competency of key response personnel and contractors;
- assessing and maintaining response capability; and
- assurance tasks such as exercises and third-party inspections.

7.10.7.1 Training and competency

Onsite Emergency Response personnel are trained in emergency control and leadership to ensure they are suitably prepared for decision-making in an emergency situation.

Training requirements are identified for Onsite Command and Incident Command teams to ensure rotate testing of scenarios and equipment. Records are kept to track training of personnel.

Relevant members of VOGA's ICT will have completed incident management training. Full details on ICT personnel training, resource and competency requirements are provided in OPEP Section 5, summary of requirements for VOGA is in Table 7-8. As part of the onsite emergency management requirements the nominated Onsite Commander on Wandoo B (usually the Wandoo Field Superintendent) is required to have PMAOHS511A or suitable equivalent.

Table 7-8: VOGA ICT OSR resource and training requirements

Source and Role	Number required trained in PMAOMIR322 + OSR Training* (or IMO 2)					Number required trained in PMAOMIR418 + OSR* (or IMO 3)				
	Day 1	Day 2	Day 5	Day 10	Day 20	Day 1	Day 2	Day 5	Day 10	Day 20
VOGA Local (total)	7	11	17	17	17	1	2	4	4	4
As directed by DOT	0	3	3	3	3	-	-	-	-	-
Environment Unit Lead	1	1	2	2	2	-	-	-	-	-
Incident Commander	-	-	-	-	-	1	2	4	4	4
Logistics Chief	1	1	2	2	2	-	-	-	-	-
Operations Chief	1	1	2	2	2	-	-	-	-	-
Planning Chief	1	1	2	2	2	-	-	-	-	-
Safety Officer	1	1	2	2	2	-	-	-	-	-
Stakeholder Liaison Officer	1	1	2	2	2	-	-	-	-	-
Finance Chief	-	-	-	-	-	-	-	-	-	-

*Oil Spill Response (OSR) Training

To supplement Incident Management Training, identified ICT members must also complete Oil Spill Response Training. May be completed through participation in a bespoke training program for VOGA, completion of training delivered by AMOSC (or another training provider) or AMSA. Key aspects that must be addressed in this training include:

1. Understand jurisdictional control arrangements;
2. Understand different oil spill response objectives and strategies;
3. Understand the different environmental, sociological and economic considerations of oil spill response;

4. Understand the oil spill incident action planning process; and

5. Understand how to effectively monitor and evaluate oil spill strategies

****ICT Support Roles are Scribe, Safety Officer, Stakeholder LO, Industry LO, Forward Base Lead.**

The Planning Chief is supported by an Environment Unit, with the minimum competency requirement for the Environment Unit Team Leader role being as follows:

- Bachelor's degree in environmental management/ science or equivalent;
- > 5 yrs experience in environmental management;
- PMAOMIR320 or AMOSC IMO 2

Specialised skill sets such as those required for monitoring (e.g. fluorometry, shoreline surveys), aerial observation, OWR and specialised equipment operations will be sourced from the resources available within the AMOSC Core Group, AMSA National Response Team and ESC Network, the DoT State Response Team or service providers.

7.10.7.2 Capability Management

The VOGA Critical Procedure Performance Standard – Oil Spill Response WAN-WNAB-CP-ER-02 and WAN-WNAB-CP-ER-03 (Appendix 5) documents the control measures and performance criteria for oil spill response, with corresponding assurance activities to measure performance.

This includes control measures for ongoing maintenance of response capability (WAN-WNAB-CP-ER-02-01 OSR Arrangements).

Capability can be demonstrated by the creation and testing of mechanisms to access and activate resources during a spill response. These include the testing of contracts, agreements, MOUs, and directories to demonstrate VOGA's capability to implement the response strategies which is undertaken and documented at a minimum of annually under the Oil Spill Response Capability Review [VOG-7000-RH-0009] (refer to Table 7-10 for details). For each Environment Plan revision submitted to NOPSEMA the most current information from the review is provided as part of the ALARP demonstration (see Section 6.2.8).

Determining capability for oil spill response requires an understanding of the strategies to be implemented and the associated resources. Resources required to support the implementation of each response strategy are identified in the OPEP (i.e. OPP2) and demonstrated as suitable in Sections 6.2.6 and 6.2.8 of this EP. VOGA manages ongoing capability required for what it considers to be the highest demand spill scenarios, with the assumption that a capability which applies to worst-case spill scenarios should be sufficient in terms of resource preparedness for less significant spill scenarios.

Capability assessment is a step in the response planning process described in Figure 7-4 and utilised as an ongoing self-assurance and continuous improvement process. Once a capability is defined, arrangements are then tested to ensure it can be achieved and that risks are being managed to ALARP. If testing suggests the capability cannot be achieved, then an assessment of the response strategy and specified capability is undertaken. The following questions are considered to determine capability requirements to support management of risk to ALARP:

- Are there additional tasks that can be undertaken for this strategy?

- When and where the resource would be required, based on the results of consequence modelling (e.g. time to impact, thresholds and probability)?
- How long would the resources be required for use?
- Where and what are the size of stockpiles available to VOGA?
- What are the mobilisation times for equipment from these stockpiles and contractor resources?
- What are the logistical requirements for safe deployment of materials and equipment?
- Is there any benefit of either increasing resource and/or reducing mobilisation times?
- What are the costs of either increasing resource and/or reducing mobilisation times?
- Is there any benefit in increasing the amount of resources?
- Is there a better way to undertake activities associated with this strategy?

If the capability cannot be achieved, then response strategies will be reviewed as part of the IAP process to identify alternative response strategies that reduce risks to ALARP.

In addition to the testing documented in Table 7-9 and the Oil Spill Response Capability Review [VOG-7000-RH-0009], exercises, inspections/audits and action management are undertaken as a key aspect of performance management:

- Exercises - the VOGA Emergency Response Schedule [VOG-1100-YH-0001] addresses the scope and requirements for conducting exercises for the onsite and incident command teams and provides details regarding the reporting of recommendations arising out of exercises including changes of procedure, corrective actions and new guidelines. Table 7-9 presents the exercise schedule.
- Inspections and audits - VOGA's auditing schedule includes all elements of VOGA's HSE MS, including environment performance. The auditing schedule includes three types of auditing processes: Internal inspections of VOGA's response capabilities and commitments; External inspections of VOGA's response capabilities and commitments; and Inspections of third-party providers. The frequency of the inspection is dependent on VOGA's activity, requirements of mutual aid partners and size/capability of the organisation and is provided in. Note that this is in addition to the annual capability testing documented in the Oil Spill Response Capability Review [VOG-7000-RH-0009] and detailed in Table 7-10
- Action management - Recommendations arising out of OSCP reviews, capability reviews, inspections, audits are reviewed and where recommendations are to address an increase spill response risk exposure identifies interim measures to manage the risk to ALARP whilst any agreed action is being completed.



Table 7-9: Testing schedule

Objectives that VOGA will test	Evidence and supporting documentation required	Well Construction activities	Wandoo Field activities	Within three months after a significant change to spill profile	Joint industry, OSRA, or OSRO exercises
		Within three months before activity starts	Annually		
Aim 1: Provide situational experience for core incident command team personnel and enabling them to be aware of their assigned roles and responsibilities during a response					
To provide an oil spill event to test the onsite or incident command team roles specifically listed in Section 5 of the OPEP.	VOGA ICT exercise scenario description and attendance list.	X	X	-	-
	VOGA onsite command team scenario description and exercise report.	-	X	-	-
Aim 2: Assess the effectiveness, achievability and timeliness of incident action planning for the duration of expected response					
Test the incident response cycle as documented in the OSCP.	VOGA ICT exercise scenario description, IAP and decision/event log and post scenario lessons learned.	X	X	X	-
	VOGA onsite command team scenario description and exercise report.	-	X	-	-
Aim 3: Testing interfaces and deployment of equipment and resources					
Test the mobilisation ability and logistic assumptions around equipment and personnel movement, timings and capability as per the OPEP.	ICT member/s observer's role or participates in mobilisation exercise with OSRA or OSRO with lessons learned documented.	-	-	-	X
	Updates to Oil Spill Response Capability Review (refer to Table 7-10 for objectives and scope).	X	X	X	-
To test the VOGA on-site equipment capability.	Maintenance records for simulated deployment of satellite tracking buoy.	-	X	-	-
To assess that the ICT are aware of notification protocols in place to contact other agencies, regulatory authorities and OSRAs and OSROs.	VOGA ICT exercise scenario description, IAPs, decision/event log and stakeholder/notification contact list.	X	X	X	-

VERMILION OIL & GAS AUSTRALIA

Title: Wandoo Facility Environment Plan
 Number: WPA-7000-YH-0007
 Revision: 16
 Date: 21 April 2021



Objectives that VOGA will test	Evidence and supporting documentation required	Well Construction activities	Wandoo Field activities	Within three months after a significant change to spill profile	Joint industry, OSRA, or OSRO exercises
		Within three months before activity starts	Annually		
To participate in equipment deployment exercises (AMOSC, AMSA, DoT, contractors, other industry operators) as observers or ICT members.	ICT member/s observers' role or participates in joint industry exercise: Shore-based equipment field deployment exercise.	-	-	-	X

Table 7-10 Oil Spill Capability Review Scope

Test	Objectives	Parties involved
Source control (Relief well and CGS containment/repair)	To test arrangements (e.g availability of adequate equipment and competent personnel) to undertake source control activities as per the resource requirements defined in Table 6-6 and Table 6-27 of this EP.	VOGA and third party agencies and service providers (refer to EP Table 7-7: Key Resource Arrangements Summary for resource arrangements)
Monitor and evaluate	To test arrangements (e.g availability of adequate equipment and competent personnel) to undertake monitor and evaluate activities as per the resource requirements defined in Table 3-4 of the OPEP (WAN-2000-RD-0001.02)	
Dispersant (Aerial and Marine)	To test arrangements (e.g availability of adequate equipment and competent personnel) to undertake chemical dispersant activities as per the resource requirements defined in Tables 3-6 and 3-7 of the OPEP (WAN-2000-RD-0001.02)	
Mechanical dispersion	To test arrangements (e.g availability of adequate equipment and competent personnel) to undertake mechanical dispersion activities as per the resource requirements defined in Table 3-10 of the OPEP (WAN-2000-RD-0001.02)	
Containment and recovery	To test arrangements (e.g availability of adequate equipment and competent personnel) to undertake containment and recovery activities as per the resource requirements defined in Table 3-12 of the OPEP (WAN-2000-RD-0001.02)	
Protection and deflection	To test arrangements (e.g availability of adequate equipment and competent personnel) to undertake protection and deflection activities as per the resource requirements defined in Table 3-14 of the OPEP (WAN-2000-RD-0001.02)	
Shoreline response/cleanup (includes staging areas and accommodation)	To test arrangements (e.g availability of adequate equipment and competent personnel) to undertake shoreline response/cleanup activities as per the resource requirements defined in Table 3-16 of the OPEP (WAN-2000-RD-0001.02)	
Oiled wildlife	To test arrangements (e.g availability of adequate equipment and competent personnel) to undertake oiled wildlife activities as per the resource requirements defined in Table 3-20 of the OPEP (WAN-2000-RD-0001.02)	
Operational and scientific monitoring (OSMP)	To test arrangements (e.g availability of adequate equipment and competent personnel) to undertake OSMP activities as per the resource requirements defined in Tables 10-2 and 10-3 of the OSMP (WAN-2000-RD-0001.03) (Appendix D of OPEP)	

Test	Objectives	Parties involved
Waste management	To test arrangements (e.g availability of adequate equipment and competent personnel) to undertake waste management activities as per the waste volume requirements defined in Section 6.8 of the OPEP (WAN-2000-RD-0001.02)	
Incident Command Team	Test availability of competent personnel to staff the VOGA ICT as per the resource requirements defined in Table 5-1 of the OPEP (WAN-2000-RD-0001.02)	

Table 7-11 Inspection frequency and scope

Item	Third Party oil spill response providers				
	Oil Spill Response Organisations	Key OSMP provider	OWR Agency	Local/Regional Oil Spill Equipment Provider	Global dispersant
Frequency	3-yearly	3-yearly	3-yearly	2-yearly	3-yearly
Equipment: Maintenance management, logistics, training, readiness for activation/deployment.	Included	Included	Included	Included	Included
People: training and competency management, quantity and availability.	Included	Included	Included	Included	-
Activation Process: Notification processes, activation and mobilisation of people and equipment, exercises and testing.	Included	Included	Included	Included	Included
Documentation: Contracts, agreements, specialist services, authorisation lists, capturing of learning and input into training materials.	Included	Included	Included	-	Included
Management and organisation: Organisational management of change process, lessons learnt, contracts and liability.	Included	-	-	-	-

7.10.7.3 COVID-19 impact on response capability

As part of the VOGA COVID-19 Management Plan, Vermilion monitors the impacts the pandemic and government restrictions (including international and interstate borders) have on emergency response capability. Vermilion will continue to monitor the situation and where oil spill response capability is significantly altered and a review of the OSR Capability Review [VOG-7000-RH-0009] is required as per Table 7-10.

7.10.7.4 Continuous improvement

The OSCP requires review:

- following a significant change to a spill risk profile;
- following significant changes to OSR capability or performance standards; and
- post-significant event (i.e. incident, change to risk profile, change to activities, change to preparedness/capability both within VOGA and external service providers).

Reviews will consider any issues arising from events or exercises, any changes in legislation, and also incorporate findings and recommendations from industry incidents locally and globally (if and when information is made public).

Recommendations arising out of OSCP reviews, capability reviews, inspections, audits are reviewed, assessed and considered for implementation if it is consistent with the ALARP principles outlined in the VOGA EPs. A schedule of reviews is provided in Table 7-12.

Table 7-12 Review schedule

Objective	Activity type	Wandoo Facility Operations			
		Annually	After significant changes to OSR capability	After a significant change to spill profile	Post-significant event
To ensure response capability is maintained	Review OSR Capability Review [VOG-7000-RH-0009] (refer Table 7-10)	X	X	X	X
To ensure response strategies are consistent with oil spill mitigation requirements	OSCP review	-	X	X	X

7.11 Chemical assessment process

VOGA has a chemical assessment and selection process to manage the risks and impacts associated with discharge of chemicals to the marine environment to ALARP during operations.

VOGA uses the chemical ranking scheme developed through the OSPAR Commission decision 2000/2 and the OSPAR list of substances considered to PLONOR to the environment to determine the risk of discharge of chemicals to the environment in order to select the lowest toxicity chemicals practicable.

Under the OSPAR list, chemicals are ranked using the CHARM model. The CHARM model calculates the ratio of Predicted Effect Concentration against Predicted No Effect Concentration (PEC:PNEC). This is expressed as a HQ, which is then used to rank the product. HQ is converted to a colour banding to denote its environmental hazard (refer to Table 7-13) which is then published on the Definitive Ranked Lists of Approved Products by the OCNS.

Products not applicable to the CHARM model (i.e. inorganic substances, hydraulic fluids or chemicals used only in pipelines) are assigned an OCNS grouping, A-E. Group A includes products considered to have the greatest potential environmental hazard and Group E the least.

Any chemical that will be discharged to the marine environment during operations activities shall meet at least one of the following criteria:

- The chemical is listed on the OSPAR List of Substances Used and Discharged Offshore which are considered to PLONOR; or
- The chemical has a HQ banding of Gold or Silver or an OCNS grouping of E or D in accordance with the OCNS Definitive Ranked List of Registered Substances.

If the chemical is not OCNS listed the ecotoxicity data will be assessed in accordance with the OCNS system. The OCNS system requires bioaccumulation, biodegradation and aquatic toxicity data from relevant species such as algae, crustacea or fish to be assessed. Once appropriate ecotoxicity values are obtained they will be evaluated against the OCNS grouping data.

An ALARP justification is required for any chemicals not OCNS listed, if listed with a substitution warning, if there is no available ecotoxicity data, or if ecotoxicity is available but:

- LC50 <10 mg/l or EC50 <10 mg/l;
- the bioaccumulation octanol-water partition coefficient (log Pow)>3; or
- the percentage biodegradation within 28 days is <20%.

The ALARP justification assesses the chemical requiring approval and available alternative options in accordance with the following factors (in order of priority):

- Health and safety criteria (Dangerous Goods Class and Safe Work Australia risk phases);
- Ecotoxicity criteria (aquatic toxicity, bioaccumulation and biodegradation data for relevant species);
- Effectiveness on Wandoo process; and
- Cost.

The change of chemical will be risk assessed and documented in a MOC in accordance with process outlined in Section 7.8.

Table 7-13: OCNS HQ and colour bands

Minimum HQ value	Maximum HQ value	Colour banding	
>0	<1	Gold	Lowest hazard
≥1	<30	Silver	
≥30	<100	White	
≥100	<300	Blue	
≥300	<1000	Orange	
≥1000		Purple	Highest hazard

7.12 Biofouling risk assessment process

The biofouling risk assessment process is undertaken as part of the process for engaging a new Contractor for activities involving vessel, MODU and/or immersible equipment, or for the mobilisation of a previously contracted vessel known to have an increased risk profile since last use (e.g. extended period in Port).

The process excludes ballast water management (managed under the Biosecurity Act 2015, Australian Ballast Water Management Requirements (DAWR, 2017) consistent with the International Convention for the Control and Management of Ships' Ballast Water and Sediments (Ballast Water Management Convention).

The following steps outline the VOGA Biofouling Risk Assessment Process:

Step 1: Conduct Review of Relevant Contractor Procedures and Documentation:

- Biofouling Management Plan consistent with IMO guidelines;
- Biofouling Record Book;
- Antifouling Coating Certificate; and
- Immersible equipment management procedures.

Step 2: Conduct Biosecurity Risk Assessment (vessel, MODU and/or immersible equipment) *

- Gather relevant information (where available);
- Recent inspection(s) – date / location and any corrective actions taken;
- Dry dock / cleaning information – date / location;
- Operational History (e.g., operating out of areas with known IMS);
- Anti-fouling coatings (AFC) – valid, age, coverage, appropriate for vessel activity profile;
- Maintenance and inspection records and biocide dosing information for Marine Growth Prevention Systems (MGPS);
- Vessel operating profile – including any details of vessel operating outside normal profile, extended inactive periods;
- Vessel previously located in high risk area (vessel sharing with other high or uncertain risk conveyance / platform, ports with established IMS.);
- Immersible equipment activity profile and history;
- Immersible equipment cleaning, drying, maintenance and storage practices;
- planned activity profile for vessel / MODU immersible equipment – how long alongside, proximity to facilities;
- The Western Australian Department of Primary Industries and Regional Development 'Vessel Check' may be used to validate the low risk status of commercial vessels frequenting Western Australian waters; and
- Assess risk using the VOGA Risk Management Manual [VOG-2000-MN-0001] based on biofouling risk indicators from The Western Australian Department of Primary Industries and Regional Development 'Vessel Check'. Risk indicators will include the following:

- History of the vessel/facility, including time spent in ports of call since last dry dock, cleaning regime or marine pest inspection results
- Time between a biofouling inspection and mobilisation to an offshore activity to inform exposure risk following the last inspection and justify the relevance of biofouling inspection findings
- Presence of an appropriate biofouling management plan and effective implementation of the plan
- Level of existing biofouling and the presence of species of concern (in particular the presence of marine pests) within biofouling communities on the vessel/ infrastructure/ facility associated with the activity (informed by biofouling record books, maintenance records, cleaning results or inspection programs)
- Operational profile relevant to biosecurity risk such as operating speed, time alongside a facility and the need for ballast exchanges while engaged in an offshore activity

Step 3: Further Risk Mitigation Actions

If a low risk is not identified, an IMS expert will be engaged to review risk assessment and recommend mitigation measures to implement for the vessel risk to be acceptable. Further information must be obtained, and action undertaken to reduce risks to an acceptable level (i.e. low risk or further risk mitigation actions implemented) prior to proceeding with engagement of vessel or equipment. Mitigation measures include:

- engage independent IMS expert to conduct visual inspection
- Cleaning of biofouling on submerged surfaces to reduce the risk of marine pest transfer.
- Additional marine growth prevention measures (e.g. dosing of internal seawater system with biocides, application or re-application of anti-foul coatings).
- Using alternative vessels or other mobile components or equipment that have a demonstrated low biosecurity risk profile.

7.13 Monitoring and Review

7.13.1 Auditing

The VOGA audit procedure is outlined in the Performance Assessment Manual [VOG-1000-MN-0003]. The audit process comprises:

- Audit scheduling;
- Preparation and planning;
- The audit;
- Reporting; and
- Follow up and action item close-out.

To support compliance monitoring, the audit plan is set out each year as part of the VOGA Audit Schedule [VOG-2000-RY-0031]. An Environmental Advisor and/or HSE Advisor will undertake environmental audits to ensure compliance with environmental performance outcomes and

performance standards. These audits will be scheduled to occur at least once a year. The audit findings will be outlined in an audit report submitted to the Operations Manager.

A summary of the environmental audit findings will be included in the annual compliance report submitted to NOPSEMA.

Following receipt of the audit report, the Operations Manager should undertake a review and develop an action plan. The action plan should finalise:

- Action items;
- Action parties;
- Timeframe for completing action items; and
- Approver.

The appropriate actions need to be taken by the designated action parties within the agreed timeframe. The process for closing out actions is detailed in the Performance Assessment Manual [VOG-1000-MN-0003].

7.13.2 Environmental monitoring strategy

7.13.2.1 Overview

VOGA has developed an environmental monitoring strategy based on a review of risk and impact levels identified in Section 6 of the EP.

The strategy takes into consideration the following:

- Identification of the area of interest (the EMBA for each hazard);
- Identification of environmental values within this area of interest, and their current condition;
- Identification of the potential environmental impact (the pressure potentially causing an environmental impact); and
- The management response.

The strategy also guides management response by:

- Identifying whether baseline conditions have been adequately defined and quantified;
- Identifying whether additional data is required to assess whether operation of the Facility is having a measurable impact on the offshore environment; and
- Identifying which mitigation or management measures may be required if monitoring identifies a measurable impact.

There are a number of ecologically sensitive receptors such as island nature reserves in the general area of where WNA and WNB operate, but these are some distance away (the nearest, Dampier Archipelago, is 40km away) and are unlikely to be directly affected by VOGA operations at Wandoo unless there is a significant hydrocarbon release.

Given the ecological importance of areas potentially affected by hydrocarbon release (or from an alternate activity that may have been assessed to have the potential to impact the offshore environment), it is important that baseline information regarding the physio-chemical and

ecological condition of the marine environment and any sensitive receptors that reside within the EMBA is readily available. An appropriate level of baseline survey data is also required to ensure that significant impacts on ecological values can be measured and recovery of these values can be monitored and remediated.

In this context, monitoring requirements in consideration of a significant hydrocarbon release are considered in detail within the Wandoo Field OSCP [WAN-2000-RD-0001]. Monitoring requirements in relation to standard operational activities are considered further in this section.

7.13.2.2 Routine environmental monitoring

The routine operation of the Wandoo Facility and accidental events associated with the facility pose a range of different environmental risks. The risks have been comprehensively assessed in Section 6 of this Wandoo Facility EP and a summary of the routine monitoring is as follows:

- Ballast water and PFW discharge (refer to Table 6-44)
- Emissions and discharges (refer to Table 8-1)

7.13.2.3 Field environmental monitoring

In terms of volume and total contaminant loads, the combined ballast and PFW discharge from WNB represents the most significant discharge into the offshore environment from the Wandoo facilities. Discharges of other types of wastewater from the Wandoo Facility are considered minor and are unlikely to be discernible from the overall potential impact of the PFW discharge. Hence, field environmental monitoring is undertaken to primarily assess whether the ballast and PFW discharge has caused any accumulation of contaminants.

A field environmental monitoring campaign was undertaken in 2015 which supported the assumptions for the impact assessment for PFW and validated the dilutions modelling (refer to Section 6.7.4.1 for details).

A field monitoring campaign is proposed to be undertaken within 2021 to assess any long term contamination and any exceedance of the mixing zone boundary in accordance with Section 7.13.2.4.

In addition, an IMS inspection of project infrastructure utilising third party specialists to validate the absence of invasive marine pests will be undertaken within 2021.

7.13.2.4 Future field environmental monitoring

Key sensitivities

Key sensitivities and species are described and considered in Section 4 of this EP. It is confirmed that key environmental assets at risk are species and habitats that primarily occur outside the Operational Area that could be impacted by a significant hydrocarbon release. These are present in both coastal and offshore locations throughout the NWS.

Sensitivities that are closest to the Wandoo facilities are the Dampier Archipelago and the Montebello Islands, located 50km southeast and 40km west of the WNB Platform, respectively. These sensitivities are well beyond the direct influence of the Wandoo operations. The EP also provides a summary of conservational significant marine species that may potentially occur near the Platform.

The risks associated with operation of the Facility on these species are considered very low as these species are likely to be present infrequently and are not resident. The potential exposure to operational discharges is also considered low. Their low relative abundance and mobility also precludes them from being suitable biological indicators for environmental monitoring of operational discharges such as PFW.

Monitoring indicators and studies

Indicators that are suitable for environmental monitoring should be:

- Measurable;
- Relevant with respect to the actual and predicted impact;
- Able to give significant results;
- Have a measurable response within a reasonable time; and
- Cost effective.

Selecting monitoring variables that are difficult to measure, irrelevant, uncertain or extremely costly, are not useful and will not add to knowledge or understanding of impacts associated with operational discharges. Details of proposed monitoring indicators for Wandoo Field are provided in Table 7-14

Table 7-14: Potential monitoring indicators for use at Wandoo

Indicator	Comments
Sediment	Relatively easy to measure using standard methods, e.g. grab. Relevant as particulate hydrocarbons and other contaminants are likely to settle out within 1km of the discharge. Have internal baseline data for comparison. Provide a good basis for determination of cumulative long-term impacts. Relatively rapid testing (weather dependent) and reporting of results (usually within four weeks of testing).
Water	Relatively easy to measure at surface or depth using standard methods, e.g. Van Dorn or equivalent. Have internal and external baseline data for comparison. Provide a poor basis for determination of cumulative long-term impacts. Useful to obtain information to validate the presence of particular contaminants in the water column that could be directly related to the discharge, however the assessment of the PFW discharge itself (as per Table 6-44) is considered more effective and plume identification can be difficult. Relatively rapid testing (weather dependent) and reporting of results (usually within four weeks of testing).

Indicator	Comments
Benthic (infauna)	<p>Relatively easy to measure using standard methods, e.g. Van Veen grab or equivalent.</p> <p>Relevant as represents the habitat most vulnerable to cumulative long-term impacts based on its presence adjacent to WNB.</p> <p>Have internal baseline data for comparison.</p> <p>Relatively rapid testing (weather dependent) however reporting of results is comparatively slow (due to laboratory testing).</p> <p>Significant spatial and temporal variability common. Small scale variability can often confound interpretation of subtle impacts.</p> <p>Is likely to detect a significant impact, if present.</p>
Other benthic habitat (seagrass, corals)	None present and therefore not considered further.
Plankton	<p>Relatively easy to measure using standard methods, e.g. plankton tow nets.</p> <p>Relevant as represents species and habitat most vulnerable to direct impacts from discharge from WNB.</p> <p>Would be reliant on external data for comparison.</p> <p>Massive spatial and temporal variability in abundance and diversity of species related to tide, depth, season and time of day.</p> <p>Interpretation of impact likely to be confounded.</p>
Fish	<p>Comparatively difficult to measure, although a range of methods available e.g. non-destructive BRUVS.</p> <p>Less relevant to impact detection as species are highly mobile and typically non-resident.</p> <p>Would be reliant on external data for comparison although some data is available from previous biochemical studies.</p> <p>Significant spatial and temporal variability in abundance and diversity of species</p> <p>Interpretation of impact likely to be confounded.</p>
Megafauna (reptiles and marine mammals)	<p>Comparatively difficult to measure as species are relatively uncommon and unlikely to occur in sufficient numbers for statistical assessment.</p> <p>Less relevant to impact detection as species are highly mobile and typically non-resident.</p> <p>Would be reliant on external data for comparison although some data is available from anecdotal observation.</p> <p>Significant spatial and temporal variability in abundance and diversity of species</p> <p>Interpretation of impact likely to be confounded.</p>

On the basis of the advantages and disadvantages discussed above, the indicators most useful in determining impacts related to operational discharges and long-term cumulative impacts are related to assessment of benthic parameters, primarily sediment quality and possibly infauna. In addition to this, water quality sampling is proposed to be undertaken to verify that key parameters are not exceeded outside of the defined mixing zone boundary.

Monthly and annual PFW composition analysis is undertaken to collect PFW composition and toxicity data and compare with thresholds, baseline and historical data to assess changes (Refer to Table 6-44).

Indicative details of proposed field monitoring studies are provided in Table 7-15.

Table 7-15: Indicative details of future field marine monitoring

Survey	Objective	Parameters
Sediment quality	Collect sediment quality data and compare with ANZECC guideline values and historical sediment quality data at the boundary of the mixing zone to assess the mixing zone extent and any long-term changes.	ANZECC/ARMCANZ Sediment Quality Guidelines (2018) low trigger values*: Heavy metals (ie Al, As, Ba, Cd, Cr, Co, Cu, Fe, Hg, Ni, Pb, Zn); NH ₃ ; TRH; PAH; TOC; and Particle Size Distribution.
Benthic infauna and epifauna	Collect infauna data and compare with historical data to assess any long-term changes.	Abundance; Species richness; and Diversity.
Water quality	Collect water quality data and compare with ANZECC guideline values and historical sediment quality data at the boundary of the mixing zone to assess the mixing zone extent and any long-term changes.	ANZECC/ARMCANZ Water Quality Guidelines (2018) 99% species protection values*: Heavy metals (ie Al, As, Ba, Cd, Cr, Co, Cu, Fe, Hg, Ni, Pb, Zn); Ammonia TRH; PAH TOC; and Particle Size Distribution.

**where no guideline is specified for a contaminant of concern, derive a value based on the natural background (reference) concentration multiplied by an appropriate factor as described by ANZECC guidelines.*

7.13.3 Review of the Environment Plan and Oil Spill Contingency Plan

A formal review and revision of the Wandoo Facility EP will be undertaken every five years (Regulation 19), after a significant modification or new stage of an activity, or any new or increased environmental impact or risk has been identified under Regulations 17 or 18.

The review will include an assessment of:

- The compliance with the Commitments Register (containing environmental performance outcomes and standards);
- Any changes to the Wandoo Well Operations Management Plan [VOG-1000-YG-0006] which may impact on well integrity;
- The continued relevance of environmental performance outcomes and standards;
- Effectiveness of the implementation strategy within the Wandoo Field EP; and
- The adequacy of auditing and monitoring.

The review schedule and triggers for the OSCP are outlined in the Wandoo Field OSCP [WAN-2000-RD-0001].

7.13.4 Annual performance review

VOGA undertakes an annual performance review in accordance with Assurance Procedure #03303vai. The scope includes the following:

- Compliance auditing results;
- Operational results summary;
- Reportable and Recordable incidents;
- Oil spill response assurance activities;
- Stakeholder consultation activities; and
- EP and OPEP reviews undertaken.

Key areas of improvement identified and resolved as part of this performance review process since acceptance of Revision 12 of this EP include the following procedures/processes:

- Produced Water Adaptive Management Strategy [WNB-7000-RP-0010]
- Platform Operations Manual Procedure - Measurement and Reporting of Produced Formation and Ballast Water Oil in Water Content (WNB-012-502)
- SPM Marine Facilities Procedures
- Marine Operations Manual
- Wandoo Field Oil Spill Contingency Plan
- Guidelines for visiting WNA Checklist (WNA-014-103)

The number of Reportable environmental incidents has not exceeded two each year since 2017, and the number of Recordable environmental incidents has decreased from 17 in 2017 (primarily OIW monitoring and reporting issues) to 6 and 5 in 2019 and 2020 respectively.

7.14 Management of asset and decommissioning

7.14.1 Asset management

7.14.1.1 Maintenance of property

This section addresses the EP content requirements for Section 572(2) of the OPGGS Act which states that:

“A titleholder must maintain in good condition and repair all structures that are, and all equipment and other property that is:

a. in the title area; and

b. used in connection with the operations authorised by the permit, lease, licence or authority.”

In accordance with Section 572(2), Vermilion manages and maintains the property within the Wandoo Field to economic end of field life through our Asset integrity Management System (AIMS) and maintenance management processes. These mechanisms ensure asset(s) are maintained and monitored to economic end of field life, this also ensures assets will be suitably maintained for decommissioning.

The Asset Integrity Management System, through the AIMS Manuals, ensures that the assets are maintained thus meeting requirements of Section 572(2). The AIMS framework is governed by the following objectives:

- Maintaining the risk to personnel and the environment to ALARP;
- Providing every employee and contractor with a safe and healthy workplace;
- Minimising adverse environmental effects associated with Vermilion's operations; and
- Verifying and checking the effectiveness of hazard control measures.

The AIMS is comprised of the following Asset components

- Pressure (includes risers and flowlines);
- Structural (includes Calm buoy mooring and platform super-structures);
- Well;
- Fire & Safety Systems
- Electrical;
- Communications;
- Rotating Equip.

The inspection, testing and maintenance tasks and frequencies are managed using maintenance procedures within the Enterprise Asset Management (EAM) system. The individual inspection, testing and maintenance procedures describe specific guidelines and the reporting criteria for the related tasks. After completion of each inspection, testing or maintenance task, a record of the actions carried out and the outcomes are recorded in the EAM system. This is then used to verify and measure the integrity of plant equipment and critical items (through comparison with acceptance criteria and KPIs).

A review of historical data related to the integrity management has been undertaken as part of 5-yearly revision of the Safety Case; last undertaken in 2019/20. Data was collected over the prior 5-year period from the following sources:

- Incident and event database, including all recorded incident events & investigations, and near misses, but excluding Hazard Observations: This information was utilised to identify:
 - significant incidents;
 - repeated corrective actions; and
 - trends in failure analysis and/or root causes.
- Deviation Risk Assessments and Operational Directives: DRAs and Operational Directive are utilised to identify system shortfalls which required Operations to implement short term changes to improve or manage safety outcomes;

- Actions arising from audits and NOPSEMA Planned Inspections, including all action items from all historical NOPSEMA Planned Inspections. This information was utilised to identify and trend areas of improvement for critical elements (CEs) or AIMS discipline; and
- Management of Change / Field Change Approvals (FCAs), FCAs data was reviewed to identify where VOGA have made system improvements as well as identifying trends in short term corrective changes required to maintain integrity/performance of CEs.

Vermilion maintains an asset register which contains assets list for items within the Wandoo Field (WA-14L) and components on facilities and calm buoy. The asset list will be updated to reflect changes to the facility which introduces new equipment (e.g. Well Construction). The list of equipment on the register is provided in Section 2.9.4.

7.14.1.2 Life extension

VOGA intends to operate and maintain the Wandoo Oil Facilities to end of field life. The scope for the Life Extension revisits the design load and resistance criteria using updated loading knowledge and appropriate modern standards, together with information about the condition of the equipment and structures based on inspection records. Independent verification of platform systems supports the life extension process.

The life extension scope ensures key infrastructure is technically suitable for service to the projected life and includes following items:

- WNB Topsides Structures/ WNB Substructure/ Marine Systems/ WNA Topsides and Substructure;
- Subsea Systems / WNB Safety Systems;
- Wandoo wells;
- WNB Process Pressure Plant and Other Topsides.

7.14.2 Managing decommissioning strategy

VOGA currently manages our decommissioning strategy in accordance with Vermilion Corporate's requirements for Asset Retirement Obligations. It is a Corporate expectation that business units manage the decommissioning strategy. The strategies are reviewed by senior management and executive on a 5-yrly basis. VOGA does not plan to undertake any decommissioning activities within the 5-year duration of this current EP.

VOGA recognises that full removal of property listed in Section 2.9.4 is the 'base case' under the current Regulatory framework and any deviation from the base case should demonstrate that a deviation delivers equal or better environmental outcomes compared to the 'base case'.

Vermilion is currently working through formalising a decommissioning strategy. The document will align with the requirements in force under applicable Australian Law; including but not limited to OPGGS Act and Regulations and Environment Protection (Sea Dumping) Act 1981.

Formalising the decommissioning strategy involves:

- Technical and engineering assessment of base case and alternatives options;
- Establishing decision making criteria, including short- and long-term environment performance objectives;

- Multi criteria decision analysis which considers environmental performance objectives and outcomes;
- Framework for engaging relevant stakeholders;
- Identifying knowledge gaps and plans for future investigation/assessment to support decommissioning strategy;
- Identifying action plans to ensure asset is maintained suitable for possible decommissioning activities for example;
- Process for ongoing review and adjust scope to address any Australian specific decommissioning guidelines/requirements;

VOGA anticipate the work to be completed by Q2 2022. Should the decommissioning strategy recommend an alternative to full removal, VOGA will review and discuss deviation approval processes with the applicable Statutory Bodies, including NOPSEMA. To inform VOGA's decommissioning strategy, Vermilion has supported third party research projects through the National Decommissioning Research Initiative and asset specific investigations with University of Western Australia (Marine Futures Laboratory). These projects are scientifically independent studies and where appropriate peer reviewed.

The NDRI program, supported by Vermilion and seven other industry peers, seeks to improve understanding of how full removal or potential decommissioning in-situ may impact on the marine environment. The first two focus areas for the program are:

- Potential impact of decommissioning O&G structures on life in the marine environment; and
- Potential contaminants released in the marine environment if structures remain in-situ.

Current focus areas for Wandoo asset specific programs are:

- Determine the change in fish abundance, species richness and assemblage structure with depth on the Wandoo platforms; and
- Compare the abundance, biomass and diversity of fish and sharks in proximity to Wandoo platforms with surrounding natural habitats.

8. Reporting

8.1 Routine reports

8.1.1 Statutory reporting

Regulations 14 and 15 of the OPGGS(E)R require titleholders to include arrangements in the EP for:

- Maintaining a quantitative record of emissions and discharges to the air, marine, seabed and sub-seabed environment to enable evaluation of performance against performance standards and measurement criteria;
- Recording, monitoring and reporting information about the activity (including information required to be recorded under the OPGGSA, the regulations and any other environmental legislation applying to the activity) sufficient to enable the Regulator to determine whether the environmental performance outcomes and standards in the EP are met; and
- Reporting to the Regulator at intervals agreed with the Regulator, but not less than annually.

Specific monitoring and recording requirements for relevant parameters are detailed in Table 8-1.

Table 8-1: Statutory reporting requirements

Parameter	Reporting requirement and KPI	Responsibility
Records of ballasting and biofouling	Bilge and ballast records. Quarantine inspection compliance records.	Vessel Master and VOGA Field Superintendent
Records of complaints from fishermen or other users	Radio logs document interactions with other sea users.	VOGA Field Superintendent
Records of breaches of restriction zone by fishermen or other	Record of breaches.	VOGA Field Superintendent
OIW discharges from Facility	Wandoo Daily Report.	VOGA Field Superintendent
Solid waste logs (transfers from facility to shore)	Waste manifests.	VOGA Field Superintendent
Atmospheric emissions	Wandoo Daily Report.	VOGA Field Superintendent
Other non-quantitative criteria specified in the measurement criteria	Audit reports including records of any non-compliance with stated objectives.	VOGA HSE Manager
Incident reporting	Incident reports.	VOGA Field Superintendent
Consultation	Consultation records. Complaints register.	VOGA Environment Advisor
Spill response	Spill logs as per IAP (OSCP).	VOGA Environment Advisor

VOGA has legal obligations under the OPGGS(E)R to submit routine reports to NOPSEMA as well as notify NOPSEMA of an incident within a specified period, depending on the impact or potential impact to the environment and whether the incident is deemed reportable or recordable under the regulations.

In addition, VOGA must notify NOPSEMA of a change in the following in accordance with Regulation 15(3):

- The titleholder of WA-14L;
- Titleholder's nominated liaison person; and
- Change in contact details for either the title holder or the liaison person

8.1.2 Routine internal reporting

Routine internal reports will be prepared during operations. These include:

- Daily reports;
- Annual reporting; and
- Routine reporting and review of performance standards

8.1.3 Routine external reporting

VOGA reports information on environmental performance to regulators as outlined in Table 8-2.

Table 8-2: External routine reporting requirements

Report	Recipient	Frequency	Content
Annual EP Compliance Report	NOPSEMA	Annual (calendar year), by 28 February each year.	Review of compliance with environmental Performance Standards in the previous calendar year.
Monthly Recordable Incident Reports	NOPSEMA	Monthly, by 15th of each month.	Details of recordable incidents that have occurred during drilling activities (if applicable).
NPI Report	Department of Environment Regulation	Annual, by 30 September each year.	Summary of the emissions to land, air and water for operational activities for inclusion in the Commonwealth NPI database. Reporting period from 1 July to 30 June.
NGERS Report	Australian Government Clean Energy Regulator	Annual, by 31 October each year.	Summary of the emissions to land, air and water for operational activities. Reporting period from 1 July to 30 June.
Change of titleholder details	NOPSEMA	When change occurs.	Change of titleholder, titleholder's nominated liaison person or a change in the contact details for either the titleholder or the liaison person.

8.2 Internal incident reporting

The Wandoo Event Management Manual [VOG-2000-MN-0003] outlines the reporting requirements:

- Incidents: All incidents that result in a loss must be reported using an approved Incident Investigation Report Form (e.g. injuries, damage to assets, spills and releases, corporate reputation and near misses);
- Non-compliance incidents: VOGA's Incident Report Form must be completed and submitted, whenever a non-compliance event is reported to a regulator;
- Regulatory audits and inspections: The results of all regulatory audits and inspections are to be reported by site supervisors;
- Hazard alert/near-miss reports: It is expected that all near-misses are reported, and all high-potential hazards are investigated and reported, using the Incident Report Form;
- Hazard observations: To encourage the reporting of near-misses, VOGA uses a simplified reporting form. It is expected that all high-potential hazard alerts and close calls will be investigated, and reported, using VOGA's Unsafe act/condition Report Form; and
- Public concerns and complaints: Incidents involving the public in the communities near VOGA operations should be treated as serious and reported using the Incident Report Form.

All near-misses, hazard identifications, incidents, regulatory compliance inspections, and associated action items, must be entered into VOGA's event tracking system within 72 hours of the occurrence. All incident investigation reports must be complete within five working days of the event.

In accordance with the Wandoo Event Management Manual [VOG-2000-MN-0003], all incidents should be immediately recorded within the Event Management Database.

8.3 External incident reporting

8.3.1 Reportable incidents

The OPGGS(E)R defines a reportable incident "as an incident relating to the activity that has caused, or has the potential to cause, moderate to significant environmental damage."

Reportable incidents are identified through the risk assessment process for a reported event and comprise any event with a potential consequence to an ecosystem or environmental asset of 3 (moderate) or greater, i.e. 4 (major) and 5 (catastrophic), regardless of the overall risk level assigned. The consequence ratings are based on VOGA Risk Management Manual [VOG-2000-MN-0001] corporate risk matrix using the ecosystem/environmental asset impact criteria.

For Wandoo Facility Operations, these include:

- Liquid hydrocarbon release from wells;
- Liquid hydrocarbon release from export equipment, submarine hose, floating hose or export flow lines;
- Liquid hydrocarbon release from CGS;

- Vessel collision resulting in diesel spill to sea; and
- Introduction of invasive marine species.

NOPSEMA, NOPTA and the Department of the responsible State Minister are to be notified of all reportable incidents in accordance with the following requirements of the OPGGS(E)R:

- Notify NOPSEMA orally of a reportable environmental incident as soon as practicable but not later than two (2) hours after the first occurrence of the incident or after the time that the titleholder becomes aware of the incident.
- Provide a written record of the notification to NOPSEMA, the Titles Administrator and the Department of the responsible State or Northern Territory Minister as soon as practicable after the oral notification.
- Provide NOPSEMA a written report of a reportable incident as soon as practicable but not later than three (3) days after the first occurrence of the incident.
- Provide a copy of the written report to both the Titles Administrator and the Department of the responsible State Minister within seven (7) days of giving the written report to NOPSEMA.

The written report must contain the following information:

- all material facts and circumstances concerning the reportable incident that the titleholder knows or is able, by reasonable search or enquiry, to find out; and
- any action taken to avoid or mitigate any adverse environment impacts of the reportable incident; and
- the corrective action that has been taken, or is proposed to be taken, to stop, control or remedy the reportable incident.

8.3.2 Recordable incidents

The OPGGS(E)R defines a recordable incident “as an incident arising from the titleholder’s activities that breaches a performance outcome or standard in the EP that applies to the activity and is not a reportable incident”. Recordable incidents are reported to NOPSEMA on a monthly basis.

Written reports of all recordable incidents will be reported to NOPSEMA in compliance with Regulation 26(B) of the OPGGS(E)R and will:

- Relate to a calendar month;
- Be given as soon as practical after the end of the calendar month, and not later than 15 days after the end of the calendar month; and
- Will contain all the information as required under Regulation 26(B) of the OPGGS(E)R.

8.3.3 Management of non-conformances

Non-conformances include near-misses, incidents or other events or information which indicates a lack of conformance with specified objectives or compliance requirements.

VOGA utilises the Vermilion global event recording and action tracking system. This system is used for capturing and following up on near-misses and incidents including their associated corrective

and preventive actions, ensuring that any lessons are learned in the interests of continual improvement.

In addition, and on behalf of the VOGA Managing Director, the VOGA Administration Assistant maintains logs of outstanding actions arising from audits or other actions that do not require entry in event recording and action tracking system, but which nevertheless require some form of follow-up action and confirmation of closure.

9. Stakeholder consultation

9.1 Introduction

For the activity defined in this EP, Regulations 11A, 14(9) and 16(B) of the OPGGS(E)R require consultation with relevant authorities, persons and organisations. VOGA has conducted an extensive range of consultation during the development of this EP and during the development of the Well Construction EP [WPA-7000-YH-0001] from 2012. VOGA is committed to continuing to consult with appropriate stakeholders to ensure concerns associated with the company's activities are mitigated through the management of the activity where practicable.

9.2 Objectives

The key objectives of VOGA's stakeholder consultation process are to:

- Initiate and maintain open communications between stakeholders and VOGA;
- Ensure stakeholders are kept informed of VOGA's activities;
- Provide stakeholders with an opportunity to provide feedback on VOGA's activities;
- Establish an open and transparent process for engagement;
- Manage any concerns raised by stakeholders regarding VOGA's activities; and
- Provide a means for recording all communication and/or consultation, issues raised and responses.

9.3 Stakeholder identification and classification

9.3.1 Overview

Regulation 14(9) of the OPGGS(E)R specifies a requirement for consultation with relevant authorities of the Commonwealth, State, and other relevant interested persons or organisations. Stakeholders associated with VOGA's activities were identified by:

- Reviewing records of previous stakeholder consultation undertaken;
- Engaging with government and non-government organisations, as well as commercial fishing operators licensed/administered through DPIRD;
- Workshop sessions with both internal and external parties, including regulators; and
- Review of the regional context in which VOGA operates and the EMBA associated with the activity to identify which, if any, persons or organisations may be affected by the activities, including oil spill response.

9.3.2 Relevant Stakeholders

In identifying relevant persons to be consulted on the proposed petroleum activity, VOGA prescribes to the definition provided under sub-regulation 11A(1) of the OPGGS (E) Regulations, being:

- a) each Department or agency of the Commonwealth to which the activities to be carried out under the environment plan, or the revision of the environment plan, may be relevant
- b) each Department or agency of a State or the Northern Territory to which the activities to be carried out under the environment plan, or the revision of the environment plan, may be relevant
- c) the Department of the responsible State Minister, or the responsible Northern Territory Minister
- d) a person or organisation whose functions, interests or activities may be affected by the activities to be carried out under the environment plan, or the revision of the environment plan
- e) any other person or organisation that the titleholder considers relevant.

When identifying relevant persons, VOGA considers which stakeholders perform a function in the relation to – or have a function, activity or interest that may be impacted by – the planned, physical petroleum activity. The planned activity for this EP is the Wandoo Facility operations, located in Commonwealth waters. Therefore, in determining who is a relevant person for engagement on the petroleum activity, VOGA sought to identify and engage with stakeholders whose functions, interests or activities could be affected by operations.

Table 9-1 outlines the relevant stakeholder groups, identified stakeholders, and the engagement approach taken.

9.3.2.1 *Unplanned event (emergency conditions) stakeholders*

VOGA undertakes a more targeted approach to consultation with stakeholders in relation to unplanned emergency conditions.

Stakeholders who may perform a function in VOGA planning for, or management of an unplanned activity, and whose information is integral to the development of those management plans, are considered relevant and are engaged during the development of the EP and OSCP.

Stakeholders whose functions, interests or activities otherwise overlap the Hydrocarbon Area or EMBA are not considered relevant to the planned activity and so not engaged during the development of those plans but may be engaged in the event of an unplanned emergency condition. This approach has been adopted to reduce consultation fatigue for stakeholders who will not be impacted by the (physical) petroleum activity.

9.3.2.2 *Commercial Fishery stakeholders*

In addition to the process outlined above for planned activities and unplanned events, identification of relevant commercial fishing stakeholders distinguishes between:

- fisheries with legal boundaries that overlap the Operational Area and have active operations in the vicinity; and

- fisheries with legal boundaries and have active operations that overlap the Hydrocarbon Area and EMBA but not the location of the Wandoo facility (Operational Area).

To minimise stakeholder fatigue, VOGA restricted stakeholder engagement to licence holders in fisheries with legal boundaries that overlap the Operational Area. VOGA also considered if and where licence holders are active (or potentially active) within a fishery to assess whether that licence holder should be engaged.

Table 9-1: Stakeholder mapping

Stakeholder Group	Stakeholder	Relevance and engagement approach
State Government	Department of Mines, Industry Regulation and Safety (DMIRS)	Relevant Directly consulted
	WA Department of Primary Industries and Regional Development (DPIRD)	Relevant Directly consulted
	Department of Transport – Marine Safety	Relevant Directly consulted
	Department of Biodiversity, Conservation and Attractions (DBCA)	Relevant Directly consulted
Commonwealth	Director of National Parks	Relevant Directly consulted
	Australian Maritime Safety Authority (AMSA)	Relevant Directly consulted
	Australian Fisheries Management Authority (AFMA)	Relevant Directly consulted
Fishery Associations	Commonwealth Fisheries Association (CFA)	Relevant Directly consulted
	Western Australian Fishing Industry Council (WAFIC)	Relevant Directly consulted
	Pearl Producers Association	Relevant Directly consulted
Commercial fisheries overlapping the planned petroleum activity (active)	Mackerel Managed Fishery (Area 2) (WA)	Relevant Directly consulted (individual fishers)
	Pilbara Fish Trawl (Interim) Managed Fishery (WA)	
	Pilbara Line Fishery (WA)	
Commercial Fisheries in the Hydrocarbon Area or EMBA (unplanned event – emergency conditions) (active)	North-West Slope Trawl Fishery (Cth)	Not relevant to planned activity
	Western Deepwater Trawl Fishery (Cth)	Licence holders to be informed in the event of unplanned emergency event
	Western Tuna and Billfish Fishery (Cth)	
	Mackerel Managed Fishery (Areas 1 & 3) (WA)	
	Nickol Bay Prawn Managed Fishery (WA)	
	Mackerel Managed Fishery (WA)	

Stakeholder Group	Stakeholder	Relevance and engagement approach
	Kimberley Mud Crab Fishery (WA)	
	Pilbara Crab Managed Fishery (WA)	
	Onslow Prawn Managed Fishery (WA)	
	Kimberley Gillnet and Barramundi Fishery (WA)	
	Broome Prawn Managed Fishery (WA)	
	Kimberley Prawn Managed Fishery (WA)	
	North Coast Demersal Scalefish Fishery (WA)	
	Exmouth Gulf Prawn Fishery (WA)	
	Gascoyne Demersal Scalefish Fishery (WA)	
	Pearl Oyster Fishery (WA)	
	Beche-de-mer (Sea Cucumber) Fishery (WA)	
	Northern Shark Fishery (WA)	
	West Coast Rock Lobster Managed Fishery (WA)	
	Shark Bay Crab Interim Managed Fishery (WA)	
	Shark Bay Scallop Fishery (WA)	
	Shark Bay Prawn Fishery (WA)	
	Inner Shark Bay Scalefish Fishery (WA)	
	Abrolhos Islands and Mid-West Trawl Limited Entry Fishery (WA)	
	West Coast Demersal Scalefish Interim Managed Fishery (WA)	
	West Coast Deep Sea Crustacean Fishery (WA)	
	Octopus Fishery (WA)	
	West Coast Purse Seine Fishery (All Zones) (WA)	
	Abalone Managed Fishery (WA)	
	Pilbara Trap Managed Fishery (WA)	
Shipping	Australian Hydrographic Office (AHO)	Relevant Directly consulted

Stakeholder Group	Stakeholder	Relevance and engagement approach
	Commonwealth Department of Defence (DoD)	Relevant Directly consulted
Industry (Adjacent Titleholder)	Jade stone Energy	Relevant Directly consulted
Tourism and Recreation	Boating Industry Association WA (BIAWA)	Relevant Directly consulted
	RecFishWest	Relevant Directly consulted
Oil Spill Response	AMOSC	Relevant (to aid in the event of an unplanned emergency event) Directly consulted
	WA Department of Parks and Wildlife	Not relevant to planned activity
	City of Karratha	To be informed in the event of unplanned emergency event
	State Emergency Services (SES) Karratha	To be informed in the event of unplanned emergency event
Other	Australian Petroleum Production and Exploration Association (APPEA)	Relevant Directly consulted
	Pilbara Port Authority	Relevant Directly consulted
	National Offshore Petroleum Titles Administrator (NOPTA)	Relevant Directly consulted

9.4 Stakeholder engagement process and EP update

Feedback is sought from the identified stakeholders on the proposed activity, including the proposed management approach detailed in the EP. Based on the feedback received, VOGA may review relevant controls and update them as required. The stakeholder engagement process is outlined in Figure 9-1: Stakeholder consultation workflow.

For the current EP, consultation information was distributed between 22 May and 3 June 2020 and stakeholders advised the following which enabled a minimum 12-week time period for responses to be provided:

- Queries and comments within 4 weeks of the date of the letter are welcomed; and
- Any feedback received after this will still be reviewed and recorded in our stakeholder register, however, it may not be included in our current submission and will be included in future submissions.

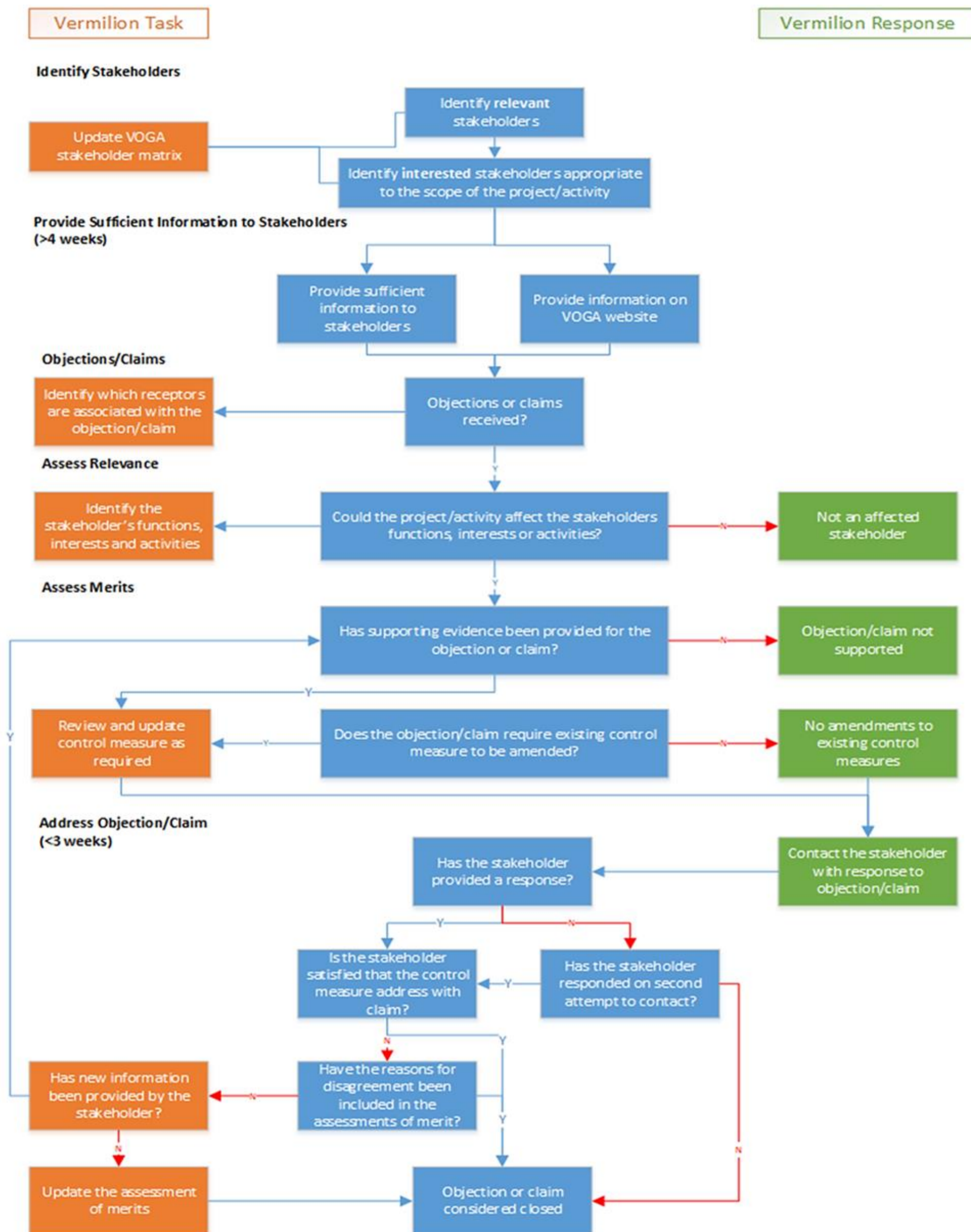

Figure 9-1: Stakeholder consultation workflow

9.5 Summary of stakeholder consultation

9.5.1 Historic stakeholder engagement

During the period November 2013 to June 2014, VOGA engaged with stakeholders by telephone and email, and held briefing meetings (when applicable) to present an overview of its current and planned operations, the Wandoo Field OSCP [WAN-2000-RD-0001] and spill modelling, to seek feedback and comment.

More consultation was undertaken in the period July to December 2016 with WAFIC, DOF (now DPIRD) AFMA, DPaW (now DBCA), Pearl Producers Association and Recfishwest to provide an update on Wandoo activities and review current engagement arrangements with licence holders.

Stakeholders were also engaged prior to the 2015, 2016 and 2018/19 well construction campaigns, as per the Well Construction EP [WPA-7000-YH-0001]. Letters containing information relevant to the Well Construction activities, tailored to each stakeholder category, were issued during November 2019 as part of the 5-yearly review.

Table 9-2 presents a summary of the responses from key stakeholders and the actions by VOGA. A full copy of the VOGA briefing packages, correspondence and full text of the stakeholder replies are held in the VOGA's Document Control System and are available for review on request.

9.5.2 Current stakeholder engagement

Letters and information sheets containing information relevant to the Wandoo facility operational activities (Wandoo Facility EP: WPA-7000-YH-0007) were distributed during May and June 2020

The relevance of the stakeholder objections or claims received to date have been assessed based on their functions, interests and activities and supporting information provided. Appropriate responses to all stakeholders have been provided where required. Table 9-2 provides a summary of stakeholder engagement conducted for this activity.

Full records of stakeholder engagement are provided to NOPSEMA in a separate Sensitive Information Document in accordance with NOPSEMA Environment Plan Assessment Policy (N-04750-PL1347 A662608).



Table 9-2: Stakeholder engagement summary

Stakeholder	Engagement outcome(s) sought	Engagement actions taken	Objections	Key issues raised in consultation to-date	VOGA response to stakeholder feedback	Next steps
			Yes/No/NA			
WA DMIRS (previously DMP)	Provide DMIRS with information and opportunity to comment proposed activities. Notification of well construction activities.	<p>VOGA sent a letter on 27 January 2014 regarding the Wandoo Facility and Well Construction EPs and activities.</p> <p>A mail response from DMP on 11 February requested additional information on the proposed activity.</p> <p>VOGA issued copy of EP summary and covering letter to DMP on 20 February, addressing DMP's information request from 11 February 2014.</p> <p>DMP confirmed via email (on 6 March 2014) that no additional information was required.</p> <p>VOGA sent a letter on 10 August 2015 regarding the 2015 Wandoo Infill Well Construction campaign.</p> <p>DMP confirmed via email (on 21 August 2015) that no additional information was required.</p> <p>VOGA sent a letter on 19 February 2016 regarding the 2016 Wandoo Infill Well Construction campaign.</p> <p>DMP acknowledged the 19 February 2016 letter with a reminder to notify the DMP of commencement and cessation notifications.</p> <p>VOGA sent an email on 22 April 2016 informing the DMP of the commencement of the 2016 well construction activities.</p> <p>DMP acknowledged the commencement email on 20 May 2016 with no comments.</p> <p>VOGA sent an email on 15 June 2016 informing the DMP of the cessation of the 2016 well construction activities.</p> <p>DMP acknowledged the commencement email on 20 July 2016 with no comments.</p> <p>VOGA sent a letter on 1 November 2019 advising that the Well Construction EP was being reviewed to support the statutory requirement for resubmission and acceptance at the end of each period of 5 years, providing relevant activity details and contact details to request further information.</p> <p>VOGA sent a letter and information sheet on 22 May 2020 advising that the Wandoo Facility EP was being reviewed due to proposed process changes, as well as to support a five-yearly resubmission, providing relevant activity details and contact details to request further information.</p>	No	<p>2014 - DMP requested additional information on:</p> <ul style="list-style-type: none"> the activities particularly drilling that is planned; the potential impacts of the activity; spill modelling data; and potential for any impacts to State Waters/coast? <p>2020 – No response to consultation to date.</p>	<p>2014 - VOGA provided the DMP with details on the planned activity; spill modelling data; and the potential impacts of the activities to State Waters and the WA coast.</p> <p>DMP reviewed the notification and in their response did not require any further information.</p> <p>N/A</p>	Continue to keep stakeholders informed during operations.



Stakeholder	Engagement outcome(s) sought	Engagement actions taken	Objections	Key issues raised in consultation to-date	VOGA response to stakeholder feedback	Next steps
			Yes/No/NA			
Pilbara Port Authority	Ongoing DPA participation in exercises. Notification of well construction activities.	VOGA sent a letter on 27 January 2014 regarding the Wandoo Facility and Well Construction EPs and activities. VOGA sent follow-up email on 26 February 2014 giving then Dampier Port Authority (DPA) further opportunity to provide input. VOGA sent a letter on 10 August 2015 regarding the 2015 Wandoo Infill Well Construction campaign. VOGA sent a letter on 19 February 2016 regarding the 2016 Wandoo Infill Well Construction campaign. The Pilbara Port Authority acknowledged the 19 February 2016 letter with no comments	No	No response to consultation to date.	N/A – No feedback received from DPA to date.	Continue to engage through regional spill response activities. Seek DPA participation in VOGA & industry exercises where relevant.
APPEA	Improve collective industry spill response capability through engagement with other APPEA member companies. Notification of well construction activities.	VOGA sent a letter on 27 January 2014 regarding the Wandoo Facility and Well Construction EPs and activities. VOGA followed up during participation in APPEA Safety, Environment and Oil Spill Response forums and through its attendance at twice yearly oil spill planning and capability workshops. VOGA sent a letter on 10 August 2015 regarding the 2015 Wandoo Infill Well Construction campaign. VOGA sent a letter on 19 February 2016 regarding the 2016 Wandoo Infill Well Construction campaign. VOGA sent a letter on 1 November 2019 advising that the Well Construction EP was being reviewed to support the statutory requirement for resubmission and acceptance at the end of each period of 5 years, providing relevant activity details and contact details to request further information. VOGA sent a letter and information sheet on 22 May 2020 advising that the Wandoo Facility EP was being reviewed due to proposed process changes, as well as to support a five-yearly resubmission, providing relevant activity details and contact details to request further information.	No	No issues raised at forums to date.	Review and support actions within the industry on an ongoing basis.	Continued attendance at relevant forums and working groups.



Stakeholder	Engagement outcome(s) sought	Engagement actions taken	Objections	Key issues raised in consultation to-date	VOGA response to stakeholder feedback	Next steps
			Yes/No/NA			
AMOSC	<p>Confirmation of oil spill resources, capability and command as per OSCP.</p> <p>Ongoing AMOSC participation in emergency response/oil spill scenario exercises.</p> <p>Obtain confirmation that AMOSC has a copy of an executed agreement for the provision of emergency response services to VOGA.</p> <p>AMOSC to have opportunity to comment on revised OSCP.</p> <p>Ensure MOU is in place allowing VOGA to access AMOSC equipment.</p> <p>Notification of well construction activities.</p>	<p>VOGA sent a letter on 27 January 2014 regarding the Wandoo Facility and Well Construction EPs and activities.</p> <p>VOGA sent request to AMOSC to provide its spill response resource list on 14 February 2014.</p> <p>AMOSC spill response resource list confirmed as part of OSCP preparations (14 and 20 February 2014).</p> <p>AMOSC issued update to VOGA (and other members) regarding its oiled wildlife response capability in the event of a spill (6 March 2014).</p> <p>VOGA representative participated in an AMOSC Oiled Wildlife Plans Presentation and Discussion Session on 8 July 2014 – to agree that a common WA Oiled Wildlife Response Plan be adopted.</p> <p>VOGA sent a letter on 10 August 2015 regarding the 2015 Wandoo Infill Well Construction campaign.</p> <p>VOGA sent a letter on 1 November 2019 advising that the Well Construction EP was being reviewed to support the statutory requirement for resubmission and acceptance at the end of each period of 5 years, providing relevant activity details and contact details to request further information.</p> <p>VOGA sent a letter and information sheet on 22 May 2020 advising that the Wandoo Facility EP was being reviewed due to proposed process changes, as well as to support a five-yearly resubmission, providing relevant activity details and contact details to request further information.</p> <p>VOGA sought feedback on AMOSC’s response arrangements.</p>	No	<p>On 22 April 2021, AMOSC confirmed that:</p> <ul style="list-style-type: none"> “AMOSC Response Plan is currently in force and will be for the foreseeable future. That plan has AMOSC standing up to a member request and operating remotely/as a standalone unit from VOGA’s or any other IMT. CG personnel in both operational and incident management roles will be under the control (command) of the AMOSC IMT. The AMOSC IMT/operation can be tasked by VOGA to undertake specific or wholesale elements of the response, up to our capacity. AMOSC operations in this fashion rely on provision of logistical support and services from the VOGA IMT, in particular vessels and aircraft. AMOSC’s personnel will be prioritised for use in the AMOSC IMT and operation. Other than a liaison officer stationed at the VOGA IMT, no other staff will be diverted outside the AMOSC structure. Capacity and timelines are as per the AMOSC service level statement, which is available through the AMOSC member company portal website. “ 	<p>Based on AMOSC’s feedback Vermilion reviewed the ICT resource plan and as outlined in Section 7.10.5.2 we have reviewed and are consistent with the AMOSC Response Plan.</p> <p>The aviation, marine and shoreline units in the VOGA ICT resources are reflecting the incident command support that AMOSC provide through their structure. Under the arrangements AMOSC’s IMT will be tasked with these operational coordination functions.</p> <p>Similarly, if AMOSC are tasked with responses within state waters by VOGA, AMOSC IMT would need to provide personnel to interface with DoT as part of their response plan.</p>	<p>Ongoing engagement as required, as outlined in Section 9.5.3- Issue revised OPEP to AMOSC once accepted.</p>



Stakeholder	Engagement outcome(s) sought	Engagement actions taken	Objections	Key issues raised in consultation to-date	VOGA response to stakeholder feedback	Next steps
			Yes/No/NA			
AMSA	<p>Confirmation of oil spill resources, capability and command as outlined in OSCP.</p> <p>Clarify AMOSC and AMSA Memorandum of Understanding (MOU).</p> <p>Confirmation of emergency contacts within AMSA.</p> <p>Confirm AMSA's ongoing participation in emergency response/oil spill scenario exercises.</p> <p>Notification of well construction activities.</p>	<p>VOGA sent a letter on 27 January 2014 regarding the Wandoo Facility and Well Construction EPs and activities.</p> <p>VOGA called and emailed AMSA 31 January 2014 re MOU between AMSA and offshore petroleum operators</p> <p>AMSA clarified arrangements relating to its involvement in an offshore oil spill, as detailed in its industry level MOU.</p> <p>AMSA confirmed industry level MOU has replaced need for individual operator consultation with AMSA.</p> <p>AMSA has provided MOU for VOGA signing and this is being reviewed by VOGA Corporate.</p> <p>VOGA has requested a meeting with AMSA to discuss spill risks from the Wandoo asset and to confirm responsibilities and command transition arrangements for marine spill events under the National Plan – requests issued to AMSA on 18 and 24 February and 27 August 2014.</p> <p>MOU signed by VOGA and sent to AMSA for signature on 15 October 2014.</p> <p>VOGA sent a letter on 10 August 2015 regarding the 2015 Wandoo Infill Well Construction campaign.</p> <p>VOGA sent a letter on 19 February 2016 regarding the 2016 Wandoo Infill Well Construction campaign.</p> <p>VOGA sent a letter on 1 November 2019 advising that the Well Construction EP was being reviewed to support the statutory requirement for resubmission and acceptance at the end of each period of 5 years, providing relevant activity details and contact details to request further information.</p> <p>VOGA sent a letter and information sheet on 22 May 2020 advising that the Wandoo Facility EP was being reviewed due to proposed process changes, as well as to support a five-yearly resubmission, providing relevant activity details and contact details to request further information.</p>	No	No issues raised in consultation to date.	VOGA included AMSA resources and capability as part of OSCP review.	Ongoing engagement as required, as outlined in Section 9.5.3- Issue revised OSCP to AMSA once accepted.
WA DoT	<p>Provide briefing/overview of OSCP.</p> <p>Confirmation of oil spill resources, capability and command with DoT as per OSCP.</p> <p>Confirmation of approval process for dispersant use.</p> <p>Ongoing DoT participation in emergency response/oil spill scenario exercises.</p> <p>Notification of well construction activities.</p>	<p>VOGA sent an email 24 January 2014 requesting a meeting in February to discuss the spill scenarios in the Wandoo Field OSCP.</p> <p>VOGA sent a letter on 27 January 2014 regarding the Wandoo Facility and Well Construction EPs and activities.</p> <p>DoT confirmed WA Government's role in marine oil spill response.</p> <p>DoT confirmed WestPlan Marine Oil Pollution only requires confirmation that an operator's OSCP is aligned with State and National response frameworks.</p> <p>DoT provided information on dispersant quantities and access (14 February 2014) and the dimensions of boom required for single vessel side sweep operations (26 February 2014).</p> <p>Meeting held with DoT on 25 February 2014 regarding oil spill scenarios and response plans. DoT confirmed its role as hazard management agency in the event of a spill and advised no MOU was required to access resources.</p>	No	<p>No issues raised in consultation to date.</p> <p>2019 – DoT thanked VOGA and noted the information provided</p> <p>17 June 2020 – DoT requested a copy of the OSCP to focus on ensuring that the IGN arrangements have been captured given the changes in the last couple of years, noting no change to risk of an oil spill impacting State waters.</p> <p>30 June 2020: DoT provided the following comments on the OSCP:</p>	<p>2014 - VOGA provided a copy of OSCP and confirmed alignment with State and National response frameworks.</p> <p>23 June 2020 – VOGA provided a copy of the OSCP.</p> <p>2 July 2020 – VOGA confirmed the following: The DoT emergency response number is included in the linked emergency contact list, and will consider if and where appropriate to include in the OPEP itself. The recognition of DoT request for POLREP/SITREP following initial notification is</p>	Ongoing engagement as required, as outlined in Section 9.5.3- Issue revised OSCP to DoT once approved.



Stakeholder	Engagement outcome(s) sought	Engagement actions taken	Objections	Key issues raised in consultation to-date	VOGA response to stakeholder feedback	Next steps
			Yes/No/NA			
		<p>VOGA sent a letter on 10 August 2015 regarding the 2015 Wandoo Infill Well Construction campaign.</p> <p>Meetings held with WA DoT 15 December 2015 and 20 January 2016 to discuss changes to the WestPlan Marine Oil Pollution and State water arrangements.</p> <p>VOGA sent a letter on 19 February 2016 regarding the 2016 Wandoo Infill Well Construction campaign.</p> <p>VOGA sent a letter on 19 February 2016 regarding the 2016 Wandoo Infill Well Construction campaign.</p> <p>VOGA met with DoT in October 2017 regarding the Wandoo OPEP, cross jurisdictional arrangements and compliance with the Industry Guidance Note (IGN). VOGA sent relevant information from the OPEP and supporting documentation to DoT in accordance with the IGN (Appendix 4) on 3 November 2017.</p> <p>A desktop exercise ('Exercise Enderby') was held between Vermillion and DoT on 23 February 2018:</p> <ol style="list-style-type: none"> 1. To practice conducting a JSCC meeting between VOGA and DoT in accordance with the protocol in the IGN; 2. To assess the IGN transfer of control checklist using a transfer of Control Agency meeting for a single jurisdiction response; and 3. To explore the incident action planning process that will be used by DoT when VOGA personnel join the DoT IMT. <p>VOGA sent a letter on 20 December 2019 advising that the Well Construction EP was being reviewed to support the statutory requirement for resubmission and acceptance at the end of each period of 5 years, providing relevant activity details and contact details to request further information. The correspondence also advised the following:</p> <p>In accordance with Section 10.6 of the IGN, VOGA considers that no additional consultation is required for the current revision of the document as it has not introduced new or increased environmental risk and/or any material changes in response arrangements that have the potential to impact State waters.</p> <p>The revised OPEP has been reviewed to maintain alignment with the latest IGN (September 2018).</p> <p>VOGA emailed DoT on 3 June 2020 advising that the Wandoo Facility EP was being reviewed due to proposed process changes and to support the statutory a five-yearly resubmission. The correspondence also advised the following:</p> <p>In accordance with Section 10.6 of the IGN, VOGA considers that no additional consultation is required for the current revision of the document as it has not introduced new or increased environmental risk and/or any material changes in response arrangements that have the potential to impact State waters.</p> <p>The revised OPEP has been reviewed to maintain alignment with the latest IGN (September 2018).</p>		<p>Can you please confirm that the Department of Transport 24 hour emergency response number is included in your documentation somewhere?</p> <p>Can you please confirm that there is recognition that we would likely request a POLREP or SITREP following initial verbal notification?</p> <p>Please check your definitions of 'State waters'. There are references to them being 3nm from the coastline which is not correct.</p> <p>9 July 2020 – DoT thanks VOGA for the responses and asked to please ensure that the accepted version of the OSCP was provided to them once finalised</p>	<p>not currently included, however will be for the upcoming resubmission to NOPSEMA.</p> <p>VOGA will also review the 'State waters' definitions to ensure accuracy throughout the document.</p>	



Stakeholder	Engagement outcome(s) sought	Engagement actions taken	Objections	Key issues raised in consultation to-date	VOGA response to stakeholder feedback	Next steps	
			Yes/No/NA				
WA DBCA (previously DPaW)	Establish greater understanding of the Western Australian Government's coordinated oiled wildlife response planning. Notification of well construction activities. Consultation on the proposed modifications to the PFW process.	VOGA sent a letter on 27 January 2014 regarding the Wandoo Facility and Well Construction EPs and activities. DPaW advised, via email on 10 February 2014, that VOGA Operations Activities were unlikely to affect ecologically sensitive receptors in general area. VOGA participated in an AMOSC-led Oiled Wildlife Plans Presentation and Discussion Session on 8 July 2014 - to agree that a common WA Oiled Wildlife Response Plan be adopted. The session was attended by DPaW representatives. VOGA emailed DPaW on 19 November 2014 to provide clarification on our available baseline data and to enquire about accessing known DPaW data. DPaW responded on 9 January 2015. VOGA sent a letter on 10 August 2015 regarding the 2015 Wandoo Infill Well Construction campaign. VOGA sent a letter on 19 February 2016 regarding the 2016 Wandoo Infill Well Construction campaign. VOGA sent a letter and fact sheet on 16 December 2016 regarding the modification to the PFW process. VOGA sent a letter on 1 November 2019 advising that the Well Construction EP was being reviewed to support the statutory requirement for resubmission and acceptance at the end of each period of 5 years, providing relevant activity details and contact details to request further information. VOGA sent a letter and information sheet on 22 May 2020 advising that the Wandoo Facility EP was being reviewed due to proposed process changes, as well as to support a five-yearly resubmission, providing relevant activity details and contact details to request further information.	No	2014 - DPaW sought confidence that VOGA has undertaken investigations and has access to information on baseline ecological condition of sensitive receptors within the ZPI.	2014 - VOGA has undertaken a gap analysis of baseline data within the worst-case ZPI (Astron 2014). A key function of the review was to link the most reliable and relevant baseline data collection with their methodological approaches so that post spill data collection is carried out with the highest likelihood of effectively informing management decisions. Additionally, VOGA has committed to further marine monitoring within the Wandoo Field in the Wandoo Field EP [WPA-7000-YH-0007]. In the absence of required data, the Operational and Scientific Monitoring Plan [WAN-2000-RD-0001.03] has identified methodologies for obtaining relevant baseline data at the time of a spill. During the development of the gap analysis, DPaW was identified as having established marine monitoring programs for sediment quality at Shark Bay, Montebello Islands and Barrow Island, as well as water quality monitoring at various locations. VOGA contacted the DPaW Environmental Management Branch to determine whether this data contains hydrocarbon analysis, as well as how this data could be accessed in the event of a spill.	Continue to keep stakeholders informed during operations.	
				DPaW recommended that VOGA develops and maintains a baseline understanding of shallow water (<2m) and intertidal benthic habitat, sediment and water characteristics, turtle and seabird nesting and roosting sites within a suitable radius of any future activities (as determined in consultation with DPaW). In the absence of current baseline data for any areas affected by future incidental hydrocarbon release, DPaW would assume the baseline state of affected marine and coastal onshore and offshore areas to be pristine and would expect VOGA to return affected areas to their natural state within a period acceptable to regulators and the community.			2014 - VOGA advised DPaW of the process for implementation of the Oiled Wildlife Response Measures, which are detailed in the EP, and acknowledged DPaW's valuable input to the development of these measures.
				2014 - DPaW advised that implementation of its oiled wildlife response must be mandated by regulatory decision makers as part of whole-of-government response.			2014 - Within the Wandoo Field OSCP [WAN-2000-RD-0001], VOGA has identified that DPaW will be invited to participate in the VOGA Incident Command Team during a spill to ensure that the response is reasonable and proportionate and to ensure that resources that may assist DPaW to undertake its function are supplied.
				2014 - DPaW advised that in the event of an oil spill occurring in State waters, the DER Environmental Hazard Branch should be notified as soon as practicable in accordance with the requirements of the Environmental Protection Act 1986. If a site within State jurisdiction is potentially contaminated VOGA must report the area to the DER Contaminated Sites Branch in accordance with the requirements of the Contaminated Sites Act 2003.			2014 - Within the Wandoo Field OSCP [WAN-2000-RD-0001] the VOGA waste management plan identifies companies and resources necessary for the offshore/shoreline temporary storage, marine transport, onshore final disposal, and auditing requirements, to ensure acceptable cradle-to-grave disposal practices are in place for all oily wastes.
				2014 - DPaW advised that the EP must consider the method of disposal of oily waste within State sea or land areas.			



Stakeholder	Engagement outcome(s) sought	Engagement actions taken	Objections	Key issues raised in consultation to-date	VOGA response to stakeholder feedback	Next steps
			Yes/No/NA			
				2020 – No response to consultation to date.	N/A	
WA DPIRD (previously DoF)	Provide DPIRD with information on operations activities. Notification of well construction activities.	<p>VOGA sent a letter on 27 January 2014 regarding the Wandoo Facility and Well Construction EPs and activities.</p> <p>VOGA sent a follow-up email on 25 February 2014.</p> <p>DoF advised it considered itself a 'relevant person' for the proposed activity.</p> <p>VOGA sent a letter on 11 August 2015 regarding the 2015 Wandoo Infill Well Construction campaign.</p> <p>VOGA sent a letter on 19 February 2016 regarding the 2016 Wandoo Infill Well Construction campaign.</p> <p>VOGA sent a letter and fact sheet on 25 October 2016 regarding the modification to the PFW process.</p> <p>VOGA sent a letter and risk assessment on 19 December 2016 responding to the questions raised by DoF on the modification to the PFW process.</p> <p>VOGA sent DPIRD a letter on 1 November 2019 advising that the Well Construction EP was being reviewed to support the statutory requirement for resubmission and acceptance at the end of each period of 5 years, providing relevant activity details and contact details to request further information.</p> <p>VOGA sent a letter and information sheet on 22 May 2020 advising that the Wandoo Facility EP was being reviewed due to proposed process changes, as well as to support a five-yearly resubmission, providing relevant activity details and contact details to request further information.</p>	No	2014 - DoF recommended VOGA consult with WAFIC, Recfishwest and commercial fishers directly with regard to proposed well construction activities.	2014 - VOGA sent letters to WAFIC, Recfishwest and commercial fisheries on 4 July 2014 outlining the proposed activities. No feedback has been received to date. VOGA will engage directly with WAFIC, Recfishwest and commercial fisheries as appropriate.	Ongoing engagement as required, as outlined in Section 9.5.3
				2014 - DoF requested that VOGA collect baseline marine data to compare against any post-spill monitoring to determine the nature and extent of any impacts, and specific strategies are developed in EP and/or OSCP to mitigate the risks of spills on fish spawning areas.	2014 - VOGA has undertaken a gap analysis of baseline data within the worst-case ZPI (see DPaW response). Strategies to mitigate the impact of a hydrocarbon spill on sensitive environmental receptors, including impacts on fish and fisheries, have been detailed in the Wandoo Field OSCP [WAN-2000-RD-0001].	
				2014 - DoF requested that the risk of translocating pests and diseases via immersible equipment be minimised.	2014 - VOGA has identified and risk assessed the potential for introducing invasive marine species and developed appropriate controls. These controls include vessels obtaining quarantine clearance prior before entering Australian waters and current International Anti-fouling System Certificate for all support vessels.	
				2016 - DoF requested that affected fishers are consulted prior to the commencement of the proposed PFW modifications. DoF recommended that VOGA maintains ongoing consultation with WAFIC, the Pearl Producers Association of WA, Recfishwest, DPaW and directly with fishers (acknowledging that VOGA had already undertaken consultation with WAFIC and fishers). DoF also requested that the paper by Bakke et al. (2013) be considered in the PFW impact assessment and notified if mortality of individual "fish" is likely.	2016 - VOGA sent letters and the fact sheet regarding the proposed modifications to the PFW process to Recfishwest, DPaW and the Pearl Producers Association at the request of DoF. Pearl Producers Association were acknowledged as interested due to their Zone 1 fishing zone surrounding the Wandoo Permit Area (currently inactive). VOGA provided a summary copy of the PFW risk assessment to DoF and provided context of our risk assessment to the results of the Bakke et al. (2013) paper. It was noted that drill cuttings are not included within the scope of the Wandoo Facility Environment Plan and are therefore outside the scope of the submission. Vermilion will review this information as part of our Well Construction Environment Plan annual review. VOGA confirmed that no mortality to individual 'fish' was assessed as likely.	
				2020 – No response to consultation to date.	N/A	



Stakeholder	Engagement outcome(s) sought	Engagement actions taken	Objections	Key issues raised in consultation to-date	VOGA response to stakeholder feedback	Next steps
			Yes/No/NA			
AFMA	Notification of well construction activities. Consultation on the proposed modifications to the PFW process.	<p>VOGA sent a letter on 27 January 2014 regarding the Wandoo Facility and Well Construction EPs and activities.</p> <p>AFMA confirmed via email on 29 January 2014 that it has developed new guidelines and a Fishing Consultation Directory to assist the petroleum industry.</p> <p>AFMA had no further comments on these specific activities as the area does not appear to overlap with any Commonwealth fisheries.</p> <p>AFMA would appreciate further consultation when there is any change to VOGA activities.</p> <p>VOGA sent a letter on 11 August 2015 regarding the 2015 Wandoo Infill Well Construction campaign.</p> <p>VOGA sent a letter on 19 February 2016 regarding the 2016 Wandoo Infill Well Construction campaign.</p> <p>AFMA acknowledged the 19 February 2016 letter with no comments other than to ensure that VOGA continue to consult with affected fishers in the area, and requested that all future correspondence be sent to petroleum@afma.gov.au.</p> <p>VOGA sent a letter and fact sheet on 25 October 2016 regarding the modification to the PFW process.</p> <p>VOGA sent a letter on 1 November 2019 advising that the Well Construction EP was being reviewed to support the statutory requirement for resubmission and acceptance at the end of each period of 5 years, providing relevant activity details and contact details to request further information.</p> <p>VOGA sent a letter and information sheet on 22 May 2020 advising that the Wandoo Facility EP was being reviewed due to proposed process changes, as well as to support a five-yearly resubmission, providing relevant activity details and contact details to request further information.</p>	No	<p>2016 - AFMA recommended engaging directly with fishers ahead of drilling.</p> <p>2020 – No response to consultation to date.</p>	<p>2016 - Letters were issued to fishing licence holders in the vicinity of the Wandoo facility and the WA Pearl Producers Association, which distributed the letter to its members.</p> <p>VOGA will engage directly with fishers as appropriate ahead of drilling.</p> <p>N/A</p>	Continue to keep stakeholders informed during operations.
Commercial fisheries	Notification of well construction activities.	<p>VOGA sent letters on 4 July 2014 regarding the Wandoo Facility and Well Construction EPs and activities.</p> <p>VOGA sent letters on 12 August 2015 regarding the 2015 Wandoo Infill Well Construction campaign.</p> <p>VOGA sent letters on 19 February 2016 regarding the 2016 Wandoo Infill Well Construction campaign.</p> <p>VOGA sent letters and the fact sheet on 25 July 2016 regarding the modification to the PFW process.</p> <p>VOGA sent letters on 5 September 2018 regarding the upcoming 2018/19 Wandoo Well Construction campaign.</p> <p>VOGA sent letters to individual fishers of active fisheries overlapping or in close vicinity of the planned petroleum activity (in accordance with Section 9.3.1.2) on 1 November 2019 advising that the Well Construction EP was being reviewed to support the statutory requirement for resubmission and acceptance at the end of each period of 5 years, providing relevant activity details and contact details to request further information.</p>	No	No issues raised in consultation to date.	N/A	Ongoing engagement as required, as outlined in Section 9.5.3



Stakeholder	Engagement outcome(s) sought	Engagement actions taken	Objections	Key issues raised in consultation to-date	VOGA response to stakeholder feedback	Next steps
			Yes/No/NA			
		VOGA sent letters to individual fishers of active fisheries overlapping or in close vicinity of the planned petroleum activity on 3 June 2020 advising that the Wandoo Facility EP was being reviewed due to proposed process changes, and to support a five-yearly resubmission, providing relevant activity details and contact details to request further information.				
WAFIC	Provide information on proposed operations activities. Notification of well construction activities. Consultation on the proposed modifications to the PFW process.	VOGA sent a letter on 27 January 2014 regarding the Wandoo Facility and Well Construction EPs and activities. VOGA sent a follow-up email on 25 February 2014. VOGA sent a letter on 11 August 2015 regarding the 2015 Wandoo Infill Well Construction campaign. VOGA sent a letter on 19 February 2016 regarding the 2016 Wandoo Infill Well Construction campaign. Meeting with WAFIC on 21 July 2016 regarding the modification to the PFW process. VOGA sent an email on and fact sheet on 6 September 2018 informing WAFIC of the upcoming 2018/19 Wandoo Well Construction campaign. VOGA sent a letter on 1 November 2019 advising that the Well Construction EP was being reviewed to support the statutory requirement for resubmission and acceptance at the end of each period of 5 years, providing relevant activity details and contact details to request further information. VOGA followed up with an email on 15 November 2019 advising that a number of individual licence holders were being consulted with directly regarding the well construction activity, and provided an example of the information they would receive. WAFIC replied on 15 November 2019 with a number of concerns and queries related to the stakeholder consultation approach, information provided and activity interaction with fishers and fish. WAFIC also attached the WAFIC's fee-for-service information and advised that they believe it can add significant value in information review and dissemination of information services. WAFIC advised that they can do the full commercial fishing consultation with a complete detailed report subject to other ongoing work commitments. VOGA responded to the concerns and queries with a letter on 3 January 2020. VOGA followed up with an email to WAFIC clarifying the approach to consultation with commercial fisheries on 8 January 2020. WAFIC responded on 8 January 2020 regarding the fisheries considered relevant and the fisheries within the EMBA, plus queries. VOGA responded on 9 January 2020 and clarified the approach, answered the queries and noted the comments. VOGA sent a letter and information sheet on 25 May 2020 advising that the Wandoo Facility EP was being reviewed due to proposed process changes, as well as to support a five-yearly resubmission,	No	2019 – WAFIC advised that: They insist on information bespoke for the commercial fishing sector; The fisheries identified to be “relevant potentially affected parties” to the activities described in the EP are wrong; Consultation fatigue is very real so therefore difficult to get a reply if not succinct and if not commercial fishing focussed; Identify upfront any potential impacts to commercial fishing activities and the commercial fishing resource (i.e. key indicator species); What happens in worse possible scenario situation, what science are you relying on for an accurate before and after assessment of commercial fishing key indicator species?; Identify active fisheries (state and commonwealth managed) with legal fishery boundaries overlapping the Wandoo site; If a fishery is not active over the site no consultation is required but you must account for the resource in the EP; What is Vermillion’s policy in relation to “No fishing from support/commercial vessels”?; What processes does Vermillion have in place to quantitatively assess any damage to fish stocks in the event of a spill event? What science are you using to demonstrate that Vermillion has a full understanding of fish spawning practices and will avoid any activities which may potentially impact fish spawning periods; What lessons has Vermillion learned from other global spill events, especially in relation to emergency response time and (early) control of the oil loss in Australia’s isolated north west oceans?; Is Vermillion’s staff, and contractors and sub-contractors all aware of the difference between exclusion zones and cautionary zones?;	2019 – VOGA responded that: Given the range of stakeholders with whom Vermilion must consult, we endeavour where possible to tailor information to be relevant to stakeholders. We have provided relevant information on which stakeholders can form a view as to the appropriateness of the controls that Vermilion implements as part of our activities in the Wandoo field; Vermilion has reviewed and considered the legal fishery boundaries overlapping the Wandoo site through various sources. Attached the VOGA stakeholder identification and classification information relevant to the activity. On review of this information if you still believe that the identified fisheries are incorrect, Vermilion would like to work collaboratively with WAFIC to ensure we communicate with the correct stakeholders going forward; Within Project exclusion zone area - VOGA doesn’t permit fishing (commercial or recreational) from vessels. This policy is enforced and communicated to all our contractors and subcontractors and third parties. Vessels outside the project exclusion zone are not under the control of VOGA and therefore are not within the scope of our EP; Vermilion has a Wandoo Field Operational and Scientific Monitoring Plan (OSMP). This OSMP is informed by the sensitive receptors that could be impacted during a hydrocarbon spill, as identified in the EP. This OSMP has a suite of fisheries-specific Operational and Scientific Monitoring Programs to inform effectiveness of spill response and to quantify and assess impacts (and recovery) during and post spill; Vermilion is not conducting further stock assessment research for commercial fisheries species given stock assessment information is routinely produced by Australian Fisheries Management Authority (AFMA) and WA Department of Primary Industries and Regional Development (DPIRD) fishing authorities;	Ongoing engagement as required, as outlined in Section 9.5.3



Stakeholder	Engagement outcome(s) sought	Engagement actions taken	Objections	Key issues raised in consultation to-date	VOGA response to stakeholder feedback	Next steps
			Yes/No/NA			
		<p>providing relevant activity details and contact details to request further information. VOGA also advised that individual licence holders for certain relevant fisheries were being consulted with directly.</p>		<p>What is Vermillion’s communication policy with all staff and vessel crew, contractors and sub-contractors regarding interacting and protecting the rights of active commercial fishers on the water?</p> <p>25 May 2020 – WAFIC advised the following issues with the consultation approach: Your fact sheet and letter are in oombie-goombie oil and gas speak. WAFIC loathes the one size fits nobody approach. By stating the words “commercial fishing” a couple of times does not make this bespoke to our industry. Simple dot point summary information (at least in the covering email / letter). You talk about “stakeholders” - you need to communicate with commercial fishers as potentially affected and relevant parties. You are noted that you have not received feedback in the past, don’t count this as no issues from potentially affected and relevant parties, quite possibly due to the poor information sent – not worth wasting our collective time digging through both documents, reading, assessing and evaluating. We expect / demand bespoke information relevant to the commercial fishing sector. What is different from this EP / 5-year update to the previous EP? How will these changes potentially impact commercial fishers? If there is a major spill, it WILL impact fish – surface oil etc etc etc. Water depth? Requested previously, crucial information for fishers – not good enough to try and read the bathy lines off the map. All other queries – repeat the points I raised in WAFIC’s email of 20/12/2019 (attached above). “WAFIC has significant issues with the information proposed to being disseminated by Vermillion to the commercial fishing sector. It is also not WAFIC’s role to be a coach/ auditor /free secretarial service to cross check, assess and review your information”.</p>	<p>The EP describes known spawning/aggregation periods for commercial fish species; VOGA has a comprehensive source control, emergency response and oil spill management procedures and processes in place which are documented within the Wandoo Field OSCP; VOGA staff and contractors are aware of the difference between exclusion and cautionary zones; Potential impacts associated with Project vessels interactions with other marine users (inclusive of recreation and commercial fishers) utilising Wandoo field regions have been conducted as part of project risk assessment and considered within the EP. Majority of project vessel movements is to and from Dampier Port or waiting on standby within the Wandoo Field; this is consistent with our day-to-day operational activities at Wandoo. Given our proximity to the port and the commercial vessel traffic in our area we are unlikely to create any additional impact to fishing vessels than what currently exists in the area. As per previous campaigns, Vermilion has procedures in place to ensure Project vessels operate according to AMSA requirements and in line with consultation feedback from maritime stakeholders. WAFIC emailed on 8 January 2020 and identified some errors in fishery identification and asked questions on the stakeholder approach to fisheries. VOGA followed up with emails to WAFIC clarifying the approach to consultation with commercial fisheries (8 and 9 January 2020).</p> <p>28 May 2020 – phone call between Glen Nicholson (VOGA) and Mannie Shea (WAFIC) regarding more specific and ‘punchy’ consultation information for commercial fishers, a template that WAFIC could provide VOGA, and the WAFIC fee for service consultation service.</p> <p>29 May 2020 – VOGA responded by thanking WAFIC for the template and verbal advice, and providing an amended (commercial fishers specific) letter and information sheet.</p>	



Stakeholder	Engagement outcome(s) sought	Engagement actions taken	Objections	Key issues raised in consultation to-date	VOGA response to stakeholder feedback	Next steps
			Yes/No/NA			
				<p>Please ensure this correspondence is included in full in your EP submission so NOPSEMA is well aware of WAFIC's full feedback.</p> <p>28 May 2020 – WAFIC provided VOGA with a suggested commercial fishers specific email template, and advised that the accompanying fact sheet must be commercial fishing specific. More information but in blocks, not long-winded prose.</p>		
Pearl Producers Association	Provide information on operational activities. Consultation on the proposed modifications to the PFW process.	VOGA sent a letter on 18 August 2014 regarding the VOGA Wandoo Field Activities. VOGA sent a response email on 18, 19, 21 & 27 August 2014. VOGA sent a letter and fact sheet on 16 December 2016 regarding the modification to the PFW process. VOGA sent an email and fact sheet on 6 September 2018 informing PPA of the upcoming 2018/19 Wandoo Well Construction campaign. VOGA sent a letter on 1 November 2019 advising that the Well Construction EP was being reviewed to support the statutory requirement for resubmission and acceptance at the end of each period of 5 years, providing relevant activity details and contact details to request further information. VOGA sent a letter and information sheet on 22 May 2020 advising that the Wandoo Facility EP was being reviewed due to proposed process changes, as well as to support a five-yearly resubmission, providing relevant activity details and contact details to request further information.	No	Pearl Producers Association requested on 19 August 2016 clarification on whether the VOGA operations are new or existing.	VOGA confirmed via email on 19 August 2014 that the operations and well construction activated are existing.	Continue to keep stakeholders informed during operations.
				Pearl Producers Association requested on 21 August 2014 an improved map to include the water depth contours of the Permit area.	VOGA provided updated maps to Pearl Producers Association, including depth contours via email on 27 August 2014.	
				Pearl Producers Association requested clarification on 21 August 2014 whether seismic survey activity formed part of the proposed operational activities.	VOGA confirmed with Pearl Producers Association via email on 21 August 2014 that no seismic survey activity is contained within the proposed operational activities.	
				2020 – No response to date	2020 – N/A	



Stakeholder	Engagement outcome(s) sought	Engagement actions taken	Objections	Key issues raised in consultation to-date	VOGA response to stakeholder feedback	Next steps
			Yes/No/NA			
Recfishwest	<p>Provide information on operational activities.</p> <p>Notification of well construction activities.</p> <p>Consultation on the proposed modifications to the PFW process.</p>	<p>VOGA sent letters on 4 July 2014 regarding the Wandoo Facility and Well Construction EPs and activities.</p> <p>VOGA sent a letter on 10 August 2015 regarding the 2015 Wandoo Infill Well Construction campaign.</p> <p>VOGA sent a letter on 19 February 2016 regarding the 2016 Wandoo Infill Well Construction campaign.</p> <p>VOGA sent a letter and fact sheet on 19 December 2016 regarding the modification to the PFW process.</p> <p>VOGA sent an email and fact sheet on 6 September 2018 informing PPA of the upcoming 2018/19 Wandoo Well Construction campaign.</p> <p>VOGA sent a letter on 1 November 2019 advising that the Well Construction EP was being reviewed to support the statutory requirement for resubmission and acceptance at the end of each period of 5 years, providing relevant activity details and contact details to request further information.</p> <p>VOGA sent a letter and information sheet on 22 May 2020 advising that the Wandoo Facility EP was being reviewed due to proposed process changes, as well as to support a five-yearly resubmission, providing relevant activity details and contact details to request further information.</p>	No	No issues raised in consultation to date.	N/A	Continue to keep stakeholders informed during operations.
Jadestone	<p>Notification of well construction activities.</p>	<p>VOGA sent a letter on 1 November 2019 advising that the Well Construction EP was being reviewed to support the statutory requirement for resubmission and acceptance at the end of each period of 5 years, providing relevant activity details and contact details to request further information.</p> <p>VOGA sent a letter and information sheet on 22 May 2020 advising that the Wandoo Facility EP was being reviewed due to proposed process changes, as well as to support a five-yearly resubmission, providing relevant activity details and contact details to request further information.</p>	No	No issues raised in consultation to date.	N/A	Continue to keep stakeholders informed during operations.

9.5.3 Ongoing stakeholder consultation

Should any significant change to the potential or actual environmental impacts detailed in the EP for any Wandoo Facility operations, maintenance, inspection or project activities be identified, VOGA will inform all relevant stakeholders in writing of the change and seek feedback via a consultative process.

Stakeholders will be able to access information on VOGA's activities via NOPSEMA's website where the full EP will be published.

VOGA has provided all stakeholders with contact details, and the company can be contacted directly regarding any aspect of our activity. Each enquiry will be carefully considered with responses provided in a timely manner.

Table 9-3: Ongoing consultation

Consultation Trigger	Stakeholders	Frequency	Media (i.e. email, post, meetings)
Vermilion Environmental Report - summarising Vermilion's environmental performance and activities.	Available to all stakeholders.	Annual.	Report available on the Vermilion website.
Significant change to the potential or actual environmental impacts detailed in the Wandoo Facility EP for any given operation or activity.	All stakeholders identified as relevant or interested.	Prior to revised EP submission.	To be determined at the time of consultation.
Update of OSCP	Oil Spill Response stakeholders	As required.	To be determined at the time of consultation.
Triggered consultation project or activity updates.	Consulted stakeholders, as appropriate.	As required.	To be determined at the time of consultation.



References

- Adams, G.G., Klerks, P.L., Belanger, S.E., and Dantin, D. (1999). The Effect of the Oil Dispersant Omni-Clean on the Toxicity of Fuel Oil No. 2 in Two Bioassays with the Sheepshead Minnow *Cypridon variegates*. *Chemosphere* 39: pp. 2141–2157.
- Albers, P.H. (1979). Effect of Corexit 9527 on the hatchability of Mallard eggs. *Bulletin of Contamination and Environmental Toxicology* 23:661-668; Op cit. 31.
- Allan, G.L., Maguire, G.B., and Hopkins, S.J. (1990). Acute and chronic toxicity of ammonia to juvenile *Metapenaeus macleayi* and *Penaeus monodon* and the influence of low dissolved oxygen levels. *Aquaculture*, 91, 265-280.
- Ampolex Limited. (1995). Wandoo Full Field Development Public Environment Report, November 1995.
- AMSA (2002). The Effects of Maritime Oil Spills on Wildlife including Non-Avian Marine Life. Australian Maritime Safety Authority, Canberra.
- AMSA (2015). Technical Guideline for the Preparation of Marine Pollution Contingency Plans for Marine and Coastal Facilities. Australian Maritime Safety Authority, Canberra.
- AMSA (2012). The National Plan to Combat Pollution of the Sea by Oil and other Noxious and Hazardous Substances, Protocol for the Register of Oil Spill Control Agents. Australian Maritime Safety Authority, Canberra.
- Anderson, P.K. (1981). The behaviour of the dugong (*Dugong dugon*) in relation to conservation and management. *Bulletin of Marine Science* 31: 640-647.
- Anderson, P.K. (1997). Shark Bay dugongs in summer. I: Lek mating. *Behaviour* 134(5-6): 433-462.
- ANZECC & ARMCANZ (2000). National Water Quality Management Strategy: An introduction to the Australian and New Zealand guidelines for fresh and marine water quality, Australian Government Department of Sustainability, Environment, Water, Population and Communities, Viewed online <http://www.environment.gov.au/water/policy-programs/nwqms/>
- ANZECC / ARMCANZ 2018. Australian & New Zealand Guidelines for Fresh & Marine Water Quality Management Framework. <https://www.waterquality.gov.au/anz-guidelines>
- APASA (2012). Oil Spill Modelling for the Wandoo Production Platform, Western Australia. Prepared for Vermillion Energy. August 2012.
- APASA (2013a). Wandoo Operations, North West Shelf. Produced formation water discharge modelling. APASA Project Q0197. Revision 1 - 19/07/2013.
- APASA (2013b). Wandoo Production Platform Loss of Well Control Oil Spill Modelling Study. Prepared for Vermillion Energy. September 2013.
- APASA (2013c). Wandoo Production Platform Oil Tanker Cell Spill Modelling Study. Prepared for Vermillion Energy. September 2013.
- ASTM (1987). Ecological Considerations for the Use of Chemical Dispersants in Oil Spill Response – Coral Reefs. In: Annual Book of Standards, v11.04, pp. 909-923, 832-938, 941-961. Standard F971-86. American Society of Testing and Materials. Philadelphia.
- Atkins, Collision Frequency Energy Assessment, 5153649-SA-REP-001
- Australian Fisheries Management Authority (2008a). *Western Deepwater Trawl Fishery Data Summary*. Australian Fisheries Management Authority, Canberra.
- Australian Fisheries Management Authority (2008b). *North West Slope Trawl Fishery Data Summary*. Australian Fisheries Management Authority, Canberra.
- Australian Fisheries Management Authority (2009). *Annual Status Report Western Tuna and Billfish Fishery*. Australian Fisheries Management Authority, Canberra.
- Australian Fisheries Management Authority (2010). *Annual Status Report Skipjack Tuna Fishery*. Australian Fisheries Management Authority, Canberra.
- Baca, B.J., and Getter, C.D. (1984). The Toxicity of Oil and Chemical Dispersants: Research Experience and Recommendations. ASTM Publication.
- Baird, A.H., Blakeway, D.R., Hurley, T.J., and Stoddart, J.A. (2011). Seasonality of coral reproduction in the Dampier Archipelago, northern Western Australia. *Marine Biology* 158: 275-285.

- Baker, C., Potter, A., Tran, M., and Heap, A.D. (2008). Geomorphology and Sedimentology of the Northwest Marine Region of Australia. *Geoscience Australia, Record 2008/07*. Geoscience Australia, Canberra.
- Baker, C.S., and Herman, L.M. (1989). Behavioural responses of summering humpback whales to vessel traffic: experimental and opportunistic observations. Final Report to the National Park Service. US Department of the Interior, Anchorage, AK.
- Baker-Hughes (2007). Safety Data Sheet XC24380 [Material Safety Data Sheet]. Retrieved from: <http://www.scribd.com/doc/137299617/XC24380-MSDS>.
- Baker-Hughes (2010). Material Safety Data Sheet Tretolite RBW24362 (reverse emulsion breaker) (January 2010).
- Baker-Hughes (2010b). Safety Data Sheets OSW 24017 (oxygen scavenger) (December 2010).
- Ballou, T.G., Dodge, R.E., Hess, S.C., Knap, A.h., and Sleeter, T.D. (1987). Effects of a Dispersed and Undispersed Crude Oil on Mangroves, Seagrasses and Corals, American Petroleum Institute, Washington DC.
- Bancroft, K. P. (2003). A standardised classification scheme for the mapping of shallow-water marine habitats in Western Australia. Marine Conservation Branch, Department of Conservation and Land Management, Report MCB-05/2003. Fremantle, WA, Australia.
- Bannister, A., Kemper, C.M., and Warnecke, R.M. (1996). *The Action Plan for Australian Cetaceans*. Australian Nature Conservation Agency, Canberra.
- Becking, J.H. (1976). Feeding range of Abbott's Booby at the coast of Java. *Ibis*. 118:589-590.
- Bennelongia (2009). Ecological Character Description for Roebuck Bay. Report to the Department of Environment and Conservation. Bennelongia Pty Ltd, Jolimont.
- Bennett, M., and Bansemer, C. (2004). Investigations of Grey Nurse Shark in Queensland to fulfil actions under the Recovery Plan for Grey Nurse Shark (*Carcharias taurus*) in Australia regarding impact of divers, and establishment of a photographic database to improve knowledge of migratory movements, localised site movements and estimation of bycatch. Prepared for Department of Environment and Heritage by School of Biomedical Sciences, The University of Queensland, Brisbane.
- BHP Billiton (2005). Pyrenees Development Draft Environmental Impact Statement (EIS). BHP Billiton. Perth.
- Birkhead, T.R., Lloyd, C. and Corkhill, P. (1973). Oiled seabirds successfully clean their plumage. *British Birds*, 66: 535–537.
- Bjorndal, K.A. (1985). Nutritional Ecology of Sea Turtles. *Copeia* 3: 736–751.
- Black, K.P., Brand, G.W., Grynberg, H., Gwyther, D., Hammond, L.S., Mourtikas, S., Richardson, B.J., and Wardrop, J.A. (1994). Production Facilities. In: *Environmental Implications of Offshore Oil and Gas Development in Australia - The Findings of an Independent Scientific Review*.
- Blakeway, D. and Radford, B.T.M. (2005). Scleractinian corals of the Dampier Port and inner Mermaid Sound: species list, community composition and distributional data. In Stoddart, J.A. and Stoddart, S.E. (eds). *Corals of the Dampier Harbour: Their Survival and Reproduction during the Dredging Programs of 2004*. MScience Pty Ltd, Perth, Western Australia, pp1-11.
- Blumer, M. (1971). Scientific aspects of the oil spill problem. *Environmental Affairs* 1, 54-73.
- Bowman Bishaw Gorham (BBG) (1996). Environmental Baseline Survey Wandoo B. Report prepared for Ampolex Ltd (Ampolex Report Number 17486).
- Boyd, J.N., Scholz, D., and Hayward-Walker, A. (2001). Effects of Oil and Chemically Dispersed Oil in the Environment. International Oil Spill Conference, pp. 1213-1216.
- Branch, T.A., Stafford, K.M., Palacios, D.M., Allison, C., Bannister, J.L., Burton, C.L.K., Cabrera, E., Carlson, C.A., Galletti Vernazzani, B., Gill, P.C., Hucke-Gaete, R., Jenner, K.C.S., Jenner, M.N.M., Matsuoka, K., Mikhalev, Y.A., Miyashita, T., Morrice, M.G., Nishiwaki, S., Sturrock, V.J., Tormosov, D., Anderson, R.C., Baker, A.N., Best, P.B., Borsa, P., Brownell Jr, R.L., Childerhouse, S., Findlay K.P., Gerrodette, T., Ilangakoon, A.D., Joergensen, M., Kahn, B., Ljungblad, D.K., Maughan, B., McCauley, R.D., McKay, S., Norris, T.F., and Rankin, S. (2007). Past and present distribution, densities and movements of blue whales *Balaenoptera musculus* in the Southern Hemisphere and northern Indian Ocean. *Mammal Review* 37:116–175.
- Brewer, D., Lyne, V., Skewes, T., and Rothlisberg, P. (2007). *Trophic systems of the North West Marine Region*. Report to the Department of the Environment and Water Resources. CSIRO Marine and Atmospheric Research, Australia.
- Brown, R.G.B. (1992). Oil and Seabirds of Atlantic Canada. In: Ryan, P.M. (ed), 1993. *Managing the Environmental Impact of Offshore oil production*. Canadian Society of Environmental Biologists, Canada.
- Bureau of Meteorology (BOM) (2012). *Climatology of Tropical Cyclones in Western Australia*. Accessed 13 April 2012. <<http://www.bom.gov.au/cyclone/climatology/wa.shtml>>

- Burns, K.A. and Codi, S. (1999). Non-volatile Hydrocarbon Chemistry Studies Around a Production Platform on Australia's Northwest Shelf. *Estuarine, Coastal and Shelf Science* (1999) 49, 853–876.
- Burns, K.A., Codi, S., Pratt, C., and Duke, N.C. (1999). Weathering of hydrocarbons in mangrove sediments: testing the effects of using dispersants to treat oil spills, *Organic Geochemistry*, Vol. 30, pp. 1273-1286 Australia.
- Butcher, R. and Hale, J. (2010). Ecological Character Description for The Dales Ramsar Site. Report to the Department of Sustainability, Environment, Water, Population and Communities, Canberra.
- CALM (2005). Indicative Management Plan for the Proposed Dampier Archipelago Marine Park and Cape Preston Marine Management Area. Department of Conservation and Land Management, Perth, Western Australia.
- CALM and MPRA (2005). Management Plan for the Ningaloo Marine Park and Muiron Islands Marine Management Area 2005–2015. Management Plan No. 52. Department of Conservation and Land Management and Marine Parks and Reserves Authority.
- Campana, S.E., Marks, L., and Joyce, W. (2005). The biology and fishery of shortfin mako sharks (*Isurus oxyrinchus*) in Atlantic Canadian waters. *Fisheries Research* 73: 341-352.
- Carr, A., and Stancyk, S. (1975). Observations on the ecology and survival outlook of the hawksbill turtle. *Biological Conservation* 8: 161-172.
- Carr, B., and Livesey, N. (1996). *Pilbara Mangrove Study*. Prepared for the Heritage Council of Western Australia. Murdoch University, Perth.
- Cassata, L., and Collins, L.B. (2008). Coral reef communities, habitats and substrates in and near sanctuary zones of Ningaloo Marine Park. *Journal of Coastal Research*, Vol. 241: 39–151.
- Cavanagh, R.D., Kyne, P.M., Fowler, S.L., Musick, J.A., and Bennett, M.B. (eds). (2003). The Conservation Status of Australasian Chondrichthyans: Report of the IUCN Shark Specialist Group Australia and Oceania Redlist Workshop. Brisbane, Australia: The University of Queensland, School of Biomedical Sciences. 170 p.
- Chatto, R. (1995). Sea turtles killed by flotsam in northern Australia. *Marine Turtle Newsletter* 69: 17-18.
- Chatto, R. (1998). A preliminary overview of the locations of marine turtle nesting in the Northern Territory. In R. Kennett, A. Webb, G. Duff, M. Guinea and G. Hill (eds). *Marine turtle conservation and management in northern Australia*. Northern Territory University, Darwin.
- Chen, J-C., and Lin, C-Y. (1991). Lethal effects of ammonia and nitrite on *Penaeus penicillatus* juveniles at two salinity levels. *Comparative Biochemistry and Physiology*, 100C, 477-482.
- Chevron Australia (2005). Environmental Impact Statement/Environmental Review and Management Programme for the proposed Gorgon Development. Chevron Australia Pty Ltd, Perth, Western Australia.
- Chevron Australia (2008). Gorgon Gas Development Revised and Expanded Proposal Public Environmental Review Operated by Chevron Australia in joint venture with Gorgon Project. EPBC Referral 2008/4178 Assessment No. 1727. Chevron Australia Pty Ltd, Perth, Western Australia, September 2008.
- Chevron Australia (2009). Gorgon Gas Development and Jansz Feed Gas Pipeline Long Term Marine Turtle Management Plan. Chevron Australia Pty Ltd, Perth.
- Chevron Australia (2010). Gorgon Gas Development and Jansz Feed Gas Pipeline Coastal and Marine Baseline State and Environmental Impact Report. Chevron Australia Pty Ltd, Perth.
- Cintron, G., Lugo, A.E., Martinez, R., Cintron, B.B., and Encarnacion, L. (1981). Impact of oil in the tropical marine environment. Technical Publication, Division of Marine Research, Department of Natural Resources, Puerto Rico.
- Clark, J.R., Bragin, G.E., Febbo, R.J., and Letinski, D.J. (2001). Toxicity of physically and chemically dispersed oils under continuous and environmentally realistic exposure conditions: Applicability to dispersant use decisions in spill response planning. *Proceedings of the 2001 International Oil Spill Conference*. Pp. 1249-1255, Tampa, Florida. American Petroleum Institute, Washington, D.C. Commonwealth of Australia. 2002. Ningaloo Marine Park (Commonwealth Waters) Management Plan. Environment Australia, Canberra.
- Clark, R.B. (1984). Impact of pollution on seabirds. *Environmental Pollution* 33: 1–22.
- Codi King, S., Conwell, C., Haasch, M., Mondon, J., Müeller, J., Zhu, S., and Howitt, L. (2011). Field Evaluation of a Suite of Biomarkers in an Australian Tropical Reef Species, Stripey Seaperch (*Lutjanus carponotatus*): Assessment of Produced Formation Water from the Harriet A Platform, 261-294.pgs. In: (Neff and Lee, eds) Produced Water Discharge from Offshore Oil and Gas Facilities: Environmental Risks and Advances in Mitigation Technologies. Springer, NY.
- Coelho, G., Clark, J., and Aurand, D. (2013). Toxicity testing of dispersed oil requires adherence to standardized protocols to assess potential real world effects. *Environmental Pollution* (2013), <http://dx.doi.org/10.1016/j.envpol.2013.02.004>

- Collette, B.B., and Nauen, C.E. (1983). FAO species catalogue. Vol. 2. Scombrids of the world. An annotated and illustrated catalogue of tunas, mackerels, bonitos and related species known to date. FAO Fisheries Synopsis (125) Vol. 2: 137 p.
- Compagno, L.J.V. (1984). FAO Species Catalogue. Vol. 4 Sharks of the World. United Nations Development Programme, Food and Agriculture Organization of the United Nations. Rome.
- Condie, S., Andrewartha, J., Mansbridge, J., and Waring, J. (2006). Modelling circulation and connectivity on Australia's North West Shelf. *North West Shelf Joint Environmental Study Technical Report No. 6*. CSIRO Marine and Atmospheric Research, Australia.
- Connell, D.W., and Miller, G.J. (1981). Petroleum hydrocarbons in aquatic ecosystems – behaviour and effects of sublethal concentrations. CRC Report: Critical Reviews in Environmental Controls.
- Costello, M.J., and Read, P. (1994). Toxicity of sewage sludge to marine organisms: a review. *Marine Environmental Research* 37: 23–46.
- Coutou, E.I. Castritis-Catharios and Moraitou-Apostolopoulo, M. (2001). Surfactant-based oil dispersant toxicity to developing nauplii of *Artemia*: effects on ATPase enzymatic system. *Chemosphere* 42: 959-964.
- D'Adamo, N., Fandry, C., Buchan, S., and Domingues, C. (2009). Northern sources of the Leeuwin Current and the "Holloway Current" of the North West Shelf. *Journal of the Royal Society of Western Australia* 92: 53-66.
- Davis, T.L.O., Jenkins, G.P., and Young, J.W. (1990). Diel patterns of vertical distribution in larvae of southern Bluefin *Thunnus maccoyii*, and other tuna in the East Indian Ocean. *Marine Ecology Progress Series* Vol. 59: 63-74.
- de Lestang, S., Caputi, N., How, J., Melville-Smith, R., Thomson, A., and Stephenson, P. (2012). Stock Assessment for the West Coast Rock Lobster Fishery. Fisheries Research Report No. 217. Department of Fisheries, Western Australia. 200pp
- Den Hartog, C. (1984). *Seagrasses of the World*. North Holland Publishing Company, Amsterdam.
- Department of Agriculture, Fisheries and Forestry (2009a). Australian marine pest monitoring guidelines (Version 2). Australian Government Department of Agriculture Fisheries & Forestry. Commonwealth of Australia, Canberra.
- Department of Agriculture, Fisheries and Forestry (2011a). Australian Ballast Water Management Requirements. National Seaports Program. Department of Agriculture, Fisheries and Forestry. Canberra. Version 5, November 2011.
- Department of Agriculture, Fisheries and Forestry (2011b). National Biofouling Management Guidance for the Petroleum Production and Exploration Industry Australian Government Department of Agriculture Fisheries and Forestry. Commonwealth of Australia, Canberra.
- Department of Agriculture, Water and the Environment (2020a). Ashmore Reef National Nature Reserve, Timor Sea, EXT, Australia. Accessed on 25 March 2020 at http://www.environment.gov.au/cgi-bin/ahdb/search.pl?mode=place_detail;place_id=105218
- Department of Agriculture, Water and the Environment (2020b). Christmas Island Natural Areas, Settlement, EXT, Australia. Accessed on 25 March 2020 at http://www.environment.gov.au/cgi-bin/ahdb/search.pl?mode=place_detail;place_id=105187
- Department of Agriculture, Water and the Environment (2020c). Learmonth Air Weapons Range Facility, Learmonth, WA, Australia. Accessed 25 March 2020 at http://www.environment.gov.au/cgi-bin/ahdb/search.pl?mode=place_detail;place_id=105551
- Department of Agriculture, Water and the Environment (2020d). Mermaid reef- Rowley Shoals, Broome, WA, Australia. Accessed on 25 March 2020 at http://www.environment.gov.au/cgi-bin/ahdb/search.pl?mode=place_detail;place_id=105255.
- Department of Agriculture, Water and the Environment (2020e). Ningaloo Marine Area- Commonwealth Waters, Ningaloo, WA, Australia. Accessed on 25 March 2020 at http://www.environment.gov.au/cgi-bin/ahdb/search.pl?mode=place_detail;place_id=105548
- Department of Agriculture, Water and the Environment (2020f). North Keeling Island, EXT, Australia. Accessed on 25 March 2020 at http://www.environment.gov.au/cgi-bin/ahdb/search.pl?mode=place_detail;place_id=105180
- Department of Agriculture, Water and the Environment (2020g). Scott Reef and surrounds- Commonwealth Area, Timor Sea, EXT, Australia. Accessed on 25 March 2020 at http://www.environment.gov.au/cgi-bin/ahdb/search.pl?mode=place_detail;place_id=105480
- Department of Agriculture, Water and the Environment (2020i). HMAS Sydney II and HSK Kormoran Shipwreck Sites, Carnarvon, EXT, Australia. Accessed on 25 March 2020 at http://www.environment.gov.au/cgi-bin/ahdb/search.pl?mode=place_detail;place_id=106062

- Department of Agriculture, Water and the Environment (2020j). Home Island Foreshore, Jalan Panti, Home Island Settlement, EXT, Australia. Accessed on 25 March 2020 at http://www.environment.gov.au/cgi-bin/ahdb/search.pl?mode=place_detail;place_id=105363
- Department of Agriculture, Water and the Environment (2020k). Six-Inch Guns, Horsburgh Island, EXT, Australia. Accessed on 25 March 2020 at http://www.environment.gov.au/cgi-bin/ahdb/search.pl?mode=place_detail;place_id=105222
- Department of Agriculture, Water and the Environment (2020l). Slipway and Tank, Direction Island, EXT, Australia. Accessed on 25 March 2020 at http://www.environment.gov.au/cgi-bin/ahdb/search.pl?mode=place_detail;place_id=105221
- Department of the Environment (2019). *Sula leucogaster* in Species Profile and Threats Database, Department of the Environment, Canberra. Available from: <http://www.environment.gov.au/sprat>.
- Department of Environment (2016). EPBC Act – Protected Matters Search Tool. <http://www.environment.gov.au/erin/ert/epbc/index.html>
- Department of Environment and Conservation (2006). *Management Plan for the Montebello/Barrow Islands Marine Conservation Reserves, 2007–2015*. Management Plan No. 55. Prepared by Department of Environment and Conservation for the Marine Parks and Reserves Authority.
- Department of Environment and Conservation (2007a). *Management Plan for the Montebello/Barrow Islands Marine Conservation Reserves, 2007-2017*. Management Plan No. 55. Department of Environment and Conservation, Perth.
- Department of Environment and Conservation (2007b). *Rowley Shoals Marine Park Management Plan, 2007-2017*. Management Plan No. 56. Department of Environment and Conservation, Perth.
- Department of Environment and Conservation (2008). Shark Bay Marine Park and Hamelin Pool Marine Nature Reserve.
- Department of Environment and Conservation (2009). Marine Turtle Recovery Plan for Western Australia 2009-2016. Wildlife Management Program No. 45, Department of Environment and Conservation, Perth.
- Department of Environment and Conservation (2010a). Proposed Camden Sound Marine Park Indicative Management Plan 2010. Prepared by the Marine Policy and Planning Branch for the Marine Parks and Reserves Authority, Fremantle, Western Australia.
- Department of Environment and Conservation (2010b). Jurien Bay Marine Park.
- Department of Environment and Conservation (2011). Proposed Eighty Mile Beach Marine Park: indicative management plan. Department of Environment and Conservation Marine Parks and Reserves Authority.
- Department of Environment and Energy (2016). Specied Profile and Threats Database. Accessed on 20 November 2016 at < <http://www.environment.gov.au/cgi-bin/sprat/public/sprat.pl>>.
- Department of the Environment and Energy (2019). Approved Conservation Advice for the Tuart (*Eucalyptus gomphocephala*) woodland and forests of the Swan Coastal Plain ecological community. Accessed on 24 March 2020 at <http://www.environment.gov.au/biodiversity/threatened/communities/pubs/153-conservation-advice.pdf>
- Department of Environment and Heritage (2005a). Blue, Fin and Sei Whale Recovery Plan 2005–2010. [Online]. Department of the Environment and Heritage. Canberra, Commonwealth of Australia.
- Department of Environment and Heritage (2005b). Whale Shark (*Rhincodon typus*) Recovery Plan. Issues Paper. Canberra, Commonwealth of Australia.
- Department of Environment and Heritage (2006). Australian National Guidelines for Whale and Dolphin Watching 2005. Department of Environment and Heritage, Canberra.
- Department of Environment, Water, Heritage and the Arts (2008). The North-west Marine Bioregional Plan, Bioregional Profile: A Description of the Ecosystems, Conservation Values and Uses of the North-west Marine Region. Perth, Western Australia, Department of Environment, Water, Heritage and the Arts.
- Department of Environment, Water, Heritage and the Arts (2010). Ningaloo Coast World Heritage Nomination. Australian Department of Environment, Water, Heritage and the Arts, Canberra. Submitted to UNESCO in 2011.
- Department of Fisheries (2009). Prawn Aquaculture in Western Australia: Final ESD Risk Assessment Report for Prawn Aquaculture. Department of Fisheries, Fisheries Management Paper No. 230.
- Department of Fisheries (2011). State of the Fisheries and Aquatic Resources Report 2010/11. Fletcher W.J. and Santoro, K. (eds) Department of Fisheries.
- Department of Fisheries (2015). Status Reports of the Fisheries and Aquatic Resources of Western Australia 2014/15: The State of the Fisheries. Fletcher W.J. and Santoro, K. (eds) Department of Fisheries, Western Australia.

- Department of Industry and Resources (2007). Common Environmental Aspects of Petroleum Operations with the Potential for Environmental Impact. Department of Industry and Resources (DOIR) Environment Division Petroleum Branch, Perth.
http://www.doir.wa.gov.au/documents/environment/ED_Pet_CommonEnvAspectsOfPetOpsWithPotentialForEnvlmpact_Jan.pdf
- Department of Parks and Wildlife (2014). Marine Parks, WA. Accessed 28 March 2014.
<http://marineparks.dpaw.wa.gov.au/dive-in-to-marine-parks>
- Department of Sustainability, Environment, Water, Population and Communities (2008). Shark Bay World Heritage Area, viewed 2 October 2013 <http://www.environment.gov.au/heritage/places/world/shark-bay/information.html>
- Department of Primary Industries and Regional development (2017). Hamelin Pool Marine Nature Reserve, viewed 25 March 2020.
- Department of Sustainability, Environment, Water, Population and Communities (2011). Whale Shark (*Rhincodon typus*), Sharks in Australian Waters, Australian Government, Canberra, Viewed 20 November 2012,
<http://www.environment.gov.au/coasts/species/sharks/whaleshark/index.html>
- Department of Sustainability, Environment, Water, Population and Communities (2011a). Mermaid Reef Marine National Nature Reserve. Accessed 20 April 2012.
<http://www.environment.gov.au/coasts/mpa/mermaid/index.html>
- Department of Sustainability, Environment, Water, Population and Communities (2011b). Assessment of the Western Australian Shark Bay Crab (Interim) Managed Fishery
- Department of Sustainability, Environment, Water, Population and Communities (2012a). *Pristis zijsron*-Green Sawfish, Viewed 20 April 2012.http://www.environment.gov.au/cgi-bin/sprat/public/publicspecies.pl?taxon_id=68442
- Department of Sustainability, Environment, Water, Population and Communities (2012b). The North-west Marine Region Bioregional Plan – Bioregional Profile. Department of Sustainability, Environment, Water, Populations and Communities, Canberra, Australia
- Department of Sustainability, Environment, Water, Population and Communities (2012c). Commonwealth Marine Environment Report Card supporting the Marine Bioregional plan for the South-west Marine Region. Prepared under the *Environment Protection and Biodiversity Conservation Act 1999*. Department of Sustainability, Environment, Water, Populations and Communities, Canberra, Australia.
- Department of Sustainability, Environment, Water, Population and Communities (2013a). *Macronectes giganteus* – Southern Giant Petrel. Viewed 23 July 2013. http://www.environment.gov.au/cgi-bin/sprat/public/publicspecies.pl?taxon_id=1060
- Department of Sustainability, Environment, Water, Population and Communities (2013b). *Anous tenuirostris melanops* – Australian Lesser Noddy. Viewed 24 July 2013. http://www.environment.gov.au/cgi-bin/sprat/public/publicspecies.pl?taxon_id=26000
- Department of Sustainability, Environment, Water, Population and Communities (2013c). *Pterodroma mollis* – Soft-plumaged Petrel. Viewed 24 July 2013. http://www.environment.gov.au/cgi-bin/sprat/public/publicspecies.pl?taxon_id=1036
- Department of Sustainability, Environment, Water, Population and Communities (2013d). *Sternula nereis nereis* - Australian Fairy Tern. Viewed 24 July 2013. http://www.environment.gov.au/cgi-bin/sprat/public/publicspecies.pl?taxon_id=82950
- Department of Sustainability, Environment, Water, Population and Communities (2013e). *Thalassarche cauta cauta* – Shy Albatross, Tasmanian Shy Albatross. Viewed 24th July, < http://www.environment.gov.au/cgi-bin/sprat/public/publicspecies.pl?taxon_id=82345>
- Department of Sustainability, Environment, Water, Population and Communities (2013f). Assessment of the Western Australian Shark Bay Prawn Managed Fishery.
- Department of Sustainability, Environment, Water, Population and Communities (2013g). Assessment of the Western Australian Abrolhos Island and Mid-West Trawl Managed Fishery.
- Department of Sustainability, Environment, Water, Population and Communities (2013h). *Tursiops aduncus* (Arafura/Timor Sea populations) — Spotted Bottlenose Dolphin (Arafura/Timor Sea populations). Viewed 24 July 2013. http://www.environment.gov.au/cgi-bin/sprat/public/publicspecies.pl?taxon_id=78900
- Department of Sustainability, Environment, Water, Population and Communities (2013i). *Balaenoptera borealis* — Sei Whale. Viewed 24 July 2013. http://www.environment.gov.au/cgi-bin/sprat/public/publicspecies.pl?taxon_id=34

- Department of Sustainability, Environment, Water, Population and Communities (2013j). *Eubalaena australis* — Southern Right Whale. Viewed 24 July 2013. http://www.environment.gov.au/cgi-bin/sprat/public/publicspecies.pl?taxon_id=40
- Department of Sustainability, Environment, Water, Population and Communities (2013k). *Balaenoptera physalus* — Fin Whale. Viewed 24 July 2013. http://www.environment.gov.au/cgi-bin/sprat/public/publicspecies.pl?taxon_id=37
- Department of Sustainability, Environment, Water, Population and Communities (2013l). *Neophoca cinerea* — Australian Sea-lion. Viewed 24 July 2013. http://www.environment.gov.au/cgi-bin/sprat/public/publicspecies.pl?taxon_id=22
- Department of Sustainability, Environment, Water, Population and Communities (2013m). *Orcaella heinsohni* — Australian Snubfin Dolphin. Viewed 24 July 2013. http://www.environment.gov.au/cgi-bin/sprat/public/publicspecies.pl?taxon_id=81322
- Department of Sustainability, Environment, Water, Population and Communities (2013n). *Sousa chinensis* — Indo-Pacific Humpback Dolphin. Viewed 24 July 2013. http://www.environment.gov.au/cgi-bin/sprat/public/publicspecies.pl?taxon_id=50
- Department of Sustainability, Environment, Water, Population and Communities (2013o). Approved Conservation Advice for the Monsoon vine thickets on the coastal sand dunes of Dampier Peninsula. Assessed on 24 March 2020 at <http://www.environment.gov.au/biodiversity/threatened/communities/pubs/105-conservation-advice.pdf>
- Department of the Environment (2013a). *Balaenoptera edeni* — Bryde's Whale. Viewed 5 Feb 2014. Last updated 16 July 2013. http://www.environment.gov.au/cgi-bin/sprat/public/publicspecies.pl?taxon_id=35
- Department of the Environment (2013b). *Orcinus orca* — Killer Whale, Orca. Accessed 5 Feb 2014, Last updated 13 July 2013
- Department of the Environment (2014a). Pulu Keeling National Park. Accessed 6 February 2014. <http://www.environment.gov.au/topics/national-parks/pulu-keeling-national-park/natural-environment/marine-environment>
- Department of the Environment (2014b). Christmas Island National Park. Accessed 6 February 2014. <http://www.environment.gov.au/topics/national-parks/christmas-island-national-park>
- Department of the Environment (2014c). North-west Commonwealth Marine Reserves Network. Viewed 28 March 2014. <http://www.environment.gov.au/topics/marine/marine-reserves/north-west>
- Department of the Environment (2014d). South-west Commonwealth Marine Reserves Network. Viewed 28 March 2014. <http://www.environment.gov.au/topics/marine/marine-reserves/south-west>
- Department of the Environment (2014e). Wetlands of International Importance. Accessed 21 July 2014 <http://www.environment.gov.au/cgi-bin/wetlands/alphablist.pl>
- Department of the Environment (2014f). Ashmore Reef Commonwealth Marine Reserve. Available at <http://www.environment.gov.au/topics/marine/marine-reserves/north-west/ashmore>. Accessed 25 August 2014.
- Department of Transport (2010). Oil Spill Contingency Plan. Department of Transport, Government of Western Australia.
- Dodds W.K., Smith V.H., and Lohman, K. (2002) Nitrogen and phosphorus relationships to benthic algal biomass in temperate streams. *Can J Fish Aquat Sci* 59: 865–74.
- Dooling, R.J., and Popper, A.N. (2007). The effects of highway noise on birds. Report prepared for the California Department of Transportation, Division of Analysis. Environmental BioAcoustics LLC, Rockville, Maryland, USA. 74pp.
- Donovan, A., Brewer, D., van der Velde, T., and Skewes, T. (2008). *Scientific descriptions of four selected key ecological features (KEFs) in the north-west bioregion: final report*, a report to the Department of the Environment, Water, Heritage and the Arts, CSIRO Marine and Atmospheric Research, Hobart.
- Duke, N.C., and Burns, K.A. (1999). Fate and effects of oil and dispersed oil on mangrove ecosystems in Australia. Final project report to the Australian Petroleum Production and Exploration Association (APPEA).
- Duke, N.C., Burns, K.A., and Dalhaus, O. (1998a). Effects of oils and dispersed-oils on mangrove seedlings in planthouse experiments: a preliminary assessment of results two months after oil treatments. *Australian Petroleum Production and Exploration Association Limited Journal* 38: 631–636.
- Duke, N.C., Ellison, J.C., and Burns, K.A. (1998b). Surveys of oil spill incidents affecting mangrove habitat in Australia: a preliminary assessment of incidents, impacts on mangroves, and recovery of deforested areas. *Australian Petroleum Production and Exploration Association Limited Journal* 38: 646–654.

- Duncan, A.D., and Salgado-Kent, C. (2011). Overwater bathymetric and geophysical surveys appraisal of potential impacts on the marine environment and proposed mitigations strategies. Centre for Marine Science and Technology, Curtin University. Report prepared for Groote Resources Limited, January 2011.
- E&P Forum (1994). North Sea Produced Water: Fate and Effects in the Marine Environment. Oil Industry International Exploration and Production Forum, 1994. Report No. 2. 62/204.
- Ecotox (2012). Ecotox Services of Australia, Toxicity Assessment of a Crude Oil from the Wandoo Platform 2012, Test Report, July 2012.
- Edgar, G., and Barrett, N. (1995). Preliminary Report to the Long Term Impact Assessment Group: Program 7 Impact on and Recovery on Subtidal Reefs, Department of Primary Industry and Fisheries Tasmania.
- Ehmann, H. (1992). Reptiles. In: Strahan, R., ed. Encyclopedia of Australian Animals. Sydney.
- Encyclopedia of Life & Peter Saundry (2011). *Humpback whale*. eds. C.Michael Hogan and C.J.Cleveland, Encyclopedia of Earth, National Council for Science and Environment, Washington, DC.
- Engelhardt, F.R. (1983). Petroleum Effects on Marine Mammals. *Aquatic Toxicology*, 4, pp 199-217.
- Environmental Protection Authority (2001). Guidance for the assessment of environmental factors, guidance statement for protection of tropical arid zone mangroves along the Pilbara coastline, No. 1. Environmental Protection Authority, Perth.
- Epstein, N., Bak, R.P.M., and Rinkevich, B. (2000). Toxicity of third generation dispersants and dispersed Egyptian crude oil on Red Sea coral larvae. *Marine Pollution Bulletin* 40: 497–503.
- Etkin 2003, Determination of Persistence in Petroleum Based Oils. Report prepared for US Environmental Protection Agency Oil Program. September 2003.
- Falkner, I., Whiteway, T., Przeslawski, R. and Heap, A.D. (2009). Review of Ten Key Ecological Features (KEFs) in the North-west Marine Region. Geoscience Australia, Record 2009/13. Geoscience Australia, Canberra. 117pp.
- Fandry, C., Revill, A., Wenziker, K., McAlpine, K., Apte, S., Masini, R., and Hillman, K. (2006) Contaminants on Australia's North West Shelf: sources, impacts, pathways and effects. *NWSIEMS Technical Report No. 13*. CSIRO Marine and Atmospheric Research, Australia.
- Farmer, N., and Blew, D. (2009). Fluorescent Dye Tracer Tests at the Malad Gorge State Park. Idaho Department of Water Resources. Fingas, M.F. 2008. A Review of Literature Related to Oil Spill Dispersants Especially Relevant to Alaska 2002-2008. Prepared for Prince William Sound Regional Citizens Advisory Council Anchorage Alaska, Environment Canada.
- Fernandez-Torquemada, Y., Sanchez-Lizaso, J.L. and Gonzalez-Correa, J.M (2005). Preliminary results of the monitoring of the brine discharge produced by the SWO desalination plant of Alicante (SE Spain) *Desalination*, 182, 395-402
- Ferrier, S. (2012). 'Big-picture assessment of biodiversity change: scaling up monitoring without selling out on scientific rigour', in D Lindemayer and P Gibbons, (eds) *Biodiversity Monitoring in Australia*, CSIRO Publishing, Canberra.
- Field, M.S., Wilhelm, R.G., Quinlan, J.F., and Aley, T.J. (1995). An assessment of the potential adverse properties of fluorescent tracer dyes used for groundwater tracing. *Environmental Monitoring and Assessment* 38:75-96.
- Fingas, M.F. (2008). *A Review of Literature Related to Oil Spill Dispersants Especially Relevant to Alaska 2002-2008*. Prepared for Prince William Sound Regional Citizens Advisory Council Anchorage Alaska, Environment Canada.
- Fletcher, W.J., and Santoro, K. (eds). (2011). State of the Fisheries and Aquatic Resources Report 2010/11. Department of Fisheries, Perth, Western Australia. 359pp.
- Floyd R.F., Watson C., Petty, D., and Pouder, D.B. (2012). Ammonia in Aquatic Ecosystems. University of Florida IFAS Extension.
- Francis, M.P., Natanson, L.J., and Campana, S.E. (2008). Porbeagle (*Lamna nasus*). In: Pritchard, E.K. and Camhi M. (eds). *Sharks of the open ocean*. Blackwell Scientific Publications.
- French, D., Schuttenberg, H., and Isaji, T. (1999). Probabilities of oil exceeding thresholds of concern: examples from an evaluation for Florida Power and Light. In: Proceedings of 22nd Arctic and Marine Oil Spill Program (AMOP) Technical Seminar, June 1999, Alberta, Canada, pp. 243-270.
- French, D.P. (2000). Estimation of oil toxicity using an additive toxicity model in *Proceedings of the 23rd Arctic and Marine Oil Spill Program Technical Seminar*, Vancouver, British Columbia, Canada, pp. 561-600.
- French-McCay, D.P. (2002). Development and application of an oil toxicity and exposure model, OilToxEx. *Journal of Environmental Toxicology and Chemistry* 21: pp. 2080-2094.

- French-McCay, D.P. (2004). Oil spill impact modelling: development and validation. *Environmental Toxicology and Chemistry* 23(10):2441-2456.
- French, D.P. (2009) State of the art and research needs for oil impact assessment modelling. Proceedings of the 32nd AMOP Technical Seminar on Environmental Contamination and Response, Emergency Services Division, Environment Canada. Ottawa, ON, Canada
- Friligos, N. (1985). Turnover time of waters in a deep basin in the Aegean Sea. *Estuarine, Coastal and Shelf Science*, 21: 879-894.
- Fuller, C., Bonner, J., Page, C., Ernest, A., McDonald, T., and McDonald, S., (2004) Comparative Toxicity of Oil, Dispersant and Oil plus Dispersant to Several Marine Species.
- Gales, N., McCauley, R.D., Lanyon, J., and Holley, D. (2004). Change in abundance of dugongs in Shark Bay, Ningaloo and Exmouth Gulf, Western Australia: evidence for large-scale migration. *Wildlife Research* 31: 283-290.
- Gallaway, B.J., Martin, L.R., Howard, R.L., Boland, G.S., and Dennis G.D. (1981). Effects on artificial reef and demersal fish and macrocrustacean communities. In: Middleditch, B.S. (ed). *Environmental Effects of Offshore Oil Production: The Buccaneer Gas and Oil Field Study*, Houston, Texas: Plenum Press, New York. pp. 237-299.
- Geiling, N. (2014). Arctic Shipping: Good for Invasive Species, Bad for the Rest of Nature. *Smithsonian*. Available at: <http://www.smithsonianmag.com/science-nature/global-warnings-unexpected-consequence-invasive-species-180951573/?no-ist> (accessed 20/03/2017).
- Geraci, J.R. (1990). Physiologic and toxic effects on cetaceans. In: Geraci, J.R. and St. Aubin, D.J. (eds). *Sea Mammals and Oil. Confronting the Risks*. Pp. 167-198. New York: Academic Press.
- Geraci, J.R., and St. Aubin, D.J. (1982). Study of the effects of oil on cetaceans. Final report. Washington, D.C.: U.S. Department of the Interior, Minerals Management Service.
- Geraci, J.R., and St. Aubin, D.J. (1985). Expanded studies of the effects of oil on Cetaceans. Final report (Part I) to U.S. Department of Interior, BLM contract 14-12-0001-29169. (unpublished).
- Geraci, J.R., and St. Aubin, D.J. (1988). Synthesis of effects of oil on marine mammals, Ventura, CA, USA: US Department of the Interior, Minerals Management Service, Atlantic OCS Region, OCS Study, MMS 880049.
- Geraci, J.R., and St. Aubin, D.J. (1990). *Sea Mammals and Oil: Confronting the Risks*, Academic Press.
- Gilmour, J.P., Smith, L.D., and Brinkman, R.M. (2007). Biannual Spawning, Rapid Larval Development and Evidence of Self Seeding for Corals at Scott Reef, Proceedings of the Australian Coral Reef Society 83rd Conference, Fremantle, October 2007.
- Goodbody-Gringle, G., Wetzel, D.L., Gillon, D., Pulster, E., Miller, A. and Richie, K.B. (2013) Toxicity of Deepwater Horizon Source Oil and Chemical Dispersant Corexit 9500 to Coral Larvae. Published 09 January 2013. DOI 10.1371/journal.pone.0045574
- Gore, M.J.E. (1968). A Check-list of the birds of Sabah, Borneo. *Ibis*. 110: 165-196.
- Guamet, P.S., and Gomez De Saravia, S.G. (2005). Laboratory Studies of Biocorrosion Control using Traditional and Environmentally Friendly Biocides: An Overview.
- Guinea, M (2006), 'Sea turtles, sea snakes and dugongs of Scott Reef, Seringapatam Reef and Browse Island with notes on West Lacepede Island', unpublished report to the Department of the Environment, Water, Heritage and the Arts, Canberra.
- Guinea, M. (2007). Marine Snakes: Species Profile for the North-west Planning Area, Report for the National Oceans Office, Hobart.
- Guinea, M.L. (2007). Survey March 16 - April 2 2007: Sea snakes of Ashmore Reef, Hibernia Reef and Cartier Island with comments on Scott Reef. Final Report to the Department of the Environment and Water Resources, Canberra. Darwin: Charles Darwin University.
- Gulec, I., Leonard, B., and Holdaway, D.A. (1997). Oil and Dispersed Oil Toxicity to Amphipod sand Snails. *Spill Science and Technology Bulletin* 4:1-6.
- Gulf Coast Research Laboratory (2013). *Research Needs to Assess Oil Related Impacts on Whale Sharks in the Northern Gulf of Mexico* The University of Southern Mississippi <http://www.usm.edu/gcrl/whaleshark/oil.impact.php>
- Hale, J. (2010). Ecological Character Description for the Pulu Keeling National Park Ramsar Site. Report to the Department of Sustainability, Environment, Water, Population and Communities, Canberra.
- Hale, J. and Butcher, R. (2009). Ecological Character Description of the Eighty-mile Beach Ramsar Site, Report to the Department of Environment and Conservation, Perth, Western Australia.
- Hale, J. and Butcher, R. (2010). Ecological Character Description for Hosnies Spring Ramsar Site. Report to the Department of Sustainability, Environment, Water, Population and Communities, Canberra.

- Hale, J. and Butcher, R. (2013). Ashmore Reef Commonwealth Marine Reserve Ramsar Site Ecological Character Description. A report to the Department of the Environment, Canberra.
- Hamann, M., Limpus, C., Hughes, G., Mortimer, J., and Pilcher, N. (2006). Assessment of the conservation status of the leatherback turtle in the Indian Ocean and South East Asia. Bangkok: IOSEA Marine Turtle MoU Secretariat.
- Harrison, P.L. (1999). Oil pollutants inhibit fertilisation and larval settlement in the scleractinian reef coral *Acropora tenuis* from the Great Barrier Reef, Australia. In: Sources, Fates and Consequences of Pollutants in the Great Barrier Reef and Torres Strait: Conference Abstracts. Great Barrier Reef Marine Park Authority, Townsville
- Harrison, P.L., Babcock, R.C., Bull, G.D., Oliver, J.K., Wallace, C.C., and Willis, B.L. (1984). Mass spawning in tropical reef corals. *Science* 223:1186-1189.
- Hatcher, A.L., and Larkum, A.W.D. (1982). The effects of short-term exposure to Bass Strait crude oil and Corexit 8667 on benthic community metabolism in *Posidonia australis* dominated microcosms. *Aquatic Botany*, 12: 219–227
- Heinsohn, G.E., Marsh, H., and Anderson, P.K. (1977). Australian dugong. *Oceans Vol. 12*(3):48-52.
- Hemmer, M.J., Barron, M.G., and Greene R.M. (2011). Comparative toxicity of eight oil dispersants, Louisiana sweet crude oil (LSC) and chemically dispersed LSC to two aquatic test species. *Environmental Toxicology and Chemistry* 30, 2244-2252.
- Heyward, A.J., Farrell, P.D., and Seemark, R.F. (1994). The effect of petroleum based pollutants on coral gametes and fertilisation success. In: *Sixth Pacific Congress on Marine Science and Technology*, p.119, Townsville, Australia.
- Holdway, D. (2002). The acute and chronic effects of wastes associated with offshore oil and gas production on temperate and tropical marine ecological processes. *Marine Pollution Bulletin*, 44 (3), 185-203.
- Holmberg, J., Norman, B., and Arzoumanian, Z. (2009). Estimating population size, structure and residency time for whale sharks *Rhincodon typus* through collaborative photo-identification. *Endangered Species Research* 7, 39-53.
- Hopper S and Gioia P (2004). The southwest Australian floristic region: Evolution and conservation of a global hot spot of biodiversity. *Annual Review of Ecology, Evolution, and Systematics*, 35: 623–50.
- Hoyt, E. (2012). *Marine Protected Areas for Whales, Dolphins and Porpoises: A World Handbook for Cetacean Habitat Conservation and Planning*, 2nd Edition. Earthscan, Oxon, UK.
- Huisman, J.M. (2004). Marine benthic flora of the Dampier Archipelago, Western Australia. *Records of the Western Australian Museum*. Supplement No. 66: 61-68.
- Huisman, J.M., and Borowitzka, M.A. (2003) Marine benthic flora of the Dampier Archipelago, Western Australia. In F.E. Wells, D.I. Walker and D.S. Jones (eds.) *The Marine Flora and Fauna of Dampier, Western Australia*. Western Australian Museum, Perth.
- IMCA (2010). Guidance on the Transfer of Personnel to and from Offshore Vessels SEL 025, IMCA M 202. International Marine Contractors Association. March 2010.
- Integrated Fisheries Allocation Advisory Committee (2013). West Coast Demersal Scalefish Allocation Report. Fisheries Management Paper No. 249. Prepared by the Integrated Fisheries Allocation Advisory Committee for the Minister for Fisheries. Department of Fisheries, WA, July 2013.
- Intertek (2019) *Ecotoxicology Laboratory Test Report: Ecotoxicity Testing of the Wandoo Crude Oil Water Accommodated Fraction* (Report # 65936)
- Intertek Geotech (2012). *An Assessment of Dispersion Efficacy on a Crude Oil: Professional Opinion*, Prepared for Vermilion Gas and Gas Australia Pty Ltd.
- IPIECA (2008). Oil Spill preparedness and response: report series summary, IPIECA Report Series 1990-2008, United Kingdom.
- Iqomah, M. (2004). Basic study of sea turtle observation in Alas Purwo National Park, Banyuwangi, East Java. KMPV Pet and Wild Animal of Veterinary Medicine Faculty of Airlangga University, Surabaya.
- IRC Environment (2004). Blacktip Produced Formation Water Assessment. Produced for Woodside Energy Australia.
- ITOPF(2011) Clean-up of oil from shorelines. Technical information paper.
- ITOPF (2013). The international tanker owners pollution federation limited Containment and Recovery <http://www.itopf.com/spill-response/clean-up-and-response/containment-and-recovery/>
- IUCN (2011). The IUCN Red List of Threatened Species: Manta birostris. Accessed 5 Feb 2014. Last updated 1 November 2011. <http://www.iucnredlist.org/details/198921/0>
- IWC (2009). Country report on ship strikes: Australia. Report to the International Whaling Commission (IWC) Conservation Committee. IWC/61/CC3, 1pp.
- IWC (2010). Country report on ship strikes: Australia. Report to the International Whaling Commission (IWC) Conservation Committee. IWC/62/CC4, 1pp.

- IWC (2011). Country report on ship strikes: Australia. Report to the International Whaling Commission (IWC) Conservation Committee. IWC/63/CC12, 1pp.
- Jackson, J.B.C., Cubit, J.D., Keller, B.D., Batista, V., Burns, K., Caffey, H.M., Caldwell, R.L., Garrity, S.D., Getter, C.D., Gonzales, C., Guzman, H.M., Kaufman, K.W., Knap, A.H., Levings, S.C., Marshall, M.J., Steger, R., Thompson, R.C., and Weil, E. (1989). Ecological effects of a major oil spill on Panamanian coastal marine communities. *Science*, 243: 37–44.
- Jacobs, R.P.W.M., Grant, R.O.H., Kwant, J., Marqueine, J.M., and Mentzer, E. (1992). The Composition of Produced Water from Shell Operated Oil and Gas Production in the North Sea. In: Ray, J.P. and Englehart, F.R. (eds.), *Produced Water*, Plenum Press, New York.
- Jenne, E.A., and Luoma, S.N. (1977). Forms of trace elements in soils, sediments and associated waters: an overview of their determination and biological availability. In: Wildung, R.E. and Drucker, H. (eds). *Biological implications of metals in the environment*. Pp. 110-143.
- Jenner, K.C.S., and Jenner, M-N.M. (2008). Browse Basin Cetacean Monitoring Programme 2007 Season Report. Unpublished report to Inpex Browse Pty Ltd and the Department of Environment, Water, Heritage and the Arts. 32pp.
- Jenner, K.C.S., Jenner, M-N., and McCabe, K.A. (2001). Geographical and temporal movements of humpback whales in Western Australia waters. *APPEA Journal* 38(1): 692-707.
- Jenssen, B.M. (1994). Review article: Effects of oil pollution, chemically treated oil and cleaning on the thermal balance of birds. *Environmental Pollution* 86: 207–215.
- Jones H.E. (1986). Marine Resources Map of Western Australia: Part 2- The Influence of Oil on Marine Resources and Associated Activities with Emphasis on Those found in Western Australia. Report No 74, Fisheries Department of Western Australia, Perth.
- Jones, D.S. (2004). Report on the results of the Western Australia Museum/Woodside Energy Ltd. Partnership to explore the Marine Biodiversity of the Dampier Archipelago, Western Australia 1998-2002. *Records of the Western Australian Museum, Supplement* 66:1-401.
- Kangas, M., Sporer, E., Brown, S., Shanks, M., Chandrapavan, A., and Thomson, A. (2011). Stock Assessment for the Shark Bay Scallop Fishery. Fisheries Research Report No. 226. Department of Fisheries, Western Australia. 76pp
- Kato, H. (2002). Bryde's Whales *Balaenoptera edeni* and *B. brydei*. In: Perrin W.F., B. Wrsig & H.G.M. Thewissen, eds. *Encyclopedia of Marine Mammals*. Page(s) 171-177. Academic Press.
- Ke, L., Zhang, C.G. Wong, Y.S, and Tam, N.F.Y. (2013). Dose and accumulative effects of spent lubricating oil on four mangrove plants. *Ecotoxicology and Environmental Safety* 74, 55-66
- Keesing, J.K., Irvine, T.R., Alderslade, P., Clapin, G., Fromont, J., Hosie, A.M., Huisman, J.M., Phillips, J.C., Naughton, K.M., Marsh, L.M., Slack-Smith, S.M., Thomson, D.P., and Watson, J.E. (2011). Marine benthic flora and fauna of Gourdon Bay and the Dampier Peninsula in the Kimberley region of north-western Australia. *Journal of the Royal Society of Western Australia* 94: 285-301.
- Kent, D.B., Leatherwood, S., and Yohe, L. (1983). Responses of migrating gray whales, *Eschrichtius robustus*, to oil on the sea surface - results of a field evaluation. Final Report, Contract P-0057621, to the Department of Pathology, Ontario Veterinary College, University of Guelph, Guelph, Ontario, Canada N16 2WA. 63pp.
- King, B., and McAllister, F.A. (1997). Modelling the Dispersion of Produced Water Discharge in Australia 1&2. Australian Institute of Marine Science report to the APPEA and ERDC.
- Kinhill (1997). East Spar First Post-commissioning Survey Report. A report to Apache Energy by Kinhill Pty Ltd. October 1997. Report EA-00-RI-9981/B.
- Klimley, A.P., and Anderson, S.D. (1996). Residency patterns of white sharks at the South Farallon Islands, California. pp. 365-373 in Klimley, A.P. and D.G. Ainley (Eds.), *Great White Sharks: The Biology of Carcharodon carcharias*. Academic Press, San Diego, 528 pp.
- Knap, A.H., Sleeter, T.D., Dodge, R.E., Wyers, S.C., Frith, H.R. and Smith, S.R. (1985). The effects of chemically and physically dispersed oil on the brain coral *Diploria strigosa* (Dana)—a summary review.
- Koops, W., Jak, R.G., and van der Veen, D.P.C. (2004). 'Use of dispersants in oil spill response to minimize environmental damage to birds and aquatic organisms', paper presented at the *Interspill 2004*, 14-17 June 2004
- Krabbenhoft, R.W., Weinrebe, H., Kopp, E.R., Flueh, S., Ladage, C., Papenberg, L., Planert, and Djajadihardja, Y. (2010). Bathymetry of the Indonesian Sunda margin-relating morphological features of the upper plate slopes to the location and extent of the seismogenic zone. *Nat. Hazards Earth Syst. Sci.*, vol. 10, pp. 1899–1911

- Kucklick, J.H., Walker, A.H, Pond, R., and Aurand, D., eds. (1997). *Dispersant use: Considerations of Ecological Concern in the Upper 10 Meters of Marine Waters and in Shallow Coastal Waters*. Prepared for the Marine Preservation Association, Scottsdale AZ, Scientific and Environmental Associates, Inc., Alexandria VA
- Kuta Beach Sea Turtle Conservation (2014). Meru Betiri National Park webpage. Accessed 5 Feb 2014: <http://www.kutaseaturtle.com/2010/11/meru-betiri-national-park.html>
- Lambert, G., Peakall, D.B, Philogene B.J.R., and Engelhardt F.R. (1982). Effect of oil and dispersant mixtures on basal metabolic rate of ducks. *Bulletin of Environmental Contamination and Toxicology* 29:520-524
- Lance, B.K., Irons, D.B., Kendall, C.J., and McDonald, L.L. (2001). An evaluation of marine population trends following the 'Exxon Valdez' oil spill, Prince William Sound, Alaska. *Marine Pollution Bulletin*, 42(4): 298–309
- Lane, A., and Harrison, P.L. (2000). Effects of oil contaminants on survivorship of larvae of the scleractinian reef corals *Acropora tenuis*, *Goniastrea aspera* and *Platygyra sinensis* from the Great Barrier Reef. Proceedings 9th International Coral Reef Symposium, Bali, Indonesia 23-27 October 2000.
- Last, P.R., and J.D. Stevens (2009). *Sharks and Rays of Australia (Second Edition)*. Collingwood, Victoria: CSIRO Publishing.
- Latterman, S. (2010). Development of an Environmental Impact Assessment and Decision Support System for Seawater Desalination Plants. Florida, Taylor and Francis Group.
- Limpus, C. (2009). *A biological review of Australian marine turtle species*. Environmental Protection Agency, Queensland.
- Limpus, C.J. (1997). Marine turtle populations of Southeast Asia and the western Pacific Region: distribution and status. In: Noor, Y. R., I. R. Lubis, R. Ounsted, S. Troeng, A. Abdullah, ed. Proceedings of the Workshop on Marine Turtle Research and Management in Indonesia. Jember, East Java, November 1996. Page(s) 37-72. Bogor: Wetlands International/PHPA/ Environment Australia.
- Limpus, C.J., Miller, J.D., Parmenter, C.J., Reimer, D., McLachlan, N., and Webb, R. (1992). Migration of green (*Chelonia mydas*) and loggerhead (*Caretta caretta*) turtles to and from eastern Australian rookeries. *Wildlife Research* 19, 347-358.
- Lin, Q. and Mendelsohn, I.A. (1996). A comparative investigation of the effects of Louisiana crude oil on the vegetation of fresh, brackish, and salt marsh. *Marine Pollution Bulletin* 32: 202–209.
- Lindquist D., Shaw, R., and Hernandez, F. (2005). Distribution patterns of larval and juvenile fishes at offshore petroleum platforms in the north-central Gulf of Mexico. *Estuarine, Coastal and Shelf Science* Vol. 62:655–665.
- Long, E.R., MacDonald, D.D., Smith, S.L., and Calder, F.D. (1995). Incidence of adverse biological effects within ranges of chemical concentrations in marine and estuarine sediments. *Environmental Management* 19: 81-97.
- Lunel, T., and Lewis, A. (1999). Optimisation of Oil Spill Dispersant Use. Proceedings, 1999 International Oil Spill Conference. American Petroleum Institute, Washington DC, pp 187-193.
- Luoma, S.N., and Rainbow, P.S. (2005). Why is metal bioaccumulation so variable? Biodynamics as a unifying concept. *Environmental Science and Technology* 39(7): 1921-1931.
- Marchant, S., and Higgins, P.J., eds. (1990). *Handbook of Australian, New Zealand and Antarctic Birds. Volume One - Ratites to Ducks*. Melbourne, Victoria: Oxford University Press.
- Marquenie, J., Donners, M., Poot, H., Steckel, W., de Wit, B., and Nam, A. (2008). Adapting the spectral composition of artificial lightning to safeguard the environment, Petroleum and Chemical Industry Conference Europe - Electrical Instrumentation Applications. 5th PCIC Europe, pp 1-6.
- Marsh, H., Penrose, H., Eros, C., and Hugues, J. (2002). Dugong Status Report and Action Plans for Countries and Territories. United Nations Environment Programme, Nairobi.
- Mau, R., and Balcazar, N. (2007). Progress Report: Establishing Turtle Nesting Activity for Serrurier Island Nature Reserve, Locker Island Nature Reserve and Locker Point to the Ashburton River, North Western Australia. Department of Environment and Conservation, Western Australia.
- McAuliffe, C.D. (1987). Organism exposure to volatile hydrocarbons from untreated and chemically dispersed oils in field and laboratory: in Proc. Ninth Arctic Marine Oil Spill Program Tech. Sem., pp. 497-526.
- McCauley, R., Bannister, J., Burton, C., Jenner, C., Rennie, S., and Salgado-Kent, C. (2004). Western Australian Exercise Area Blue Whale Project. Final summary report, Milestone 6. Report produced for Australian Defence.
- McCauley, R., Fewtrell, J., Duncan, A., Jenner, C., Jenner, M., Penrose, J., Prince, R., Adhitya, A., Murdoch, J., and McCabe, K.A. (2000). Marine Seismic Surveys – A study of environmental implications. *APPEA Journal*. pp 692-706

- McCauley, R.D. (1994). Seismic Surveys. The environmental implications of offshore oil and gas development in Australia – In: The Environmental Implications of Offshore Oil and Gas Development in Australia – the Findings of an Independent Scientific Review.
- McCauley, R.D. (1998). Radiated underwater noise measured from the drilling rig Ocean General, rig tenders Pacific Ariki and Pacific Frontier, fishing vessel Reef Venture and natural sources in the Timor Sea, Northern Australia. Report to Shell Australia.
- McCosker, J.E. (1975). Feeding behaviour of Indo-Australian Hydrophiidae. In: Dunson, W.A. (ed). The Biology of Sea Snakes. Pp 217-232. Baltimore: University Park Press.
- Meekan, M.G., Wilson, S.G., Halford, A., and Retzel, A. (2001). A comparison of catches of fishes and invertebrates by two light trap designs, in tropical NW Australia. Marine Biology. Vol 139, pg 373–381.
- Meike, S., Castro, C., Gonzalez, J., and Williams, R. (2004). Behavioural responses of humpback whales (*Megaptera novaeangliae*) to whale watching boats near Isla de la Plata, Machalilla National Park, Ecuador, Journal of Cetacean Research and Management, vol. 6, no. 1, pp. 63-68.
- Miller, D.C., Poucher, S., Cardin, J.A., and Hansen, D. (1990). The acute and chronic toxicity of ammonia to marine fish and a mysid, Archives of Environmental Toxicology, 19, 40-48.
- Mitchell, F.M., and Holdaway, D.A. (2000). The acute and chronic toxicity of the dispersants.
- Mollet, H.F., Cliff, G., Pratt Jr, H.L., and Stevens, J.D. (2000). Reproductive biology of the female shortfin mako, *Isurus oxyrinchus Rafinesque*, 1810, with comments on the embryonic development of lamnoids. Fishery Bulletin 98:299-318.
- Myrberg Jr, A.A. (1996). Fish bioacoustics: Serendipity in research. Bioacoustics 7:143-150.
- Nagelkerken, I., Blaber, S.J.M., Bouillon, S., Green, P., Haywood, M., Kirton, L.G., Meynecke, J.-O., Pawlik, J., Penrose, H.M., Sasekumar, A., and Somerfield, P.J. (2008). The habitat function of mangroves for terrestrial and marine fauna: A review. *Aquatic Botany* 89: 155-185.
- NAP (2005). Oil Spill Dispersants: Efficacy and Effects, Committee on Understanding Oil Spill Dispersants: Efficacy and Effects, National Research Council, Washington DC.
- National Environmental and Scientific Coordinators (ESC) Workshop and the National Plan Environment Working Group (2007). Foreshore Assessment, Termination of Clean-up and Rehabilitation Monitoring Plan. Australian Maritime Safety Authority.
- National Heritage Trust (2002). Ashmore Reef National Nature Reserve and Cartier Island Marine Reserve Management Plans.
- National Marine Fisheries Service (2001). Fisheries Statistics and Economics Division, Silver Spring, MD. NOAA. 2012. Impacts of Oil on Marine Mammals and Sea Turtles, NOAA Fisheries Services.
- National Research Council (1989). Using Oil Dispersant on the Sea. The National Academy Press, Washington D.C.
- Neff, J., Lee, K. and DeBlois, E.M. (2011). Produced Water: Overview of composition, fates, and effects. In: Lee, K. and Neff, J. (Eds.). Produced Water. Springer, New York (Chapter 1).
- Neff, J.M. (2002). Bioaccumulation in marine organisms: effect of contaminants from oil well produced water. New York: Elsevier. 452 pp.
- Negri, A.P., and Heyward, A.J. (2000). Inhibition of fertilization and larval metamorphosis of the coral *Acropora millepora* (Ehrenberg, 1834) by petroleum products. Marine Pollution Bulletin 41: pp. 420-427.
- Nelson, J.B., and Powell, D. (1986). The breeding ecology of Abbott's Booby. Emu. 86: 33-46
- Nicholls, N. (1992). Recent performance of a method for forecasting Australian seasonal tropical cyclone activity. *Australian Meteorological Magazine* 40: 105-110.
- Nixon, S.C., Gunby, A., Ashley, S.J., Lewis, S., and Naismith, I. (1995). Development and testing of General Quality Assessment schemes: Dissolved oxygen and ammonia in estuaries. Environment Agency R&D Project Record PR 469/15/HO.
- NOAA (2012). Impacts of Oil on Marine Mammals and Sea Turtles, NOAA Fisheries Services.
- NOAA (2014). NOAA Coral Reef Conservation Program 23 January 2014
http://coralreef.noaa.gov/aboutcrp/news/featuredstories/may10/oilspill_coral/welcome.html
- NRC (1985). Oil in the Sea: Inputs, Fates and Effects. National Academic Press, Washington, DC
- Ober, H.K. (2010). Effects of Oil Spills on Marine and Coastal Wildlife, Florida.
- OGP (2005). Fates and effects of naturally occurring substances in produced water on the marine environment. Report No. 364. International Association of Oil and Gas Producers, February 2005.
- Olsen, K. (1990). Fish behaviour and acoustic sampling. Raupp.P-v.Reun.Cons. int. Explor. Mer 189: 147-158.

- Orth, R.J., Harwell, M.C., and Inglis, G.J. (2006). Ecology of seagrass seeds and dispersal strategies. In A.W.D. Larkum, R.J. Orth and C.M. Duarte (eds.) *Seagrasses: Biology, Ecology and Conservation*. Springer, Dordrecht.
- Parks Australia North (2004). Nationally threatened species and ecological communities fact sheet: Round Island Petrel (*Pterodroma arminjoniana*), North Keeling Island.
- Parra, G.J., Preen, A.R., Corkeron, P.J., Azuma, C., and Marsh, H. (2002). Distribution of Irrawaddy dolphins, *Orcaella brevirostris*, in Australian waters. *Raffles Bulletin of Zoology*. 10:141-154.
- Parry G.D., and Gason, A. (2006). The effect of seismic surveys on catch rates of rock lobsters in western Victoria, Australia. *Fisheries Research*, 79:272-284.
- Payne, J.F. (1992). Oil pollution: too much horribilising and catastrophising'. In: Ryan, P.M. (ed), 1993. *Managing the Environmental Impact of Offshore Oil Production*. Canadian Society of Environmental Biologists. St Johns Newfoundland, Canada.
- Peakall, D.B., Wells, P.G., and Mackay, D. (1987). A hazard assessment of chemically dispersed oil spills and seabirds. *Marine Environmental Research* 22:91-106.
- Pearce, A., Buchan, S., Chiffings, T., D'Adamo, N., Fandry, C., Fearn, P., Mills, D., Phillips, R., and Simpson, C. (2003). A review of the oceanography of the Dampier Archipelago, Western Australia. In F.E. Wells, D.I. Walker and D.S. Jones (eds.) *The Marine Flora and Fauna of Dampier, Western Australia*. Western Australian Museum, Perth.
- Pearson, W.H., Skalski, J.R., and Malme, C.I. (1992). Effects of sounds from a geophysical survey device on the behaviour of captive rockfish (*Sebastes* spp.) *Can. J. Fish. Aquatic Sci.* 49(7): 14343-56.
- Peckol, P., Levings, S.C., and Garrity, S.D. (1990). Kelp response following the World Prodigy oil spill. *Marine Pollution Bulletin* 21:473-476.
- Pedretti, Y.M., and Paling, E.I. (2000). *WA Mangrove assessment project 1999-2000*. Marine and Freshwater Research Laboratory, Perth.
- Pendoley, K. (1997). Sea turtles and management of marine seismic programs in Western Australia. *Petroleum Exploration Society of Australia Journal* 23: 8-16.
- Pendoley, K. (2005). Sea turtles and the Environmental Management of Industrial Activities in North West Western Australia. PhD thesis, Murdoch University, Perth.
- Peters, E.C., Meyers, P.A., Yevich, P.V., and Blake, N.J. (1981). Bioaccumulation and histopathological effects of oil on a stony coral. *Marine Pollution Bulletin* 12(10):333-339;
- Piatt, J.F., Lensink, C.J., Butler, W.B., Kendziorek, M., and Nysewander, D.K. (1990). Immediate impact of the 'Exxon Valdez' oil spill on marine birds. *Auk*, 107:387-397
- Plotkin, P. (2003). Adult migrations and habitat use. In P.L. Lutz, J.A. Musick and J. Wyneken (eds.) *The Biology of Sea Turtles Volume II*. CRC Press, Boca Raton.
- Proceedings 1985 Oil Spill Conference, API Publication Number 4385, American Petroleum Institute, Washington D.C., 547-551
- Radniecki, T.S., Schneider, M.C., and Semprini, L. (2013). The influence of Corexit 9500A and weathering on Alaska North Slope crude oil toxicity to the ammonia oxidizing bacterium, *Nitrosomonas europaea*. *Marine Pollution Bulletin* Vol. 68(1-2):64-70.
- Rainer, S.F. (1991). High species diversity in demersal polychaetes of the North West Shelf of Australia. *Ophelia Suppl.*, 5: 497-505.
- Ralph, P.J., and Burchett, M.D. (1998). Impact of petrochemicals on the photosynthesis of *Halophila ovalis* using chlorophyll fluorescence. *Marine Pollution Bulletin* 36(6), 429-436.
- Raventos, N., Macpherson, E., and Garcia-Rubies, A. (2006). Effect of brine discharge from a desalination plant on microbenthic communities in the NW Mediterranean. *Marine Environmental Research*, 62, 1-14.
- Reid, J.R., and B.M. Hill (2005). Recent Surveys of the Cocos Buff-banded Rail. CRES ANU, Canberra.
- Reid, J.R.W. (2000). Survey of the Buff-banded Rail (*Gallirallus philippensis andrewsi*) in Pulu Keeling National Park, Cocos Islands, Indian Ocean. Author, Canberra.
- Richardson, W.J., Greene Jnr, C.R., Malme, C.I., and Thomson, D.H. (1995). *Marine Mammals and Noise*. Academic Press, California.
- Rico-Martínez, R., Snell, T.W., and Shearer, T.L. (2013). Synergistic toxicity of Macondo crude oil and dispersant Corexit 9500A® to the *Brachionus plicatilis* species complex (Rotifera). *Environmental Pollution* 173:5-10, <http://dx.doi.org/10.1016/j.envpol.2012.09.024>
- Rinkevich, B., and Loya, Y. (1977). Harmful effects of chronic oil pollution on a Red Sea coral population. In: Taylor, D.L. (ed), *Proceedings Third International Coral Reef Symposium II*. Geology. University of Miami. Pp. 585-591.

- Rogers, D.I., Hassell, C.J., Boyle, A., Gosbell, K., Minton, C., Rogers, K.G., and Clarke, R.H. (2011). Shorebirds of the Kimberley coast – populations, key sites, trends and threats. *Journal of the Royal Society of Western Australia* 94: 377-391.
- Ross, J.P. (1998). *Crocodiles: Status Survey and Conservation Action Plan*. Second Edition. IUCN/SSC Crocodile Specialist Group. IUCN, Gland.
- Ross, S.L. (2002). Assessment of the Use of Dispersants on Oil Spills in California Marine Waters, S.L. Ross Environmental Research Ltd, Ottawa.
- Rosser, N.L., and Gilmour, J.P. (2008). New insights into patterns of coral spawning on Western Australian reefs. *Coral Reefs* 27: 345-349.
- RPS (2009). INPEX Environmental Impact Assessment Studies — Supplementary Report: Marine Turtle Studies 2007–2008. Prepared by RPS Environment and Planning Pty Ltd for INPEX Browse Ltd, Perth.
- RPS (2010). *Wheatstone Project EIS/ERMP: Technical Appendix — Marine Turtles*. Prepared by RPS Environment and Planning Pty Ltd for Chevron Australia, Perth.
- RPS (2012). OSCP Environmental Sensitivities Summary. Wandoo B Production Facility. Unpublished report prepared for Vermilion Oil & Gas Australia.
- Rye, H., Reed, M., Melbye, A., and Johnsen, S. (1996). An intercomparison between field measurements and three different calculation models for the estimation of dilution factors. Proc. Int. Produced Water Seminar, p. 25-28, September 1995, Trondheim, Norway. Plenum Press, New York.
- Scholten, MCTh Kaag, NHBM, Dokkum, HP Jak, RG Schobben, HPM and Slob, W., 1996, Toxische effecten van olie in het aquatische milieu, TNO report TNO-MEP – R96/230, Den Helder, The Netherlands
- Scholz, D., Michel, J., Shigenaka, G., and Hoff, R. (1992). Biological resources. In: An Introduction to Coastal habitats and Biological Resources for Oil Spill Response. Report HMRAD 92-4 pp (4)-1-66. NOAA Hazardous Materials Response and Assessment Division, Seattle.
- Schuler, P.A., and Bacer, B. (2006), Net Environmental Benefit Analysis (SIMA) Of Dispersed Oil Versus Non-Dispersed Oil On Coastal Ecosystems & Wildlife Utilizing Data Derived From The 20-Year Tropics Study, Florida.
- Seager, J., Wolff, E.W., and Cooper, V.A. (1988). Proposed environmental quality standards for List II substances in water. Ammonia. WRc report No TR260.
- Semeniuk, V. (1986). Terminology for geomorphic units and habitats along the tropical coast of Western Australia. *Journal of the Royal Society of Western Australia*. Volume 63, Issue 3, pp 53-79
- Semeniuk, V. (1993). The Pilbara coast: a riverine coastal plain in a tropical arid setting, northwestern Australia. *Sedimentary Geology* 83: 235-256.
- Semeniuk, V. (1997). Selection of Mangrove Stands for Conservation in the Pilbara Region of Western Australia – a Discussion 30th June 1997 (updated 28th July 1997). Unpublished report to the Department of Resources Development. V & C Semeniuk Research Group, Perth.
- Sepulveda, C.A., Kohin, S., Chan, C., Vetter, R., and Graham, J.B. (2004). Movement patterns, depth preferences, and stomach temperatures of free-swimming juvenile mako sharks, *Isurus oxyrinchus*, in the Southern California Bight. *Marine Biology* 145:191–199.
- Sheppard, J.K., Marsh, H., Jones, Eyeh, R., and Lawler, I.R. (2010). Dugong habitat use in relation to seagrass nutrients, tides and diel cycles. *Marine Mammal Science* 26: 855-879.
- Shingenaka, G., Yender, R.A., Mearns, A., and Hunter, C.L. (2010). Oil Spills in Coral Reefs: Planning and Response Considerations, US Department of Commerce.
- Shire of Roebourne (2013) Point Samson Foreshore Management Plan. Prepared for Shire of Roebourne by Essential Environmental August 2013
- Simmonds, M., Dolman, S., and Weilgart, L., eds. (2004). Oceans of Noise. A Whale and Dolphin Conservation Society Science Report, Wiltshire.
- Simpson, C.L., Cary, J.L., and Masini, R.J. (1993). Destruction of corals and other reef animals by coral spawn slicks on Ningaloo Reef, Western Australia. *Coral Reefs* 12: 185-191.
- Sinclair Knight Merz (1998). Mobil Wandoo Sampling. Prepared by SKM for Mobil Exploration and Producing Australia Pty Ltd.
- Smith, H. (2003) Eutrophication of freshwater and coastal marine ecosystems; a global problem. *Environ Sci. Pollut. R.* 10: 126-39.
- Smith, T.G., Geraci, J.R., and St. Aubin, D.J. (1983). Reaction of bottlenosed dolphins, *Tursiops truncatus*, to a controlled oil spill. *Canadian Journal of Fisheries and Aquatic Science* 40(9):1522–1525

- Southall, B.L., Bowles, A.E., Ellison, W.T., Finneran, J.J., Gentrey, C.R., Greene Jr, C.R., Kastak, D., Ketten, D.R., Miller, J.H., Nachtigall, P.E., Richardson, W.J., Thomas, J.A., and Tyack, P.L. (2007). Marine Mammal Noise Exposure Criteria: Initial Scientific Recommendations. Jeanette A. Thomas. Aquatic Mammals. Volume 33, No 4
- Spies, R.B. (1987). The biological effects of Petroleum Hydrocarbons in the Sea: Assessments from the Field and Microcosms. Long-Term Environmental Effects of Offshore Oil and Gas Development. Boesch and Rabalais, eds Elsevier Applied Science, New York, NY. Pp. 411-467
- Spotila, J.R. (2004). Sea Turtles: A Complete Guide to their Biology, Behavior, and Conservation. The John Hopkins University Press, Baltimore.
- Spring, C.S. (1982). Status of marine turtle populations in Papua New Guinea. In: Bjorndal, K. A., ed. Biology and Conservation of Sea Turtles. Page(s) 281-289. Washington D. C., Smithsonian Institute Press.
- Stagg, H.M.J. (1978). The geology and evolution of the Scott Plateau. The APEA Journal 18, 34-48.
- Stevens, J.D., Bradford, R.W., and West, G.J. (2010). Satellite tagging of blue sharks (*Prionace glauca*) and other pelagic sharks of eastern Australia: depth behaviour, temperature experience and movements. *Marine Biology* 157: 575-591.
- Stevens, J.D., Pillans, R.D., and Salini, J. (2005). Conservation assessment of *Glyphis sp. A* (spartooth shark), *Glyphis sp. C* (northern river shark), *Pristis microdon* (freshwater sawfish) and *Pristis zijsron* (green sawfish). Final Report to the Department of the Environment and Heritage, Canberra, Commonwealth of Australia.
- Stevens, L., and Aurand, D. (2008). Criteria for Evaluating Oil Spill Planning and Response Operations. A Report to IUCN, The World Conservation Union. Ecosystem Management & Associates, Inc., Lusby, MD. 20657. Technical Report 07-02 (Revised June 2008), 55p.
- Stoddart, J.A., and Gilmour, J. (2005). Patterns of reproduction of in-shore corals of the Dampier Harbour, Western Australia, and comparisons with other reefs. In J.A. Stoddart and S.E. Stoddart (eds.) *Corals of the Dampier Harbour: Their Survival and Reproduction During the Dredging Programs of 2004*. MScience Pty Ltd, Perth.
- Stokes, T. (1988). A review of the birds of Christmas Island, Indian Ocean. Australian National Parks and Wildlife Service Occasional Paper.
- Storr, G.M., Smith, L.A., and Johnstone, R.E. (2002) Snakes of Western Australia. Perth: Western Australia: Western Australian Museum
- Sumner, NR Williamson, PC Malseed, BE 2002, *A 12-Month Survey of Recreational Fishing in the Gascoyne Bioregion of Western Australia During 1998-1999*. Government of Western Australia. Fisheries Research Report No 139.
- Surman, C. (2002). Survey of the marine avifauna at the Laverda-2 appraisal well (WA-271-P) Enfield Area Development and surrounding waters. Report prepared for Woodside Energy Ltd., Perth.
- Suwelo, I.S. (1999). Olive Ridley Turtle Records from South Banyuwangi, East Java. Centre for Education and Training of Forestry Personnel, Jalan Gunung Batu, Indonesia.
<http://www.seaturtle.org/mtn/archives/mtn85/mtn85p9.shtml>
- Swan, J.M., Neff, J.M., and Young, P.C. (Eds) (1994). Environmental Implications of Offshore Oil and Gas Development in Australia – The Findings of an Independent Scientific Review. Australian Petroleum Exploration Association (APEA), Sydney. Pp. 209-407.
- Taub, Frieda B. (2004), Fish 430 lectures (Biological Impacts of Pollutants on Aquatic Organisms), University of Washington College of Ocean and Fishery Sciences, Seattle, WA.
- Teal, J.M., and Howarth, R.W. (1984). Oil spill studies: a review of ecological effects. *Environmental Management*, Vol .8, pp. 27-44.
- Terrens, G.W., and Tait, R.D. (1996). Effects on the Marine Environment of Produced Formation Water Discharges from Offshore Development in Bass Strait, Australia. *Society of Petroleum Engineers*, 4 (2), 42-50.
- Thorhaug, A., Marcus, J., and Booker, F. (1991). Dispersant use for tropical nearshore water; Jamaica. In: Proceedings of International Oil Spill Conference, San Diego, 1991. pp415–418
- Timuraya. (2006). Sulphamic Acid Data for Registration, Evaluation, Authorisation and Restriction of Chemicals (REACH) to Regulation (EC) No 1907/2006 of the European Parliament and of the Council. 18 December 2006
- Threatened Species Scientific Committee (TSSC) (2016). Approved Conservation Advice for the Banksia Woodlands of the Swan Coastal Plain ecological community. Assessed on 24 March 2020 at
<http://www.environment.gov.au/biodiversity/threatened/communities/pubs/131-conservation-advice.pdf>
- Tun, K., Chou, L.M., Cabanban, A., Tuan, V.S., Philreefs, T., Yeemin, Suharsono, Sour, K., and Lane, D. (2004). Status of Coral Reefs, Coral Reef Monitoring and Management in Southeast Asia, 2004. pp: 235-276. In Wilkinson, C. (ed.).

- Status of coral reefs of the world: 2004. Volume 1. Australian Institute of Marine Science, Townsville, Queensland, Australia. 301 p
- UNEP/IUCN (1988). Coral Reefs of the World. Vol. 2: Indian Ocean, Red Sea and Gulf. UNEP Regional Seas Directories and Bibliographies. IUCN, Gland, Switzerland and Cambridge, UK.
- UNESCO (2013). Shark Bay, Western Australia. Accessed 7 August 2013. <http://whc.unesco.org/en/list/578>
- UNESCO (2014). Komodo National Park. Accessed 5 Feb 2014. <http://whc.unesco.org/en/list/609>
- United States Environmental Protection Agency (2014). THPS Biocides: An New Class of Antimicrobial Chemistry Viewed 13 August 2014 <http://www2.epa.gov/green-chemistry/1997-designing-greener-chemicals-award>
- V & C Semeniuk Research Group (VCSRG) (1988). The Mangroves of the Lowendal Islands and Montebello Islands. Harriet Oilfield development triennial report, October 1988, 65 pp.
- Verhejen, F.J. (1985). Photopollution: artificial light optic spatial control systems fail to cope with. Incidents, causations, remedies. *Experimental Biology*, vol. 44, pp. 1-18.
- Vieira, L.R., and Guilhermino, L. (2012). Multiple stress effects on marine planktonic organisms: Influence of temperature on the toxicity of polycyclic aromatic hydrocarbons to *Tetraselmis chuii*. *Journal of Sea Research*, 72, 94-98.
- VOGA. CGS Source Control Plan, document no. VOG- 3000-YH-0001
- VOGA. Deviation Risk Assessment Manual, document no. VOG-2000-RD-0014
- VOGA. Wandoo Emergency Response Plan, document no. VOG-2000-RD-0017
- VOGA. Fire and Safety Systems Integrity Management Manual, document no. WPA-7000-YH-1004
- VOGA. HSE MS Employee Involvement and Communications, document no. VOG-1000-RD-0009
- VOGA. Lifting Equipment Manual, document no. WPA-7000-YM-0002
- VOGA. Marine Operations Manual, document no. WNB-1000-YV-0001
- VOGA. Oil Spill Capability Review, document no. VOG-7000-RH-0009
- VOGA. Performance Standard Report, document no. VOG-1100-YG-0310
- VOGA. Platform Operations Manual, document no. VOG-7000-MN-0001
- VOGA. Risk Management Manual, document no. VOG-2000-MN-0001
- VOGA. Source Control Contingency Plan, document no. WNB-3000-PD-0007
- VOGA. SPM Marine Facility Procedures Manual, document no. WPA-7000-YV-0002
- VOGA. Structural Integrity Manual, document no. WPA-7000-YG-1005
- VOGA. Wandoo A Dropped Objects Study, document no. J9261-TN-X-108 Rev 0, January 1996
- VOGA. Wandoo A FSA Credible Fire and Explosion Analysis, document no. J9261-JV-TN-X-104, June 1996
- VOGA. Wandoo B FSA Credible Fire and Explosion Analysis, document no. J9261-JV-TN-X-003, April 1996
- VOGA. Wandoo Basis of Design, document no. WNB-7000-AG-001
- VOGA. Wandoo Field Oil Spill Contingency Plan, document no. WAN-2000-RD-0001
- VOGA. Wandoo Incident Management Manual, document no. VOG-2000-MN-0003
- VOGA. Wandoo Work Management Manual, document no. WPA-7000-YG-0021
- VOGA. Waste Management Procedure, document no. WPA-7000-YH-0009
- VOGA. Well Construction Environment Plan, document no. WPA-7000-YH-0001
- VOGA. Well Construction Standards Manual, document no. VOG-5000-MN-0001
- VOGA. Well Integrity Manual, document no. WPA-7000-YG-1009
- Volkman, J.K., Miller, G.J., Revill, A.T., and Connell, D.W. (1994). Environmental implications of offshore oil and gas development in Australia – oil spills. In: Swan, J.M., Neff, J.M. and Young, P.C. (eds). Environmental implications of offshore oil and gas development in Australia: The findings of an independent scientific review. Australian Petroleum Exploration Association, Sydney.
- Walker, D.I., and McComb, A.J. (1990). Salinity response of the seagrass *Amphibolus Antarctica*: an experimental validation of field results. *Aquatic Botany* 36:359-366.
- Walker, D.I., and Prince, R.I.T. (1987). Distribution and biogeography of seagrass species on the northwest coast of Australia. *Aquatic Botany* 29: 19-32.
- Walraven, E. (1992). Rescue and Rehabilitation of Oiled Birds Zoological Parks Board of New South Wales. Taronga Zoo, Sydney.
- Walthall, W.K., and Stark, J.D. (1999). The acute and chronic toxicity of two xanthene dyes, fluorescein sodium salt and Phloxine B, to *Daphnia pulex* (Leydig). *Environ. Pollut.* **104**: pp 207-2155

- Ward, T.J., and Rainer, S.F. (1988). Decapod crustaceans of the North West Shelf, a tropical continental shelf of north-western Australia, Australian Journal of Marine and Freshwater Research, 39, 751-765.
- Wardrup, J.A. (1987). The effects of oils and dispersants on mangroves: a review and bibliography. Occasional paper no. 2. Environmental Studies, University of Adelaide, South Australia, (70 pp).
- Watson, W.T.A., Joseph, L.N., and Watson, J.E.M. (2009). A rapid assessment of the impacts of the Montara oil leak on birds, cetaceans and marine Reptiles, Prepared on behalf of the Department of the Environment, Water, heritage and the Arts, Queensland.
- Weather Online (2014). Indonesia. Accessed 6 Feb 2014, <http://www.weatheronline.co.uk/reports/climate/Indonesia.htm>
- Webb, C.L.F., and Kempf, N.J. (1998). The impact of shallow water seismic in sensitive areas. Society of Petroleum Engineers Technical Paper, SPE 46722
- Webb, G.J.W., P.J. Whitehead & S.C. Manolis (1987). Crocodile management in the Northern Territory of Australia. In: Webb, G. J. W., S. C. Manolis & P. J. Whitehead, eds. Wildlife Management: Crocodiles and Alligators. Page(s) 107-124. Sydney, Surrey Beatty & Sons.
- Webb, G.J.W., R. Buckworth & S.C. Manolis (1983). *Crocodylus johnstoni* in the McKinlay River Area, N.T. III Growth, movement and the population age structure. Australian Wildlife Research. 10:383-401.
- Webb, G.J.W., Messel, H., and Magnusson, W. (1977). The nesting of *Crocodylus porosus* in Arnhem Land, Northern Australia. *Copeia* 2: 238-249.
- Wells, F.E., Walker, D.I., and Jones, D.S. 2003. The marine flora and fauna of Dampier, Western Australia. Western Australian Museum, Perth.
- Wells, F.E., McDonald, J.I., and Huisman, J.M. (2009). Introduced marine species in Western Australia. Published by the Department of Fisheries, Perth, WA.
- Wells, F.E., Walker, D.I., and Jones, D.S. (2003). The marine flora and fauna of Dampier, Western Australia. Western Australian Museum, Perth.
- Whiting, S.D., Long, J.L., Hadden, K., and Lauder, A. (2007). Insights into size, seasonality and biology of a nesting population of the Olive Ridley turtle in northern Australia. *Wildlife Research* 34: 200-210.
- Whitten, T., Soeriaatmadja R.E., and Afif, S.A. (1996). Ecology of Java and Bali. Periplus Editions (HK) Ltd., Republic of Singapore
- Wiese, F.K., Montevecchi, W.A., Davoren, G.K., Huettmann, F., Diamond, A.W., and Linke, J. (2001). Seabirds at Risk around Offshore Oil Platforms in the North-west Atlantic. Wilson, K., and Ralph, P. 2008. Effects of Oil and Dispersed oil on Temperate Seagrass: Scaling of Pollution Impacts, Plant Functional Biology and Climate Change Cluster, Sydney.
- Williams, T.D., and Brown, B.R.H. (1992). The acute and chronic toxicity of ammonia to the marine copepod *Tisbe battagliai*. ICI Group Experimental Laboratory, Brixham. Report No. BL440/B.
- Wilson, K., and Ralph, P. (2008). Effects of Oil and Dispersed oil on Temperate Seagrass: Scaling of Pollution Impacts, Plant Functional Biology and Climate Change Cluster, Sydney.
- Wilson, R.D., Monaghan, P.H., Osanik, A., Price, L.C., and Rogers, M.A. (1973). Estimate of annual input of petroleum to the marine environment from natural marine seepage. Transactions - Gulf Coast Association of Geological Societies 23:182-193.
- Wilson, S., Polovina, J., Stewart, B., and Meekan, M. (2006). Movements of whale sharks (*Rhincodon typus*) tagged at Ningaloo Reef. Marine Biology, vol. 147, pg. 1157-1166.
- Witzell, W.N. (1983). Synopsis of biological data on the hawksbill turtle *Eretmochelys imbricata* (Linnaeus, 1766). *FAO Fisheries Synopsis* 137: 1-78.
- Wolanski, E. (1994). Physical oceanographic processes of the Great Barrier Reef. CRC Press. Boca Raton.
- Woodhams, J., Viera, S., and Stobuzki, I. (eds). (2012). Fishery Status Reports 2011, Australian Bureau of Agriculture and Resource Economics and Sciences, Canberra.
- Woodroffe, C.D. (2009). Relict Mangrove Stand on Last Interglacial Terrace, Christmas Island, Indian Ocean. Northern Australia Research Unit, Australian National University, Darwin NT, Australia.
- Woodside (2009). Scott Reef status report 2008, Woodside, Perth.
- Woodside Energy (2006). Pluto LNG Project Public Environmental Review. Woodside Energy Limited, Perth, Western Australia.
- Wright, D.A., and Welbourn, P. (2002). Environmental Toxicology. Cambridge University Press, Cambridge, U.K.

- Zhang, Y., Chen, D., Ennis, A.C., Polli, J.R., Xiao, P., Zhang, B., Stellwag, E.J., Overton, A., and Pan, X. (2013). Chemical dispersant potentiates crude oil impacts on growth, reproduction, and gene expression in *Caenorhabditis elegans*. *Archives of Toxicology* Vol. 87:371–382.
- Zhu, S., Codi King, S., Haasch, M.L. (2008). Biomarker induction in tropical fish species on the Northwest Shelf of Australia by produced formation water *Marine Environmental Research*, Volume 65 (4): 315-324.

VERMILION OIL & GAS AUSTRALIA

Title: Wandoo Facility Environment Plan
Number: WPA-7000-YH-0007
Revision: 16
Date: 21 April 2021



APPENDICES

Appendix 1: Compliance with Divisions 2.2A and 2.3 of the OPGGS(E)R



APPENDIX 1

Compliance with Divisions 2.2A and 2.3 of the OPGGS(E)R

OPGGS(E) Regulations	Regulation	Description	Relevant Section of EP
Division 2.2A: Reg 11A(1)	In the course of preparing the EP, or a revision of an EP, the titleholder of an activity must consult each of the following (a relevant person): <ul style="list-style-type: none"> a) each Department or agency of the Commonwealth to which the activities to be carried out under the EP, or the revision of the EP, may be relevant; b) each Department or agency of a State or the Northern Territory to which the activities to be carried out under the EP, or the revision of the EP, may be relevant; c) the Department of the responsible State Minister, or the responsible Northern Territory Minister; d) a person or organisation whose functions, interests or activities may be affected by the activities to be carried out under the EP, or the revision of the EP; and e) any other person or organisation that the titleholder considers relevant. 	<p>Relevant sections contain details of the:</p> <ul style="list-style-type: none"> • methodology of identifying stakeholders; • process for assessing stakeholders; • results of the stakeholder classification; • stakeholder consultation summary, detailing communication with all relevant stakeholders; and • summary of the consultation program undertaken by VOGA including pre-submission ongoing consultation. 	Section 9: Stakeholder consultation
Division 2.2A: Reg 11A(2)	For the purpose of the consultation, the titleholder must give each relevant person sufficient information to allow the relevant person to make an informed assessment of the possible consequences of the activity on the functions, interests or activities of the relevant person.		
Division 2.2A: Reg 11A(3)	The titleholder must allow a relevant person a reasonable period for the consultation.		
Division 2.2A: Reg 11A(4)	The titleholder must tell each relevant person the titleholder consults that: <ul style="list-style-type: none"> (a) the relevant person may request that particular information the relevant person provides in the consultation not be published; and (b) information subject to such a request is not to be published under this Part. 		
Division 2.3: Reg 14(9)	The implementation strategy must provide for appropriate consultation with: <ul style="list-style-type: none"> a) relevant authorities of the Commonwealth, a State or Territory; and b) other relevant interested persons or organisations. 		
Division 2.3: Reg 13(1)	The EP must contain a comprehensive description of the activity including the following: <ul style="list-style-type: none"> a) the location or locations of the activity; b) general details of the construction and layout of any facility; c) an outline of the operational details of the activity (for example, seismic surveys, exploration drilling or production) and proposed timetables; d) any additional information relevant to consideration of environmental impacts and risks of the activity. 		

OPGGS(E) Regulations	Regulation	Description	Relevant Section of EP
Division 2.3: Reg 13(2)	The EP must: a) describe the existing environment that may be affected by the activity; and b) include details of the particular relevant values and sensitivities (if any) of that environment.	A detailed environmental description is provided including the natural, cultural, socio-economic environments and consideration of values and sensitivities in the areas that may be affected by the activity.	Section 4: Description of the environment
Division 2.3: Reg 13(3)	Without limiting paragraph (2)(b), particular relevant values and sensitivities may include any of the following: a) the world heritage values of a declared World Heritage property within the meaning of the EPBC Act; b) the national heritage values of a National Heritage place within the meaning of that Act; c) the ecological character of a declared Ramsar wetland within the meaning of that Act; d) the presence of a listed threatened species or listed threatened ecological community within the meaning of that Act; e) the presence of a listed migratory species within the meaning of that Act; f) any values and sensitivities that exist in, or in relation to, part or all of: (i) a Commonwealth marine area within the meaning of that Act; or (ii) Commonwealth land within the meaning of that Act.		
Division 2.3: Reg 13(4)	The EP must: a) describe the requirements, including legislative requirements, that apply to the activity and are relevant to the environmental management of the activity; and b) demonstrate how those requirements will be met.	Details of applicable legislative requirements are provided. Means for achieving compliance with these requirements are detailed in relation to each identified activity and associated environmental risk.	Section 1.6: Applicable legislation and code Section 6: Hazard assessment
Division 2.3: Reg 13(5)	The EP must include: a) details of the environmental impacts and risks for the activity; b) an evaluation of all the impacts and risks, appropriate to the nature and scale of each impact or risk; and c) details of the control measures that will be used to reduce the impacts and risks of the activity to as low as reasonably practicable and an acceptable level.	The sources of impacts and risks are identified, described and evaluated.	Section 5: Risk assessment methodology Section 6: Hazard assessment
Division 2.3: Reg 13(6)	To avoid doubt, the evaluation mentioned in paragraph (5)(b) must evaluate all the environmental impacts and risks arising directly or indirectly from: a) all operations of the activity; and b) potential emergency conditions, whether resulting from accident or any other reason.	A detailed assessment of each identified risk and impact.	Section 6: Hazard assessment

OPGGS(E) Regulations	Regulation	Description	Relevant Section of EP
Division 2.3: Reg 13(7)	The EP must: a) set environmental performance standards for the control measures identified under paragraph (5)(c); and b) set out the environmental performance outcomes against which the performance of the titleholder in protecting the environment is to be measured; and c) include measurement criteria that the titleholder will use to determine whether each environmental performance outcome and environmental performance standard is being met.	Based on the risk assessment, details of the: <ul style="list-style-type: none"> performance outcomes; performance standards (including design features and operational controls which will be applied); and measurement criteria that will be used, are provided for each risk element.	Section 6: Hazard assessment
Division 2.3: Reg 14(1)	The EP must contain an implementation strategy for the activity in accordance with this regulation.	Elements of the implementation strategy in relation to specific risks are provided.	Section 7: Implementation strategy Section 8: Reporting
Division 2.3: Reg 14(2)	The implementation strategy must: a) state when the titleholder will report to the Regulator in relation to the titleholder's environmental performance for the activity; and b) provide that the interval between reports will not be more than 1 year.	External routine reporting requirements are provided.	Section 8.1: Routine reports
Division 2.3: Reg 14(3)	The implementation strategy must contain a description of the environmental management system for the activity, including specific measures to be used to ensure that, for the duration of the activity: a) the environmental impacts and risks of the activity continue to be identified and reduced to a level that is ALARP; and b) control measures detailed in the EP are effective in reducing the environmental impacts and risks of the activity to ALARP and an acceptable level; and c) environmental performance outcomes and standards set out in the EP are being met.	Implementation strategy and process is described to demonstrate that performance standards are monitored to ensure that risks are managed to ALARP and an acceptable level for the activity.	Section 7: Implementation strategy
Division 2.3: Reg 14(4)	The implementation strategy must establish a clear chain of command, setting out the roles and responsibilities of personnel in relation to the implementation, management and review of the EP, including during emergencies or potential emergencies.	The key roles and responsibilities of personnel in delivering the implementation strategy are provided.	Section 7.4: Key roles and responsibilities
Division 2.3: Reg 14(5)	The implementation strategy must include measures to ensure that each employee or contractor working on, or in connection with, the activity is aware of his or her responsibilities in relation to the EP, including during emergencies or potential emergencies, and has the appropriate competencies and training.	Details of contractor and staff awareness of environmental responsibilities.	Section 7.3: Contractor management Section 7.5 Training and competency



APPENDIX 1

Compliance with Divisions 2.2A and 2.3 of the OPGGS(E)R

OPGGS(E) Regulations	Regulation	Description	Relevant Section of EP
Division 2.3: Reg 14(6)	The implementation strategy must provide for sufficient monitoring, recording, audit, management of non-conformance and review of the titleholder's environmental performance and the implementation strategy to ensure that the environmental performance outcomes and standards in the EP are being met.	Implementation strategy and process is described to demonstrate that performance standards are monitored to ensure that risks are managed to ALARP for the activity. A monitoring and reporting overview is described, both external and internal reporting procedures, monitoring and auditing of VOGA's performance.	Section 7: Implementation strategy Section 8: Reporting
Division 2.3: Reg 14(7)	The implementation strategy must provide for sufficient monitoring of, and maintaining a quantitative record of, emissions and discharges (whether occurring during normal operations or otherwise), such that the record can be used to assess whether the environmental performance outcomes and standards in the EP are being met.	Method of recording emissions and discharges is provided.	Section 8.1: Routine reports
Division 2.3: Reg 14(8)	The implementation strategy must contain an oil pollution emergency plan and provide for the updating of the plan.	Emergency response, including oil spill contingency planning is provided.	Wandoo Field OSCP [WAN-2000-RD-0001] Section 7.10: Oil Pollution Response
Division 2.3: Reg 14(8AA) to Reg 14(8E)	The oil pollution emergency plan must include adequate arrangements for responding to and monitoring oil pollution, and testing response arrangements.	Details contained within the Wandoo Field OSCP [WAN-2000-RD-0001].	Wandoo Field OSCP [WAN-2000-RD-0001] Section 7.10 Oil Pollution Response
Division 2.3: Reg 14(10)	The implementation strategy must comply with the Act, the regulations and any other environmental legislation applying to the activity.	Environmental legislation framework applicable to the implementation strategy.	Section 1.6: Applicable legislation and code Section 7: Implementation strategy
Division 2.3: Reg 15(1)	The EP must include the following details for the titleholder: a) name; b) business address; c) telephone number (if any); d) fax number (if any); e) email address (if any); and f) if the titleholder is a body corporate that has an ACN (within the meaning of the <i>Corporations Act 2001</i>)—ACN.	Titleholder details provided.	Section 1.3: The proponent



APPENDIX 1

Compliance with Divisions 2.2A and 2.3 of the OPGGS(E)R

OPGGS(E) Regulations	Regulation	Description	Relevant Section of EP
Division 2.3: Reg 15(2)	The EP must also include the following details for the titleholder's nominated liaison person: a) name; b) business address; c) telephone number (if any); d) fax number (if any); and e) email address (if any).	Titleholder liaison details provided.	Section 1.3: The proponent
Division 2.3: Reg 15(3)	The EP must include arrangements for notifying the Regulator of a change in the titleholder, a change in the titleholder's nominated liaison person or a change in the contact details for either the titleholder or the liaison person.	Arrangements for changing titleholder details or nominated liaison person provided.	Section 8.1: Routine reports
Division 2.3: Reg 15(1)	The EP must include arrangements for: a) Recording, monitoring and reporting information about the activity (including information required to be recorded under the Act, the regulations and any other environmental legislation applying to the activity) sufficient to enable the Regulator to determine whether the environmental performance outcomes and standards in the EP are met; and b) Reporting to the Regulator at intervals agreed with the Regulator, but not less often than annually.	Definition of and processes for reporting requirements are defined. This includes routine reporting as well as reportable and recordable incidents as required by the Regulations.	Section 8: Reporting
Division 2.3: Reg 16(a)	The EP must contain a statement of the titleholder's corporate environmental policy.	A copy of VOGA's Health Safety and Environment Policy is included, and details of its implementation are described in Section 7.	Section 1.5: Corporate environmental performance philosophy Appendix 2: HSE Policy
Division 2.3: Reg 16(b)	The EP must contain a report on all consultations under regulation 11A of any relevant person by the titleholder, that contains: (i) a summary of each response made by a relevant person; and (ii) an assessment of the merits of any objection or claim about the adverse impact of each activity to which the environment plan relates; and (iii) a statement of the titleholder's response, or proposed response, if any, to each objection or claim; and (iv) a copy of the full text of any response by a relevant person		Section 9: Stakeholder Consultation Sensitive Information Document (Sseparate to EP)
Division 2.3: Reg 16(c)	The EP must contain details of all reportable incidents in relation to the proposed activity.	Incident reporting definition and process is provided which includes reportable incidents.	Section 8.3.1: Reportable incidents
Division 2.3: Reg 26	Notifying reportable incidents, reporting recordable incidents and reporting environmental performance.	All reportable and recordable incident arrangements provided.	Section 8: Reporting

Appendix 2: VOGA Health, Safety and Environment (HSE) Policy

HEALTH, SAFETY AND ENVIRONMENT (HSE) POLICY

VERMILION IS COMMITTED TO ENSURING WE CONDUCT OUR ACTIVITIES IN A MANNER THAT WILL PROTECT THE HEALTH AND SAFETY OF ITS EMPLOYEES, CONTRACTORS AND THE PUBLIC. OUR HSE VISION IS TO FULLY INTEGRATE HEALTH, SAFETY AND ENVIRONMENT INTO OUR BUSINESS, WHERE OUR CULTURE IS RECOGNIZED AS A MODEL BY INDUSTRY AND STAKEHOLDERS, RESULTING IN A HEALTHY WORKPLACE FREE OF INCIDENTS.

VERMILION WILL MAINTAIN HEALTH, SAFETY AND ENVIRONMENTAL PRACTICES AND PROCEDURES THAT COMPLY WITH OR EXCEED REGULATORY REQUIREMENTS AND INDUSTRY STANDARDS. VERMILION'S HSE ACTIONS WILL REINFORCE OUR CORPORATE CORE VALUES OF EXCELLENCE, TRUST, RESPECT, AND RESPONSIBILITY. VERMILION ENERGY WILL:

- MAINTAIN A STRONG, INTEGRATED HEALTH, SAFETY AND ENVIRONMENTAL MANAGEMENT SYSTEM TO IDENTIFY AND MANAGE RISKS;
- ACCEPT RESPONSIBILITY AND ACCOUNTABILITY FOR PROVIDING LEADERSHIP, VISIBLE COMMITMENT AND DIRECTION TO MEET OUR HSE PERFORMANCE TARGETS;
- CONTINUOUSLY EVALUATE AND IMPROVE POLICIES AND OPERATING PRACTICES;
- INTEGRATE HSE INTO BUSINESS OBJECTIVES;
- PROVIDE EVERY EMPLOYEE AND CONTRACTOR WITH A SAFE AND HEALTHY WORKPLACE;
- MAKE A POSITIVE CONTRIBUTION TO THE PROTECTION OF THE ENVIRONMENT AND SEEK IMPROVEMENTS IN THE EFFICIENT USE OF NATURAL RESOURCES;
- RESPOND PROMPTLY, RESPONSIBLY AND EFFECTIVELY TO EMERGENCIES;
- FOCUS ON CONTINUAL IMPROVEMENT OF HSE PERFORMANCE;
- ENSURE OPEN AND TIMELY HSE COMMUNICATION WITH ALL STAKEHOLDERS;
- ENSURE THE RESOURCES NECESSARY TO SUPPORT THIS POLICY ARE PROVIDED.

HAZARD AWARENESS, INCIDENT PREVENTION AND ENVIRONMENTAL AWARENESS COMPRISE AN INTEGRAL PART OF ANY JOB. IT IS A JOINT EFFORT THAT REQUIRES CONTINUOUS SUPPORT OF EVERYONE WHO WORKS AT VERMILION ENERGY. THE PROTECTION OF HEALTH, SAFETY AND THE ENVIRONMENT MUST BE A KEY PART OF THE PLANNING AND EXECUTION OF EVERY TASK. ALL THOSE ENGAGED IN WORK FOR VERMILION ENERGY SHALL BE AWARE OF THIS POLICY AND ITS CONTENTS, AND SHALL COMMIT THEMSELVES TO ITS IMPLEMENTATION.



CURTIS HICKS
PRESIDENT



DARCY KERWIN
VICE PRESIDENT,
INTERNATIONAL & HSE

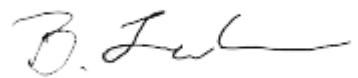

BRUCE LAKE
MANAGING DIRECTOR



Appendix 3: Oil Spill Characteristics and Trajectory Modelling

1 OVERVIEW

1.1 Modelling parameters

Table 1-1 Modelling parameters

Input Parameters	Scenario 1	Scenario 2
Scenario description	Surface well blowout	Subsea loss of CGS containment
Number of randomly selected spill start times per season	100 (300 total) for each of the unmitigated and mitigated cases	100 (300 total)
Hydrocarbon type	Wandoo crude	
Total volume released (m ³) [bbl]	4,364 [31,692]	39,750 [250,000]
Release duration	10 days after the incident starts for 68 days	24 hours
Simulation length (days)	98 days	80 days
Seasons assessed	Summer (October to February) Transitional period (March and August to September) Winter (April to July)	
Reporting surface oil exposure thresholds (g/m ²)	1 (low exposure) 10 (moderate exposure) 25 (high exposure)	
Reporting shoreline contact thresholds (g/m ²)	10 (low contact) 100 (moderate contact) 1,000 (high contact)	
Instantaneous entrained hydrocarbon exposure thresholds (ppb)	10 (low exposure) 100 (high exposure)	
Instantaneous dissolved hydrocarbon exposure threshold (ppb)	6 (low exposure) 50 (moderate exposure) 400 (high exposure)	

1.2 Sea-surface, Shoreline and In-Water Thresholds

The thresholds described below for surface, shoreline, and in-water (entrained and dissolved) oil have been adopted according to low, moderate and high, based on increasing concentrations of oiling:

Low thresholds are unlikely to affect species but would be visible and detectable by instrumentation and may trigger socioeconomic impacts, such as temporary closures of areas such as fishing grounds as a precautionary measure.

Moderate thresholds represent moderate concentrations of oil exposure/contact which are anticipated to result in behavioural changes and sub-lethal effects to biota (effects that may result in changes in reproduction or growth) and are unlikely to result in lethal effects (representing potential death of individuals) although lethality may occur if ingestion occurs.

High thresholds represent high concentrations of oil that are expected to result in sub-lethal and lethal effects to at least some species (representing potential death of individuals).

Reporting threshold values (based on the scientific literature) represent potential effects ranging from possible social and economic effects, degradation of water quality as well as possible effects on the behaviour, survival and recruitment success on biota. The changes in the state of the oil over

time, in addition to a wide range of sensitivities and in turn potential effects on marine life, does not make it possible to strictly assign single specific effect thresholds. Instead, the analysis presented herein is presented for ranges of low, moderate and high threshold levels, with separate analysis for oil floating at the sea surface, stranded on shoreline, dissolved in the water column and suspended in the water column.

Moderate levels were defined based on available evidence that indicated the potential for low-level sub-lethal effects on some biota, or else evidence of reduced survival rates of sensitive species. This level can be considered a lower ecological threshold. The higher threshold was defined on the assumption that there would be more potential for reduced survivorship of less sensitive species.

1.2.1 Sea-surface Exposure Thresholds

As a conservative approach, the same reporting thresholds for fresh and weathered oil exposure on the sea surface were applied in this study, which were 1-10 g/m² (low), 10-25 g/m² (moderate) and above 25 g/m² (high) (Table 1-2). As the effects of fresh oil are better understood than for weathered oil, appropriate effects thresholds for fresh oil are more readily identifiable. Exposure pathways of species to weathered oil (i.e. smothering and potential ingestion for some species) are less likely to result in adverse effects.

Table 1-2 Oil exposure thresholds on the sea surface.

Potential level of exposure	Trigger value (g/m ²)
Low	1- 10
Moderate	10* - 25
High	> 25

* 10 g/m² also used to define the threshold for actionable sea surface oil.

The lowest threshold to better assess the potential for sea surface exposure, was 1 g/m², which equates approximately to an average thickness of 1 µm, referred to as visible oil. Oil of this thickness is described as rainbow sheen in appearance, according to the Bonn Agreement Oil Appearance Code (Bonn Agreement 2009) (see Table 1-3). This threshold is considered below levels which would cause environmental harm and it is more indicative of the areas perceived to be affected due to its visibility on the sea surface and potential to trigger temporary closures of areas (i.e. fishing grounds) as a precautionary measure. Table 1-3 provides a description of the appearance in relation to exposure zone thresholds used to classify the zones of sea surface exposure.

Ecological impact has been estimated to occur at 10 g/m² (a film thickness of approximately 10 µm or 0.01 mm) according to French et al. (1996) and French-McCay (2009) as this level of fresh oiling has been observed to mortally impact some birds through adhesion of oil to their feathers, exposing them to secondary effects such as hypothermia. The appearance of oil at this average thickness has been described as a metallic sheen (Bonn Agreement, 2009). Concentrations above 10 g/m² is also considered the lower actionable threshold, where oil may be thick enough for containment and recovery as well as dispersant treatment (AMSA, 2015).

Scholten et al. (1996) and Koops et al. (2004) indicated that oil concentrations on the sea surface of 25 g/m² (or greater), would be harmful for all birds that have landed in an oil film due to potential contamination of their feathers, with secondary effects such as loss of temperature regulation and ingestion of oil through preening. The appearance of oil at this thickness is also described as metallic

sheen (Bonn Agreement, 2009). Note that the higher threshold applied in this study falls below the thickness that would begin to present as patches of true oil colour.

Figure 1-1 shows examples of the differences between oil colour and corresponding thickness on the sea surface. Hydrocarbons in the marine environment may appear differently due the ambient environmental conditions (wind and wave action).

Table 1-3 The Bonn Agreement Oil Appearance Code.

Code	Description/Appearance	Layer Thickness Interval (g/m² or μm)	Litres per km²
1	Sheen (silvery/grey)	0.04 – 0.30	40 – 300
2	Rainbow	0.30 – 5.0	300 – 5,000
3	Metallic	5.0 – 50	5,000 – 50,000
4	Discontinuous True Oil Colour	50 – 200	50,000 – 200,000
5	Continuous True Oil Colour	≥ 200	≥ 200,000

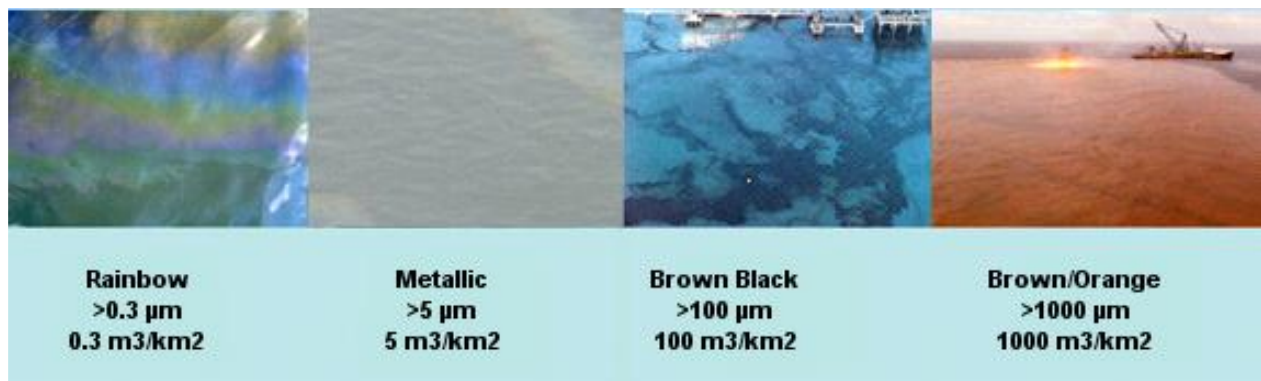

Figure 1-1 Photographs showing the difference between oil colour and thickness on the sea surface (source: adapted from Oil Spill Solutions.org, 2015).

The generic oil colour categories used in this report are meant as a guide only. For more accurate description of oil appearance on the sea surface a detailed analysis of an oil should be undertaken.

The specific oil type will determine appearance (i.e. colour) and behaviour on the sea surface. Lighter oils such as condensates, have true oil colours that are pale or transparent. As such, these oil types may not increase beyond a rainbow or metallic sheen, despite their thickness increasing beyond 25 g/m² (~25 μm). Moreover, the physical properties and appearance of oil types will change due to weathering on the sea surface. For example, oils with high paraffinic wax content will form waxy sheets that break up into flakes or nodules after the more volatile components have evaporated. Take up of water by the oil (emulsification) will also significantly change the appearance and thickness of floating oil. Stable water-in-oil emulsions will have a higher combined mass and thickness and will present as thick, semi-solid, aerated layers that tend to be coloured strongly red/brown, orange or yellow, rather than the true oil colour.

It should be noted that in the case of solidified or emulsified oils, mass per area estimates cannot be directly referenced to the Bonn Agreement visibility scale that refers only to oil present as films or slicks of oil alone.

1.2.2 Shoreline Contact Threshold

The thresholds for shoreline contact were 10-100 g/m² (low), 100-1,000 g/m² (moderate) and above 1000 g/m² (high).

The lower threshold (10 g/m²) was applied as the reporting limit for oil on shore. This threshold may trigger socio-economic impact, such as triggering temporary closures of beaches to recreation or fishing, or closure of commercial fisheries and might trigger attempts for shore clean-up on beaches or man-made features/amenities (breakwaters, jetties, marinas, etc.). In previous risk assessment studies, French-McCay et al. (2005a; 2005b) used a threshold of 10 g/m², equating to approximately two teaspoons of oil per square meter of shoreline, as a low impact threshold when assessing the potential for shoreline contact.

French et al. (1996) and French-McCay (2009) define a shoreline oil threshold of 100 g/m², or above, would potentially harm shorebirds and wildlife (furbearing aquatic mammals and marine reptiles on or along the shore) based on studies for sub-lethal and lethal impacts. This threshold has been used in previous environmental risk assessment studies (see French-McCay, 2003; French-McCay et al., 2004, French-McCay et al., 2011; 2012; NOAA, 2013). Additionally, a shoreline concentration of 100 g/m², or above, is the minimum limit that the oil can be effectively cleaned according the AMSA (2015) guideline. This threshold equates to approximately ½ a cup of oil per square meter of shoreline contacted. The appearance is described as a thin oil coat.

The higher threshold of 1,000 g/m², and above, was adopted to inform locations that might receive oil accumulation levels that could have a higher potential for ecological effect. Observations by Lin and Mendelssohn (1996), demonstrated that loadings of more than 1,000 g/m² of oil during the growing season would be required to impact marsh plants significantly. Similar thresholds have been found in studies assessing oil impacts on mangroves (Grant et al., 1993; Suprayogi and Murray, 1999). This concentration equates to approximately 1 litre or 4 ¼ cups of fresh oil per square meter of shoreline contacted. The appearance is described as an oil cover.

Table 1-4 Thresholds for oil accumulation on shorelines.

Potential level of exposure	Trigger value (g/m ²)
Low	10 - 100
Moderate	100* - 1,000
High	> 1,000

* 100 g/m² also used to define the threshold for actionable shoreline oil.

1.2.3 Dissolved and Entrained Hydrocarbon Thresholds

Oil is a mixture of thousands of hydrocarbons of varying physical, chemical, and toxicological characteristics, and therefore, demonstrate varying fates and impacts on organisms. As such, for in-water exposure, the SIMAP model provides separate outputs for dissolved and entrained hydrocarbons from oil droplets. The consequences of exposure to dissolved and entrained components will differ because they have different modes and magnitudes of effect.

Entrained hydrocarbon concentrations were calculated based on oil droplets that are suspended in the water column, though not dissolved. The composition of this oil would vary with the state of weathering (oil age) and may contain soluble hydrocarbons when the oil is fresh. Calculations for

dissolved hydrocarbons specifically calculates oil components which are dissolved in water, which are known to be the primary source of toxicity exerted by oil.

1.2.3.1 Dissolved Hydrocarbons

Laboratory studies have shown that dissolved hydrocarbons exert most of the toxic effects of oil on aquatic biota (Carls et al., 2008; Nordtug et al., 2011; Redman, 2015). The mode of action is a narcotic effect, which is positively related to the concentration of soluble hydrocarbons in the body tissues of organisms (French-McCay, 2002). Dissolved hydrocarbons are taken up by organisms directly from the water column by absorption through external surfaces and gills, as well as through the digestive tract. Thus, soluble hydrocarbons are termed “bioavailable”.

Hydrocarbon compounds vary in water-solubility and the toxicity exerted by individual compounds is inversely related to solubility, however bioavailability will be modified by the volatility of individual compounds (Nirmalakhandan & Speece, 1988; Blum & Speece, 1990; McCarty, 1986; McCarty et al., 1992a, 1992b; Mackay et al., 1992; McCarty & Mackay, 1993; Verhaar et al., 1992, 1999; Swartz et al., 1995; French-McCay, 2002; McGrath et al., 2009). Of the soluble compounds, the greatest contributor to toxicity for water-column and benthic organisms are the lower-molecular-weight aromatic compounds, which are both volatile and soluble in water. Although they are not the most water-soluble hydrocarbons within most oil types, the polynuclear aromatic hydrocarbons (PAHs) containing 2-3 aromatic ring structures typically exert the largest narcotic effects because they are semi-soluble and not highly volatile, so they persist in the environment long enough for significant accumulation to occur (Anderson et al., 1974, 1987; Neff & Anderson, 1981; Malins & Hodgins, 1981; McAuliffe, 1987; NRC, 2003). The monoaromatic hydrocarbons (MAHs), including the BTEX compounds (benzene, toluene, ethylbenzene, and xylenes), and the soluble alkanes (straight chain hydrocarbons) also contribute to toxicity, but these compounds are highly volatile, so that their contribution will be low when oil is exposed to evaporation and higher when oil is discharged at depth where volatilisation does not occur (French-McCay, 2002).

French-McCay (2002) reviewed available toxicity data, where marine biota was exposed to dissolved hydrocarbons prepared from oil mixtures, finding that 95% of species and life stages exhibited 50% population mortality (LC50) between 6 and 400 ppb total PAH concentration after 96 hrs exposure, with an average of 50 ppb. Hence, concentrations lower than 6 ppb total PAH value should be protective of 97.5% of species and life stages even with exposure periods of days (at least 96 hours). Early life-history stages of fish appear to be more sensitive than older fish stages and invertebrates.

Exceedances of 10, 50 or 400 ppb over a 1 hour timestep (see Table) was applied to indicate increasing potential for sub-lethal to lethal toxic effects (or low to high), based on NOPSEMA (2019).

1.2.3.2 Entrained Hydrocarbons

Entrained hydrocarbons consist of oil droplets that are suspended in the water column and insoluble. As such, insoluble compounds in oil cannot be absorbed from the water column by aquatic organisms, hence are not bioavailable through absorption of compounds from the water. Exposure to these compounds would require routes of uptake other than absorption of soluble compounds. The route of exposure of organisms to whole oil alone include direct contact with tissues of organisms and uptake of oil by direct consumption, with potential for biomagnification through the food chain (NRC, 2005).

The 10 ppb threshold represents the very lowest concentration and corresponds generally with the lowest trigger levels for chronic exposure for entrained hydrocarbons in the ANZECC (2000) water

quality guidelines. Due to the requirement for relatively long exposure times (> 24 hours) for these concentrations to be significant, they are likely to be more meaningful for juvenile fish, larvae and planktonic organisms that might be entrained (or otherwise moving) within the entrained plumes, or when entrained hydrocarbons adhere to organisms or trapped against a shoreline for periods of several days or more.

This exposure zone is not considered to be of significant biological impact and is therefore outside the adverse exposure zone. This exposure zone represents the area contacted by the spill. This area does not define the area of influence as it is considered that the environment will not be affected by the entrained hydrocarbon at this level.

Thresholds of 10 ppb and 100 ppb were applied over a 1 hour time exposure (Table), to cover the range of thresholds outlined in the ANZECC/ARMCANZ (2000) water quality guidelines, the incremental change for greater potential effect and is per NOPSEMA (2019).

A complicating factor that should be considered when assessing the consequence of dissolved and entrained oil distributions is that there will be some areas where both physically entrained oil droplets and dissolved hydrocarbons co-exist. Higher concentrations of each will tend to occur close to the source where sea conditions can force mixing of relatively unweathered oil into the water column, resulting in more rapid dissolution of soluble compounds.

Table 1-5 Dissolved and entrained hydrocarbon exposure values assessed over a 1-hour time step, as per NOPSEMA (2019).

Threshold level	Dissolved hydrocarbon concentration (ppb)	Entrained hydrocarbon concentrations (ppb)
Low	10	10
Moderate	50	NA
High	400	100

1.3 Dispersant Application

The application of surface dispersant for the loss of well control scenario was modelled within a 40 km by 40 km zone and a 500 m radius exclusion zone around Wandoo A, Wandoo B (study release location), a potential relief well within a 3 km of Wandoo B and Stag Platform.

The dispersant effectiveness was set at 50% based on laboratory testing. It was assumed that the dispersant will be effective on fresh, weathered and emulsified oil with a minimum thickness of 10 µm and a viscosity of up to 12,500 cP. The surface dispersant application was assumed continuous for 10 hours during daylight hours only, starting from 48 hours after the initial release until the end of the spill duration. Winds were capped at 35 knots to ensure safe operating conditions for planes, but also to allow for sufficient mixing of the chemical dispersants and oil at water surface (API et al. 2001; NOAA 2010). A dispersant to oil ratio of 1:20 was applied. Table 1.6 summarises the parameters.

Table 1-6 Aerial dispersant application parameters.

Parameter	Input
Maximum Volume (m ³ /d)	After 48 hours: 30 After 72 hours: 77
Dispersant to oil ratio	1:20 (applied on oil > 10 g/m ²)
Dispersant effectiveness (%)	50
Maximum viscosity threshold (cP)	12,500
Minimum Operational Wind Speeds (knots)	2
Maximum Operational Wind Speeds (knots)	35
Operational hours	10 (during daylight only)

1.4 Hydrocarbon Characteristics

Wandoo Crude (API 19.4) was used for this oil spill modelling study. It has a density of 937.7 g/cm³, a dynamic viscosity of 161 cP and a low pour point of -24°C, which ensures that this crude will remain in a liquid state over the annual temperature range observed on the North West Shelf. It is also low in wax content, typical of a biodegraded oil and categorised as a Group IV (or persistent) oil according to both oil classifications for AMSA (2015) and the International Tanker Owner Pollution Federation (ITOPF, 2012).

Table 1-7 Physical properties for Wandoo Crude.

Properties	Wandoo Crude
Density (kg/m ³)	0.937 (at 16 °C)
API	19.4
Dynamic viscosity (cP)	161 (at 25 °C)
Pour point (°C)	-24
Hydrocarbon property category	Group IV
Hydrocarbon property classification	Persistent

2 LONG TERM WELL BLOWOUT

2.1 Sea Surface Exposure

Table 2-1 summarises the maximum distances from the release location to oil exposure zones on the sea surface for each season, for the unmitigated (no dispersant application) and mitigated cases (dispersant application).

For the unmitigated case, the maximum distance from the release location to the low (1-10 g/m²) and moderate (10-50 g/m²) exposure thresholds was 922 km west-northwest (transitional), 186 km west-southwest (summer), respectively. In comparison, for the mitigated case the maximum distance was 341 km, respectively, for the transitional and summer results. No high exposure was predicted for any of the spill trajectories in the unmitigated or mitigated cases.

Table 2-2 to Table 2-4 summarise the potential sea surface exposure to individual receptors for each season for both the unmitigated and mitigated case. For spills commencing during summer conditions, the following receptors had recorded surface oil exposure greater than 90% for the unmitigated and mitigated cases: Montebello AMP, Northwest Shelf and Pilbara (Offshore) IMCRA, Ancient coastline at 125 m depth contour Key Ecological Feature (KEF), Continental Slope Demersal Fish Communities KEF, Glomar Shoals and WA State Waters (Table 2-2).

The following receptors had recorded surface oil exposure greater than 90% for the unmitigated and mitigated cases, for spills commencing during the transitional months: Montebello AMP, Northwest Shelf and Pilbara (offshore) IMCRAs, Ancient coastline at 125 m depth contour, Continental Slope Demersal Fish Communities and Glomar Shoals KEFs (Table 2-3).

Winter conditions resulted in a broader surface oil exposure to receptors at, or above the low threshold and the following receptors recorded probabilities greater than 90%: Gascoyne AMP and Montebello AMP, Northwest Shelf IMCRA, Pilbara (offshore) IMCRA, Ancient coastline at 125 m depth contour KEF, Continental Slope Demersal Fish Communities KEF, Exmouth Plateau KEF, Montebello Islands Marine Park (MP), Tryal Rock and WA State Waters (Table 2-4), for both the unmitigated and mitigated cases.

The use of surface dispersant did demonstrate a notable reduction of the sea surface exposure at, or above the moderate threshold, hence resulting in a lesser number of environmental receptors potentially exposed to surface hydrocarbons.



Table 2-1 Maximum distance and direction from the release location to oil exposure thresholds on the sea surface, for the unmitigated and mitigated cases. Results are based on a 4,364 m³ surface release of Wandoo crude over 68 days, commencing 10 days after the start of an incident and tracked for 98 days during all seasonal conditions

Season	Distance and direction travelled	Zones of potential sea surface exposure					
		Unmitigated			Mitigated		
		Low	Moderate	High	Low	Moderate	High
Summer	Maximum distance (km) from release location	702	186	-	404	6	-
	Direction	ENE	WSW	-	ENE	WNW	-
Transitional	Maximum distance (km) from release location	922	81	-	341	6	-
	Direction	WNW	NW	-	W	ENE	-
Winter	Maximum distance (km) from release location	617	7	-	237	7	-
	Direction	WSW	WNW	-	SW	WNW	-



Table 2-2 Summary of the potential sea surface exposure to individual receptors, for both, the unmitigated and mitigated cases. Results are based on a 4,364 m³ surface release of Wandoo crude over 68 days, commencing 10 days after the start of an incident and tracked for 98 days during summer conditions

Receptors	Unmitigated						Mitigated					
	Probability of oil exposure on the sea surface (%)			Minimum time before oil exposure on the sea surface (days)			Probability of oil exposure on the sea surface (%)			Minimum time before oil exposure on the sea surface (days)		
	Low	Mod.	High	Low	Mod.	High	Low	Mod.	High	Low	Mod.	High
AMP	Argo-Rowley Terrace	10	-	-	42.67	-	-	-	-	-	-	-
	Dampier	6	-	-	20.17	-	-	2	-	-	20.08	-
	Eighty Mile Beach	4	-	-	37.21	-	-	-	-	-	-	-
	Gascoyne	19	-	-	26.21	-	-	-	-	-	-	-
	Kimberley	1	-	-	85.29	-	-	-	-	-	-	-
	Mermaid Reef	4	-	-	61.17	-	-	-	-	-	-	-
	Montebello	44	-	-	16.04	-	-	6	-	-	17.75	-
	Ningaloo	9	-	-	46.50	-	-	-	-	-	-	-
IBRA	Cape Range	9	-	-	23.29	-	-	1	-	-	23.42	-
	Pindanland	2	-	-	54.79	-	-	-	-	-	-	-
	Roebourne	7	-	-	17.88	-	-	3	-	-	21.13	-
IMCRA	Canning	5	-	-	54.79	-	-	-	-	-	-	-
	Eighty Mile Beach	3	-	-	56.50	-	-	-	-	-	-	-
	Ningaloo	11	-	-	40.46	-	-	-	-	-	-	-
	Northwest Shelf	100	4	-	11.21	33.04	-	100	-	-	11	-
	Pilbara (nearshore)	16	-	-	15.25	-	-	5	-	-	18.5	-
KEF	Ancient coastline at 125 m depth contour	92	10	-	17.79	45.79	-	31	-	-	21.5	-
	Canyons linking the Cuvier Abyssal Plain and the Cape Range Peninsula	13	-	-	42.33	-	-	-	-	-	-	-



Receptors	Unmitigated						Mitigated					
	Probability of oil exposure on the sea surface (%)			Minimum time before oil exposure on the sea surface (days)			Probability of oil exposure on the sea surface (%)			Minimum time before oil exposure on the sea surface (days)		
	Low	Mod.	High	Low	Mod.	High	Low	Mod.	High	Low	Mod.	High
	Commonwealth waters adjacent to Ningaloo Reef	9	-	-	46.50	-	-	-	-	-	-	-
	Continental Slope Demersal Fish Communities	40	-	-	22.21	-	-	4	-	-	63.75	-
	Exmouth Plateau	12	-	-	42.75	-	-	-	-	-	-	-
	Glomar Shoals	58	3	-	16.17	74.79	-	11	-	-	19.71	-
	Mermaid Reef and Commonwealth waters surrounding Rowley Shoals	7	-	-	55.92	-	-	-	-	-	-	-
MMA	Barrow Island	21	-	-	18.75	-	-	4	-	-	19.13	-
	Muiron Islands	1	-	-	69.00	-	-	-	-	-	-	-
MP	Barrow Island	1	-	-	39.92	-	-	-	-	-	-	-
	Eighty Mile Beach	1	-	-	64.00	-	-	-	-	-	-	-
	Montebello Islands	14	-	-	20.92	-	-	4	-	-	22.00	-
	Ningaloo	6	-	-	36.54	-	-	-	-	-	-	-
	Rowley Shoals	4	-	-	61.71	-	-	-	-	-	-	-
RAMSAR	Eighty-mile Beach	2	-	-	54.79	-	-	-	-	-	-	-
	Glomar Shoal	13	-	-	22.29	-	-	5	-	-	56.79	-
	Imperieuse Reef	4	-	-	61.96	-	-	-	-	-	-	-
RSB	Mermaid Reef	4	-	-	61.17	-	-	-	-	-	-	-
	Montebello Shoals	11	-	-	24.04	-	-	1	-	-	24.17	-
	Rankin Bank	14	-	-	25.71	-	-	-	-	-	-	-
	Tryal Rocks	4	-	-	40.25	-	-	-	-	-	-	-



APPENDIX 3

Oil Spill Trajectory Modelling

Receptors		Unmitigated						Mitigated					
		Probability of oil exposure on the sea surface (%)			Minimum time before oil exposure on the sea surface (days)			Probability of oil exposure on the sea surface (%)			Minimum time before oil exposure on the sea surface (days)		
		Low	Mod.	High	Low	Mod.	High	Low	Mod.	High	Low	Mod.	High
State Waters	Western Australia State Waters	47	-	-	15.38	-	-	13	-	-	19.13	-	-



Receptors	Unmitigated							Mitigated					
	Probability of oil exposure on the sea surface (%)			Minimum time before oil exposure on the sea surface (days)				Probability of oil exposure on the sea surface (%)			Minimum time before oil exposure on the sea surface (days)		
	Low	Mod.	High	Low	Mod.	High	Low	Mod.	High	Low	Mod.	High	
Rankin Bank	10	-	-	20.67	-	-	-	-	-	-	-	-	-
Rosily Shoals	1	-	-	45.08	-	-	-	-	-	-	-	-	-
State Waters Western Australia	26	-	-	21.83	-	-	7	-	-	16.25	-	-	-



Table 2-4 Summary of the potential sea surface exposure to individual receptors, for both, the unmitigated and mitigated cases. Results are based on a 4,364 m³ surface release of Wandoo crude over 68 days, commencing 10 days after the start of an incident and tracked for 98 days during winter conditions

Receptors		Unmitigated						Mitigated					
		Probability of oil exposure on the sea surface (%)			Minimum time before oil exposure on the sea surface (days)			Probability of oil exposure on the sea surface (%)			Minimum time before oil exposure on the sea surface (days)		
		Low	Mod.	High	Low	Mod.	High	Low	Mod.	High	Low	Mod.	High
AMP	Argo-Rowley Terrace	4	-	-	36.88	-	-	-	-	-	-	-	-
	Gascoyne	4	-	-	24.71	-	-	-	-	-	-	-	-
	Montebello	64	-	-	15.67	-	-	27	-	-	15.79	-	-
	Ningaloo	2	-	-	27.33	-	-	-	-	-	-	-	-
IBRA	Cape Range	3	-	-	19.79	-	-	-	-	-	-	-	-
IMCRA	Ningaloo	2	-	-	27.08	-	-	-	-	-	-	-	-
	Northwest Shelf	100	-	-	10.96	-	-	100	-	-	10.96	-	-
KEF	Ancient coastline at 125 m depth contour	85	-	-	18.00	-	-	20	-	-	18.92	-	-
	Canyons linking the Cuvier Abyssal Plain and the Cape Range Peninsula	2	-	-	29.29	-	-	-	-	-	-	-	-
	Commonwealth waters adjacent to Ningaloo Reef	2	-	-	27.33	-	-	-	-	-	-	-	-
	Continental Slope Demersal Fish Communities	46	-	-	20.58	-	-	7	-	-	19.71	-	-
	Exmouth Plateau	4	-	-	25.88	-	-	-	-	-	-	-	-
	Glomar Shoals	68	-	-	16.46	-	-	17	-	-	17.92	-	-
MMA	Muiron Islands	2	-	-	25.42	-	-	-	-	-	-	-	-
MP	Montebello Islands	5	-	-	19.42	-	-	1	-	-	21.25	-	-
	Ningaloo	1	-	-	28.17	-	-	-	-	-	-	-	-
RSB	Glomar Shoal	14	-	-	20.21	-	-	1	-	-	20.67	-	-



APPENDIX 3

Oil Spill Trajectory Modelling

Receptors		Unmitigated						Mitigated						
		Probability of oil exposure on the sea surface (%)			Minimum time before oil exposure on the sea surface (days)			Probability of oil exposure on the sea surface (%)			Minimum time before oil exposure on the sea surface (days)			
		Low	Mod.	High	Low	Mod.	High	Low	Mod.	High	Low	Mod.	High	
	Rankin Bank	2	-	-	39.29	-	-	-	-	-	-	-	-	-
State Waters	Western Australia	7	-	-	19.33	-	-	5	-	-	19.29	-	-	

2.2 Shoreline Exposure

Table 2-5 presents a summary of the predicted shoreline contact for the unmitigated and mitigated cases. For the unmitigated case, the probability of contact to any shoreline at, or above, the low threshold (10 g/m^2) during the summer, transitional and winter seasons was 62%, 33% and 11%, respectively. By applying dispersant, the probability reduced to 24%, 15% and 6%, respectively.

The minimum time before shoreline contact was approximately 14.21 days, 23.17 days and 19.38 days for the summer, transitional and winter seasons, respectively, while after implementing the mitigation option, the earliest shoreline contact was 16.54 days, 18 days and 17.75 days, respectively.

The greatest volume of oil predicted to come ashore from an unmitigated spill trajectory was 303 m^3 and reduced to 52 m^3 when surface dispersant was applied, an 82% reduction. While, the maximum length of shoreline contact at or above the moderate threshold (or actionable threshold of 100 g/m^2) was 53 km, this distance reduced to 15 km by applying surface dispersant.

Table 2-5 Summary of oil contact to any shorelines for the unmitigated and mitigated cases. Results are based on a $4,364 \text{ m}^3$ surface release of Wandoo crude over 68 days, commencing 10 days after the start of an incident and tracked for 98 days during all seasonal conditions.

Shoreline Statistics	Unmitigated			Mitigated		
	Summer	Transitional	Winter	Summer	Transitional	Winter
Probability of contact to any shoreline at, or above 10 g/m^2 (%)	62	33	11	24	15	6
Absolute minimum time before shoreline contact at, or above 10 g/m^2 (days)	14.21	23.17	19.38	16.54	18.00	17.75
Maximum volume of oil ashore (m^3)	303	72	37	52	22	11
Average volume of oil ashore (m^3)	81	17	9	12	5	6
Maximum length of shoreline contact at or above 10 g/m^2 (km)	71	28	17	20	7	9
Average length of shoreline contact at or above 10 g/m^2 (km)	18	8	4	5	2	4
Maximum length of shoreline contact at or above 100 g/m^2 (km)	53	15	13	15	6	5
Average length of shoreline contact at or above 100 g/m^2 (km)	15	7	7	4	3	3
Maximum length of shoreline contact at or above $1,000 \text{ g/m}^2$ (km)	9	2	-	1	-	-
Average length of shoreline contact at or above $1,000 \text{ g/m}^2$ (km)	3	1	-	1	-	-

Under summer conditions, the highest probabilities of shoreline contact at the low threshold were predicted at Montebello Islands (22% - unmitigated; 11% - mitigated), Broome (22%; unmitigated; 5% - mitigated), Legendre Island (15% - unmitigated; 3% - mitigated) and Barrow Island (15% - unmitigated; no contact – mitigated), while the earliest shoreline contact was recorded on Cohen Island (14.21 days – unmitigated; 17 days – mitigated).

For spills commencing during transitional months, the greatest probabilities of shoreline contact (at the low threshold) were recorded at Montebello Islands (26% - unmitigated; 10% - mitigated), Barrow

Island (14% - unmitigated; 5% - mitigated) and Middle Island (10% - unmitigated; no contact – mitigated). Montebello Islands recorded the earliest shoreline contact (23.17 days – unmitigated; 18 days – mitigated).

During winter, the greatest probabilities of oil contact to assessed shorelines at the low threshold were recorded at Montebello Islands (10% - unmitigated; 6% - mitigated), Bessieres Island (3% - unmitigated; 1% - mitigated) and Muiron Islands (2% - unmitigated; 1% - mitigated). Additionally, Montebello Islands registered the earliest shoreline contact (19.38 days – unmitigated; 17.75 – mitigated).

Table 2-6 to Table 2-8 summarise the shoreline contact to individual receptors assessed for each season, for the unmitigated and mitigated cases.

Table 2-6 Summary of oil contact to assessed shorelines for the unmitigated and mitigated cases. Results are based on a 4,364 m³ surface release of Wandoo crude over 68 days, commencing 10 days after the start of an incident and tracked for 98 days during summer conditions. The results were calculated from 100 spill trajectories per case.

Shoreline receptor	Unmitigated															Mitigated																		
	Maximum probability of shoreline loading (%)			Minimum time before shoreline accumulation (days)			Load on shoreline (g/m ²)		Volume on shoreline (m ³)		Mean length of shoreline contact (km)			Maximum length of shoreline contact (km)			Maximum probability of shoreline loading (%)			Minimum time before shoreline accumulation (days)			Load on shoreline (g/m ²)		Volume on shoreline (m ³)		Mean length of shoreline contact (km)			Maximum length of shoreline contact (km)				
	Low	Mod.	High	Low	Mod.	High	Mean	Peak	Mean	Peak	Low	Mod.	High	Low	Mod.	High	Low	Mod.	High	Low	Mod.	High	Low	Mod.	High	Mean	Peak	Mean	Peak	Low	Mod.	High	Low	Mod.
Airlie Island	2	2	-	47.46	49.42	-	570	611	<1	6	1	1	-	1	1	-	-	-	-	-	-	-	-	-	-	-	-	-	-	-	-	-	-	
Ashburton	1	-	-	37.33	-	-	65	71	1	73	2	-	-	2	-	-	-	-	-	-	-	-	-	-	-	-	-	-	-	-	-	-		
Barrow Island	15	15	1	22.29	22.63	42.00	254	1,011	11	138	13	9	1	42	27	1	-	-	-	-	-	-	-	-	-	-	-	-	-	-	-	-		
Bessieres Island	1	1	-	48.96	50.25	-	286	403	<1	2	2	2	-	2	2	-	-	-	-	-	-	-	-	-	-	-	-	-	-	-	-	-		
Boodie Island	5	5	-	22.79	23.83	-	415	888	1	17	2	2	-	3	3	-	-	-	-	-	-	-	-	-	-	-	-	-	-	-	-	-		
Broome	22	22	-	43.04	45.79	-	275	869	17	138	13	10	-	33	26	-	5	5	-	61.29	62.79	-	229	492	1	11	2	2	-	4	4	-		
Cape Bruguieres	2	2	-	17.38	18.04	-	820	953	1	16	2	2	-	2	2	-	1	1	-	17.50	18.13	-	293	293	<1	3	1	1	-	1	1	-		
Clerke Reef	3	3	-	39.46	61.71	-	460	545	<1	7	1	1	-	2	2	-	-	-	-	-	-	-	-	-	-	-	-	-	-	-	-	-		
Cohen Island	8	8	6	14.21	16.75	34.83	1542	2485	2	27	1	1	1	1	1	1	3	3	-	17.00	17.92	-	645	736	1	9	1	1	-	1	1	-		
Cunningham Island	5	5	1	41.88	43.21	64.50	861	1,129	1	38	2	2	3	3	3	3	-	-	-	-	-	-	-	-	-	-	-	-	-	-	-	-		
Delambre Island	1	1	-	34.71	50.13	-	472	472	-	-	1	1	-	1	1	-	-	-	-	-	-	-	-	-	-	-	-	-	-	-	-	-		
East Pilbara	5	5	-	33.00	34.04	-	318	595	2	50	7	6	-	17	14	-	2	2	-	45.00	45.63	-	173	259	1	9	4	3	-	5	4	-		
Enderby Island	4	3	-	16.58	17.96	-	176	355	1	19	5	3	-	11	5	-	-	-	-	-	-	-	-	-	-	-	-	-	-	-	-	-		
Exmouth	7	7	-	40.42	40.50	-	155	365	3	97	3	2	-	4	3	-	-	-	-	-	-	-	-	-	-	-	-	-	-	-	-	-		
Flat Island	3	3	-	34.17	35.25	-	557	652	1	17	2	2	-	3	3	-	-	-	-	-	-	-	-	-	-	-	-	-	-	-	-	-		
Gidley Island	1	1	-	30.42	43.00	-	494	494	<1	6	1	1	-	1	1	-	-	-	-	-	-	-	-	-	-	-	-	-	-	-	-	-		
Goodwyn Island	3	3	1	21.17	22.50	40.63	854	1,090	1	11	1	1	1	1	1	1	-	-	-	-	-	-	-	-	-	-	-	-	-	-	-	-		
Imperieuse Reef	3	3	1	41.46	43.21	64.38	593	1,129	1	47	3	3	3	4	4	3	-	-	-	-	-	-	-	-	-	-	-	-	-	-	-	-		
Karratha	6	6	-	52.71	60.71	-	150	436	1	43	13	9	-	20	13	-	4	4	-	52.67	74.33	-	120	224	2	20	11	8	-	13	9	-		
Keast Island	4	4	3	14.25	18.17	40.50	1294	1,840	1	19	1	1	1	1	1	1	3	2	-	17.54	18.04	-	382	563	1	7	1	1	-	1	1	-		
Kendrew Island	10	10	6	16.33	18.42	25.54	1913	3,384	4	35	1	1	1	1	1	1	1	1	-	45.50	46.42	-	628	628	<1	7	1	1	-	1	1	-		
Legendre Island	15	14	4	14.75	16.42	37.46	513	1,931	3	41	2	2	1	6	6	1	3	3	-	17.54	18.00	-	238	752	1	15	4	2	-	7	3	-		
Locker Island	1	1	-	64.67	65.92	-	532	532	<1	8	1	1	-	1	1	-	-	-	-	-	-	-	-	-	-	-	-	-	-	-	-	-		
Lowendal Island	6	5	-	22.33	23.25	-	124	555	1	27	2	2	-	6	5	-	-	-	-	-	-	-	-	-	-	-	-	-	-	-	-	-		
Malus Island	1	1	-	23.50	24.38	-	543	543	<1	11	1	1	-	1	1	-	-	-	-	-	-	-	-	-	-	-	-	-	-	-	-	-		
Mermaid Reef	4	4	-	46.83	52.67	-	448	840	1	18	3	3	-	3	3	-	-	-	-	-	-	-	-	-	-	-	-	-	-	-	-	-		
Middle Island	7	7	-	22.71	23.13	-	394	963	1	18	3	3	-	4	4	-	-	-	-	-	-	-	-	-	-	-	-	-	-	-	-	-		
Montebello Islands	22	20	5	16.83	20.25	27.67	329	1,482	15	134	8	8	1	20	18	2	11	10	-	17.33	23.33	-	189	461	3	33	3	3	-	13	10	-		
Murion Islands	2	2	-	59.33	68.96	-	339	676	1	61	4	3	-	4	4	-	-	-	-	-	-	-	-	-	-	-	-	-	-	-	-	-		
Observation Island	1	1	-	48.83	49.50	-	581	581	-	-	1	1	-	1	1	-	-	-	-	-	-	-	-	-	-	-	-	-	-	-	-	-		
Port Hedland	9	9	-	34.71	34.83	-	231	955	3	51	4	3	-	8	6	-	2	2	-	44.92	45.71	-	149	315	1	8	4	4	-	5	5	-		
Rivoli Islands	1	1	-	50.21	50.75	-	99	161	-	-	2	1	-	2	1	-	-	-	-	-	-	-	-	-	-	-	-	-	-	-	-	-		
Rosemary Island	11	11	-	15.33	15.79	34.25	477	2,038	7	74	6	5	2	13	11	5	3	3	-	16.54	17.50	-	324	442	1	9	2	1	-	3	2	-		

2.3 In Water Exposure

2.3.1 *Dissolved Hydrocarbons*

Tables 2-9 to Table 2-17 summarise the probability of exposure to receptors from instantaneous dissolved hydrocarbons in the 0-10 m, 10-20 m and 20-30 m depth layers, across all seasonal conditions, at the low (10-50 ppb), moderate (50-400 ppb) and high (≥ 400 ppb) thresholds.

The seasonal stochastic modelling demonstrated an overall increase of the dissolved hydrocarbon exposure concentrations within the 0-10 m, 10-20 m and 20-30 m depth layers following the application of surface dispersant. However, the extents remain the same when compared to the unmitigated results. It is worth noting that none of the receptors assessed were predicted to be exposed at, or above the high thresholds.

In the surface (0-10 m) depth layer, the probabilities of low instantaneous dissolved hydrocarbon exposure was predicted at the Northwest Shelf IMCRA, ranged from 1% (transitional and winter) to 2% (summer), (compared to 1-2% for the mitigated case). While a probability of low instantaneous dissolved hydrocarbon exposure of 1% (all seasons) for the Montebello AMP (compared to 1-2% for the mitigated case).

In the 10-20 m depth layer, the Northwest Shelf IMCRA also recorded probabilities low dissolved hydrocarbon exposure of up to 2% for the unmitigated case and 2%, for the mitigated option.

In the 20-30 m depth layer, the Northwest Shelf IMCRA and Montebello AMP recorded probabilities low dissolved hydrocarbon exposure of up to 1% for the unmitigated case and 1%, for the mitigated option.

Table 2-9 Probability of exposure to individual receptors from instantaneous dissolved hydrocarbons in the 0-10 m depth layer, for the unmitigated and mitigated cases. Results are based on a 4,364 m³ surface release of Wandoo crude over 68 days, commencing 10 days after the start of an incident and tracked for 98 days during summer conditions.

0-10 m depth layer		Maximum dissolved hydrocarbon exposure (ppb)	Unmitigated			Maximum dissolved hydrocarbon exposure (ppb)	Mitigated		
			Probability of hydrocarbon exposure				Probability of hydrocarbon exposure		
Receptor			Low	Mod.	High		Low	Mod.	High
AMP	Gascoyne	6	-	-	-	13	1	-	-
	Montebello	12	1	-	-	13	1	-	-
	Ningaloo	6	-	-	-	10	1	-	-
IMCRA	Pilbara (nearshore)	8	-	-	-	12	1	-	-
	Northwest Shelf	34	2	-	-	16	2	-	-
KEF	Commonwealth waters adjacent to Ningaloo Reef	6	-	-	-	10	1	-	-
	Glomar Shoals	22	1	-	-	13	1	-	-
	Ancient coastline at 125 m depth contour	20	1	-	-	9	-	-	-
	Continental Slope Demersal Fish Communities	16	1	-	-	13	1	-	-
MP	Montebello Islands	9	-	-	-	13	1	-	-
State Waters	Western Australia State Waters	15	1	-	-	17	1	-	-

Table 2-10 Probability of exposure to individual receptors from instantaneous dissolved hydrocarbons in the 0-10 m depth layer, for the unmitigated and mitigated cases. Results are based on a 4,364 m³ surface release of Wandoo crude over 68 days, commencing 10 days after the start of an incident and tracked for 98 days during transitional conditions.

0-10 m depth layer		Maximum dissolved hydrocarbon exposure (ppb)	Unmitigated			Maximum dissolved hydrocarbon exposure (ppb)	Mitigated		
			Probability of hydrocarbon exposure				Probability of hydrocarbon exposure		
Receptor			Low	Mod.	High		Low	Mod.	High
AMP	Montebello	12	1	-	-	21	2	-	-
IMCRA	Northwest Shelf	12	1	-	-	21	1	-	-
KEF	Ancient coastline at 125 m depth contour	13	1	-	-	12	1	-	-
	Continental Slope Demersal Fish Communities	14	1	-	-	14	1	-	-
State Waters	Western Australia State Waters	7	-	-	-	11	1	-	-



Table 2-11 Probability of exposure to individual receptors from instantaneous dissolved hydrocarbons in the 0-10 m depth layer, for the unmitigated and mitigated cases. Results are based on a 4,364 m³ surface release of Wandoo crude over 68 days, commencing 10 days after the start of an incident and tracked for 98 days during winter conditions.

0-10 m depth layer		Maximum dissolved hydrocarbon exposure (ppb)	Unmitigated			Maximum dissolved hydrocarbon exposure (ppb)	Mitigated		
			Probability of hydrocarbon exposure				Probability of hydrocarbon exposure		
Receptor			Low	Mod.	High		Low	Mod.	High
AMP	Montebello	18	1	-	-	20	2	-	-
CP	Montebello Islands	10	1	-	-	2	-	-	-
IBRA	Cape Range	12	1	-	-	3	-	-	-
IMCRA	Northwest Shelf	12	1	-	-	16	1	-	-
KEF	Ancient coastline at 125 m depth contour	15	1	-	-	12	1	-	-
	Glomar Shoals	7	-	-	-	16	1	-	-
MMA	Barrow Island	13	1	-	-	4	-	-	-
MP	Montebello Islands	11	1	-	-	7	-	-	-
RSB	Tryal Rocks	11	1	-	-	12	1	-	-
State Waters	Western Australia	16	1	-	-	9	-	-	-

Table 2-12 Probability of exposure to individual receptors from instantaneous dissolved hydrocarbons in the 10-20 m depth layer, for the unmitigated and mitigated cases. Results are based on a 4,364 m³ surface release of Wandoo crude over 68 days, commencing 10 days after the start of an incident and tracked for 98 days during summer conditions.

10-20 m depth layer		Maximum dissolved hydrocarbon exposure (ppb)	Unmitigated			Maximum dissolved hydrocarbon exposure (ppb)	Mitigated		
			Probability of hydrocarbon exposure				Probability of hydrocarbon exposure		
Receptor			Low	Mod.	High		Low	Mod.	High
AMP	Gascoyne	4	-	-	-	10	1	-	-
	Montebello	17	1	-	-	13	1	-	-
	Ningaloo	4	-	-	-	12	1	-	-
CP	Montebello Islands	10	1	-	-	4	-	-	-
IBRA	Cape Range	10	1	-	-	5	-	-	-
IMCRA	Northwest Shelf	113	2	1	-	19	2	-	-
KEF	Ancient coastline at 125 m depth contour	70	1	1	-	9	-	-	-
	Commonwealth waters adjacent to Ningaloo Reef	4	-	-	-	12	1	-	-
	Continental Slope Demersal Fish Communities	14	2	-	-	12	1	-	-
	Glomar Shoals	19	1	-	-	8	-	-	-

10-20 m depth layer		Maximum dissolved hydrocarbon exposure (ppb)	Unmitigated			Maximum dissolved hydrocarbon exposure (ppb)	Mitigated		
			Probability of hydrocarbon exposure				Probability of hydrocarbon exposure		
Receptor			Low	Mod.	High		Low	Mod.	High
MP	Montebello Islands	12	1	-	-	8	-	-	-
State Waters	Western Australia State Waters	12	1	-	-	14	1	-	-

Table 2-13 Probability of exposure to individual receptors from instantaneous dissolved hydrocarbons in the 10-20 m depth layer, for the unmitigated and mitigated cases. Results are based on a 4,364 m³ surface release of Wandoo crude over 68 days, commencing 10 days after the start of an incident and tracked for 98 days during transitional conditions.

10-20 m depth layer		Maximum dissolved hydrocarbon exposure (ppb)	Unmitigated			Maximum dissolved hydrocarbon exposure (ppb)	Mitigated		
			Probability of hydrocarbon exposure				Probability of hydrocarbon exposure		
Receptor			Low	Mod.	High		Low	Mod.	High
AMP	Montebello	17	1	-	-	20	3	-	-
IMCRA	Northwest Shelf	12	1	-	-	15	1	-	-
KEF	Continental Slope Demersal Fish Communities	9	-	-	-	11	1	-	-
RSB	Tryal Rocks	7	-	-	-	16	1	-	-
State Waters	Western Australia State Waters	7	-	-	-	11	1	-	-

Table 2-14 Probability of exposure to individual receptors from instantaneous dissolved hydrocarbons in the 10-20 m depth layer, for the unmitigated and mitigated cases. Results are based on a 4,364 m³ surface release of Wandoo crude over 68 days, commencing 10 days after the start of an incident and tracked for 98 days during winter conditions.

10-20 m depth layer		Maximum dissolved hydrocarbon exposure (ppb)	Unmitigated			Maximum dissolved hydrocarbon exposure (ppb)	Mitigated		
			Probability of hydrocarbon exposure				Probability of hydrocarbon exposure		
Receptor			Low	Mod.	High		Low	Mod.	High
AMP	Montebello	15	1	-	-	21	1	-	-
IMCRA	Northwest Shelf	14	1	-	-	13	2	-	-
KEF	Ancient coastline at 125 m depth contour	9	-	-	-	12	2	-	-
	Continental Slope Demersal Fish Communities	5	-	-	-	10	1	-	-
	Glomar Shoals	9	-	-	-	11	1	-	-
State Waters	Western Australia	9	-	-	-	10	1	-	-

Table 2-15 Probability of exposure to individual receptors from instantaneous dissolved hydrocarbons in the 20-30 m depth layer, for the unmitigated and mitigated cases. Results are based on a 4,364 m³ surface release of Wandoo crude over 68 days, commencing 10 days after the start of an incident and tracked for 98 days during summer conditions.

20-30 m depth layer		Maximum dissolved hydrocarbon exposure (ppb)	Unmitigated			Maximum dissolved hydrocarbon exposure (ppb)	Mitigated		
			Probability of hydrocarbon exposure				Probability of hydrocarbon exposure		
Receptor			Low	Mod.	High		Low	Mod.	High
IMCRA	Northwest Shelf	139	1	1	-	13	1	-	-
	Glomar Shoals	17	1	-	-	6	-	-	-
KEF	Ancient coastline at 125 m depth contour	108	1	1	-	16	1	-	-
	Continental Slope Demersal Fish Communities	20	1	-	-	7	-	-	-

Table 2-16 Probability of exposure to individual receptors from instantaneous dissolved hydrocarbons in the 20-30 m depth layer, for the unmitigated and mitigated cases. Results are based on a 4,364 m³ surface release of Wandoo crude over 68 days, commencing 10 days after the start of an incident and tracked for 98 days during transitional conditions.

20-30 m depth layer		Maximum dissolved hydrocarbon exposure (ppb)	Unmitigated			Maximum dissolved hydrocarbon exposure (ppb)	Mitigated		
			Probability of hydrocarbon exposure				Probability of hydrocarbon exposure		
Receptor			Low	Mod.	High		Low	Mod.	High
AMP	Montebello	11	1	-	-	14	1	-	-

Table 2-17 Probability of exposure to individual receptors from instantaneous dissolved hydrocarbons in the 20-30 m depth layer, for the unmitigated and mitigated cases. Results are based on a 4,364 m³ surface release of Wandoo crude over 68 days, commencing 10 days after the start of an incident and tracked for 98 days during winter conditions.

20-30 m depth layer		Maximum dissolved hydrocarbon exposure (ppb)	Unmitigated			Maximum dissolved hydrocarbon exposure (ppb)	Mitigated		
			Probability of hydrocarbon exposure				Probability of hydrocarbon exposure		
Receptor			Low	Mod.	High		Low	Mod.	High
AMP	Montebello	12	1	-	-	11	1	-	-
IMCRA	Northwest Shelf	8	-	-	-	10	1	-	-
MMA	Barrow Island	11	1	-	-	2	-	-	-
MP	Montebello Islands	11	1	-	-	4	-	-	-
State Waters	Western Australia	11	1	-	-	5	-	-	-



2.3.2 *Entrained Hydrocarbons*

Tables 2-18 to Table 2-23 summarise the probability of exposure to individual receptors from instantaneous entrained hydrocarbons in the 0-10 m and 10-20 m depth layers across all seasonal conditions, at the low (10-100 ppb) and high (≥ 100 ppb) exposure thresholds.

The seasonal stochastic modelling demonstrated an overall increase of the instantaneous entrained hydrocarbon exposure concentrations within the 0-10 m and 10-20 m depth layers following the application of surface dispersant.

During summer conditions, the receptors predicted to have the greatest probabilities of low exposure in the surface layer (0-10 m) were: Northwest Shelf IMCRA (100% - unmitigated and mitigated), Glomar Shoals KEF (85% - unmitigated; 90% - mitigated), Ancient coastline at 125 m depth contour KEF (78% - unmitigated; 81% - mitigated) and Montebello AMP (63% - unmitigated; 70% - mitigated).

In the transitional months, the receptors predicted to have the greatest probabilities in the surface layer (0-10 m) were: Montebello AMP (100% - unmitigated and mitigated), Northwest Shelf IMCRA (100% - unmitigated and mitigated), Ancient coastline at 125 m depth contour KEF (100% - unmitigated and mitigated), Tryal Rocks RSB (99% - unmitigated; 100% - mitigated) and Continental slope demersal fish communities KEF (98% - unmitigated; 100% - mitigated).

During winter conditions, the receptors predicted to have the greatest probabilities in the surface layer (0-10 m) were: Northwest Shelf IMCRA (100% - unmitigated and mitigated), Ancient coastline at 125 m depth contour KEF (84% - unmitigated; 95% - mitigated), Montebello AMP (94% - unmitigated; 94% - mitigated) and Glomar Shoals KEF (93% - unmitigated; 94% - mitigated).

In the 10-20 m depth layer the greatest probabilities of contact in the mitigated case was predicted at the Northwest Shelf IMCRA, with probabilities of 27%, 16% and 27% predicted in the summer, transitional and winter seasons, respectively. In the 10-20 m depth layer, no contact was predicted at any receptor in the unmitigated case.

Table 2-18 Probability of exposure to individual receptors from instantaneous entrained hydrocarbons in the 0-10 m depth layer, for the unmitigated and mitigated cases. Results are based on a 4,364 m³ surface release of Wandoo crude over 68 days, commencing 10 days after the start of an incident and tracked for 98 days during summer conditions.

0-10 m depth layer Receptor	Maximum entrained hydrocarbon exposure (ppb)	Unmitigated		Mitigated			
		Probability of hydrocarbon exposure		Maximum entrained hydrocarbon exposure (ppb)	Probability of hydrocarbon exposure		
		Low	High		Low	High	
	Abrolhos	5	-	-	15	1	-
	Argo-Rowley Terrace	15	2	-	22	6	-
	Carnarvon Canyon	4	-	-	14	2	-
	Dampier	34	13	-	49	18	-
AMP	Eighty Mile Beach	15	8	-	19	5	-
	Gascoyne	41	17	-	86	37	-
	Montebello	140	63	6	249	70	16
	Ningaloo	23	8	-	70	36	-
	Shark Bay	4	-	-	10	1	-
CP	Montebello Islands	105	28	1	198	30	7
IBRA	Cape Range	127	30	2	215	33	7
	Roebourne	84	7	-	89	13	-
	Eighty Mile Beach	11	1	-	7	-	-
	Ningaloo	20	9	-	73	36	-
IMCRA	Northwest Shelf	322	100	86	379	100	99
	Pilbara (nearshore)	135	27	3	126	31	3
	Zuytdorp	5	-	-	11	1	-
	Ancient coastline at 125 m depth contour	108	78	1	143	81	5
	Canyons linking the Cuvier Abyssal Plain and the Cape Range Peninsula	41	19	-	85	40	-
KEF	Commonwealth waters adjacent to Ningaloo Reef	23	8	-	70	36	-
	Continental Slope Demersal Fish Communities	121	35	2	168	64	3
	Exmouth Plateau	28	8	-	26	7	-
	Glomar Shoals	97	85	-	122	90	4
MMA	Barrow Island	94	30	-	96	33	-
	Muiron Islands	30	8	-	19	13	-
	Barrow Island	37	26	-	67	25	-
MP	Montebello Islands	140	33	5	265	42	9
	Ningaloo	25	7	-	73	18	-
NR	Great Sandy Island	8	-	-	14	9	-

0-10 m depth layer		Unmitigated			Mitigated		
		Maximum entrained hydrocarbon exposure (ppb)	Probability of hydrocarbon exposure		Maximum entrained hydrocarbon exposure (ppb)	Probability of hydrocarbon exposure	
Receptor	Low		High	Low		High	
RSB	Thevenard Island	18	3	-	14	3	-
	Barrow Island Reefs and Shoals	8	-	-	18	9	-
	Brewis Reef	12	1	-	9	-	-
	Glomar Shoal	57	61	-	112	68	2
	Lightfoot Reef	6	-	-	12	3	-
	Madeleine Shoals	34	10	-	42	18	-
	Montebello Shoals	105	28	1	156	32	6
	Ningaloo Reef	15	5	-	65	12	-
	Penguin Bank	25	6	-	16	9	-
	Rankin Bank	35	29	-	67	60	-
	Ripple Shoals	19	6	-	16	6	-
	Rosily Shoals	19	4	-	16	6	-
	Tryal Rocks	31	31	-	82	45	-
State Waters	Western Australia	140	39	5	265	43	11

Table 2-19 Probability of exposure to individual receptors from instantaneous entrained hydrocarbons in the 0-10 m depth layer, for the unmitigated and mitigated cases. Results are based on a 4,364 m³ surface release of Wandoo crude over 68 days, commencing 10 days after the start of an incident and tracked for 98 days during transitional conditions.

0-10 m depth layer		Unmitigated			Mitigated		
		Maximum entrained hydrocarbon exposure (ppb)	Probability of hydrocarbon exposure		Maximum entrained hydrocarbon exposure (ppb)	Probability of hydrocarbon exposure	
Receptor	Low		High	Low		High	
AMP	Carnarvon Canyon	6	-	-	14	1	-
	Dampier	32	5	-	19	2	-
	Gascoyne	64	40	-	73	69	-
	Montebello	174	100	15	228	100	41
	Ningaloo	32	23	-	84	60	-
	Shark Bay	7	-	-	18	6	-
CP	Montebello Islands	37	24	-	36	33	-
IBRA	Cape Range	41	30	-	73	50	-
	Roebourne	36	7	-	30	14	-
IMCRA	Ningaloo	26	44	-	76	81	-
	Northwest Shelf	300	100	93	375	100	99
	Pilbara (nearshore)	40	7	-	35	6	-
	Zuytdorp	11	1	-	18	7	-



0-10 m depth layer		Unmitigated			Mitigated		
		Maximum entrained hydrocarbon exposure (ppb)	Probability of hydrocarbon exposure		Maximum entrained hydrocarbon exposure (ppb)	Probability of hydrocarbon exposure	
Receptor	Low		High	Low		High	
KEF	Ancient coastline at 125 m depth contour	170	100	5	177	100	12
	Canyons linking the Cuvier Abyssal Plain and the Cape Range Peninsula	64	55	-	91	84	-
	Commonwealth waters adjacent to Ningaloo Reef	32	23	-	84	60	-
	Continental Slope Demersal Fish Communities	187	98	3	201	100	7
	Exmouth Plateau	44	35	-	96	38	-
	Glomar Shoals	51	54	-	62	43	-
	Western demersal slope and associated fish communities	6	-	-	12	1	-
MMA	Barrow Island	43	51	-	62	69	-
	Muiron Islands	31	13	-	66	26	-
MP	Barrow Island	27	17	-	54	24	-
	Montebello Islands	51	87	-	75	97	-
	Ningaloo	26	8	-	77	35	-
NR	Thevenard Island	14	2	-	19	6	-
RSB	Barrow Island Reefs and Shoals	12	2	-	3	-	-
	Brewis Reef	9	-	-	12	3	-
	Glomar Shoal	37	11	-	24	9	-
	Madeleine Shoals	30	5	-	13	2	-
	Montebello Shoals	33	22	-	47	37	-
	Ningaloo Reef	26	4	-	67	19	-
	Penguin Bank	15	12	-	18	19	-
	Rankin Bank	56	49	-	49	74	-
	Ripple Shoals	25	6	-	8	-	-
	Rosily Shoals	16	3	-	21	11	-
Tryal Rocks	53	99	-	132	100	5	
State Waters	Western Australia State Waters	51	89	-	77	98	-

Table 2-20 Probability of exposure to individual receptors from instantaneous entrained hydrocarbons in the 0-10 m depth layer, for the unmitigated and mitigated cases. Results are based on a 4,364 m³ surface release of Wandoo crude over 68 days, commencing 10 days after the start of an incident and tracked for 98 days during winter conditions. The results were calculated from 100 spill trajectories per case.

0-10 m depth layer		Unmitigated			Mitigated		
		Maximum entrained hydrocarbon exposure (ppb)	Probability of hydrocarbon exposure		Maximum entrained hydrocarbon exposure (ppb)	Probability of hydrocarbon exposure	
Receptor	Low		High	Low		High	
AMP	Argo-Rowley Terrace	20	8	-	17	6	-
	Gascoyne	31	13	-	53	22	-
	Montebello	126	94	4	163	94	17
	Ningaloo	24	2	-	68	8	-
CP	Montebello Islands	19	6	-	26	7	-
IBRA	Cape Range	28	8	-	48	18	-
	Roebourne	13	1	-	16	3	-
IMCRA	Ningaloo	22	3	-	58	5	-
	Northwest Shelf	327	100	98	368	100	100
	Pilbara (nearshore)	11	1	-	27	2	-
KEF	Ancient coastline at 125 m depth contour	121	84	3	164	95	15
	Canyons linking the Cuvier Abyssal Plain and the Cape Range Peninsula	35	8	-	82	14	-
	Commonwealth waters adjacent to Ningaloo Reef	24	2	-	68	8	-
	Continental Slope Demersal Fish Communities	86	67	-	140	91	7
	Exmouth Plateau	30	10	-	35	21	0
	Glomar Shoals	92	93	-	115	94	4
MMA	Barrow Island	30	20	-	45	25	-
	Muiron Islands	27	3	-	61	5	-
MP	Barrow Island	13	2	-	24	16	-
	Montebello Islands	38	45	-	58	54	-
RSB	Ningaloo	24	2	-	63	2	-
	Glomar Shoal	47	55	-	79	79	-
	Montebello Shoals	21	6	-	30	12	-
	Ningaloo Reef	17	2	-	43	2	-
	Penguin Bank	19	8	-	28	11	-
	Rankin Bank	46	49	-	76	76	-
	Ripple Shoals	7	-	-	11	1	-
	Rosily Shoals	8	-	-	10	2	-
	Tryal Rocks	54	65	-	67	73	-



0-10 m depth layer		Unmitigated			Mitigated		
		Maximum entrained hydrocarbon exposure (ppb)	Probability of hydrocarbon exposure		Maximum entrained hydrocarbon exposure (ppb)	Probability of hydrocarbon exposure	
Receptor	Low		High	Low		High	
State Waters	Western Australia	60	46	-	64	54	-

Table 2-21 Probability of exposure to individual receptors from instantaneous entrained hydrocarbons in the 10-20 m depth layer, for the unmitigated and mitigated cases. Results are based on a 4,364 m³ surface release of Wandoo crude over 68 days, commencing 10 days after the start of an incident and tracked for 98 days during summer conditions.

10-20 m depth layer		Unmitigated			Mitigated		
		Maximum entrained hydrocarbon exposure (ppb)	Probability of hydrocarbon exposure		Maximum entrained hydrocarbon exposure (ppb)	Probability of hydrocarbon exposure	
Receptor	Low		High	Low		High	
AMP	Gascoyne	5	-	-	14	3	-
	Montebello	6	-	-	20	8	-
	Ningaloo	3	-	-	12	2	-
IBRA	Cape Range	4	-	-	10	1	-
IMCRA	Ningaloo	3	-	-	11	2	-
	Northwest Shelf	9	-	-	20	27	-
KEF	Ancient coastline at 125 m depth contour	6	-	-	18	7	-
	Canyons linking the Cuvier Abyssal Plain and the Cape Range Peninsula	6	-	-	13	3	-
	Commonwealth waters adjacent to Ningaloo Reef	3	-	-	12	2	-
	Continental Slope Demersal Fish Communities	7	-	-	15	4	-
	Glomar Shoals	6	-	-	15	5	-
MP	Montebello Islands	5	-	-	16	4	-
RSB	Glomar Shoal	4	-	-	10	1	-
	Tryal Rocks	2	-	-	10	1	-
State Waters	Western Australia State Waters	5	-	-	23	7	-

Table 2-22 Probability of exposure to individual receptors from instantaneous entrained hydrocarbons in the 10-20 m depth layer, for the unmitigated and mitigated cases. Results are based on a 4,364 m³ surface release of Wandoo crude over 68 days, commencing 10 days after the start of an incident and tracked for 98 days during transitional conditions.

10-20 m depth layer		Unmitigated			Mitigated		
		Maximum entrained hydrocarbon exposure (ppb)	Probability of hydrocarbon exposure		Maximum entrained hydrocarbon exposure (ppb)	Probability of hydrocarbon exposure	
Receptor	Low		High	Low		High	
AMP	Gascoyne	5	-	-	15	4	-
	Montebello	7	-	-	23	22	-
	Ningaloo	5	-	-	12	2	-
IBRA	Cape Range	3	-	-	11	1	-
IMCRA	Ningaloo	4	-	-	13	2	-
	Northwest Shelf	7	-	-	21	16	-
KEF	Ancient coastline at 125 m depth contour	5	-	-	18	9	-
	Canyons linking the Cuvier Abyssal Plain and the Cape Range Peninsula	5	-	-	15	5	-
	Commonwealth waters adjacent to Ningaloo Reef	5	-	-	12	2	-
	Continental Slope Demersal Fish Communities	7	-	-	22	9	-
	Exmouth Plateau	6	-	-	18	5	-
MMA	Muiron Islands	3	-	-	10	1	-
MP	Ningaloo	3	-	-	13	2	-
RSB	Ningaloo Reef	3	-	-	10	1	-
	Tryal Rocks	3	-	-	14	8	-
State Waters	Western Australia State Waters	5	-	-	13	2	-

Table 2-23 Probability of exposure to individual receptors from instantaneous entrained hydrocarbons in the 10-20 m depth layer, for the unmitigated and mitigated cases. Results are based on a 4,364 m³ surface release of Wandoo crude over 68 days, commencing 10 days after the start of an incident and tracked for 98 days during winter conditions.

10-20 m depth layer		Unmitigated			Mitigated		
		Maximum entrained hydrocarbon exposure (ppb)	Probability of hydrocarbon exposure		Maximum entrained hydrocarbon exposure (ppb)	Probability of hydrocarbon exposure	
Receptor	Low		High	Low		High	
AMP	Montebello	7	-	-	15	4	-
IMCRA	Northwest Shelf	7	-	-	20	27	-
KEF	Ancient coastline at 125 m depth contour	6	-	-	20	12	-



10-20 m depth layer		Maximum entrained hydrocarbon exposure (ppb)	Unmitigated		Maximum entrained hydrocarbon exposure (ppb)	Mitigated	
			Probability of hydrocarbon exposure			Probability of hydrocarbon exposure	
Receptor			Low	High		Low	High
	Canyons linking the Cuvier Abyssal Plain and the Cape Range Peninsula	4	-	-	10	1	-
	Continental Slope Demersal Fish Communities	5	-	-	21	6	-
	Glomar Shoals	5	-	-	14	7	-
RSB	Rankin Bank	3	-	-	12	2	-
State Waters	Western Australia	4	-	-	11	1	-



2.4 Weathering and Fate

Figure 2-1 displays the time-series of the area of visible surface oil (or low threshold $>1 \text{ g/m}^2$) and actionable oil ($>10 \text{ g/m}^2$), and length of actionable shoreline oil ($>100 \text{ g/m}^2$) over the 98-day simulation, for the unmitigated and mitigated cases for the deterministic trajectory that resulted in the largest volume of oil ashore and the longest length of shoreline contacted above 100 g/m^2 . Figure 2-2 displays the fates and weathering graph for the corresponding spill trajectories (unmitigated and mitigated).

For the unmitigated case, the maximum area of coverage of visible oil on the sea surface was predicted to occur 37 days after the spill started and cover approximately 130 km^2 (compared to 35 km^2 on day-59, for the mitigated case). The maximum length of actionable shoreline oil occurred on day 43 with approximately 53 km of shoreline contacted, for the unmitigated case, compared to 5 km of shoreline contact on day 43, for the mitigated case.

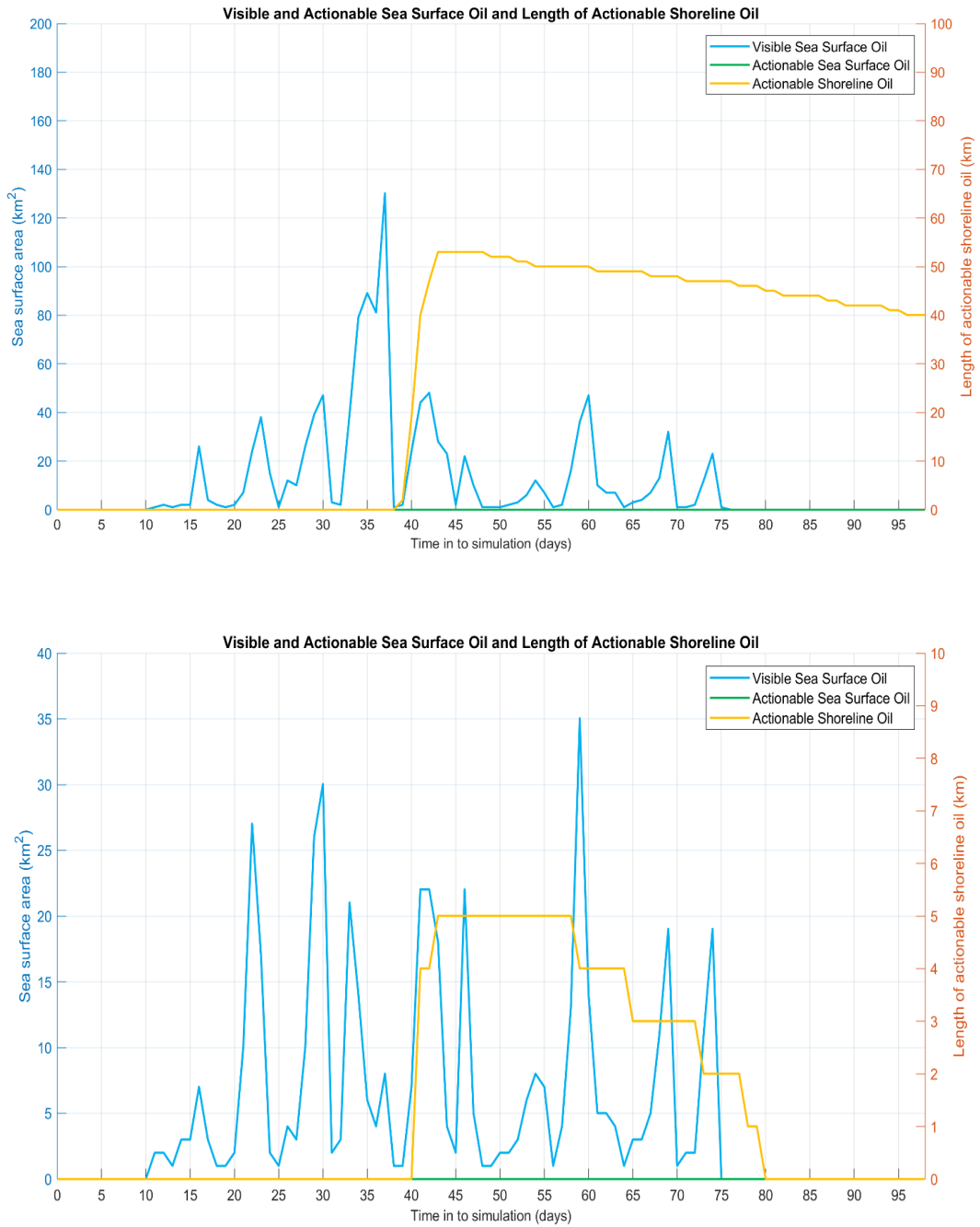

Figure 2-1 Time-series of the area of low exposure (or visible sea surface oil at 1 g/m²) and actionable (10 g/m²) surface oil (left axis) and length of actionable shoreline oil (100 g/m²; right axis) for the trajectory with the largest volume of oil ashore and the longest length of shoreline contacted above 100 g/m², for the unmitigated (upper image) and mitigated (lower image) cases.

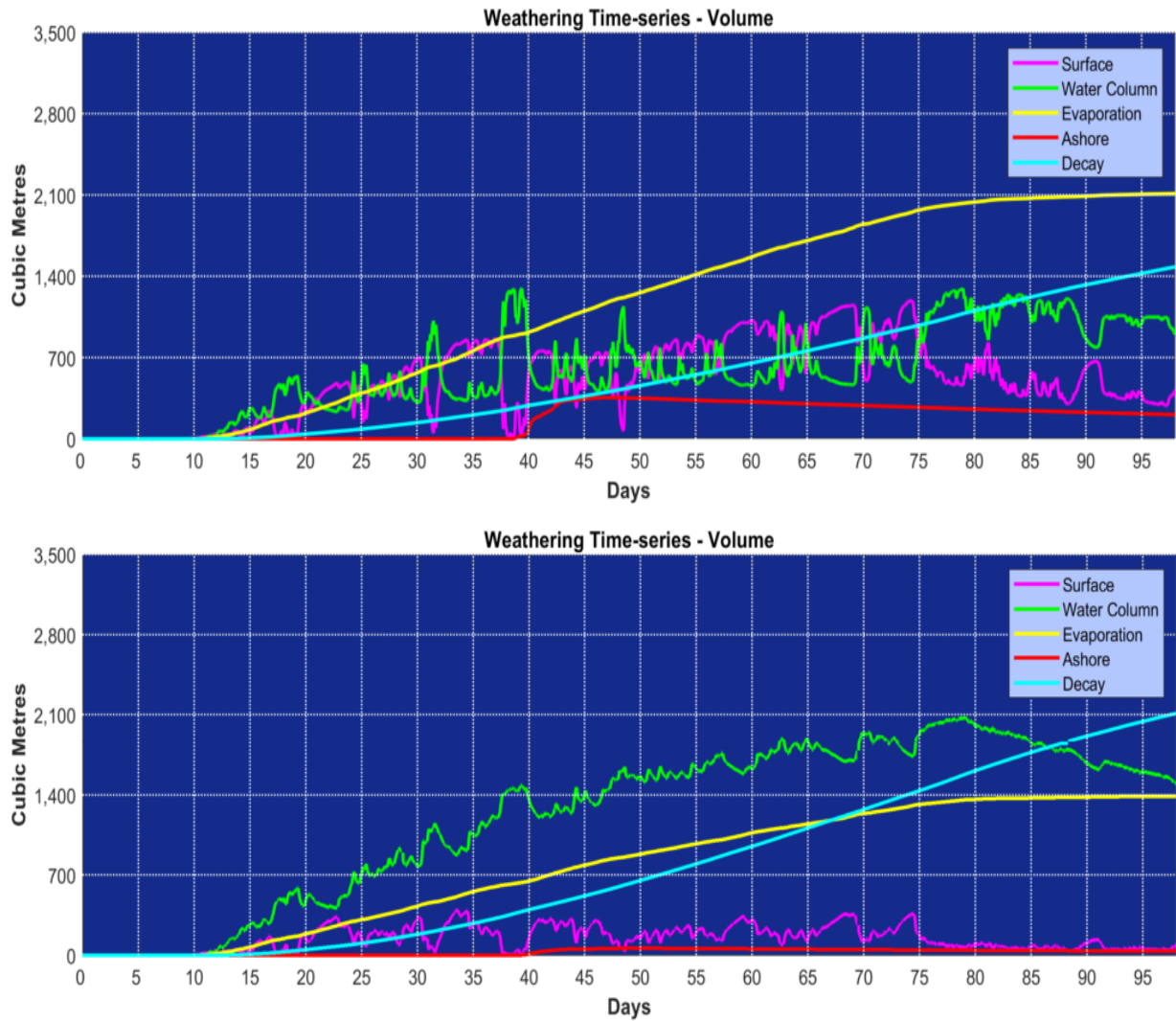

Figure 2-2 Predicted weathering and fates graph for the unmitigated (upper image) and mitigated (lower image) cases, for the trajectory with the largest volume of oil ashore and the longest length of shoreline contacted above 100 g/m².

3 LOSS OF CGS CONTAINMENT

3.1 Sea Surface Exposure

Table 3-1 summarises the maximum distances from the release location to oil exposure zones on the sea surface for each season.

The maximum distance from the release location to the low (1-10 g/m²), moderate (10-50 g/m²) and high (>50 g/m²) exposure thresholds was 2,867 km west-northwest (winter), 2,186 km northwest (winter) and 921 km east-northeast (summer), respectively.

Tables 3-2 to Table 3-4 summarise the potential sea surface exposure to individual receptors for each season. For spills commencing during summer, transitional and winter conditions, the following receptors recorded probabilities greater than 80% across all seasons (at the low threshold): Ancient coastline at 125 m depth contour KEF and the Northwest Shelf IMCRA.

Figures 3-1 to 3-11 present the zones of sea surface exposure in summer, as the season with the maximum distance from the release location for exposure to high zones of surface oil as well as having the greatest probability of shoreline impact and greatest volumes ashore. The figures show the probability of sea-surface contact (reporting threshold of 10 g/m²) at day 1, 2, 5, 10, 20, 30, 40, 50, 60, and 70.

Table 3-1 Maximum distance and direction from the release location to oil exposure thresholds on the sea surface. Results are based on a 250,000 bbl subsea release of Wandoo crude over 24 hours, tracked for 80 days during all seasonal conditions.

Season	Distance and direction travelled	Zones of potential sea surface exposure		
		Low	Moderate	High
Summer	Maximum distance (km) from release location	2,064	1,313	921
	Direction	NW	NW	ENE
Transitional	Maximum distance (km) from release location	2,606	1,755	478
	Direction	WNW	WNW	NE
Winter	Maximum distance (km) from release location	2,867	2,186	664
	Direction	WNW	NW	WNW

Table 3-2 Summary of the potential sea surface exposure to individual receptors. Results are based on a 250,000 bbl subsea release of Wandoo crude over 24 hours, tracked for 80 days during summer conditions.

Receptors	Probability of oil exposure on the sea surface (%)			Minimum time before oil exposure on the sea surface (days)			
	Low	Mod.	High	Low	Mod.	High	
AMP	Argo-Rowley Terrace	71	36	5	14.83	22.04	38.58
	Ashmore Reef	3	-	-	77.50	-	-
	Carnarvon Canyon	5	-	-	41.38	-	-
	Dampier	18	11	2	2.92	5.54	5.67
	Eighty Mile Beach	34	27	4	11.21	11.67	12.88
	Gascoyne	32	12	2	9.25	9.71	18.21
	Kimberley	35	9	1	31.79	41.17	68.75
	Mermaid Reef	32	14	2	31.88	33.04	49.08
	Montebello	41	21	15	1.25	1.46	1.83
	Ningaloo	16	5	-	12.50	30.58	-
	Roebuck	21	7	1	29.96	33.83	42.46
CP	Montebello Islands	10	2	1	3.75	8.04	11.13
EEZ	Christmas Island Exclusive Economic Zone	11	1	-	54.04	66.42	-
	Indonesian Exclusive Economic Zone	37	5	-	36.79	48.88	-
IBRA	Cape Range	20	7	3	3.54	4.67	4.79
	Chichester	8	1	-	10.54	38.13	-
	Christmas Island	1	-	-	62.54	0.00	-
	Mitchell	8	3	1	52.46	54.71	60.17
	Pindanland	39	27	7	15.17	19.38	27.25
	Roebourne	32	19	4	3.33	3.79	4.33
	Timor Sea Coral Islands	3	-	-	77.71	-	-
IMCRA	Canning	35	20	4	26.00	29.00	39.33
	Eighty Mile Beach	34	19	3	12.88	13.79	15.00
	Kimberley	15	3	1	47.79	52.04	59.46



Receptors	Probability of oil exposure on the sea surface (%)			Minimum time before oil exposure on the sea surface (days)			
	Low	Mod.	High	Low	Mod.	High	
	King Sound	4	-	-	52.71	-	-
	Ningaloo	17	6	1	12.50	17.58	36.88
	Northwest Shelf	100	100	95	0.17	0.17	0.17
	Oceanic Shoals	3	-	-	68.88	-	-
	Pilbara (nearshore)	35	22	10	2.63	2.71	2.88
	Zuytdorp	1	-	-	54.79	-	-
IPA	Nyangumarta Warrarn	18	10	1	16.13	19.38	43.46
	Ancient coastline at 125 m depth contour	97	87	56	3.00	3.54	3.79
	Ashmore Reef and Cartier Island and surrounding Commonwealth waters	4	-	-	74.63	-	-
	Canyons linking the Argo Abyssal Plain with the Scott Plateau	24	3	-	34.29	49.67	-
	Canyons linking the Cuvier Abyssal Plain and the Cape Range Peninsula	26	9	2	8.67	17.67	19.21
KEF	Commonwealth waters adjacent to Ningaloo Reef	16	5	-	12.38	30.58	-
	Continental Slope Demersal Fish Communities	71	39	16	3.58	4.00	4.75
	Exmouth Plateau	43	15	1	8.83	9.71	20.67
	Glomar Shoals	71	49	28	1.79	2.17	2.38
	Mermaid Reef and Commonwealth waters surrounding Rowley Shoals	42	20	4	23.83	25.42	38.88
	Seringapatam Reef and Commonwealth waters in the Scott Reef Complex	15	4	-	56.13	59.46	-
MMA	Barrow Island	15	6	3	3.83	4.50	6.08
	Muiron Islands	6	2	-	11.88	30.67	-
	Barrow Island	8	3	2	5.00	5.96	6.75
	Eighty Mile Beach	26	14	3	14.17	18.38	27.25
	Lalang-garram / Camden Sound	9	2	1	52.50	56.25	59.46
MP	Lalang-garram / Horizontal Falls	4	2	1	56.25	59.29	59.67
	Montebello Islands	18	8	2	3.04	3.21	4.33
	Ningaloo	14	3	-	12.25	30.67	-
	Rowley Shoals	37	13	-	25.92	26.83	-
	Yawuru Nagulagun / Roebuck Bay	21	10	2	29.96	36.50	40.29
NR	Great Sandy Island	9	2	-	8.25	10.38	-
	Scott Reef	8	-	-	59.21	-	-
	Thevenard Island	4	-	-	7.17	-	-
RAMSAR	Ashmore Reef National Nature Reserve	3	-	-	77.50	-	-
	Eighty-mile Beach	24	11	1	15.17	19.38	42.96
	Roebuck Bay	22	11	3	30.46	36.67	39.33

Receptors	Probability of oil exposure on the sea surface (%)			Minimum time before oil exposure on the sea surface (days)		
	Low	Mod.	High	Low	Mod.	High
Albert Reef	4	-	-	57.29	-	-
Barcoo Shoal	1	-	-	65.25	-	-
Barrow Island Reefs and Shoals	7	1	-	8.17	25.21	-
Baylis Patches	2	-	-	22.46	-	-
Beagle and Dingo Reefs	1	-	-	69.79	-	-
Beryl Reef	1	-	-	38.21	-	-
Brewis Reef	3	-	-	8.92	-	-
Brue Reef	5	-	-	54.04	-	-
Churchill Reef	2	-	-	66.83	-	-
Clerke Reef	26	7	-	30.63	33.75	-
Cockell and Nicolle Reefs	2	-	-	57.13	-	-
Eliassen Rocks	2	-	-	12.88	-	-
Exmouth Reef	1	-	-	37.21	-	-
Fortescue Reef	4	1	-	10.92	11.50	-
Glomar Shoal	46	24	3	3.25	4.29	6.46
Herald Reef	3	1	-	8.38	10.17	-
Imperieuse Reef	31	10	-	26.46	27.29	-
Lightfoot Reef	3	-	-	10.29	-	-
Locker Reef	3	-	-	9.17	-	-
Madeleine Shoals	12	5	1	4.42	6.58	6.67
Manicom Bank	2	-	-	9.25	-	-
Mavis Reef	1	-	-	68.21	-	-
Meda Reef	2	-	-	13.04	-	-
Mermaid Reef	28	8	2	32.46	33.08	49.08
Montebello Shoals	11	3	1	4.29	5.75	7.92
Ningaloo Reef	8	2	-	20.83	30.88	-
O'Grady Shoal	4	-	-	10.92	-	-
Paroo Shoal	3	1	-	8.75	9.04	-
Penguin Bank	4	1	-	6.08	22.83	-
Rankin Bank	35	14	7	6.88	7.46	10.42
Ripple Shoals	5	3	-	6.67	7.21	-
Rosily Shoals	4	1	-	7.08	21.04	-
South East Reef	3	1	-	3.83	4.33	-
Tongue Shoals	3	-	-	8.92	-	-
Tryal Rocks	14	4	-	3.04	6.42	-
Vaughan Shoal	1	-	-	37.00	-	-
Ward Reef	1	1	-	9.71	9.79	-
Weeks Shoal	3	1	-	8.33	9.38	-
West Reef	3	1	-	9.38	10.50	-
State Waters						
Western Australia	83	57	18	1.50	1.79	3.29

Table 3-3 Summary of the potential sea surface exposure to individual receptors. Results are based on a 250,000 bbl subsea release of Wandoo crude over 24 hours, tracked for 80 days during transitional conditions.

Receptors	Probability of oil exposure on the sea surface (%)			Minimum time before oil exposure on the sea surface (days)			
	Low	Mod.	High	Low	Mod.	High	
AMP	Abrolhos	22	3	-	28.17	75.46	-
	Argo-Rowley Terrace	6	5	1	33.04	35.79	67.63
	Carnarvon Canyon	35	4	-	20.08	48.13	-
	Eighty Mile Beach	2	-	-	25.54	-	-
	Gascoyne	88	67	12	6.04	6.63	6.96
	Kimberley	1	-	-	62.63	-	-
	Mermaid Reef	3	3	1	62.50	62.92	67.38
	Montebello	80	69	57	0.96	1.00	1.33
	Ningaloo	24	5	1	9.88	11.42	14.00
	Shark Bay	7	-	-	17.54	-	-
CP	Montebello Islands	12	3	-	3.88	4.63	-
EEZ	Christmas Island Exclusive Economic Zone	7	1	-	57.58	75.42	-
	Cocos Islands Exclusive Economic Zone	15	-	-	69.58	-	-
IBRA	Cape Range	25	10	7	3.88	4.42	4.71
	Roebourne	8	5	2	8.08	10.83	10.88
IMCRA	Canning	2	-	-	48.96	-	-
	Ningaloo	28	5	1	9.17	11.42	13.58
	Northwest Shelf	83	81	75	0.17	0.17	0.21
	Pilbara (nearshore)	8	-	-	2.58	-	-
	Zuytdorp	16	-	-	17.42	-	-
KEF	Ancient coastline at 125 m depth contour	100	99	65	2.58	2.88	3.25
	Canyons linking the Cuvier Abyssal Plain and the Cape Range Peninsula	74	43	4	6.88	7.58	13.29
	Commonwealth waters adjacent to Ningaloo Reef	24	5	1	9.88	11.42	14.00
	Continental Slope Demersal Fish Communities	98	89	52	3.13	3.38	3.67
	Exmouth Plateau	99	89	16	7.88	9.96	12.38
	Glomar Shoals	32	21	12	3.21	3.67	4.46
	Mermaid Reef and Commonwealth waters surrounding Rowley Shoals	3	3	1	62.38	62.92	67.38
	Perth Canyon and adjacent shelf break, and other west coast canyons	1	-	-	26.71	-	-
	Wallaby Saddle	20	-	-	29.63	-	-
	Western demersal slope and associated fish communities	16	-	-	20.46	-	-
MMA	Barrow Island	16	7	6	4.42	4.96	7.96
	Muiron Islands	7	1	-	7.79	15.96	-
MP	Barrow Island	8	6	5	7.13	8.13	9.96

Receptors	Probability of oil exposure on the sea surface (%)			Minimum time before oil exposure on the sea surface (days)				
	Low	Mod.	High	Low	Mod.	High		
	Montebello Islands	21	11	4	3.29	4.42	4.71	
	Ningaloo	16	2	1	10.79	12.83	13.58	
	Rowley Shoals	2	-	-	68.38	-	-	
	Clerke Reef	2	-	-	68.46	-	-	
	Fairway Reef	1	-	-	16.04	-	-	
	Glomar Shoal	21	8	2	5.50	5.54	5.67	
	Hood Reef	2	-	-	15.92	-	-	
	Imperieuse Reef	2	-	-	71.58	-	-	
	Mermaid Reef	3	3	1	62.79	62.92	67.38	
	Montebello Shoals	12	7	3	4.42	4.92	8.13	
RSB	Ningaloo Reef	7	1	-	12.17	12.83	-	
	Outtrim Patches	1	-	-	15.67	-	-	
	Poivre Reef	7	3	-	8.04	11.08	-	
	Rankin Bank	36	16	3	5.00	5.25	5.63	
	Ripple Shoals	1	-	-	15.75	-	-	
	Rosily Shoals	2	-	-	13.50	-	-	
	Taunton Reef	1	-	-	15.58	-	-	
	Tryal Rocks	28	17	3	2.04	2.92	4.67	
	State Waters	Western Australia	41	19	10	3.08	3.25	4.71

Table 3-4 Summary of the potential sea surface exposure to individual receptors. Results are based on a 250,000 bbl subsea release of Wandoo crude over 24 hours, tracked for 80 days during winter conditions.

Receptors	Probability of oil exposure on the sea surface (%)			Minimum time before oil exposure on the sea surface (days)			
	Low	Mod.	High	Low	Mod.	High	
	Abrolhos	7	-	-	30.54	-	-
	Argo-Rowley Terrace	40	13	-	18.21	18.63	-
	Carnarvon Canyon	10	-	-	25.33	-	-
	Gascoyne	69	28	1	7.54	8.21	11.58
AMP	Kimberley	1	-	-	41.42	-	-
	Mermaid Reef	4	1	-	27.04	31.46	-
	Montebello	85	80	57	0.79	0.88	1.21
	Ningaloo	17	-	-	13.92	-	-
	Shark Bay	2	-	-	29.25	-	-
CP	Montebello Islands	19	9	5	2.58	3.38	3.54
EEZ	Christmas Island Exclusive Economic Zone	64	6	-	48.13	56.75	-
	Cocos Islands Exclusive Economic Zone	33	1	-	64.17	76.00	-
	Indonesian Exclusive Economic Zone	43	7	-	39.63	41.29	-
IBRA	Cape Range	25	13	8	2.54	2.79	3.42
	Christmas Island	9	-	-	68.71	-	-

Receptors	Probability of oil exposure on the sea surface (%)			Minimum time before oil exposure on the sea surface (days)			
	Low	Mod.	High	Low	Mod.	High	
	Christmas Island	9	-	-	68.71	-	-
	Cocos Islands	1	-	-	79.58	-	-
	Roebourne	4	3	1	5.42	5.46	5.46
	Canning	1	-	-	79.33	-	-
	Ningaloo	21	1	-	7.92	9.00	-
IMCRA	Northwest Shelf	84	81	75	0.17	0.17	0.17
	Pilbara (nearshore)	6	1	-	1.96	2.08	-
	Zuytdorp	4	-	-	26.08	-	-
	Ancient coastline at 125 m depth contour	100	99	53	3.00	3.67	4.42
	Canyons linking the Argo Abyssal Plain with the Scott Plateau	12	-	-	41.54	-	-
	Canyons linking the Cuvier Abyssal Plain and the Cape Range Peninsula	56	14	1	6.25	7.75	10.79
	Commonwealth waters adjacent to Ningaloo Reef	17	-	-	13.92	-	-
	Continental Slope Demersal Fish Communities	96	84	36	3.71	4.17	4.71
KEF	Exmouth Plateau	85	55	2	8.17	8.92	15.08
	Glomar Shoals	19	15	11	1.67	1.71	1.83
	Mermaid Reef and Commonwealth waters surrounding Rowley Shoals	9	2	-	21.42	23.17	-
	Seringapatam Reef and Commonwealth waters in the Scott Reef Complex	2	-	-	70.46	-	-
	Wallaby Saddle	6	-	-	33.58	-	-
	Western demersal slope and associated fish communities	2	-	-	39.08	-	-
MMA	Barrow Island	18	9	5	3.13	3.67	4.00
	Muiron Islands	6	1	-	7.00	8.96	-
	Barrow Island	6	4	3	4.25	4.54	4.75
MP	Montebello Islands	37	17	11	2.38	2.79	3.67
	Ningaloo	10	-	-	9.50	-	-
	Rowley Shoals	9	2	-	22.33	24.08	-
NR	Thevenard Island	1	-	-	12.58	-	-
	Barrow Island Reefs and Shoals	1	-	-	14.42	-	-
	Clerke Reef	4	1	-	23.00	30.92	-
	Exmouth Reef	1	-	-	15.04	-	-
	Fairway Reef	1	-	-	14.75	-	-
RSB	Glomar Shoal	10	6	3	3.29	5.46	6.33
	Hood Reef	2	-	-	9.88	-	-
	Imperieuse Reef	7	2	-	22.63	24.71	-
	Mermaid Reef	3	-	-	30.67	-	-
	Montebello Shoals	18	8	3	2.83	3.63	4.75



Receptors	Probability of oil exposure on the sea surface (%)			Minimum time before oil exposure on the sea surface (days)		
	Low	Mod.	High	Low	Mod.	High
Ningaloo Reef	3	-	-	15.96	-	-
Outtrim Patches	3	1	-	8.88	9.29	-
Pearl Reef	2	-	-	14.58	-	-
Poivre Reef	4	3	-	5.04	5.54	-
Rankin Bank	44	27	7	3.71	5.42	5.58
Ripple Shoals	1	-	-	13.46	-	-
Rosily Shoals	3	-	-	11.50	-	-
Taunton Reef	1	-	-	12.17	-	-
Tryal Rocks	46	28	6	2.29	2.67	4.63
State Waters						
Western Australia	54	29	13	1.46	1.75	1.75

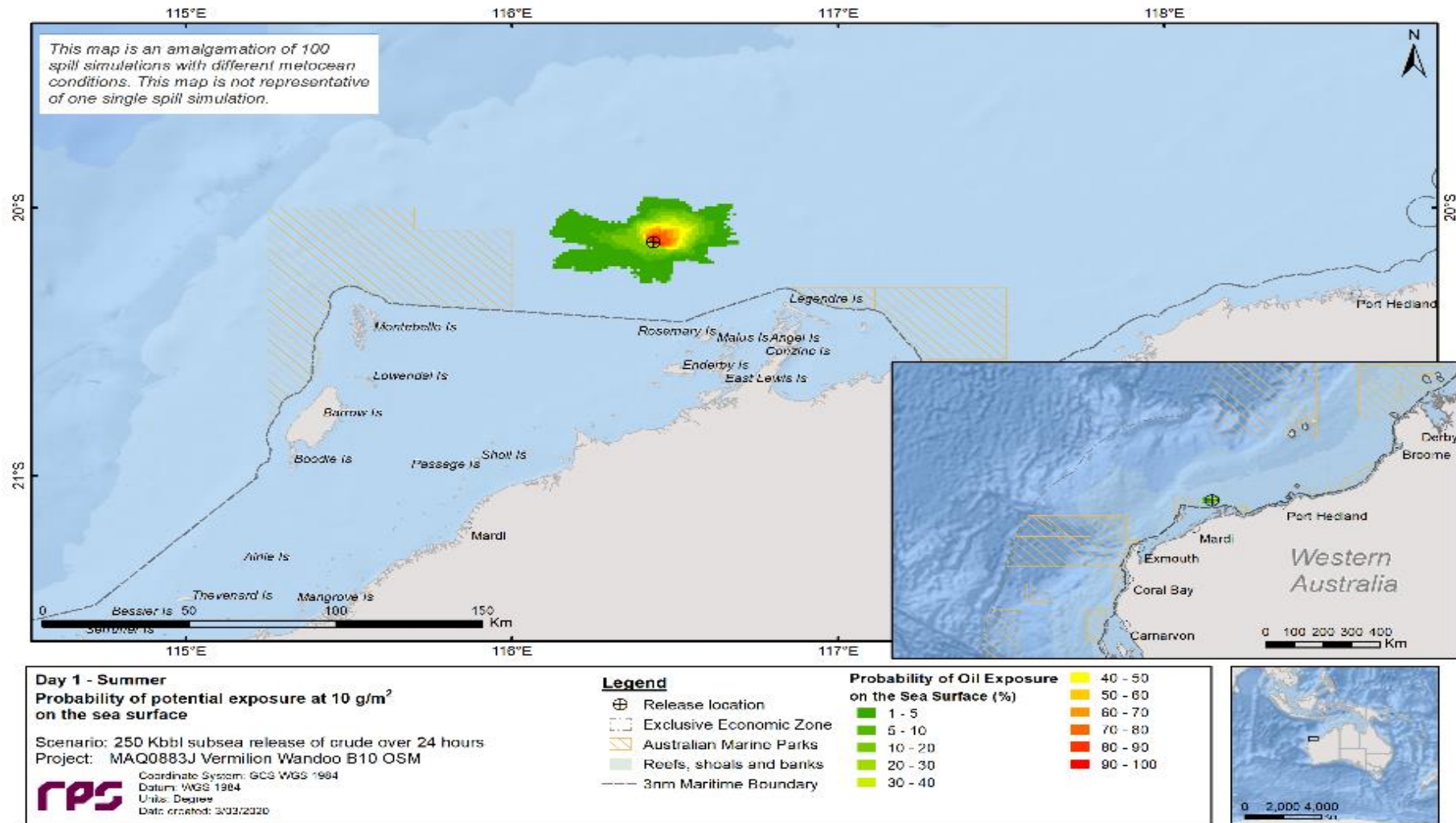

Figure 3-1 Probability of sea-surface exposure (above 10 g/m²) at day 1 during summer conditions

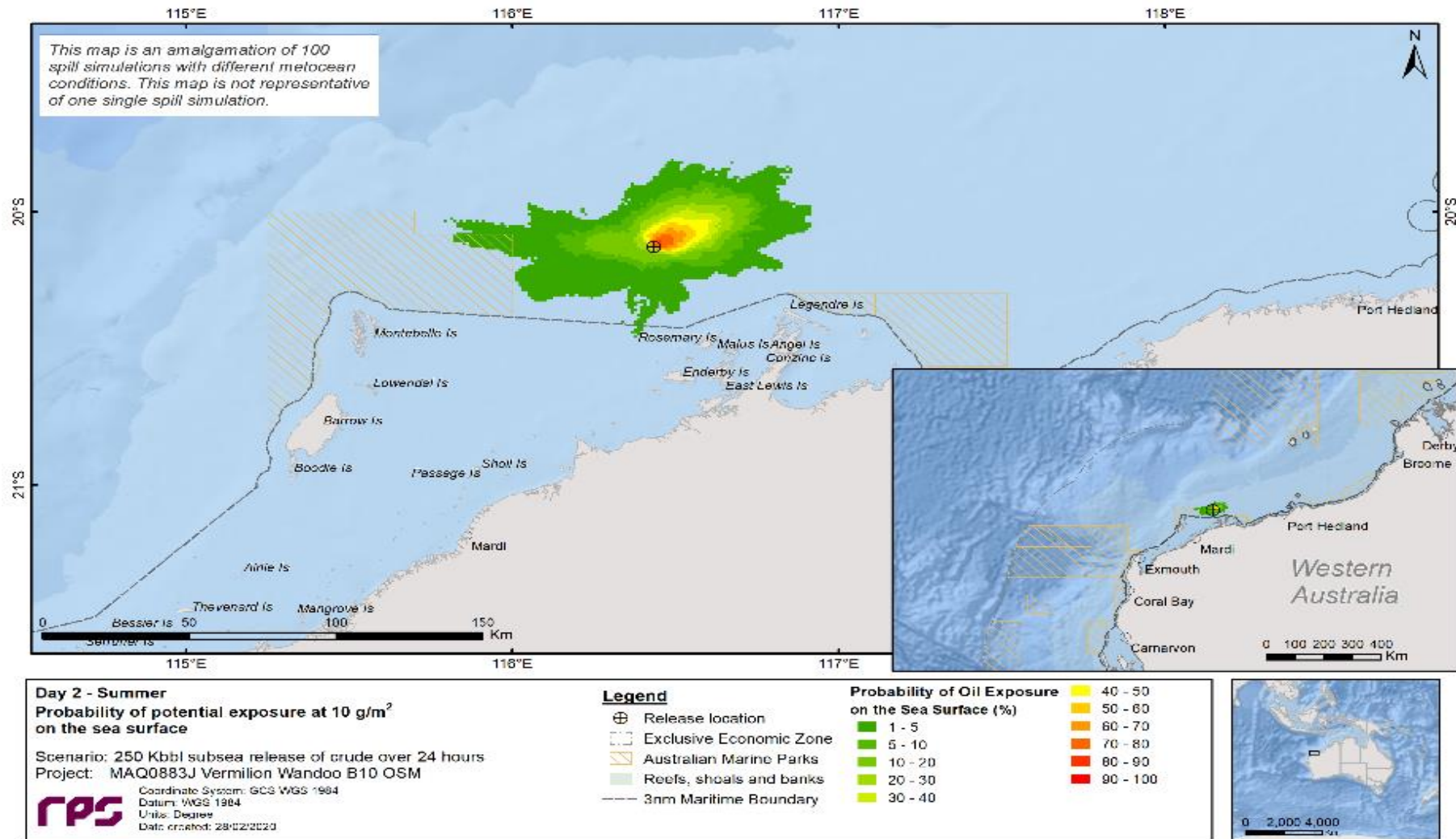

Figure 3-2 Probability of sea-surface exposure (above 10 g/m²) at day 2 during summer conditions

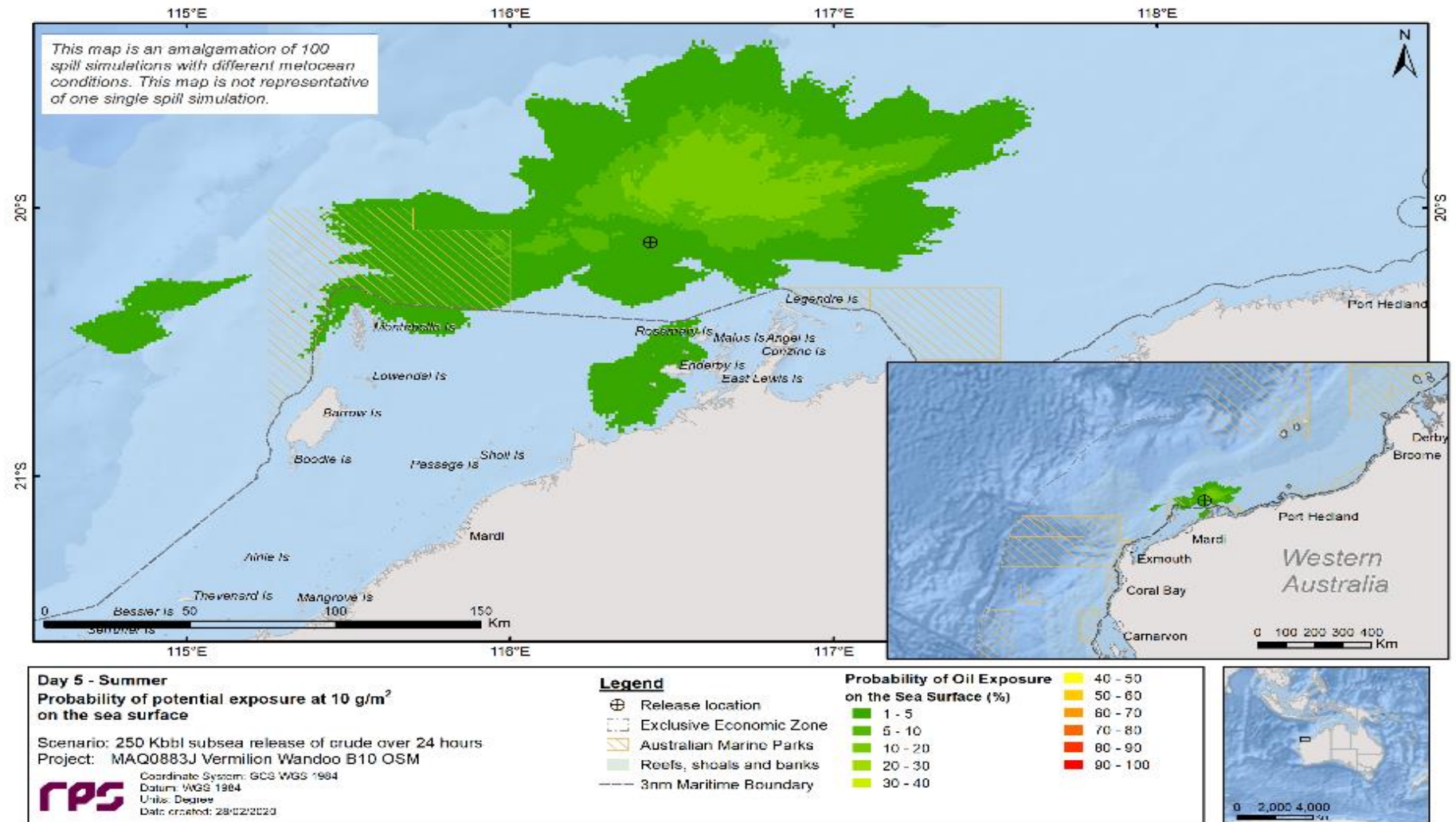

Figure 3-3 Probability of sea-surface exposure (above 10 g/m²) at day 5 during summer conditions

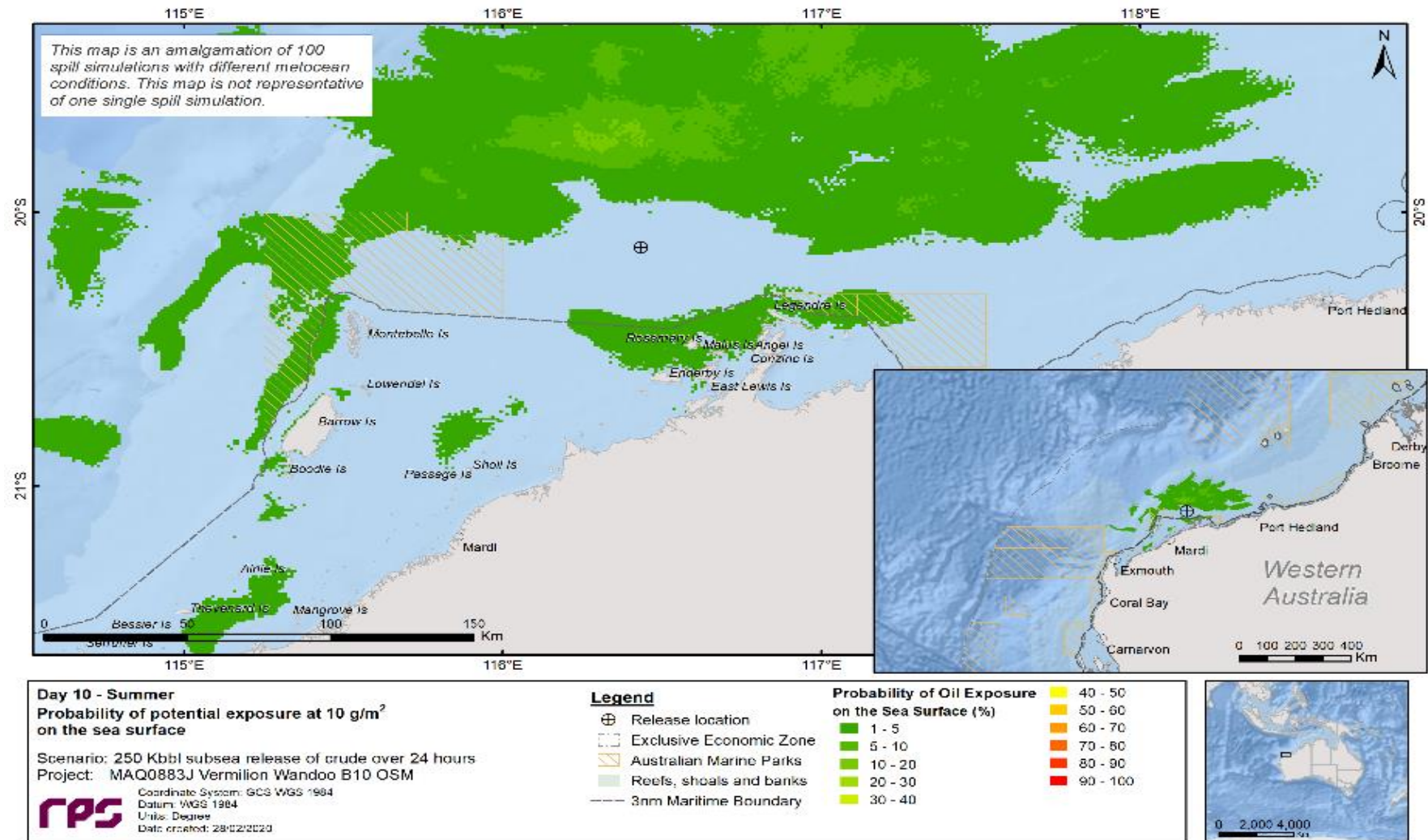

Figure 3-4 Probability of sea-surface exposure (above 10 g/m²) at day 10 during summer conditions

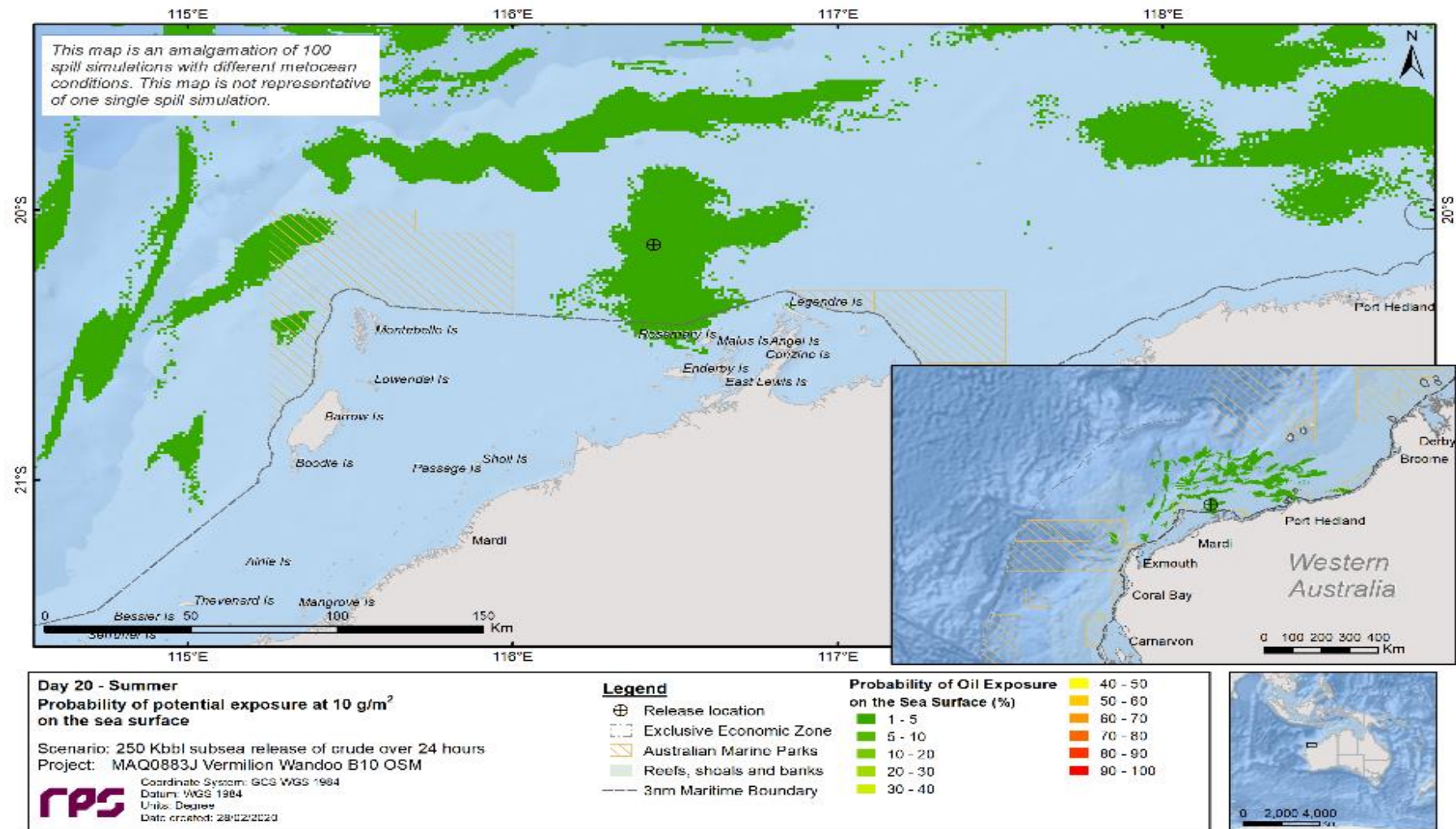

Figure 3-5 Probability of sea-surface exposure (above 10 g/m²) at day 20 during summer conditions

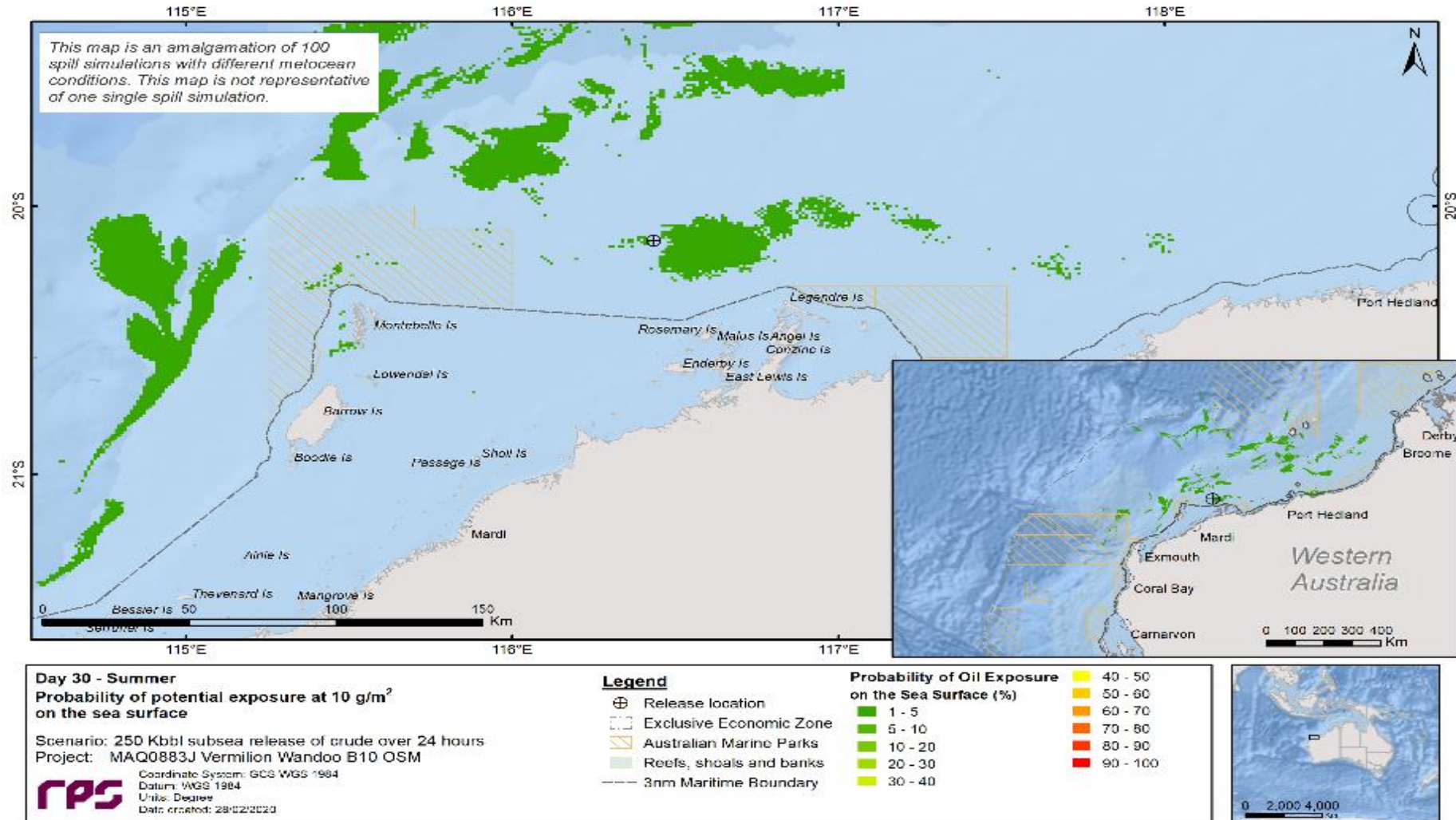

Figure 3-6 Probability of sea-surface exposure (above 10 g/m²) at day 30 during summer conditions

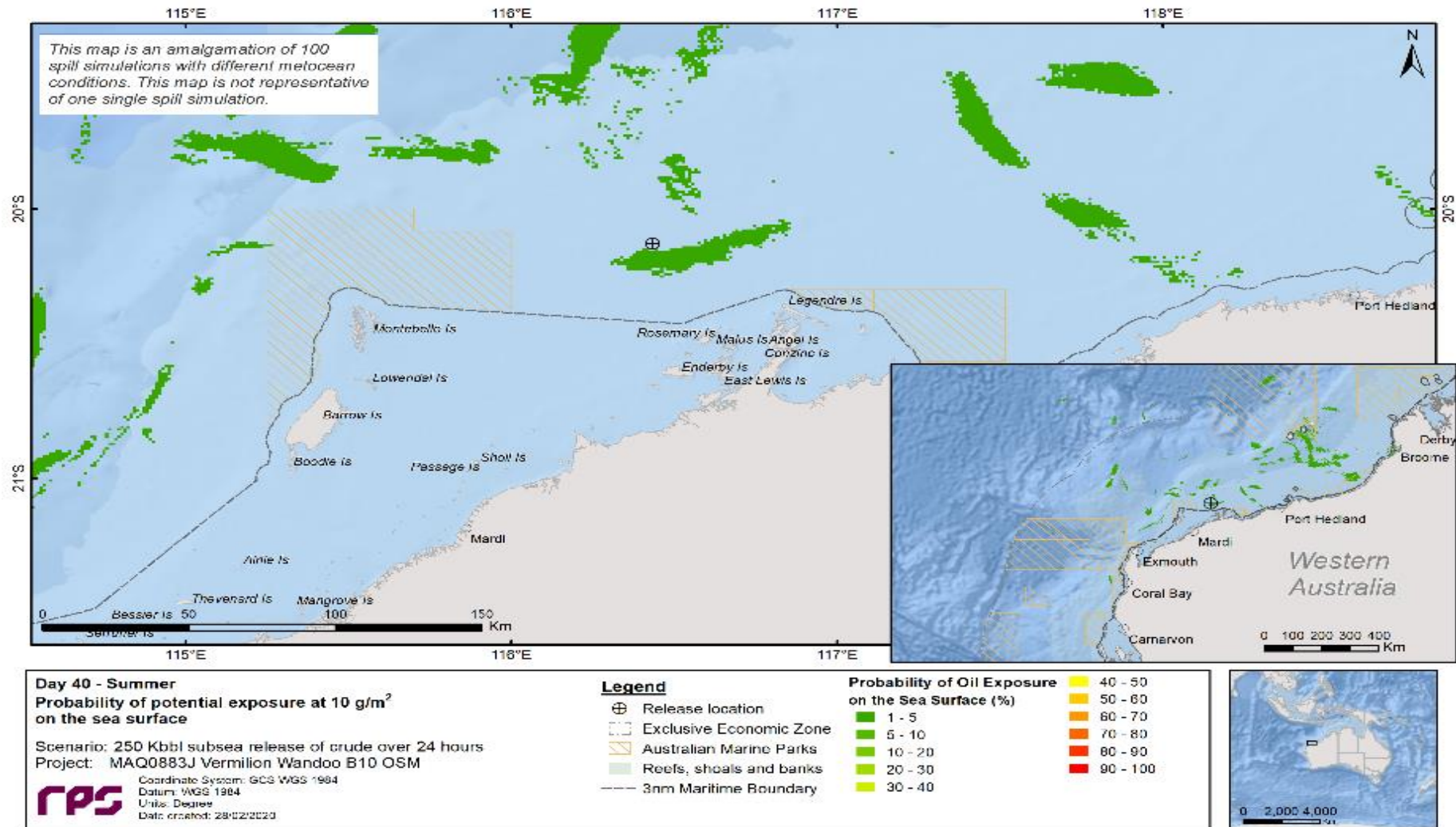

Figure 3-7 Probability of sea-surface exposure (above 10 g/m²) at day 40 during summer conditions

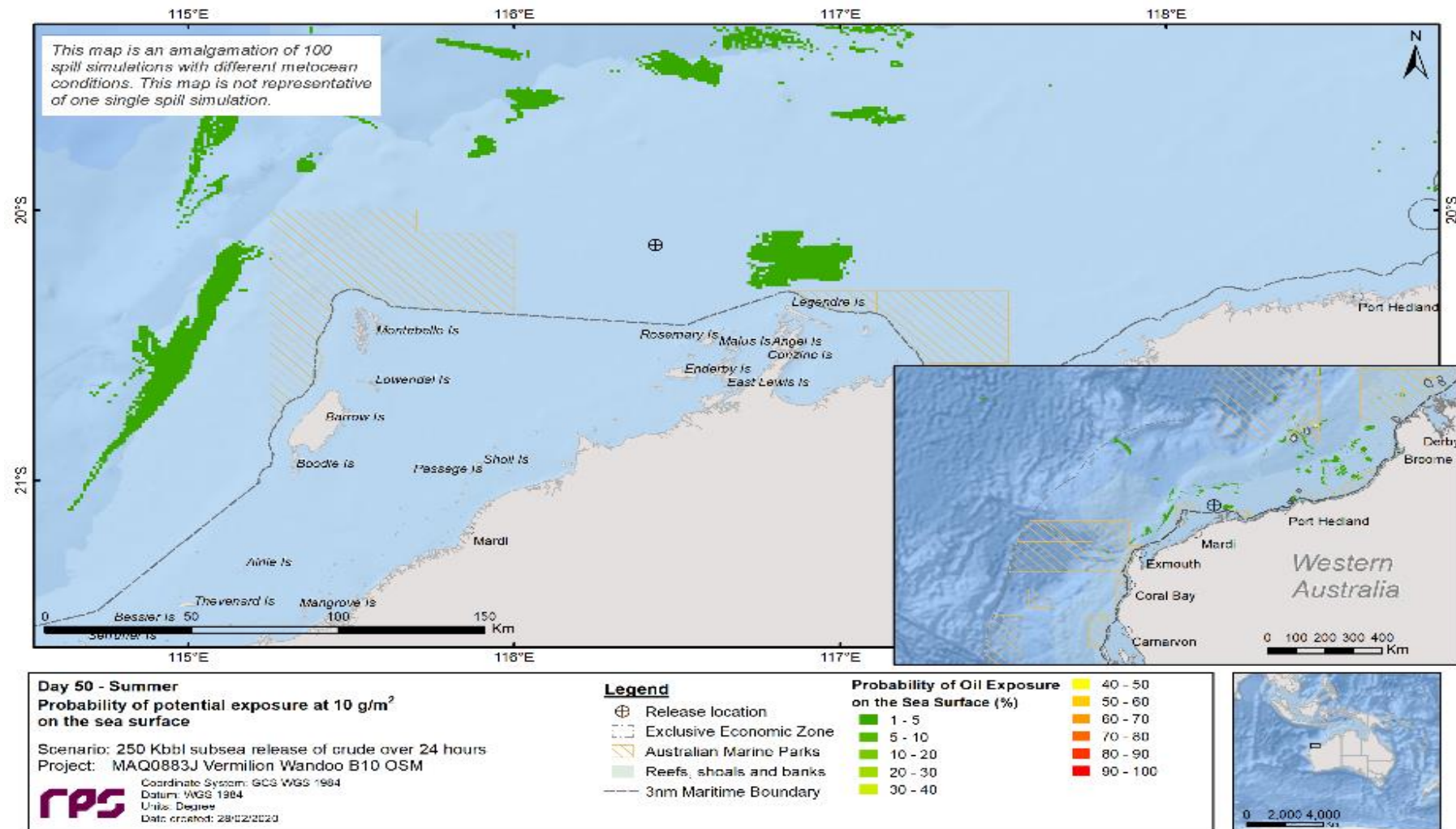

Figure 3-8 Probability of sea-surface exposure (above 10 g/m²) at day 50 during summer conditions

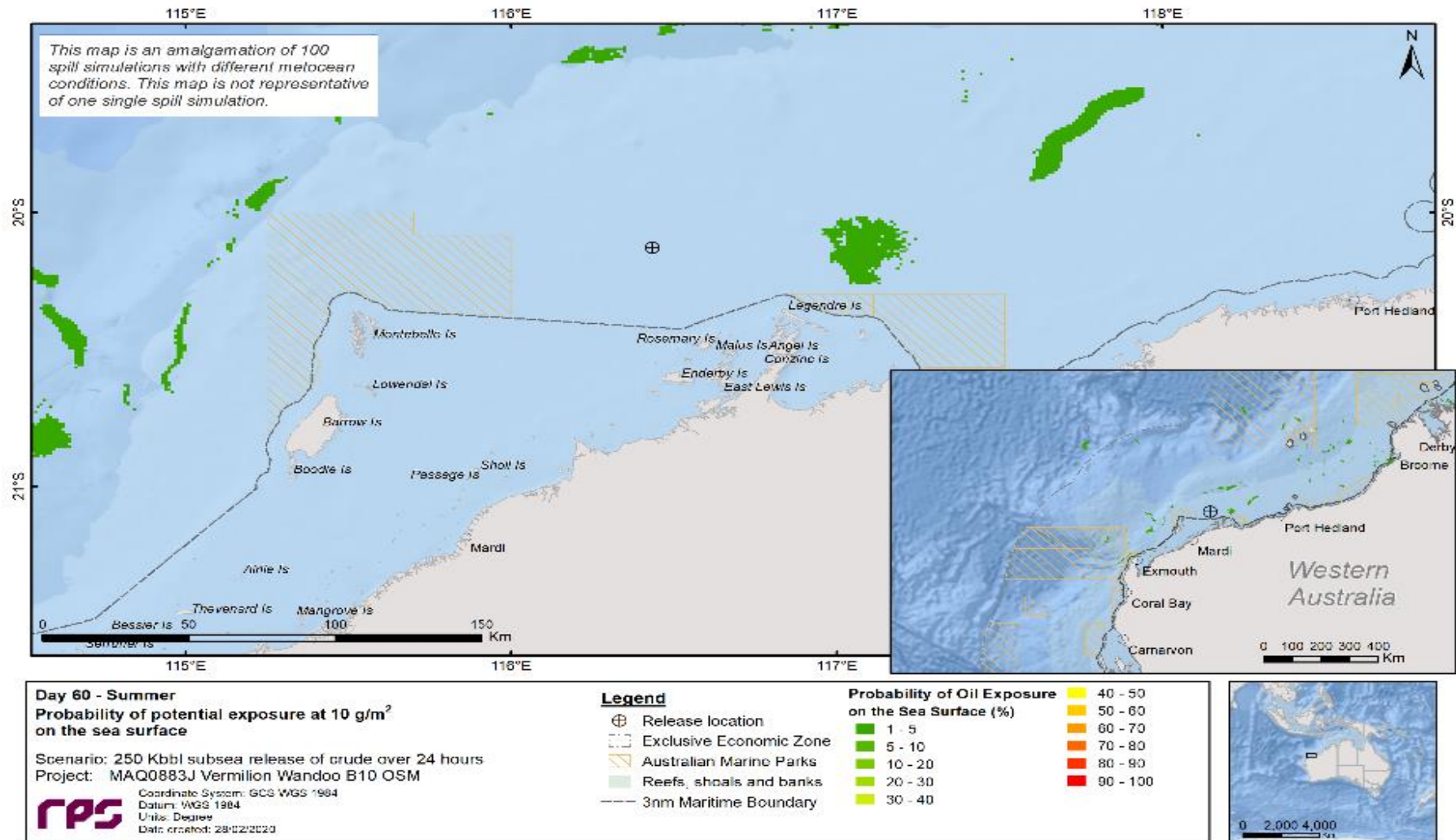

Figure 3-9 Probability of sea-surface exposure (above 10 g/m²) at day 60 during summer conditions

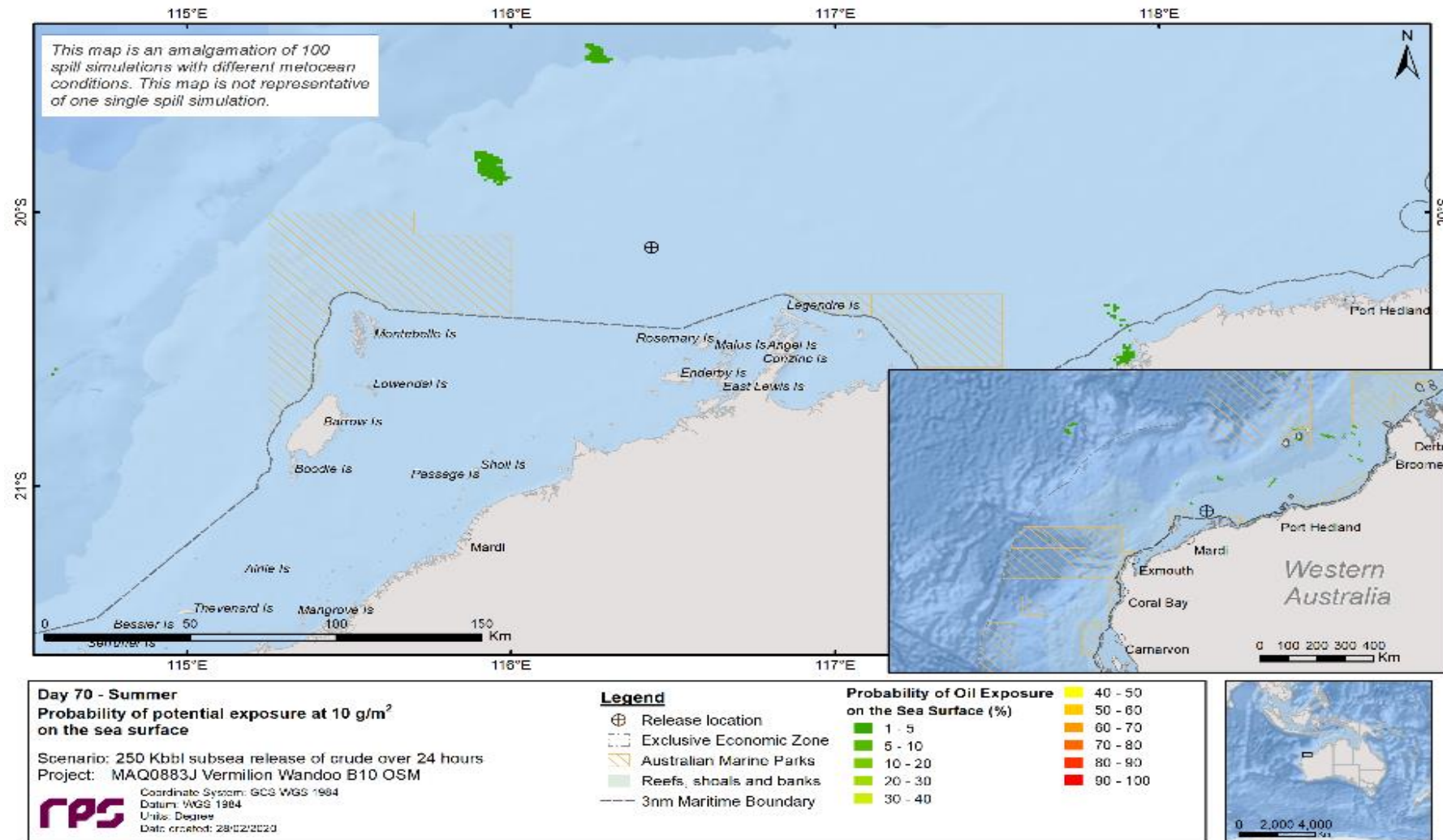

Figure 3-10 Probability of sea-surface exposure (above 10 g/m²) at day 70 during summer conditions

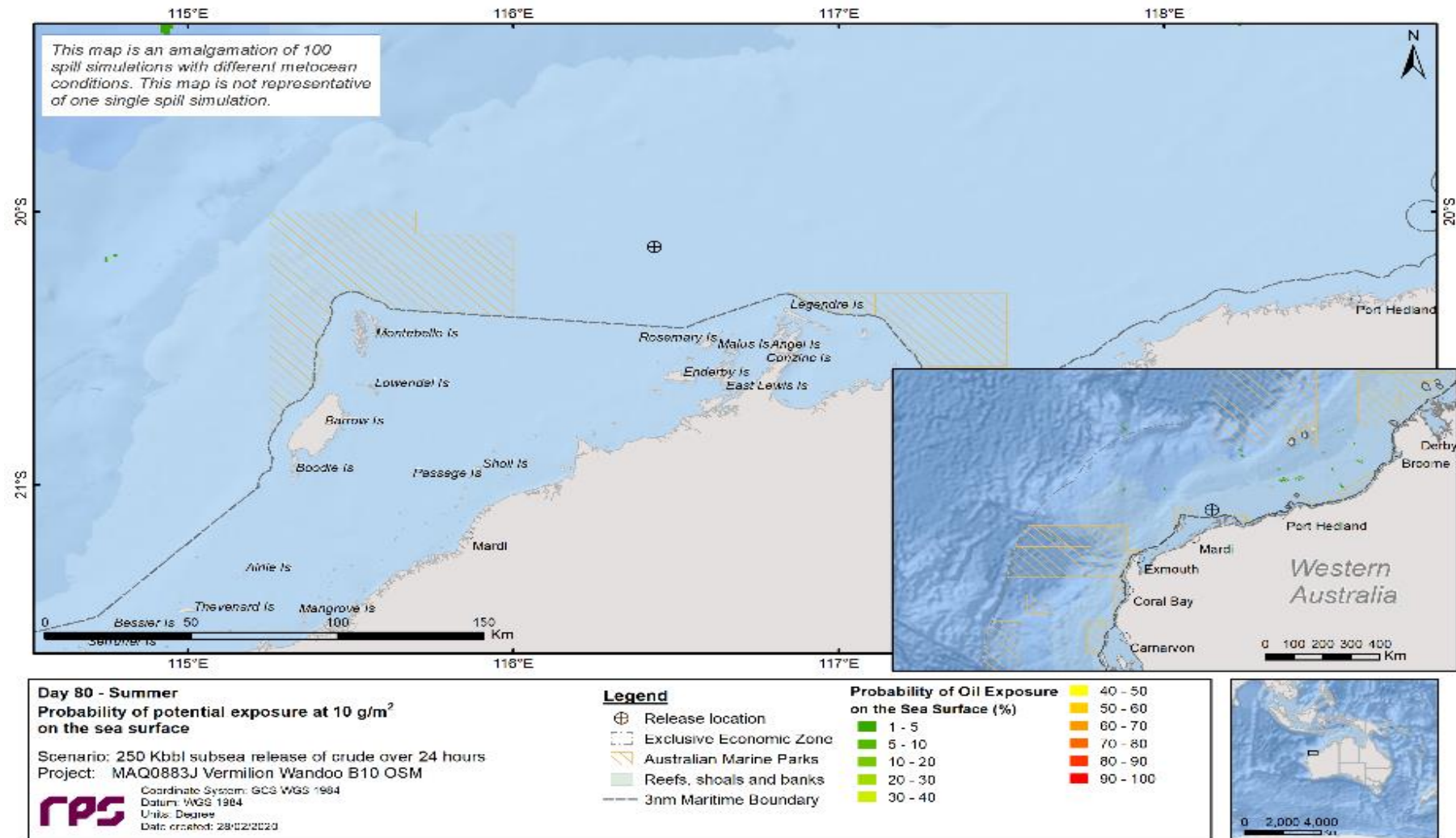

Figure 3-11 Probability of sea-surface exposure (above 10 g/m²) at day 80 during summer conditions

3.2 Shoreline Exposure

Table 3.5 presents a summary of the predicted shoreline contact across all seasons. The probability of contact to any shoreline at, or above, the low threshold (10 g/m²) during the summer, transitional and winter seasons was 86%, 37% and 60%, respectively.

The minimum time before shoreline contact was approximately 3.54 days (85 hours), 3.75 days (90 hours) and 2.54 days (61 hours) for the summer, transitional and winter seasons, respectively.

The greatest volume of oil predicted to come ashore from a spill trajectory was 16,791 m³ for a spill commencing in the summer period. While, the maximum length of shoreline contact at or above the moderate threshold (or actionable threshold) was 553 km in summer.

Table 3-5 Summary of oil contact to any shorelines. Results are based on a 250,000 bbl subsea release of Wandoo crude over 24 hours, tracked for 80 days during all seasonal conditions

Shoreline Statistics	Summer	Transitional	Winter
Probability of contact to any shoreline at, or above 10 g/m ² (%)	86	37	60
Absolute minimum time before shoreline contact at, or above 10 g/m ² (days)	3.54	3.75	2.54
Maximum volume of oil ashore (m ³)	16,791	9,687	8,691
Average volume of oil ashore (m ³)	4,197	1,059	573
Maximum length of shoreline contact at or above 10 g/m ² (km)	724	148	127
Average length of shoreline contact at or above 10 g/m ² (km)	275	33	21
Maximum length of shoreline contact at or above 100 g/m ² (km)	553	128	110
Average length of shoreline contact at or above 100 g/m ² (km)	215	27	19
Maximum length of shoreline contact at or above 1,000 g/m ² (km)	259	80	74
Average length of shoreline contact at or above 1,000 g/m ² (km)	91	33	15

Tables 3.6 to Table 3.8 summarise the oil contact to assessed shorelines for each season.

Under summer conditions, the highest probabilities of shoreline contact above the low threshold were predicted at Broome (43%), Imperieuse Reef (35%), Cunningham Island (32%), Clerke Reef (28%) and Mermaid Reef (26%), while the earliest shoreline contact was recorded on Montebello Islands (3.54 days).

In transitional months, the greatest probabilities of low shoreline contact were recorded at Montebello Islands (20%), Barrow Island (16%), Exmouth (14%), Middle Island (11%) and Boodie Island (9%). Montebello Islands recorded the earliest shoreline contact (3.75 days).

During winter, the greatest probabilities of low shoreline contact were recorded at Montebello Islands (26%), Christmas Island (24%), Barrow Island (11%), Lowendal Island (10%) and Cunningham Island (9%). Additionally, Montebello Islands registered the earliest shoreline contact (2.54 days).

Table 3-6 Summary of oil contact to assessed shorelines. Results are based on a 250,000 bbl subsea release of Wandoo crude over 24 hours, tracked for 80 days during summer conditions.

Shoreline receptor	Maximum probability of shoreline loading (%)			Minimum time before shoreline accumulation (days)			Load on shoreline (g/m ²)		Volume on shoreline (m ³)		Mean length of shoreline contact (km)			Maximum length of shoreline contact (km)		
	Low	Mod.	High	Low	Mod.	High	Mean	Peak	Mean	Peak	Low	Mod.	High	Low	Mod.	High
Adele Island	8	6	2	49.71	50.96	70.04	781	4,841	2	132	2	2	3	3	3	3
Airlie Island	5	4	3	6.54	6.67	7.25	6,741	13,879	5	163	1	1	1	1	1	1
Angel Island	11	8	3	8.38	8.54	9.00	1,413	25,167	20	1,359	6	6	5	10	9	7
Ashburton	6	6	3	8.42	9.08	9.92	221	8,661	14	875	50	30	9	122	86	25
Ashburton Island	4	4	2	7.83	9.04	9.83	768	2,662	1	46	2	2	2	2	2	2
Ashmore Reef	4	4	1	70.04	77.63	78.75	308	2,167	1	38	3	2	1	4	4	1
Barrow Island	11	11	5	5.29	5.71	6.13	1,990	24,986	218	7,984	39	32	34	84	83	68
Bedout Island	21	21	15	12.83	12.88	13.92	6,653	25,267	19	298	1	1	1	1	1	1
Bessieres Island	6	5	1	7.46	7.88	21.88	865	9,142	3	212	3	3	3	4	4	3
Bedout Island	11	10	7	10.58	10.92	13.96	3,260	15,538	5	183	1	1	1	1	1	1
Boodie Island	8	8	5	5.67	6.08	6.38	6,975	25,135	23	732	3	2	3	3	3	3
Broome	43	41	35	15.29	16.33	18.04	1,224	25,427	1,873	10,722	244	209	94	541	454	237
Browse Island	2	2	-	68.83	69.17	-	208	230	<1	3	1	1	-	1	1	-
Cape Bruguieres	12	12	4	8.00	8.25	8.54	2,062	25,148	16	817	3	3	4	5	5	5
Carnarvon	1	-	-	38.71	-	-	44	44	<1	1	1	-	-	1	-	-
Cartier Island	1	1	-	79.33	79.63	-	167	250	<1	6	3	3	-	3	3	-
Christmas Island	2	2	-	61.13	62.13	-	128	353	<1	37	12	7	-	21	12	-
Clerke Reef	28	27	19	30.71	30.83	31.25	2,914	24,637	44	691	4	3	4	4	4	4
Cohen Island	14	14	9	7.21	7.67	8.21	5,147	25,133	10	297	1	1	1	1	1	1
Conzinc Island	7	2	1	8.29	8.46	9.46	323	1,557	<1	18	1	1	1	1	1	1
Cunningham Island	32	32	24	26.71	26.71	26.96	4,002	18,096	52	539	3	3	3	3	3	3
Delambre Island	14	14	6	9.00	9.08	9.46	2,112	25,093	16	438	3	3	3	4	4	4
Derby - West Kimberly	14	14	7	50.04	51.67	52.50	718	25,400	140	5,414	54	42	29	277	228	79
Direction Island	4	4	3	7.71	8.21	9.79	5,141	18,789	6	426	2	2	2	2	2	2
Dolphin Island	9	6	3	8.33	8.50	9.25	263	7,388	3	150	6	5	2	20	15	3
Eaglehawk Island	6	6	3	3.79	3.83	4.25	3,903	16,884	3	199	1	1	1	1	1	1
East Lewis Island	4	2	1	7.92	9.38	9.50	506	4,786	2	160	3	5	3	8	8	3
East Pilbara	19	19	13	15.29	16.25	23.33	1,581	25,302	318	7,530	56	47	30	84	83	75
Enderby Island	12	9	4	3.71	3.79	3.96	680	19,358	29	1,993	13	12	9	29	28	25
Exmouth	12	9	3	12.54	12.79	30.92	250	9,828	41	2,649	35	34	26	194	168	65
Flat Island	5	5	2	7.75	8.17	21.17	1,133	6,117	2	151	3	2	2	3	3	3
Fly Island	3	2	-	12.38	21.83	0.00	342	820	<1	16	2	2	-	2	2	-
Gidley Island	10	10	4	7.96	8.17	8.88	1,963	25,167	28	1,791	7	6	5	11	11	10
Goodwyn Island	11	8	4	3.79	4.33	4.54	5,465	24,920	8	294	1	1	1	1	1	1
Haury Island	14	14	6	8.63	8.83	8.96	1,427	5018	3	59	1	1	1	1	1	1
Imperieuse Reef	35	34	22	26.83	26.92	27.08	3,356	24,505	80	843	5	5	5	5	5	5
Indonesia - Bali	6	5	-	66.13	66.29	-	104	490	1	47	15	9	-	37	15	-

Shoreline receptor	Maximum probability of shoreline loading (%)			Minimum time before shoreline accumulation (days)			Load on shoreline (g/m ²)		Volume on shoreline (m ³)		Mean length of shoreline contact (km)			Maximum length of shoreline contact (km)		
	Low	Mod.	High	Low	Mod.	High	Mean	Peak	Mean	Peak	Low	Mod.	High	Low	Mod.	High
Indonesia - Java	5	3	-	71.13	73.21	-	80	559	1	33	12	6	-	22	10	-
Indonesia - Kupang	1	-	-	76.96	0.00	-	29	29	<1	1	2	-	-	2	-	-
Indonesia - Lombok	6	6	1	58.58	58.88	68.75	115	1,052	3	172	21	11	1	70	47	1
Indonesia - Pulau Banta	1	1	-	74.25	74.42	-	109	149	<1	8	6	4	-	6	4	-
Indonesia - Pulau Dana	1	1	-	76.33	76.92	-	133	256	<1	5	3	1	-	3	1	-
Indonesia - Pulau Ende	1	-	-	78.92	-	-	86	86	<1	1	1	-	-	1	-	-
Indonesia - Pulau Flores	6	5	2	62.21	62.63	64.46	221	3,712	23	966	75	63	14	179	139	15
Indonesia - Pulau Kawula	3	1	-	71.58	71.83	-	62	121	<1	2	2	1	-	3	1	-
Indonesia - Pulau Keriwatu	2	-	-	77.75	-	-	42	56	<1	1	2	-	-	2	-	-
Indonesia - Pulau Komodo	5	5	2	58.21	58.25	64.08	231	3,275	5	167	23	15	2	39	28	2
Indonesia - Pulau Mules	4	4	2	62.00	62.13	64.21	688	2,543	3	128	7	6	5	9	7	5
Indonesia - Pulau Padar	2	2	-	63.92	65.42	-	169	265	<1	6	3	2	-	3	2	-
Indonesia - Pulau Rinca	4	3	2	62.96	63.75	64.21	288	1,646	2	84	11	10	3	18	14	3
Indonesia - Pulau Rote	2	1	-	76.67	78.00	-	95	194	<1	8	3	4	-	5	4	-
Indonesia - Pulau Rusa	1	-	-	78.71	-	-	43	57	<1	1	2	-	-	2	-	-
Indonesia - Pulau Sawu	2	2	-	72.63	78.17	-	88	278	<1	31	16	8	-	26	13	-
Indonesia - Pulau Semau	1	0	-	73.08	-	-	39	88	<1	3	6	-	-	6	-	-
Indonesia - Sumba Barat	7	5	2	56.46	56.67	61.33	139	1,335	6	206	33	27	3	72	45	3
Indonesia - Sumba Timur	8	8	-	61.83	62.33	-	100	769	2	56	21	8	-	56	25	-
Indonesia - Sumbawa	8	6	3	54.17	54.25	55.04	163	3,144	39	1,108	151	124	14	331	236	17
Karratha	18	16	10	3.83	4.29	4.83	489	18,849	143	4,386	68	49	22	202	178	78
Keast Island	14	13	6	7.42	7.50	8.33	5,028	25,146	10	297	1	1	1	1	1	1
Kendrew Island	17	15	8	3.79	4.21	4.46	8,046	25,174	19	297	1	1	1	1	1	1
King Leopold Ranges	4	4	-	57.96	58.63	-	206	906	1	51	6	4	-	10	7	-
Kingfisher Islands	4	4	2	55.63	57.63	59.13	2,569	17,839	27	1,308	10	10	16	20	19	16
Lacepede Islands	17	16	10	39.63	40.00	44.08	714	11,352	24	592	12	11	6	16	16	12
Legendre Island	16	16	11	6.92	6.96	7.04	2,479	25,194	84	3,066	13	12	8	16	16	16
Little Turtle Islet	19	19	15	11.04	16.79	17.25	8,714	25,359	45	598	2	2	2	2	2	2
Locker Island	4	3	1	8.75	8.79	9.58	594	1,345	<1	16	1	1	1	1	1	1
Lowendal Island	10	9	5	5.96	6.71	10.21	903	13,848	9	411	5	5	3	8	8	6
Malus Island	14	11	5	5.13	5.21	8.04	2,110	25,159	20	807	4	4	4	5	5	5
Mangrove Islands	5	5	3	9.79	10.08	10.38	1,917	9,884	8	368	6	5	5	6	6	6
Mary Anne Group	7	6	3	8.21	8.42	10.38	3,275	25,046	39	1,910	8	9	13	13	13	13
Mermaid Reef	26	25	15	32.33	32.63	33.08	2,107	25,362	22	677	3	3	2	3	3	3
Middle Island	10	8	5	5.67	5.71	6.21	3,974	25,237	22	779	3	3	3	4	4	4
Montebello Islands	16	15	8	3.54	3.67	4.42	1,801	25,158	151	7,983	25	22	20	41	41	41
Muiron Islands	7	7	2	8.08	12.17	31.46	399	1,688	3	123	8	6	5	9	9	7
North Turtle Island	19	18	14	11.00	11.04	17.54	7,352	25,293	19	299	1	1	1	1	1	1

Shoreline receptor	Maximum probability of shoreline loading (%)			Minimum time before shoreline accumulation (days)			Load on shoreline (g/m ²)		Volume on shoreline (m ³)		Mean length of shoreline contact (km)			Maximum length of shoreline contact (km)		
	Low	Mod.	High	Low	Mod.	High	Mean	Peak	Mean	Peak	Low	Mod.	High	Low	Mod.	High
Observation Island	3	3	2	7.75	8.38	21.63	776	1,928	1	53	3	2	2	3	3	3
Passage Islands	11	9	5	9.88	9.92	10.38	1,257	21,390	46	1,561	17	18	11	31	31	23
Peak Island	6	4	2	8.17	8.67	22.13	569	1,155	<1	14	1	1	1	1	1	1
Port Hedland	24	22	17	13.21	15.21	16.75	808	24,546	470	9,109	136	114	50	306	280	155
Pulau Lahalura	2	1	-	70.96	72.46	-	159	469	<1	13	4	3	-	4	3	-
Pulau Mangudu	1	1	-	71.50	74.21	-	73	117	<1	2	2	1	-	2	1	-
Pulau Ndana	2	-	-	70.96	-	-	43	83	<1	1	3	-	-	3	-	-
Ragnard Islands	10	7	2	3.71	3.75	4.29	548	4,102	1	50	2	2	2	2	2	2
Rivoli Islands	2	2	1	21.54	22.21	37.79	415	1,697	1	104	9	7	3	13	11	3
Rosemary Island	16	15	8	4.67	4.75	5.25	2,936	25,170	108	3,578	12	10	8	18	18	16
Round Island	5	4	1	7.67	9.25	21.96	672	2,735	<1	32	1	1	1	1	1	1
Sandy Islet	11	10	1	58.04	58.17	65.88	397	3,323	2	64	3	2	3	3	3	3
Serrurier Island	6	6	1	8.25	8.92	21.92	440	3,393	1	86	4	3	3	4	4	3
Sunday Island	5	4	-	6.75	12.79	-	222	744	1	23	3	3	-	4	4	-
Table Island	5	3	1	8.83	12.79	22.67	327	1,088	<1	13	1	1	1	1	1	1
Thevenard Island	5	4	2	7.13	7.29	7.71	2,518	9,323	9	355	4	5	5	5	5	5
Tortoise Island	6	5	2	8.25	8.58	9.33	856	2,502	1	29	1	1	1	1	1	1
Twin Island	3	3	2	8.13	8.21	9.54	3,478	9,060	3	199	2	2	2	2	2	2
West Lewis Island	11	9	3	4.83	4.92	8.08	474	10,815	12	809	8	6	6	23	23	13
Wyndham - East Kimberley	6	6	2	57.58	57.58	59.29	297	6310	12	684	30	22	10	73	58	17

Table 3-7 Summary of oil contact to assessed shorelines. Results are based on a 250,000 bbl subsea release of Wandoo crude over 24 hours, tracked for 80 days during transitional conditions.

Shoreline receptor	Maximum probability of shoreline loading (%)			Minimum time before shoreline accumulation (days)			Load on shoreline (g/m ²)		Volume on shoreline (m ³)		Mean length of shoreline contact (km)			Maximum length of shoreline contact (km)		
	Low	Mod.	High	Low	Mod.	High	Mean	Peak	Mean	Peak	Low	Mod.	High	Low	Mod.	High
Airlie Island	1	1	-	15.08	15.71	-	183	293	<1	4	2	1	-	2	1	-
Barrow Island	16	7	6	5.63	7.75	8.17	2,412	25,157	599	6841	20	35	32	53	51	47
Bessieres Island	3	2	-	12.63	12.79	-	211	416	<1	5	1	1	-	1	1	-
Boodie Island	9	7	5	8.08	8.17	10.92	1,955	11,001	16	275	3	2	2	3	3	3
Clerke Reef	2	2	2	68.29	68.42	68.63	2,273	4,180	6	151	4	4	4	4	4	4
Cunningham Island	2	2	2	70.00	70.83	72.17	6,149	12,208	15	408	4	4	4	4	4	4
Dandaragan	1	-	-	68.13	-	-	33	34	<1	1	2	-	-	2	-	-
Dorre Island	1	1	-	79.88	79.92	-	72	115	<1	2	2	1	-	2	1	-
Exmouth	14	11	1	11.67	12.04	12.67	266	18,133	104	3565	22	16	66	129	112	66
Flat Island	8	8	1	6.67	6.71	16.92	339	1,088	2	17	2	2	1	2	2	1
Imperieuse Reef	2	2	2	33.00	70.96	72.33	5,489	9,954	18	471	6	5	5	6	5	5
Lowendal Island	9	6	4	8.54	10.33	10.83	1,458	25,103	29	595	4	4	3	8	6	5
Mermaid Reef	3	3	2	62.54	62.75	67.29	6,933	19,017	13	395	2	2	2	2	2	2
Middle Island	11	7	5	8.08	8.17	10.88	1,135	11,001	23	304	4	4	4	6	6	6
Montebello Islands	20	15	10	3.75	3.92	4.63	1,465	25,111	240	2182	17	18	15	31	31	26
Murion Islands	8	7	2	7.88	9.71	11.17	749	6,970	18	502	8	7	6	10	10	10
North Island	1	1	-	58.38	66.42	-	76	114	<1	2	2	1	-	2	1	-
Northhampton	1	1	-	63.63	65.75	-	67	136	<1	3	5	1	-	5	1	-
Observation Island	1	1	-	15.75	16.67	-	230	230	<1	3	1	1	-	1	1	-
Peak Island	9	5	2	7.08	7.13	7.33	541	2,130	3	41	2	2	2	2	2	2
Rivoli Islands	1	-	-	13.42	-	-	40	62	<1	1	2	-	-	2	-	-
Rosemary Island	1	-	-	16.25	-	-	68	68	<1	1	1	-	-	1	-	-
Round Island	3	1	-	15.38	15.92	-	132	318	<1	7	2	2	-	2	2	-
Serrurier Island	5	4	-	12.67	12.83	-	128	229	<1	3	1	1	-	2	1	-
Shark Bay	1	-	-	65.83	-	-	49	69	<1	1	2	-	-	2	-	-
Sunday Island	7	3	1	14.63	14.71	16.29	295	1,701	1	38	1	1	2	2	2	2
Table Island	3	1	-	13.83	15.92	-	164	414	<1	5	1	1	-	1	1	-

Table 3-8 Summary of oil contact to assessed shorelines. Results are based on a 250,000 bbl subsea release of Wandoo crude over 24 hours, tracked for 80 days during winter conditions.

Shoreline receptor	Maximum probability of shoreline loading (%)			Minimum time before shoreline accumulation (days)			Load on shoreline (g/m ²)		Volume on shoreline (m ³)		Mean length of shoreline contact (km)			Maximum length of shoreline contact (km)		
	Low	Mod.	High	Low	Mod.	High	Mean	Peak	Mean	Peak	Low	Mod.	High	Low	Mod.	High
Airlie Island	1	1	-	10.96	11.92	-	253	426	<1	6	2	1	-	2	1	-
Ashburton	1	-	-	15.88	-	-	68	68	<1	1	1	-	-	1	-	-
Barrow Island	11	4	2	4.17	4.58	4.96	291	18,782	34	1,620	13	28	20	74	62	27
Bessieres Island	3	3	2	8.92	9.33	9.88	2,386	3,769	1	44	1	1	1	1	1	1
Boodie Island	4	3	2	5.54	5.54	5.96	1,776	12,515	4	195	2	2	3	3	3	3
Carnarvon	1	-	-	47.04	-	-	43	43	<1	1	2	-	-	2	-	-
Christmas Island	24	21	6	56.04	56.08	64.50	401	3,808	35	476	14	12	9	25	23	17
Clerke Reef	4	4	3	23.38	23.38	23.96	3,491	21,476	11	442	4	4	3	4	4	4
Cocos Islands	2	2	-	71.88	72.13	-	208	847	1	39	11	7	-	11	8	-
Cunningham Island	9	8	2	23.67	23.79	24.58	3,631	25,253	25	912	3	3	4	4	4	4
Dirk Hartog Island	1	-	-	47.58	-	-	64	85	<1	1	2	-	-	2	-	-
Exmouth	5	3	-	14.58	16.83	-	101	379	1	34	7	6	-	21	10	-
Flat Island	3	3	1	9.38	9.42	12.38	2,462	7,296	3	153	2	2	2	2	2	2
Fly Island	2	2	1	14.75	14.96	16.17	642	1,527	<1	27	2	2	1	2	2	1
Greater Geraldton	1	-	-	77.17	-	-	60	60	<1	1	1	-	-	1	0	-
Imperieuse Reef	9	8	2	23.67	23.79	24.54	3,072	24,020	32	975	5	4	6	6	6	6
Indonesia - Java	1	1	-	74.88	78.96	-	75	116	<1	4	5	2	-	5	2	-
Lowendal Island	10	8	2	4.50	4.50	4.54	2,303	24,978	35	1,962	5	4	7	8	8	8
Mary Anne Group	1	-	-	13.00	-	-	49	73	<1	2	4	-	-	4	-	-
Mermaid Reef	2	2	2	27.92	31.00	31.13	1,893	2,787	2	76	3	3	3	3	3	3
Middle Island	5	4	2	5.00	5.46	5.46	1,390	12,515	8	418	4	4	4	6	6	5
Montebello Islands	26	22	16	2.54	2.63	2.79	2,606	25,122	365	7,584	18	18	12	31	31	31
Murion Islands	5	3	3	8.67	8.88	9.04	1,413	7,395	13	505	7	9	6	10	10	10
Observation Island	2	2	1	13.67	14.42	15.75	1,243	1,895	<1	22	1	1	1	1	1	1
Passage Islands	1	-	-	15.00	-	-	39	39	-	-	1	-	-	1	-	-
Peak Island	4	3	3	8.46	8.50	8.83	9,364	25,077	15	584	2	2	2	2	2	2
Rivoli Islands	2	1	1	14.58	14.96	16.42	230	1,129	1	57	8	10	1	12	10	1
Round Island	1	1	1	11.63	11.71	12.04	1,824	2,469	1	42	2	2	2	2	2	2
Serrurier Island	1	1	1	11.33	11.54	11.96	3,518	4,726	2	122	3	3	3	3	3	3
Sunday Island	3	3	3	8.88	8.88	8.96	5,050	6,465	6	147	2	2	2	2	2	2
Table Island	2	1	1	9.83	11.54	12.00	1,143	2,242	<1	26	1	1	1	1	1	1
Thevenard Island	1	1	-	9.88	12.54	-	150	292	<1	5	3	2	-	3	2	-

3.3 In Water Exposure

3.3.1 Dissolved Hydrocarbons

Tables 3.9 to Table 3.17 summarise the probability of exposure to receptors from instantaneous dissolved hydrocarbons in the 0-10 m, 10-20 m and 20-30 m depth layers, across all seasonal conditions, at the low (10-50 ppb), moderate (50-400 ppb) and high (≥ 400 ppb) thresholds.

In the surface (0-10 m) depth layer, the greatest probabilities of low dissolved hydrocarbon exposure across all seasons was predicted at the Northwest Shelf IMCRA (72% - summer; 43% - transitional; 48% - winter), Montebello AMP (15% - summer; 69% - transitional; 66% - winter), Tryal Rock RSB (5% - summer; 47% - transitional; 47% - winter) and Continental slope demersal fish communities KEF (14% - summer; 37% - transitional; 24% - winter).

In the 10-20 m depth layer, the greatest probabilities of low dissolved hydrocarbon exposure across all seasons was predicted at the Northwest Shelf IMCRA (37% - summer; 26% - transitional; 22% - winter), Montebello AMP (11% - summer; 39% - transitional; 37% - winter), Ancient coastline at 125 m depth contour KEF (23% - summer; 15% - transitional; 15% - winter) and Continental slope demersal fish communities (11% - summer; 18% - transitional; 14% - winter).

In the 20-30 m depth layer, the greatest probabilities of low dissolved hydrocarbon exposure across all seasons was predicted at the Northwest Shelf IMCRA (15% - summer; 11% - transitional; 9% - winter) and Montebello AMP (0% - summer; 11% - transitional; 13% - winter).

Table 3-9 Probability of exposure to individual receptors from instantaneous dissolved hydrocarbons in the 0-10 m depth layer. Results are based on a 250,000 bbl subsea release of Wandoo crude over 24 hours, tracked for 80 days during summer conditions.

0-10 m depth layer		Maximum dissolved hydrocarbon exposure (ppb)	Probability of hydrocarbon exposure		
Receptor	Low		Moderate	High	
AMP	Abrolhos	27	1	-	-
	Argo-Rowley Terrace	50	3	-	-
	Carnarvon Canyon	18	1	-	-
	Dampier	105	4	1	-
	Eighty Mile Beach	18	2	-	-
	Gascoyne	209	5	2	-
	Montebello	197	15	5	-
	Ningaloo	28	2	-	-
	Shark Bay	14	1	-	-
CP	Montebello Islands	59	3	1	-
IBRA	Cape Range	115	4	2	-
	Chichester	10	1	-	-
	Roebourne	86	4	1	-
IMCRA	Ningaloo	19	2	-	-
	Northwest Shelf	424	72	19	1
	Pilbara (nearshore)	90	5	1	-
	Zuytdorp	46	2	-	-
KEF	Ancient coastline at 125 m depth contour	154	25	4	-
	Canyons linking the Cuvier Abyssal Plain and the Cape Range Peninsula	202	6	1	-
	Commonwealth waters adjacent to Ningaloo Reef	28	2	-	-
	Continental Slope Demersal Fish Communities	156	14	2	-
	Exmouth Plateau	101	6	1	-
	Glomar Shoals	233	27	7	-
	Western demersal slope and associated fish communities	17	1	-	-
MMA	Barrow Island	131	5	2	-
	Muiron Islands	14	1	-	-
MP	Barrow Island	103	3	1	-
	Montebello Islands	159	6	3	-
	Ningaloo	16	1	-	-
NR	Great Sandy Island	23	2	-	-
	Thevenard Island	21	1	-	-
RSB	Barrow Island Reefs and Shoals	30	3	-	-
	Eliassen Rocks	11	1	-	-

0-10 m depth layer		Maximum dissolved hydrocarbon exposure (ppb)	Probability of hydrocarbon exposure		
Receptor	Low		Moderate	High	
	Fortescue Reef	12	1	-	-
	Glomar Shoal	98	12	2	-
	Herald Reef	14	1	-	-
	Lightfoot Reef	27	2	-	-
	Locker Reef	18	1	-	-
	Madeleine Shoals	37	3	-	-
	Montebello Shoals	115	4	2	-
	Ningaloo Reef	13	1	-	-
	Paroo Shoal	12	1	-	-
	Rankin Bank	62	10	1	-
	Ripple Shoals	46	4	-	-
	South East Reef	12	1	-	-
	Tryal Rocks	29	5	-	-
	West Reef	11	2	-	-
State Waters	Western Australia	159	6	3	-

Table 3-10 Probability of exposure to individual receptors from instantaneous dissolved hydrocarbons in the 0-10 m depth layer. Results are based on a 250,000 bbl subsea release of Wandoo crude over 24 hours, tracked for 80 days during transitional conditions.

0-10 m depth layer		Maximum dissolved hydrocarbon exposure (ppb)	Probability of hydrocarbon exposure		
Receptor	Low		Moderate	High	
AMP	Abrolhos	49	1	-	-
	Carnarvon Canyon	36	2	-	-
	Gascoyne	230	16	3	-
	Montebello	428	69	20	1
	Ningaloo	141	13	2	-
	Shark Bay	25	2	-	-
CP	Montebello Islands	131	11	2	-
IBRA	Cape Range	133	13	2	-
	Roebourne	15	2	-	-
IMCRA	Ningaloo	131	13	2	-
	Northwest Shelf	278	43	13	-
	Pilbara (nearshore)	43	2	-	-
	Zuytdorp	38	3	-	-
KEF	Ancient coastline at 125 m depth contour	193	35	8	-
	Canyons linking the Cuvier Abyssal Plain and the Cape Range Peninsula	154	17	2	-

0-10 m depth layer		Maximum dissolved hydrocarbon exposure (ppb)	Probability of hydrocarbon exposure		
Receptor	Low		Moderate	High	
	Commonwealth waters adjacent to Ningaloo Reef	141	13	2	-
	Continental Slope Demersal Fish Communities	222	37	7	-
	Exmouth Plateau	104	9	1	-
	Glomar Shoals	109	9	3	-
	Wallaby Saddle	20	1	-	-
	Western demersal slope and associated fish communities	28	1	-	-
MMA	Barrow Island	67	8	1	-
	Muiron Islands	93	8	2	-
MP	Barrow Island	33	3	-	-
	Montebello Islands	134	24	5	-
	Ningaloo	68	6	1	-
RSB	Glomar Shoal	72	2	1	-
	Montebello Shoals	131	11	1	-
	Ningaloo Reef	22	1	-	-
	Outtrim Patches	80	4	1	-
	Rankin Bank	44	7	-	-
	Rosily Shoals	12	1	-	-
	Tryal Rocks	139	47	4	-
State Waters	Western Australia	184	24	5	-

Table 3-11 Probability of exposure to individual receptors from instantaneous dissolved hydrocarbons in the 0-10 m depth layer. Results are based on a 250,000 bbl subsea release of Wandoo crude over 24 hours, tracked for 80 days during winter conditions.

0-10 m depth layer		Maximum dissolved hydrocarbon exposure (ppb)	Probability of hydrocarbon exposure		
Receptor	Low		Moderate	High	
AMP	Argo-Rowley Terrace	14	1	-	-
	Carnarvon Canyon	16	1	-	-
	Gascoyne	114	8	1	-
	Montebello	490	66	18	1
	Ningaloo	95	4	1	-
CP	Montebello Islands	82	13	1	-
IBRA	Cape Range	153	16	1	-
	Roebourne	16	1	-	-
IMCRA	Ningaloo	95	7	1	-
	Northwest Shelf	362	48	14	-
	Pilbara (nearshore)	13	1	-	-

0-10 m depth layer		Maximum dissolved hydrocarbon exposure (ppb)	Probability of hydrocarbon exposure		
Receptor	Low		Moderate	High	
KEF	Ancient coastline at 125 m depth contour	254	29	4	-
	Canyons linking the Cuvier Abyssal Plain and the Cape Range Peninsula	114	14	2	-
	Commonwealth waters adjacent to Ningaloo Reef	95	4	1	-
	Continental Slope Demersal Fish Communities	187	24	3	-
	Exmouth Plateau	60	11	1	-
	Glomar Shoals	114	10	2	-
	MMA	Barrow Island	112	6	1
Muiron Islands		41	6	-	-
MP	Barrow Island	46	6	-	-
	Montebello Islands	123	35	7	-
	Ningaloo	71	2	1	-
RSB	Glomar Shoal	51	6	1	-
	Hood Reef	23	1	-	-
	Montebello Shoals	46	13	-	-
	Ningaloo Reef	44	1	-	-
	Outtrim Patches	23	1	-	-
	Rankin Bank	54	12	1	-
	Rosily Shoals	15	1	-	-
	Trap Reef	13	1	-	-
	Tryal Rocks	133	47	6	-
State Waters	Western Australia	183	36	7	-

Table 3-12 Probability of exposure to individual receptors from instantaneous dissolved hydrocarbons in the 10-20 m depth layer. Results are based on a 250,000 bbl subsea release of Wandoo crude over 24 hours, tracked for 80 days during summer conditions.

10-20 m depth layer		Maximum dissolved hydrocarbon exposure (ppb)	Probability of hydrocarbon exposure		
Receptor	Low		Moderate	High	
AMP	Argo-Rowley Terrace	45	2	-	-
	Carnarvon Canyon	34	1	-	-
	Dampier	59	4	1	-
	Eighty Mile Beach	24	3	-	-
	Gascoyne	130	4	1	-
	Montebello	163	11	3	-
	Ningaloo	47	2	-	-
CP	Montebello Islands	17	1	-	-
IBRA	Cape Range	131	2	1	-
	Roebourne	39	2	-	-
IMCRA	Ningaloo	38	2	-	-
	Northwest Shelf	304	37	7	-
	Pilbara (nearshore)	75	4	1	-
	Zuytdorp	20	1	-	-
KEF	Ancient coastline at 125 m depth contour	161	23	4	-
	Canyons linking the Cuvier Abyssal Plain and the Cape Range Peninsula	123	4	1	-
	Commonwealth waters adjacent to Ningaloo Reef	47	2	-	-
	Continental Slope Demersal Fish Communities	133	11	2	-
	Exmouth Plateau	135	3	1	-
	Glomar Shoals	200	20	4	-
	Western demersal slope and associated fish communities	23	1	-	-
MMA	Barrow Island	139	4	2	-
	Muiron Islands	13	1	-	-
MP	Barrow Island	45	2	-	-
	Montebello Islands	132	5	1	-
	Ningaloo	20	2	-	-
NR	Great Sandy Island	16	2	-	-
RSB	Barrow Island Reefs and Shoals	20	1	-	-
	Glomar Shoal	69	8	2	-
	Lightfoot Reef	14	1	-	-
	Madeleine Shoals	14	3	-	-
	Montebello Shoals	40	2	-	-
	Rankin Bank	76	10	1	-



APPENDIX 3

Oil Spill Trajectory Modelling

10-20 m depth layer		Maximum dissolved hydrocarbon exposure (ppb)	Probability of hydrocarbon exposure		
Receptor			Low	Moderate	High
	Ripple Shoals	18	2	-	-
	Tryal Rocks	34	3	-	-
State Waters	Western Australia	151	5	2	-

Table 3-13 Probability of exposure to individual receptors from instantaneous dissolved hydrocarbons in the 10-20 m depth layer. Results are based on a 250,000 bbl subsea release of Wandoo crude over 24 hours, tracked for 80 days during transitional conditions.

10-20 m depth layer		Maximum dissolved hydrocarbon exposure (ppb)	Probability of hydrocarbon exposure		
Receptor	Low		Moderate	High	
AMP	Abrolhos	64	1	1	-
	Carnarvon Canyon	11	1	-	-
	Gascoyne	233	8	2	-
	Montebello	337	39	8	-
	Ningaloo	273	5	1	-
	Shark Bay	11	1	-	-
CP	Montebello Islands	23	2	-	-
IBRA	Cape Range	90	4	1	-
IMCRA	Ningaloo	157	6	1	-
	Northwest Shelf	235	26	6	-
	Pilbara (nearshore)	21	1	-	-
	Zuytdorp	39	1	-	-
KEF	Ancient coastline at 125 m depth contour	164	15	3	-
	Canyons linking the Cuvier Abyssal Plain and the Cape Range Peninsula	153	11	2	-
	Commonwealth waters adjacent to Ningaloo Reef	273	5	1	-
	Continental Slope Demersal Fish Communities	273	18	3	-
	Exmouth Plateau	111	5	1	-
	Glomar Shoals	98	5	1	-
	Wallaby Saddle	28	1	-	-
	Western demersal slope and associated fish communities	29	1	-	-
MMA	Barrow Island	49	5	-	-
	Muiron Islands	93	4	1	-
MP	Barrow Island	16	4	-	-
	Montebello Islands	103	14	1	-
	Ningaloo	157	3	1	-
RSB	Glomar Shoal	16	1	-	-
	Montebello Shoals	23	2	-	-
	Ningaloo Reef	21	1	-	-
	Outtrim Patches	37	3	-	-
	Rankin Bank	18	2	-	-
	Tryal Rocks	113	19	1	-
State Waters	Western Australia	180	14	2	-

Table 3-14 Probability of exposure to individual receptors from instantaneous dissolved hydrocarbons in the 10-20 m depth layer. Results are based on a 250,000 bbl subsea release of Wandoo crude over 24 hours, tracked for 80 days during winter conditions.

10-20 m depth layer		Maximum dissolved hydrocarbon exposure (ppb)	Probability of hydrocarbon exposure		
Receptor	Low		Moderate	High	
AMP	Argo-Rowley Terrace	11	1	-	-
	Carnarvon Canyon	18	1	-	-
	Gascoyne	115	6	1	-
	Montebello	428	37	8	1
	Ningaloo	70	2	1	-
CP	Montebello Islands	16	3	-	-
IBRA	Cape Range	36	6	-	-
IMCRA	Ningaloo	70	5	1	-
	Northwest Shelf	258	22	5	-
	Pilbara (nearshore)	10	1	-	-
KEF	Ancient coastline at 125 m depth contour	220	15	2	-
	Canyons linking the Cuvier Abyssal Plain and the Cape Range Peninsula	71	7	1	-
	Commonwealth waters adjacent to Ningaloo Reef	70	2	1	-
	Continental Slope Demersal Fish Communities	175	14	3	-
	Exmouth Plateau	78	6	1	-
	Glomar Shoals	129	7	3	-
	Barrow Island	46	5	-	-
MMA	Muiron Islands	28	2	-	-
MP	Barrow Island	47	3	-	-
	Montebello Islands	125	17	3	-
	Ningaloo	45	1	-	-
RSB	Glomar Shoal	30	4	-	-
	Montebello Shoals	18	3	-	-
	Ningaloo Reef	21	1	-	-
	Rankin Bank	74	5	1	-
	Tryal Rocks	97	15	2	-
State Waters	Western Australia	125	17	3	-

Table 3-15 Probability of exposure to individual receptors from instantaneous dissolved hydrocarbons in the 20-30 m depth layer. Results are based on a 250,000 bbl subsea release of Wandoo crude over 24 hours, tracked for 80 days during summer conditions.

20-30 m depth layer		Maximum dissolved hydrocarbon exposure (ppb)	Probability of hydrocarbon exposure		
Receptor	Low		Moderate	High	
AMP	Argo-Rowley Terrace	31	2	-	-
	Carnarvon Canyon	18	1	-	-
	Dampier	38	2	-	-
	Eighty Mile Beach	24	1	-	-
	Gascoyne	55	3	1	-
	Montebello	125	5	1	-
	Ningaloo	27	2	-	-
IMCRA	Ningaloo	20	2	-	-
	Northwest Shelf	170	15	3	-
	Pilbara (nearshore)	27	2	-	-
	Zuytdorp	23	1	-	-
KEF	Ancient coastline at 125 m depth contour	77	7	1	-
	Canyons linking the Cuvier Abyssal Plain and the Cape Range Peninsula	78	3	1	-
	Commonwealth waters adjacent to Ningaloo Reef	27	2	-	-
	Continental Slope Demersal Fish Communities	103	5	1	-
	Exmouth Plateau	45	3	-	-
	Glomar Shoals	170	6	1	-
	Western demersal slope and associated fish communities	11	1	-	-
MMA	Barrow Island	13	1	-	-
MP	Montebello Islands	21	1	-	-
	Ningaloo	15	1	-	-
RSB	Glomar Shoal	36	3	-	-
	Penguin Bank	20	1	-	-
	Rankin Bank	20	3	-	-
State Waters	Western Australia	139	2	1	-

Table 3-16 Probability of exposure to individual receptors from instantaneous dissolved hydrocarbons in the 20-30 m depth layer. Results are based on a 250,000 bbl subsea release of Wandoo crude over 24 hours, tracked for 80 days during transitional conditions.

20-30 m depth layer		Maximum dissolved hydrocarbon exposure (ppb)	Probability of hydrocarbon exposure			
Receptor	Low		Moderate	High		
AMP	Abrolhos	27	1	-	-	
	Gascoyne	102	5	1	-	
	Montebello	208	11	3	-	
	Ningaloo	81	2	1	-	
IBRA	Cape Range	19	1	-	-	
IMCRA	Ningaloo	65	2	1	-	
	Northwest Shelf	140	11	3	-	
	Zuytdorp	23	1	-	-	
KEF	Ancient coastline at 125 m depth contour	74	9	2	-	
	Canyons linking the Cuvier Abyssal Plain and the Cape Range Peninsula	72	3	1	-	
	Commonwealth waters adjacent to Ningaloo Reef	81	2	1	-	
	Continental Slope Demersal Fish Communities	139	6	1	-	
	Exmouth Plateau	61	3	1	-	
	Glomar Shoals	26	2	-	-	
	Wallaby Saddle	17	1	-	-	
	Western demersal slope and associated fish communities	13	1	-	-	
	MMA	Barrow Island	34	1	-	-
	MP	Barrow Island	17	1	-	-
Montebello Islands		25	2	-	-	
Ningaloo		40	1	-	-	
RSB	Ningaloo Reef	15	1	-	-	
	Tryal Rocks	24	2	-	-	
State Waters	Western Australia	117	4	1	-	

Table 3-17 Probability of exposure to individual receptors from instantaneous dissolved hydrocarbons in the 20-30 m depth layer. Results are based on a 250,000 bbl subsea release of Wandoo crude over 24 hours, tracked for 80 days during winter conditions.

20-30 m depth layer		Maximum dissolved hydrocarbon exposure (ppb)	Probability of hydrocarbon exposure		
Receptor	Low		Moderate	High	
AMP	Gascoyne	50	3	1	-
	Montebello	260	13	2	-
IBRA	Cape Range	26	2	-	-
IMCRA	Ningaloo	29	3	-	-
	Northwest Shelf	237	9	2	-
KEF	Ancient coastline at 125 m depth contour	128	5	1	-
	Canyons linking the Cuvier Abyssal Plain and the Cape Range Peninsula	47	3	-	-
	Continental Slope Demersal Fish Communities	125	6	2	-
	Exmouth Plateau	46	3	-	-
	Glomar Shoals	111	5	1	-
MMA	Barrow Island	24	1	-	-
	Muiron Islands	26	1	-	-
MP	Barrow Island	26	1	-	-
	Montebello Islands	32	4	-	-
RSB	Glomar Shoal	40	2	-	-
	Montebello Shoals	15	1	-	-
	Rankin Bank	22	2	-	-
	Tryal Rocks	33	3	-	-
State Waters	Western Australia	80	5	1	-

3.3.2 *Entrained Hydrocarbons*

Table 3.18 to Table 3.26 summarise the probability of exposure to individual receptors from instantaneous entrained hydrocarbons in the 0-10 m, 10-20 m and 20-30 m depth layers across all seasonal conditions, at the low (10-100 ppb) and high (≥ 100 ppb) exposure thresholds.

In the surface (0-10 m) depth layer, the greatest probabilities of low entrained hydrocarbon exposure across all seasons was predicted at the Continental slope demersal fish communities KEF (74% - summer; 97% - transitional; 85% winter), Ancient coastline at 125 m depth contour KEF (77% - summer; 93% - transitional; 88% - winter) and Montebello AMP (55% - summer; 89% - transitional; 90% - winter).

In the 10-20 m depth layer, the greatest probabilities of low entrained hydrocarbon exposure across all seasons was predicted at the Northwest Shelf IMCRA (80% - summer; 43% - transitional; 43% - winter), Montebello AMP (38% - summer; 75% - transitional; 66% - winter) and Continental slope demersal fish communities KEF (47% - summer; 64% - transitional, 53% - winter).

In the 20-30 m depth layer, the greatest probabilities of low entrained hydrocarbon exposure across all seasons was predicted at the Montebello AMP (10% - summer; 28% - transitional; 20% - winter), Northwest Shelf IMCRA (27% - summer; 14% - transitional; 7% -winter) and Ancient coastline at 125 m depth contour KEF (12% - summer; 6% - transitional; 11% - winter).

Table 3-18 Probability of exposure to individual receptors from instantaneous entrained hydrocarbons in the 0-10 m depth layer. Results are based on a 250,000 bbl subsea release of Wandoo crude over 24 hours, tracked for 80 days during summer conditions.

0-10 m depth layer		Maximum entrained hydrocarbon exposure (ppb)	Probability of hydrocarbon exposure	
Receptor			Low	High
AMP	Abrolhos	242	6	1
	Argo-Rowley Terrace	801	27	9
	Carnarvon Canyon	142	12	1
	Dampier	4,419	15	11
	Eighty Mile Beach	1,528	17	12
	Gascoyne	2,492	38	13
	Kimberley	89	1	-
	Mermaid Reef	102	2	1
	Montebello	46,568	55	29
	Ningaloo	331	29	6
	Roebuck	69	1	-
	Shark Bay	168	10	1
CP	Montebello Islands	4,553	19	4
EEZ	Indonesian Exclusive Economic Zone	29	2	-
IBRA	Cape Range	10,112	21	6
	Chichester	106	5	1
	Pindanland	710	9	4
	Roebourne	6,480	15	10
	Wooramel	14	1	-
IMCRA	Canning	754	5	1
	Eighty Mile Beach	821	14	8
	Ningaloo	859	38	6
	Northwest Shelf	84,411	89	86
	Pilbara (nearshore)	13,833	17	12
	Zuytdorp	283	14	1
IPA	Nyangumarta Warrarn	698	7	3
KEF	Ancient coastline at 125 m depth contour	19,683	77	48
	Canyons linking the Argo Abyssal Plain with the Scott Plateau	14	1	-
	Canyons linking the Cuvier Abyssal Plain and the Cape Range Peninsula	2,817	44	14
	Commonwealth waters adjacent to Ningaloo Reef	331	29	6
	Continental Slope Demersal Fish Communities	14,823	74	33
	Exmouth Plateau	1,265	35	7
	Glomar Shoals	26,826	75	52



0-10 m depth layer		Maximum entrained hydrocarbon exposure (ppb)	Probability of hydrocarbon exposure	
Receptor	Low		High	
	Mermaid Reef and Commonwealth waters surrounding Rowley Shoals	272	9	2
	Wallaby Saddle	91	4	-
	Western demersal slope and associated fish communities	47	4	-
MMA	Barrow Island	15,060	22	7
	Muiron Islands	197	19	3
MP	Barrow Island	11,967	18	6
	Eighty Mile Beach	821	10	5
	Montebello Islands	20,401	32	12
	Ningaloo	176	20	3
	Rowley Shoals	97	9	-
	Yawuru Nagulagun / Roebuck Bay	18	1	-
NR	Great Sandy Island	1,013	6	4
	Thevenard Island	1,051	4	3
RAMSAR	Eighty-mile Beach	737	9	4
RSB	Barrow Island Reefs and Shoals	970	6	4
	Baylis Patches	109	2	1
	Beryl Reef	76	1	-
	Brewis Reef	223	4	3
	Clerke Reef	28	4	-
	Eliassen Rocks	86	3	-
	Exmouth Reef	73	1	-
	Fortescue Reef	226	4	1
	Glomar Shoal	4,662	64	36
	Herald Reef	286	4	2
	Imperieuse Reef	61	8	-
	Lightfoot Reef	814	5	4
	Locker Reef	116	3	1
	Madeleine Shoals	3,205	14	11
	Manicom Bank	137	3	1
	Meda Reef	191	7	1
	Mermaid Reef	77	2	-
	Montebello Shoals	5,088	19	5
	Ningaloo Reef	137	16	2
	O'Grady Shoal	412	4	2
	Paroo Shoal	163	3	1
	Penguin Bank	894	8	4
Rankin Bank	2,124	58	26	
Ripple Shoals	2,830	7	4	

0-10 m depth layer		Maximum entrained hydrocarbon exposure (ppb)	Probability of hydrocarbon exposure	
Receptor	Low		High	
	Rosily Shoals	383	5	2
	South East Reef	746	4	1
	Tongue Shoals	131	3	1
	Tryal Rocks	2,534	37	19
	Ward Reef	142	3	1
	Weeks Shoal	204	4	2
	West Reef	591	4	3
State Waters	Western Australia	21,667	32	14

Table 3-19 Probability of exposure to individual receptors from instantaneous entrained hydrocarbons in the 0-10 m depth layer. Results are based on a 250,000 bbl subsea release of Wandoo crude over 24 hours, tracked for 80 days during transitional conditions.

0-10 m depth layer		Maximum entrained hydrocarbon exposure (ppb)	Probability of hydrocarbon exposure	
Receptor	Low		High	
AMP	Abrolhos	170	9	1
	Carnarvon Canyon	211	22	2
	Dampier	87	3	-
	Eighty Mile Beach	19	2	-
	Gascoyne	4,594	83	42
	Montebello	31,724	89	77
	Ningaloo	2,607	65	21
	Perth Canyon	21	1	-
	Shark Bay	152	26	1
	South-west Corner	11	1	-
CP	Montebello Islands	7,768	33	14
FHPA	Abrolhos Islands	10	1	-
IBRA	Cape Range	9,806	36	17
	Edel	11	1	-
	Geraldton Hills	10	1	-
	Roebourne	1,552	19	7
IMCRA	Abrolhos Islands	12	1	-
	Central West Coast	14	1	-
	Leeuwin-Naturaliste	11	1	-
	Ningaloo	3,610	73	28
	Northwest Shelf	71,517	75	58
	Pilbara (nearshore)	2,501	21	4
	Zuytdorp	203	27	3
KEF	Ancient coastline at 125 m depth contour	17,166	93	68



APPENDIX 3

Oil Spill Trajectory Modelling

0-10 m depth layer		Maximum entrained hydrocarbon exposure (ppb)	Probability of hydrocarbon exposure	
Receptor			Low	High
	Ancient coastline at 90-120m depth	12	1	0
	Canyons linking the Cuvier Abyssal Plain and the Cape Range Peninsula	2,806	82	44
	Commonwealth marine environment surrounding the Houtman Abrolhos Islands	16	1	-
	Commonwealth marine environment within and adjacent to the west coast inshore lagoons	10	1	-
	Commonwealth waters adjacent to Ningaloo Reef	2,607	65	21
	Continental Slope Demersal Fish Communities	12,366	97	68
	Exmouth Plateau	3,680	74	35
	Glomar Shoals	5,650	30	22
	Perth Canyon and adjacent shelf break, and other west coast canyons	59	7	-
	Wallaby Saddle	143	8	1
	Western demersal slope and associated fish communities	157	20	1
	Western rock lobster	14	1	-
MMA	Barrow Island	5,967	36	11
	Muiron Islands	2,739	40	8
MP	Barrow Island	1,359	35	10
	Montebello Islands	11,782	59	34
	Ningaloo	3,610	45	8
NR	Thevenard Island	40	4	-
	Baylis Patches	22	1	-
RSB	Cooper Shoal	104	1	1
	Exmouth Reef	335	3	1
	Fairway Reef	211	8	1
	Glomar Shoal	3,977	24	11
	Hood Reef	165	15	1
	Locker Reef	35	1	-
	Madeleine Shoals	44	3	-
	Montebello Shoals	7,768	33	14
	Ningaloo Reef	3,019	34	3
	Outtrim Patches	2,419	32	5
	Pearl Reef	145	1	1
	Pelsaert Bank	10	1	-
	Poivre Reef	1,627	18	7
	Rankin Bank	1,784	46	31

0-10 m depth layer		Maximum entrained hydrocarbon exposure (ppb)	Probability of hydrocarbon exposure	
Receptor	Low		High	
	Ripple Shoals	79	5	-
	Rosily Shoals	584	16	2
	Schofield Shoal	15	1	-
	Taunton Reef	86	3	-
	Trap Reef	119	4	1
	Tryal Rocks	13,561	74	54
State Waters	Western Australia	11,782	59	34

Table 3-20 Probability of exposure to individual receptors from instantaneous entrained hydrocarbons in the 0-10 m depth layer. Results are based on a 250,000 bbl subsea release of Wandoo crude over 24 hours, tracked for 80 days during winter conditions.

0-10 m depth layer		Maximum entrained hydrocarbon exposure (ppb)	Probability of hydrocarbon exposure	
Receptor	Low		High	
AMP	Abrolhos	84	5	0
	Argo-Rowley Terrace	1,721	22	5
	Carnarvon Canyon	145	10	2
	Gascoyne	3,930	76	31
	Mermaid Reef	25	2	0
	Montebello	30,004	90	73
	Ningaloo	1,675	44	8
	Shark Bay	46	6	0
CP	Montebello Islands	4,262	46	28
IBRA	Cape Range	5,901	47	30
	Roebourne	543	17	3
IMCRA	Ningaloo	1,675	59	17
	Northwest Shelf	87,534	78	68
	Pilbara (nearshore)	495	9	2
	Zuytdorp	58	8	0
KEF	Ancient coastline at 125 m depth contour	16,066	88	59
	Canyons linking the Cuvier Abyssal Plain and the Cape Range Peninsula	3,414	63	26
	Commonwealth waters adjacent to Ningaloo Reef	1,675	44	8
	Continental Slope Demersal Fish Communities	16,487	85	57
	Exmouth Plateau	3,433	71	35
	Glomar Shoals	16,706	25	16
	Mermaid Reef and Commonwealth waters surrounding Rowley Shoals	503	3	2

0-10 m depth layer		Maximum entrained hydrocarbon exposure (ppb)	Probability of hydrocarbon exposure	
Receptor	Low		High	
	Wallaby Saddle	69	5	0
	Western demersal slope and associated fish communities	20	3	0
MMA	Barrow Island	5,848	42	22
	Muiron Islands	1,044	41	8
MP	Barrow Island	1,430	31	9
	Montebello Islands	9,261	62	46
	Ningaloo	1,591	22	4
	Rowley Shoals	400	3	2
NR	Great Sandy Island	55	1	0
	Thevenard Island	1,317	3	1
RSB	Barrow Island Reefs and Shoals	55	1	0
	Baylis Patches	14	1	0
	Clerke Reef	68	2	0
	Exmouth Reef	154	1	1
	Fairway Reef	254	4	1
	Flinders Shoal	21	1	0
	Glomar Shoal	3,475	13	8
	Hood Reef	403	10	1
	Imperieuse Reef	311	2	2
	Lightfoot Reef	20	1	0
	Locker Reef	27	2	0
	Mermaid Reef	13	2	0
	Montebello Shoals	3,227	46	28
	Ningaloo Reef	972	13	1
	Outtrim Patches	913	28	6
	Paroo Shoal	13	1	0
	Pearl Reef	39	1	0
	Poivre Reef	187	23	3
	Rankin Bank	4,069	63	44
	Ripple Shoals	104	2	1
	Rosily Shoals	2,020	17	3
	Taunton Reef	103	2	1
	Tongue Shoals	18	1	0
	Trap Reef	1,028	6	2
	Tryal Rocks	8,336	75	56
	West Reef	11	1	0
State Waters	Western Australia	11,245	65	47

Table 3-21 Probability of exposure to individual receptors from instantaneous entrained hydrocarbons in the 10-20 m depth layer. Results are based on a 250,000 bbl subsea release of Wandoo crude over 24 hours, tracked for 80 days during summer conditions.

10-20 m depth layer Receptor	Maximum entrained hydrocarbon exposure (ppb)	Probability of hydrocarbon exposure		
		Low	High	
AMP	Abrolhos	67	2	-
	Argo-Rowley Terrace	59	12	-
	Carnarvon Canyon	60	6	-
	Dampier	114	8	1
	Eighty Mile Beach	82	5	-
	Gascoyne	135	27	1
	Montebello	348	38	6
	Ningaloo	73	17	-
	Shark Bay	45	4	-
CP	Montebello Islands	100	10	1
EEZ	Indonesian Exclusive Economic Zone	14	1	-
IBRA	Cape Range	262	12	1
	Chichester	18	2	-
	Roebourne	119	7	1
IMCRA	Eighty Mile Beach	20	1	-
	Ningaloo	83	21	-
	Northwest Shelf	437	80	37
	Pilbara (nearshore)	182	11	2
	Zuytdorp	64	6	-
KEF	Ancient coastline at 125 m depth contour	213	49	6
	Canyons linking the Cuvier Abyssal Plain and the Cape Range Peninsula	135	27	1
	Commonwealth waters adjacent to Ningaloo Reef	73	17	-
	Continental Slope Demersal Fish Communities	169	47	2
	Exmouth Plateau	120	15	1
	Glomar Shoals	262	44	11
	Mermaid Reef and Commonwealth waters surrounding Rowley Shoals	16	2	-
	Wallaby Saddle	28	2	-
	Western demersal slope and associated fish communities	25	2	-
MMA	Barrow Island	296	13	2
	Muiron Islands	29	9	-
MP	Barrow Island	291	10	2
	Montebello Islands	183	17	2

10-20 m depth layer		Maximum entrained hydrocarbon exposure (ppb)	Probability of hydrocarbon exposure	
Receptor	Low		High	
	Ningaloo	63	10	-
	Rowley Shoals	15	2	-
NR	Great Sandy Island	34	2	-
	Thevenard Island	17	2	-
	Barrow Island Reefs and Shoals	42	2	-
	Exmouth Reef	10	1	-
	Fortescue Reef	10	1	-
	Glomar Shoal	151	34	3
	Herald Reef	10	1	-
	Imperieuse Reef	13	1	-
	Lightfoot Reef	15	2	-
	Madeleine Shoals	108	8	1
RSB	Meda Reef	31	1	-
	Montebello Shoals	96	10	-
	Ningaloo Reef	48	7	-
	O'Grady Shoal	12	1	-
	Penguin Bank	43	3	-
	Rankin Bank	103	37	1
	Ripple Shoals	29	4	-
	Rosily Shoals	15	2	-
	South East Reef	11	1	-
	Tryal Rocks	86	22	-
Weeks Shoal	11	1	-	
West Reef	14	2	-	
State Waters	Western Australia	350	17	3

Table 3-22 Probability of exposure to individual receptors from instantaneous entrained hydrocarbons in the 10-20 m depth layer. Results are based on a 250,000 bbl subsea release of Wandoo crude over 24 hours, tracked for 80 days during transitional conditions.

10-20 m depth layer		Maximum entrained hydrocarbon exposure (ppb)	Probability of hydrocarbon exposure	
Receptor	Low		High	
AMP	Abrolhos	27	3	-
	Carnarvon Canyon	31	7	-
	Gascoyne	97	45	-
	Montebello	280	75	22
	Ningaloo	101	30	1
	Shark Bay	21	5	-

10-20 m depth layer		Maximum entrained hydrocarbon exposure (ppb)	Probability of hydrocarbon exposure	
Receptor			Low	High
CP	Montebello Islands	42	12	-
IBRA	Cape Range	81	16	-
	Roebourne	15	2	-
IMCRA	Central West Coast	10	1	-
	Ningaloo	110	34	1
	Northwest Shelf	313	43	11
	Pilbara (nearshore)	59	5	-
	Zuytdorp	27	7	-
	Ancient coastline at 125 m depth contour	125	60	1
KEF	Canyons linking the Cuvier Abyssal Plain and the Cape Range Peninsula	86	49	-
	Commonwealth marine environment surrounding the Houtman Abrolhos Islands	12	1	-
	Commonwealth waters adjacent to Ningaloo Reef	101	30	1
	Continental Slope Demersal Fish Communities	181	64	2
	Exmouth Plateau	87	26	-
	Glomar Shoals	131	14	1
	Perth Canyon and adjacent shelf break, and other west coast canyons	12	1	-
	Wallaby Saddle	25	3	-
	Western demersal slope and associated fish communities	27	3	-
	Western rock lobster	10	1	-
MMA	Barrow Island	65	13	-
	Muiron Islands	73	21	-
MP	Barrow Island	24	12	-
	Montebello Islands	139	35	2
	Ningaloo	110	19	1
RSB	Cooper Shoal	12	1	-
	Exmouth Reef	24	1	-
	Fairway Reef	20	1	-
	Glomar Shoal	65	7	-
	Hood Reef	17	2	-
	Montebello Shoals	26	12	-
	Ningaloo Reef	81	9	-
	Outtrim Patches	50	9	-
	Pearl Reef	11	1	-

10-20 m depth layer		Maximum entrained hydrocarbon exposure (ppb)	Probability of hydrocarbon exposure	
Receptor	Low		High	
	Poivre Reef	13	1	-
	Rankin Bank	44	19	-
	Rosily Shoals	29	4	-
	Tryal Rocks	242	51	1
State Waters	Western Australia	142	37	2

Table 3-23 Probability of exposure to individual receptors from instantaneous entrained hydrocarbons in the 10-20 m depth layer. Results are based on a 250,000 bbl subsea release of Wandoo crude over 24 hours, tracked for 80 days during winter conditions.

10-20 m depth layer		Maximum entrained hydrocarbon exposure (ppb)	Probability of hydrocarbon exposure	
Receptor	Low		High	
AMP	Abrolhos	17	2	-
	Argo-Rowley Terrace	22	3	-
	Carnarvon Canyon	19	2	-
	Gascoyne	76	30	-
	Montebello	223	66	9
	Ningaloo	86	17	-
	Shark Bay	17	3	-
CP	Montebello Islands	26	13	-
IBRA	Cape Range	90	18	-
	Roebourne	16	2	-
IMCRA	Ningaloo	86	29	-
	Northwest Shelf	213	43	11
	Pilbara (nearshore)	27	2	-
	Zuytdorp	19	3	0
KEF	Ancient coastline at 125 m depth contour	137	50	2
	Canyons linking the Cuvier Abyssal Plain and the Cape Range Peninsula	92	37	-
	Commonwealth waters adjacent to Ningaloo Reef	86	17	-
	Continental Slope Demersal Fish Communities	122	53	1
	Exmouth Plateau	67	29	-
	Glomar Shoals	114	12	1
	Mermaid Reef and Commonwealth waters surrounding Rowley Shoals	11	1	-
	Wallaby Saddle	13	1	-

10-20 m depth layer		Maximum entrained hydrocarbon exposure (ppb)	Probability of hydrocarbon exposure		
Receptor			Low	High	
	Western demersal slope and associated fish communities	11	1	-	
MMA	Barrow Island	61	20	-	
	Muiron Islands	38	16	-	
MP	Barrow Island	54	11	-	
	Montebello Islands	110	41	1	
	Ningaloo	86	5	-	
NR	Thevenard Island	22	1	-	
RSB	Fairway Reef	10	1	-	
	Glomar Shoal	50	7	-	
	Hood Reef	12	1	-	
	Montebello Shoals	26	12	-	
	Ningaloo Reef	43	1	-	
	Outtrim Patches	25	10	-	
	Rankin Bank	39	20	-	
	Ripple Shoals	16	1	-	
	Rosily Shoals	36	4	-	
	Taunton Reef	16	1	-	
	Trap Reef	40	1	-	
	Tryal Rocks	79	53	-	
	SHORE	Airlie Island	16	2	-
		Barrow Island	39	8	-
Bessieres Island		90	6	-	
Exmouth		33	2	-	
Flat Island		30	4	-	
Lowendal Island		46	6	-	
Middle Island		11	1	-	
Montebello Islands		40	18	-	
Murion Islands		30	10	-	
Observation Island		13	1	-	
Peak Island		28	9	-	
Serrurier Island		51	3	-	
Sunday Island		21	3	-	
Table Island		34	1	-	
Thevenard Island		30	1	-	
Tortoise Island	18	1	-		
State Waters	Western Australia	153	42	2	

Table 3-24 Probability of exposure to individual receptors from instantaneous entrained hydrocarbons in the 20-30 m depth layer. Results are based on a 250,000 bbl subsea release of Wandoo crude over 24 hours, tracked for 80 days during summer conditions.

Receptor	20-30 m depth layer	Maximum entrained hydrocarbon exposure (ppb)	Probability of hydrocarbon exposure	
			Low	High
AMP	Abrolhos	18	1	-
	Argo-Rowley Terrace	14	1	-
	Carnarvon Canyon	22	1	-
	Dampier	29	2	-
	Eighty Mile Beach	12	1	-
	Gascoyne	21	3	-
	Montebello	31	10	-
	Ningaloo	21	3	-
	Shark Bay	14	2	-
CP	Montebello Islands	17	2	-
IBRA	Cape Range	21	2	-
	Roebourne	18	2	-
IMCRA	Ningaloo	24	3	-
	Northwest Shelf	53	27	-
	Pilbara (nearshore)	32	3	-
	Zuytdorp	16	2	-
KEF	Ancient coastline at 125 m depth contour	43	12	-
	Canyons linking the Cuvier Abyssal Plain and the Cape Range Peninsula	23	3	-
	Commonwealth waters adjacent to Ningaloo Reef	21	3	-
	Continental Slope Demersal Fish Communities	21	5	-
	Exmouth Plateau	22	3	-
	Glomar Shoals	42	9	-
	Wallaby Saddle	14	1	-
	Western demersal slope and associated fish communities	16	1	-
MMA	Barrow Island	21	3	-
	Muiron Islands	11	1	-
MP	Barrow Island	16	2	-
	Montebello Islands	24	4	-
	Ningaloo	24	3	-
RSB	Glomar Shoal	33	5	-
	Madeleine Shoals	28	1	-
	Montebello Shoals	15	1	-

20-30 m depth layer		Maximum entrained hydrocarbon exposure (ppb)	Probability of hydrocarbon exposure	
Receptor	Low		High	
	Ningaloo Reef	19	3	-
	Rankin Bank	15	4	-
State Waters	Western Australia	38	4	-

Table 3-25 Probability of exposure to individual receptors from instantaneous entrained hydrocarbons in the 20-30 m depth layer. Results are based on a 250,000 bbl subsea release of Wandoo crude over 24 hours, tracked for 80 days during transitional conditions.

20-30 m depth layer		Maximum entrained hydrocarbon exposure (ppb)	Probability of hydrocarbon exposure	
Receptor	Low		High	
AMP	Abrolhos	13	1	-
	Carnarvon Canyon	11	1	-
	Gascoyne	23	5	-
	Montebello	32	28	-
	Ningaloo	21	4	-
IBRA	Cape Range	14	1	-
IMCRA	Ningaloo	21	4	-
	Northwest Shelf	33	14	-
	Zuytdorp	11	1	-
KEF	Ancient coastline at 125 m depth contour	23	6	-
	Canyons linking the Cuvier Abyssal Plain and the Cape Range Peninsula	17	4	-
	Commonwealth waters adjacent to Ningaloo Reef	21	4	-
	Continental Slope Demersal Fish Communities	24	6	-
	Exmouth Plateau	21	4	-
	Glomar Shoals	18	3	-
	Western demersal slope and associated fish communities	10	1	-
MMA	Barrow Island	17	2	-
	Muiron Islands	12	1	-
MP	Montebello Islands	22	3	-
	Ningaloo	16	2	-
RSB	Glomar Shoal	12	1	-
	Ningaloo Reef	11	1	-
	Tryal Rocks	17	3	-
State Waters	Western Australia	24	5	-

Table 3-26 Probability of exposure to individual receptors from instantaneous entrained hydrocarbons in the 20-30 m depth layer. Results are based on a 250,000 bbl subsea release of Wandoo crude over 24 hours, tracked for 80 days during winter conditions.

20-30 m depth layer		Maximum entrained hydrocarbon exposure (ppb)	Probability of hydrocarbon exposure	
Receptor			Low	High
AMP	Argo-Rowley Terrace	10	1	-
	Gascoyne	20	3	-
	Montebello	46	20	-
	Ningaloo	14	1	-
IBRA	Cape Range	11	1	-
IMCRA	Ningaloo	14	1	-
	Northwest Shelf	29	7	-
KEF	Ancient coastline at 125 m depth contour	23	11	-
	Canyons linking the Cuvier Abyssal Plain and the Cape Range Peninsula	20	4	-
	Commonwealth waters adjacent to Ningaloo Reef	14	1	-
	Continental Slope Demersal Fish Communities	22	8	-
	Exmouth Plateau	18	2	-
	Glomar Shoals	21	3	-
	MMA	Barrow Island	14	2
MP	Muiron Islands	15	1	-
	Barrow Island	15	2	-
	Montebello Islands	24	7	-
RSB	Ningaloo	10	1	-
	Glomar Shoal	15	1	-
	Rankin Bank	12	1	-
	Tryal Rocks	12	3	-
State Waters	Western Australia	30	8	-

3.4 Weathering and Fate

Figure 3-12 displays the time-series of the area of visible surface oil (or low threshold $>1 \text{ g/m}^2$) and actionable oil ($>10 \text{ g/m}^2$), and length of actionable shoreline oil ($>100 \text{ g/m}^2$) over the 80-day simulation period, for the deterministic trajectory that resulted in the largest volume of oil ashore above 100 g/m^2 . Figure 3-13 presents the fates and weathering graph for the corresponding spill trajectory.

The maximum area of coverage of visible oil on the sea surface was predicted to occur 14 days after the spill started and cover approximately $1,205 \text{ km}^2$. The maximum length of actionable shoreline oil occurred on day 23 with approximately 355 km of shoreline contacted.

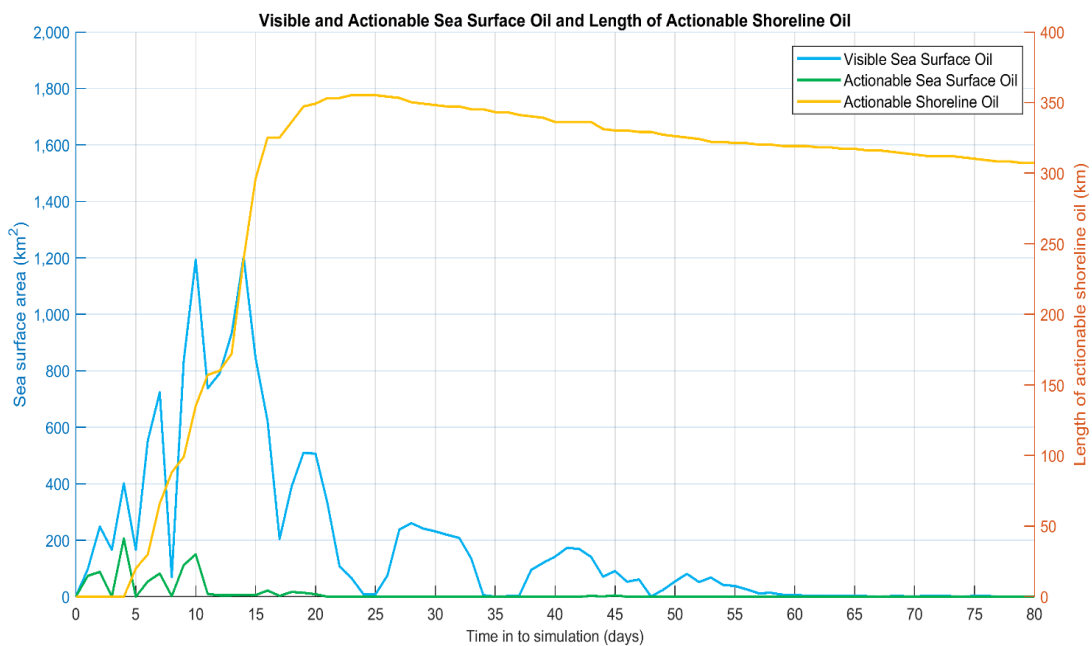

Figure 3-12 Time-series of the area of low exposure (or visible sea surface oil at 1 g/m^2) and actionable (10 g/m^2) surface oil (left axis) and length of actionable shoreline oil (100 g/m^2 ; right axis) for the trajectory with the largest volume of oil ashore.

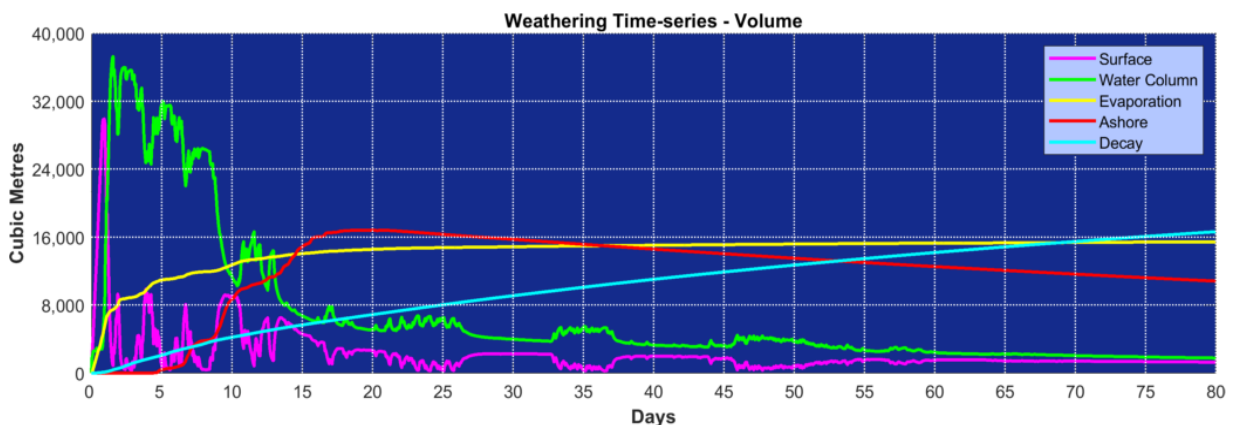

Figure 3-13 Predicted weathering and fates graph for the trajectory with the largest volume of oil ashore.

3.5 CGS Dispersant Needs Analysis

Table 3-27: Area of floating oil between 50 g/m² and 100 g/m², area of floating oil above 100 g/m² over time for the run that resulted in the quickest time for floating oil to reach the Montebello AMP

	6 hrs	12 hrs	18 hrs	24 hrs	Day 2	Day 5	Day 10	Day 20	Day 30
Area of floating oil on the sea surface between >50g/m ² and <100g/m ² (km ²)	1	2	15	5	30	18	4	-	-
Area of floating oil on the sea surface >100g/m ² (km ²)	2	2	11	4	-	-	-	-	-
Total dispersant needed (m ³)	7.5	10	65	22.5	75	45	10	0	0

Table 3-28: Area of floating oil between 50 g/m² and 100 g/m², area of floating oil above 100 g/m² over time for the run that resulted in the minimum time before shoreline accumulation above 10 g/m².

	6 hrs	12 hrs	18 hrs	24 hrs	Day 2	Day 5	Day 10	Day 20	Day 30
Area of floating oil on the sea surface between >50g/m ² and <100g/m ² (km ²)	5	8	12	2	3	11	7	-	-
Area of floating oil on the sea surface >100g/m ² (km ²)	4	21	15	1	-	5	-	-	-
Total dispersant needed (m ³)	22.5	72.5	67.5	7.5	7.5	40	17.5	0	0

Table 3-29: Area of floating oil between 50 g/m² and 100 g/m², area of floating oil above 100 g/m² over time for the run that resulted in the longest length of shoreline accumulation above 100 g/m²

	6 hrs	12 hrs	18 hrs	24 hrs	Day 2	Day 5	Day 10	Day 20	Day 30
Area of floating oil on the sea surface between >50g/m ² and <100g/m ² (km ²)	-	1	3	13	24	-	-	-	-
Area of floating oil on the sea surface >100g/m ² (km ²)	2	2	4	14	6	-	-	-	-
Total dispersant needed (m ³)	5	7.5	17.5	67.5	75	0	0	0	0

Table 3-30: Area of floating oil between 50 g/m² and 100 g/m², area of floating oil above 100 g/m² over time for the run that resulted in the largest volume of oil ashore.

	6 hrs	12 hrs	18 hrs	24 hrs	Day 2	Day 5	Day 10	Day 20	Day 30
Area of floating oil on the sea surface between >50g/m ² and <100g/m ² (km ²)	2	1	4	8	10	-	1	-	-
Area of floating oil on the sea surface >100g/m ² (km ²)	10	25	34	40	-	-	5	-	-
Total dispersant needed (m ³)	30	65	95	120	25	0	15	0	0

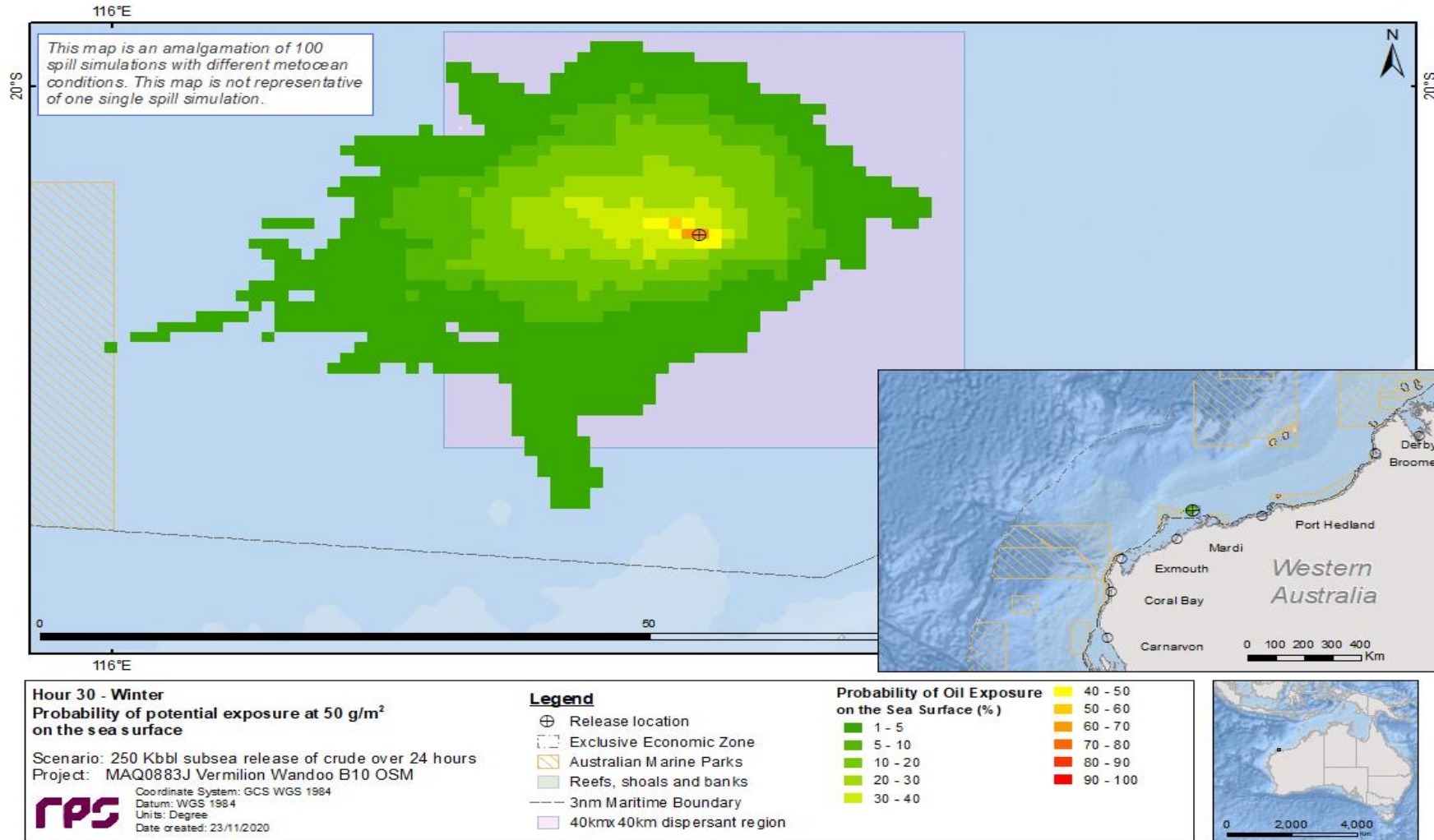



Figure 3-14 Probability of sea-surface exposure (above 50 g/m²) at hour 30 during winter conditions

Appendix 4: PFW Composition and Modelling

	APPENDIX 4
	PFW Composition and Discharge Modelling Results

1. PFW COMPOSITION

Table 1-1 Concentrations of PAHs and BTEX components in Wandoo PFW

Group	Parameter	Units	ANZECC Guidelines		Concentrations µg/L											
			95%	99%	1998	2002	2008	2010	2012	2014	2015	2016	2017	2018	2019	2020
PAH	Naphthalene	µg/L	70	50	<0.5	0.7	1.4	1.2	0.51	<1.0	<1.0	-	<1.0	<1.0	<1.0	<1.0
	Acenaphthylene	µg/L	-	-	<0.5	<0.5	<0.1	<0.1	<0.1	<1.0	<1.0	-	<1.0	<1.0	<0.1	<0.1
	Acenaphthene	µg/L	-	-	<0.5	<0.5	<0.1	<0.1	<0.1	<1.0	<1.0	-	<1.0	<1.0	<0.1	<0.2
	Fluorene	µg/L	-	-	<0.5	0.7	<0.1	<0.1	<0.1	<1.0	<1.0	-	<1.0	<1.0	<0.1	<0.1
	Phenanthrene	µg/L	2	0.6	0.5	0.9	<0.1	<0.1	<0.1	<1.0	<1.0	-	<1.0	<1.0	<0.1	<0.1
	Anthracene	µg/L	0.4	0.01	0.5	<0.5	<0.1	<0.1	<0.1	<1.0	<1.0	-	<1.0	<1.0	<0.1	<0.1
	Fluoranthene	µg/L	1.4	1	<0.5	<0.5	<0.1	<0.1	<0.1	<1.0	<1.0	-	<1.0	<1.0	<0.1	<0.1
	Pyrene	µg/L	-	-	0.8	1.5	0.91	1.6	1.0	<1.0	<1.0	-	<1.0	<1.0	0.2	0.2
	Benz(a)anthracene	µg/L	-	-	<0.5	1.8	0.1	<0.1	<0.1	<1.0	<1.0	-	<1.0	<1.0	<0.1	<0.1
	Chrysene	µg/L	-	-	<0.5	1.8	0.79	1.2	<0.10	<1.0	<1.0	-	<1.0	<1.0	<0.1	<0.1
	Benzo(b)&(k)fluoroanthene	µg/L	-	-	-	-	0.55	<0.2	<0.10	<2.0	<2.0	-	<2.0	<2.0	<0.2	<0.2
	Benzo(a)pyrene	µg/L	-	-	<0.5	<0.5	0.22	<0.1	0.13	<1.0	<1.0	-	<1.0	<1.0	<0.1	<0.1
	Indeno(1,2,3-cd)pyrene	µg/L	-	-	<0.5	<0.5	<0.1	<0.1	<0.1	<1.0	<1.0	-	<1.0	<1.0	<0.1	<0.1
	Dibenz(a,h)anthracene	µg/L	-	-	<0.5	<0.5	<0.1	<0.1	<0.1	<1.0	<1.0	-	<1.0	<1.0	<0.1	<0.1
	Benzo(g,h,i)perylene	µg/L	-	-	<0.5	<0.5	0.26	<0.1	0.28	<1.0	<1.0	-	<1.0	<1.0	<0.1	<0.1
Total PAH	µg/L	-	-	-	-	-	-	-	<16	<16	-	<16	<16	0.4	0.4	
BTEX	Benzene	µg/L	700	500	<0.5	<1	<0.1	<0.1	<0.1	<1.0	<1.0	<1.0	<1.0	<1.0	<1.0	<1.0
	Toluene	µg/L	180	110	<0.5	<1	<0.1	<0.1	<0.1	<1.0	<1.0	<1.0	<1.0	<1.0	<1.0	<1.0
	Ethylbenzene	µg/L	80	50	<0.5	<1	<0.1	<0.1	<0.1	<1.0	<1.0	<1.0	<1.0	<1.0	<1.0	<1.0
	Xylene	µg/L	-	-	<1.5	<3	<0.2	<0.2	<0.2	<2.0	<2.0	<2.0	<2.0	<2.0	<1.0	<1.0
	Total BTEX	µg/L	-	-	-	-	<0.5	<0.5	<5.0	<5.0	<5.0	<5.0	<5.0	<5.0	<2.0	<2.0
TRH	C6 – C9 Fraction	µg/L	-	-	-	-	-	-	-	<25	<25	<25	<25	<25	<10	<10
	C6 – C10 Fraction	µg/L	-	-	-	-	-	-	-	-	<25	<25	<25	<25	<10	<10
	C10 – C14 Fraction	µg/L	-	-	-	-	-	-	-	750	1,100	400	490	680	300	450
	>C10 – C16 Fraction	µg/L	-	-	-	-	-	-	-	-	1,100	1,300	1,700	700	580	890
	C15 – C28 Fraction	µg/L	-	-	-	-	-	-	-	6,900	5,600	5,100	5,100	5,200	2,100	3,500
	>C16 – C34 Fraction	µg/L	-	-	-	-	-	-	-	-	-	7,300	7,500	7,000	2,200	3,900
	C29 – C36 Fraction	µg/L	-	-	-	-	-	-	-	2,100	-	2,200	1,700	1,400	490	1,100
>C34 – C40 Fraction	µg/L	-	-	-	-	-	-	-	-	-	1,100	830	660	230	620	

Table 1-2 Concentrations of inorganic parameters in Wandoo PFW

Group	Parameter	Units	ANZECC Guidelines		Concentrations													
			95%	99%	1998	2002	2008	2010	2012	2014	2015	2016	2017	2018	2019	2020		
Dissolved Metals	Arsenic	mg/L	-	-	-	-	-	-	-	-	<0.005	<0.005	<0.001	<0.001	<0.001	<0.001	<0.001	
	Barium	mg/L	-	-	-	-	-	-	-	-	9.9	11	11	12	12	8.6	7.9	
	Cadmium	mg/L	0.0055	0.007	-	-	-	-	-	-	<0.002	<0.002	<0.0001	<0.0001	<0.001	<0.002	<0.002	
	Copper	mg/L	0.0013	0.0003	-	-	-	-	-	-	<0.001	<0.005	<0.001	<0.001	<0.001	0.002	0.004	
	Iron	mg/L	-	-	-	-	0.31	<0.005	0.71	0.13	0.005	0.067	0.01	1.8	0.82	0.01		
	Lead	mg/L	0.0044	0.0022	-	-	-	-	-	-	<0.001	<0.001	<0.001	<0.001	<0.001	<0.001	<0.001	
	Manganese	mg/L	-	-	-	-	-	-	-	-	-	-	0.078	0.072	0.063	0.08	0.05	
	Nickel	mg/L	0.070	0.007	-	-	-	-	-	-	<0.005	<0.005	<0.001	<0.001	<0.001	0.007	<0.01	
	Selenium	mg/L	-	-	-	-	-	-	-	-	-	-	<0.001	<0.001	<0.002	<0.001	<0.001	
	Strontium	mg/L	-	-	-	-	-	-	-	-	28	5	16	25	25	25	22	
	Zinc	mg/L	0.015	0.007	-	-	-	-	-	-	<0.005	<0.005	<0.002	0.002	0.034	<0.01	<0.01	
	Hexavalent Chromium	Mercury	mg/L	0.0004	0.0001	<0.0005	0.0001	<0.0001	<0.001	<0.0001	0.0001	<0.00005	<0.0001	<0.001	<0.001	0.0008	<0.0002	
Trivalent Chromium		mg/L	0.0274	0.0077	-	-	-	-	-	<0.005	<0.005	<0.001	0.002	0.002	<0.001	<0.001		
Hexavalent Chromium	Hexavalent Chromium	mg/L	0.0044	0.00014	-	-	-	-	-	0.008	<0.004	0.001	<0.001	<0.001	<0.002	<0.002		
Inorganics	Chloride	mg/L	-	-	21,000	19,000	20,000	20,160	19,000	21,000	21,000	21,000	20,000	20,000	19,994	20,221		
	Conductivity a25°C	uS/cm	-	-	-	-	-	-	-	51,300	50,900	51,500	51,100	52,400				
	Conductivity a15°C	Ms/cm													-	46	48	
	Total Nitrogen (Calc)	mg/L	-	-	-	-	-	-	-	-	-	9	40	40	40	40		
	Nitrate as Na ₃ -N (Calc)	mg/L	-	-	<0.2	<0.01	<0.010	<0.010	<0.010	-	-	-	-	-	-	-	-	
	pH	-	-	-	-	-	6.9	6.9	6.8	7.5	6.8	6.8	7	6.9	6.68	6.83		
	Phosphorus (T)	mg/L	-	-	-	-	-	-	-	-	-	-	<0.1	<0.1	0.19			
	Salinity (Calc)	mg/L	-	-	-	-	-	29,200	33,200	33,600	33,300	33,700	33,400	34,000	29,440	30,720		
	Sulphate	mg/L	-	-	80	<3	<5	<5	<5	-	-	0.03	-	-	-	-	-	
	Sulphite (SO ₃)	mg/L	-	-	-	-	-	-	-	-	-	<2	2	<5	<2	<2		
	Sulfide	mg/L	-	-	-	-	-	-	-	<0.02	0.02	<2	0.04	0.02	0.2	0.03		
	Turbidity	NTU	-	-	-	-	-	-	-	40	30	32	25	36	31	25.6		
	TSS	mg/L	-	-	-	-	-	-	-	17	12	10	11	13	36	12.9		
	TDS	mg/L	-	-	-	-	-	-	-	-	-	35,200	33,800	35,100	33,820	34,400		
ToC	mg/L	-	-	-	-	-	-	-	-	-	5	4	5	6	6			

Table 1-3 Concentrations of alkylphenols in Wandoo PFW

Group	Parameter	Units	Guidelines		Concentrations							
			95%	99%	2014	2015	2016	2017	2018	2019	2020	
Phenolic Compounds	Phenol	µg/l	400	270	<1.0	<1.0	<1.0	<1.0	<1.0	<1.0	<1	<1
	2-Chlorophenol	µg/l	-	-	<1.0	<1.0	<1.0	<1.0	<1.0	<1.0	<1	<1
	4-Chlorophenol	µg/l	-	-	<1.0	<1.0	-	-	-	-	-	-
	2,4-Dichlorophenol	µg/l	-	-	<1.0	<1.0	<1.0	<1.0	<1.0	<1.0	<1	<1
	3,4-Dichlorophenol	µg/l	-	-	<1.0	-	<1.0	<1.0	<1.0	<1.0	-	-
	2,6-Dichlorophenol	µg/l	-	-	-	<1.0	-	-	<1.0	-	-	<1
	2,4,5-Trichlorophenol	µg/l	-	-	<2.0	<2.0	<1.0	<1.0	<2.0	<2.0	<1	<1
	2,4,6-Trichlorophenol	µg/l	-	-	<2.0	<2.0	<2.0	<2.0	<2.0	<2.0	<1	<1
	4-Chloro-2-Methylphenol	µg/l	-	-	<2.0	-	<2.0	<2.0	-	-	-	-
	2-Methylphenol	µg/l	-	-	<1.0	<1.0	-	-	<1.0	-	-	<1
	2-Ethylphenol	µg/l	-	-	<1.0	-	<1.0	<1.0	-	-	-	-
	4-Chloro-3-Methylphenol	µg/l	-	-	<2.0	<2.0	-	-	<2.0	<2.0	<2	<2
	3- & 4-Methylphenol	µg/l	-	-	-	<2.0	<2.0	<2.0	<2.0	<2.0	<2	<2
	2-Nitrophenol	µg/l	-	-	-	<1.0	<2.0	<2.0	<2.0	<1.0	-	<1
	4-Nitrophenol	µg/l	-	-	-	<1.0	<1.0	<1.0	<1.0	<1.0	<1	<1
Pentachlorophenol	µg/l	-	-	-	<2.0	<1.0	<1.0	<1.0	<2.0	<1	<1	

Table 1-4 Total ammonia concentration in PFW

Parameter	Concentration (mg/L)																				
	2010	2012	2013	2014	2015	2015	2016	2016	2016	2016	2016	2016	2016	2016	2016	2017	2017	2017	2018	2019	2020
					May	Sept	Mar	Apr	May	Jul	Aug	Sept	Oct	Nov	Dec	Jan	Feb	Mar	Monthly Average	Monthly Average	Monthly Average (to July 1)
Total ammonia (DTA)	39.8	30.1	-	-	31.9	-	-	-	-	-	-	-	-	-	-	-	-	-	-	-	-
Total ammonia (as NH3-N) from chemical assessment	-	-	33	40	44	42	41	42	9*	41	39	44	43	41	44	41	42	39	38.9	40.9	37.2

Table 1-5 Quaternary amine compounds concentration in PFW

Parameter	Units	Concentrations				
		2016	2017	2018	2019	2020
DDAC-10 (DM-DC 10)	mg/kg	<0.01	<0.01	<0.01	<0.1	<0.1
BAC-10 (BDM-C10)	mg/kg	<0.01	<0.01	<0.01	<0.1	<0.1
BAC-12 (BDM-C12)	mg/kg	0.017	<0.01	0.037	<0.1	<0.1
BAC-14 (BDM-C14)	mg/kg	<0.01	<0.01	<0.01	<0.1	<0.1
BAC-16 (BDM-C16)	mg/kg	<0.01	<0.01	<0.01	<0.1	<0.1
Total BAC	mg/kg	0.017	<0.01	0.037	<0.1	<0.1

	APPENDIX 4
	PFW Composition and Discharge Modelling Results

Table 1-6 Radionuclide radioactivity in PFW

Parameter	Radioactivity (Bq/L)							
	1994	2008	2014	2015	2016	2017	2018	2019
Radium-226	0.93 - 1.03	1.32 ± 0.27	1.00 ± 0.14	1.19 ± 0.15	1.30 ± 0.18	1.1	1.02	1.40 ± 0.5
Radium-228	1.28 - 1.86	3.74 ± 0.53	2.66 ± 0.47	1.35 ± 0.22	2.43 ± 0.37	2.5	2.52	3.10 ± 0.6
Thorium-228	<0.1	<0.1	<0.1	<0.1	0.113 ± 0.02	<0.29	<0.20	<0.8
Potassium-40	2.27 - 9.48	3.33 ± 0.51	2.17 ± 0.30	3.68 ± 0.49	3.19 ± 0.34	6.4	6.6	7 ± 2
Uranium-235	-	-	-	-	-	<0.20	<0.20	<0.04

Table 1-7 Toxicity results for PFW

Test performed	Parameter	% (Mean ± range)								
		2006	2008	2010	2012	2015	2017	2018	2019	2020
72-hour sea urchin larval development test using <i>Heliocidaris tuberculata</i> / <i>Echinometra mathaei</i>	72-hr LC ₁₀	-	-	6.8 (6.4-9.1)	3.7 (3.1-3.9)	6.6 (6.5-6.8)	-	-	-	-
	72-hr EC ₁₀	-	-	-	-	-	4.46	3.25	3.7	1.0
	72-hr EC ₅₀	9.2 (9.1-9.3)	8.8 (6.25-12.5) ²	8.8 (8.7-8.8)	4.9 (4.7-5.0)	8.8 (8.8-8.9)	5.62	4.99	5.1	1.4
	NOEC	6.25	6.25	6.3	3.1	6.3	3.1	1.6	3.1	0.8
	LOEC	12.5	12.5	12.5	6.3	<6.3	6.3	3.1	6.3	1.6
48-hour larval development test using mussel <i>Mytilus galloprovincialis</i>	48-hr LC ₁₀	-	-	7.3 (4.2-11.9)	6.9 (6.5-7.1)	-	-	-	-	-
	48-hr EC ₅₀	-	-	13.5 (12.8-14.3)	10.0 (9.8-10.3)	-	-	-	-	-
	NOEC	-	-	6.3	6.3	-	-	-	-	-
	LOEC	-	-	12.5	12.5	-	-	-	-	-
48-hour larval development test using the rock oyster <i>Saccostrea commercialis</i> / <i>Mytilus edulis</i>	48-hr LC ₅₀	-	-	-	-	6.8 (6.6-6.9)	-	-	-	-
	48-hr EC ₁₀	-	-	-	-	-	4.21	-	3.7	-
	48-hr EC ₅₀	11.1 (10.6-11.7)	8.7 (8.6-8.8)	-	-	9.2 (9.1-9.4)	5.49	-	5.0	-
	NOEC	6.25	6.25	-	-	6.3	3.1	-	3.1	-
96-hour survival bioassay test using tiger prawn <i>Penaeus monodon</i> / amphipod <i>Corophium sp</i>	LOEC	12.5	12.5	-	-	12.5	6.3	-	6.3	-
	96-hr LC ₁₀	-	-	4.3	25.1 ¹	-	-	-	-	-
	96-hr LC ₅₀	37.2 (33.2-41.6)	-	>12.5	-	-	-	-	-	-
	96-hr EC ₁₀	-	-	-	-	-	8.13	-	16.7 (1.67)	-
	96-hr EC ₅₀	-	27 (22.8-32) ³	-	41.3 (18.6-53.6)	-	21.7	-	36.0	-
	NOEC	25	12.5	12.5	25	-	6.3	-	12.5	-
96-hour acute toxicity test using amphipod <i>Melita plumulosa</i>	LOEC	50	25	>12.5	50	-	12.5	-	25	-
	96-hr EC ₁₀	-	-	1.3 (0.4-2.1)	-	21.3 (14.8-39.1)	-	-	-	-
	96-hr-EC ₅₀	-	-	3.2 (1.9-4.5)	-	33.9 (29.1-39.4)	-	-	-	-
	NOEC	-	-	1.6	-	25	-	-	-	-
72-hour marine algal growth test using <i>Isochrysis aff. Galbana</i>	LOEC	-	-	3.1	-	50	-	-	-	-
	72-hr LC ₁₀	-	-	8.0 (7.7-8.3)	21.4 (15.7-30.3)	7.2 ¹	-	-	-	-
	72-hr LC ₅₀	49.6 (44.3-57.4)	15.1 (13.2-16.7)	17.0 (14.9-18.4)	35.5 (32.6-38.2)	10.7 (9.9-11.5)	-	-	-	-
	72-hr EC ₁₀	-	-	-	-	-	21.9	20.7	16.1	7.3
	72-hr EC ₅₀	-	-	-	-	-	44.0	48.2	24.1	11.6
	NOEC	25	12.5	6.3	25	6.3	25	12.5	1.6	6.3
LOEC	50	25	12.5	50	12.5	50	25	3.1	12.5	

Test performed	Parameter	% (Mean ± range)								
		2006	2008	2010	2012	2015	2017	2018	2019	2020
Microtox® testing using the bacteria <i>Vibrio fischeri</i>	5-min EC ₅₀	70 (67-73)	>90	13.1	4.1 (3.7-4.4)	5.2 (4.99-5.51)	-			-
	15-min EC ₁₀	-	-	-	-	-	1.28			0.31
	15-min EC ₅₀	35 (31-40)	>-90	7.7	2.2 (2.1-2.2)	3.3 (3.13-3.56)	11.8			3.0
	NOEC	-	-	-	-	-	0.4			<0.4
	LOEC	-	-	-	-	-	0.8			0.4
7-day copepod larval development test using <i>Gladioferens imparipes</i>	7-day EC ₁₀	-	-	-	-	-	0.72			2.9
	7-day EC ₅₀	-	-	-	-	-	6.9			3.6
	NOEC	-	-	-	-	-	0.8			3.1
	LOEC	-	-	-	-	-	1.6			6.3
72-hours microalgal cell division bioassay (<i>Nitzschia closterium</i>)	EC ₁₀									6.1
	EC ₅₀									17.9
	NOEC									6.3
	LOEC									12.5
1-hr Sea urchin fertilisation bioassay (<i>Echinometra mathaei</i>)	EC ₁₀									13.7
	EC ₅₀									19.8
	NOEC									6.3
	LOEC									12.5
5-7 day Copepod Larval Development Bioassay (<i>Gladioferens imparipes</i>)	EC ₁₀									2.9
	EC ₅₀									3.6
	NOEC									3.1
	LOEC									6.3
7-day fish larval development bioassay (<i>Seriola lalandi</i>)	EC ₁₀						3.21	3.38	16.3	2.0
	EC ₅₀						5.81	5.73	28.3	3.4
	NOEC						<3.1	3.1	6.3	<1.6
	LOEC						3.1	6.3	12.5	1.6
Level of species protection	95%	-	-	-	1.94	3.15	0.59	screening assessment indicated similar PFW toxicity to 2017 result	1.8	screening assessment indicated a PFW toxicity higher than 2019 result
	99%	-	-	-	1.48	2.17	0.39		1.3	
¹ 95% confidence limits are not reliable				EC ₅₀	Concentration at which 50% of the population's larval growth is affected					
² Graphical Method				LC ₅₀	Concentration at which 50% of the species population is affected					
³ TSK trim value = 0.0%				LOEC	Lowest possible concentration that may cause an adverse effect					
				NOEC	Concentration where no effect is observed					

Table 1-8 Results of TIE assessment

Treatment	Baseline	Zeolite	Ammonia
72-hour sea urchin larval development test using <i>Heliocidaris tuberculata</i>	4.4 (4.36-4.46)%	17.4 (17.17-17.67)%	N/A
Toxicity Units (TU)	22.7	5.7	17



APPENDIX 4

PFW Composition and Discharge Modelling Results

2. PFW DISCHARGE MODELLING RESULTS

2.1 Diluton Extents

Table 2-1 Comparison of the results between the 33,500 m³/day and 37,500 m³/day PFW flow rates during summer conditions (95th percentile)

Summer (January)				33,500 kL/day		37,500 kL/day	
Specific Criteria	Initial Conc.	Final Conc. (Threshold)	Dilutions	Max Horizontal Distance (km)	Area of exposure (km ²)	Max Horizontal Distance (km)	Area of exposure (km ²)
Whole Effluent (PC99)	100%	0.39%	256	3.18	2.05	3.28	2.77
Dissolved Oil (ANZECC 99%)	2,400ppb	16ppb	150	2.57	0.49		
	4,400ppb		275	3.26	2.64		
	2,160ppb		136			2.58	0.53
	3,900ppb		244			3.25	2.59
Dispersed Oil (PNEC)	12,000ppb	70.5ppb	170	2.84	0.72		
	22,000ppb		312	3.35	3.71		
	10,800ppb		153			2.83	0.69
	19,500ppb		277			3.34	3.65
Ammonia (ANZECC 99%)	42 mg/L	0.5 mg/L	84	0.49	0.07	0.69	0.10
Generic Zones of Dilution			15	-	-	0.01	0.0001
			25	0.02	0.0008	0.02	0.0011
			32	0.03	0.0021	0.05	0.0029
			100	0.73	0.12	0.96	0.17
			200	3.07	1.15	3.16	1.55



APPENDIX 4

PFW Composition and Discharge Modelling Results

Table 2-2 Comparison of the results between the 33,500 m³/day and 37,500 m³/day PFW flow rates during transitional conditions (95th percentile)

Transitional (April)				33,500 kL/day		37,500 kL/day	
Specific Criteria	Initial Conc.	Final Conc. (Threshold)	Dilutions	Max Horizontal Distance (km)	Area of exposure (km ²)	Max Horizontal Distance (km)	Area of exposure (km ²)
Whole Effluent (PC99)	100%	0.39%	256	2.47	1.86	2.98	2.56
Dissolved Oil (ANZECC 99%)	2,400ppb	16ppb	150	0.90	0.40		
	4,400ppb		275	2.94	2.44		
	2,160ppb		136			0.95	0.44
	3,900ppb		244			2.92	2.40
Dispersed Oil (PNEC)	12,000ppb	70.5ppb	170	1.16	0.60		
	22,000ppb		312	3.36	3.46		
	10,800ppb		153			1.12	0.58
	19,500ppb		277			3.35	3.41
Ammonia (ANZECC 99%)	42 mg/L	0.5 mg/L	84	0.28	0.05	0.32	0.08
Generic Zones of Dilution			15	-	-	-	-
			25	0.02	0.0003	0.02	0.0007
			32	0.02	0.0013	0.04	0.0018
			100	0.44	0.10	0.55	0.14
			200	1.57	0.96	2.01	1.35



APPENDIX 4

PFW Composition and Discharge Modelling Results

Table 2-3 Comparison of the results between the 33,500 m³/day and 37,500 m³/day PFW flow rates during winter conditions (95th percentile)

Winter (July)				33,500 kL/day		37,500 kL/day	
Specific Criteria	Initial Conc.	Final Conc. (Threshold)	Dilutions	Max Horizontal Distance (km)	Area of exposure (km ²)	Max Horizontal Distance (km)	Area of exposure (km ²)
Whole Effluent (PC99)	100%	0.39%	256	3.65	2.73	3.68	3.50
Dissolved Oil (ANZECC 99%)	2,400ppb	16ppb	150	1.70	0.58		
	4,400ppb		275	3.67	3.36		
	2,160ppb		136			1.84	0.65
	3,900ppb		244			3.67	3.31
Dispersed Oil (PNEC)	12,000ppb	70.5ppb	170	2.16	0.88		
	22,000ppb		312	3.73	4.50		
	10,800ppb		153			2.12	0.85
	19,500ppb		277			3.73	4.43
Ammonia (ANZECC 99%)	42 mg/L	0.5 mg/L	84	0.40	0.08	0.55	0.12
Generic Zones of Dilution			15	-	-	0.01	0.0001
			25	0.02	0.0008	0.02	0.0011
			32	0.03	0.0020	0.05	0.0031
			100	0.58	0.14	0.83	0.21
			200	3.13	1.51	3.59	2.11



APPENDIX 4

PFW Composition and Discharge Modelling Results

2.2 Whole Effluent frequency and duration analysis

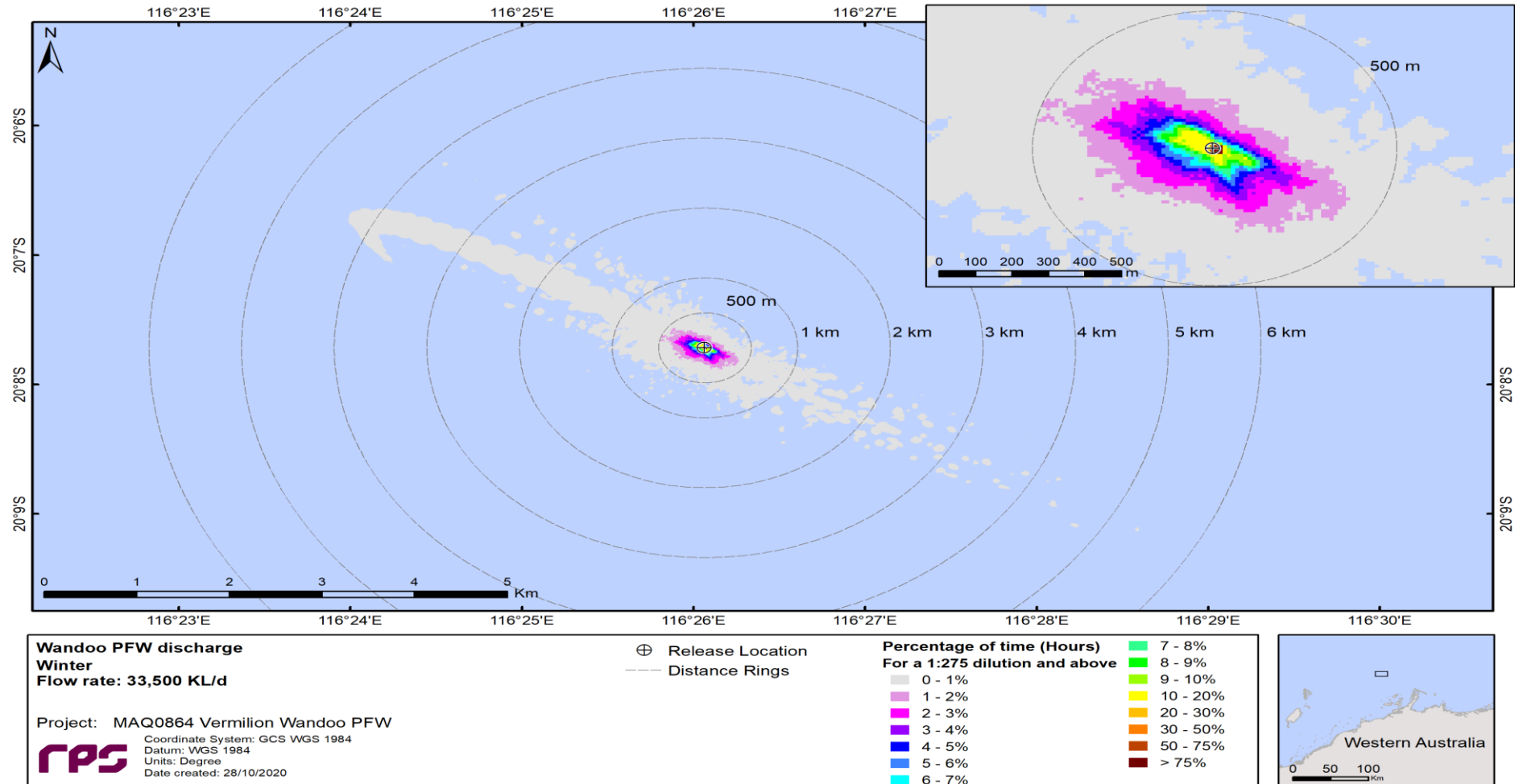

Figure 2-1 Spatial plots of percentage of time (hours) the PFW stream concentration occurred at, or below, equivalent dilution of 1:275 for the whole PFW stream. Modelling based on a flow rate of 33,500 kL/d during winter (July) conditions.

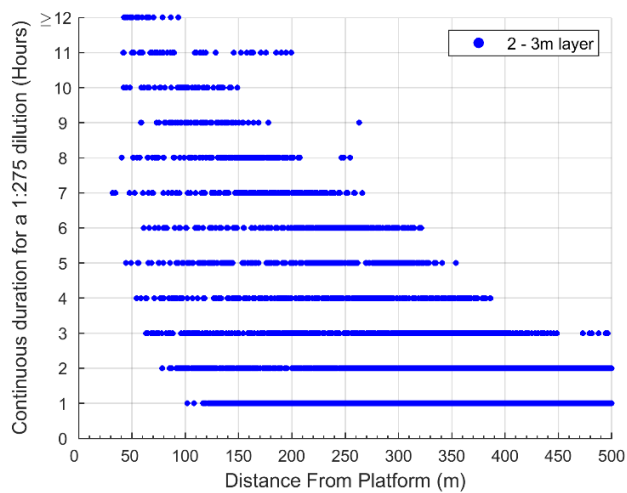
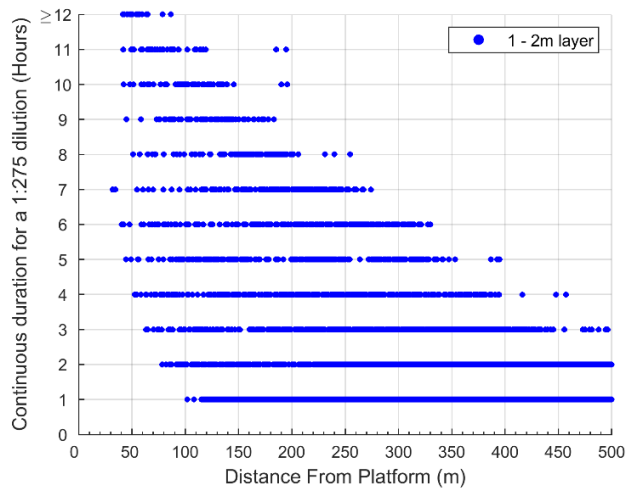
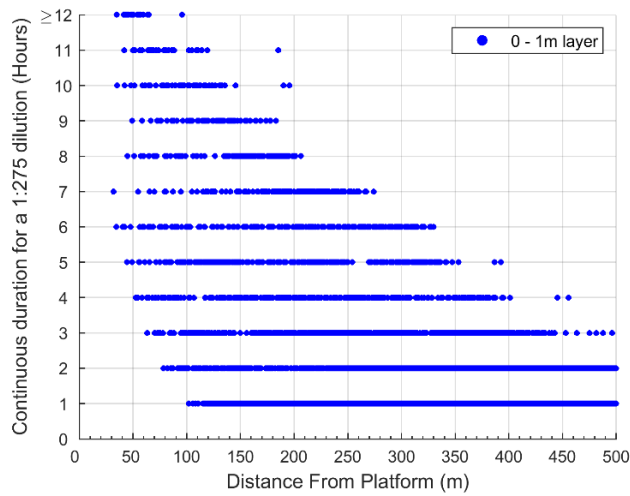

Figure 2-2 Scatter plots presenting the maximum continuous hours the PFW stream concentration occurred at, or below, equivalent dilution of 1:275 for the whole PFW stream. Modelling based on a flow rate of 33,500 kL/d during winter (July) conditions for the 0 – 1m (top plot), 1 – 2m (middle plot) and 2 – 3m depth layers (bottom plot)

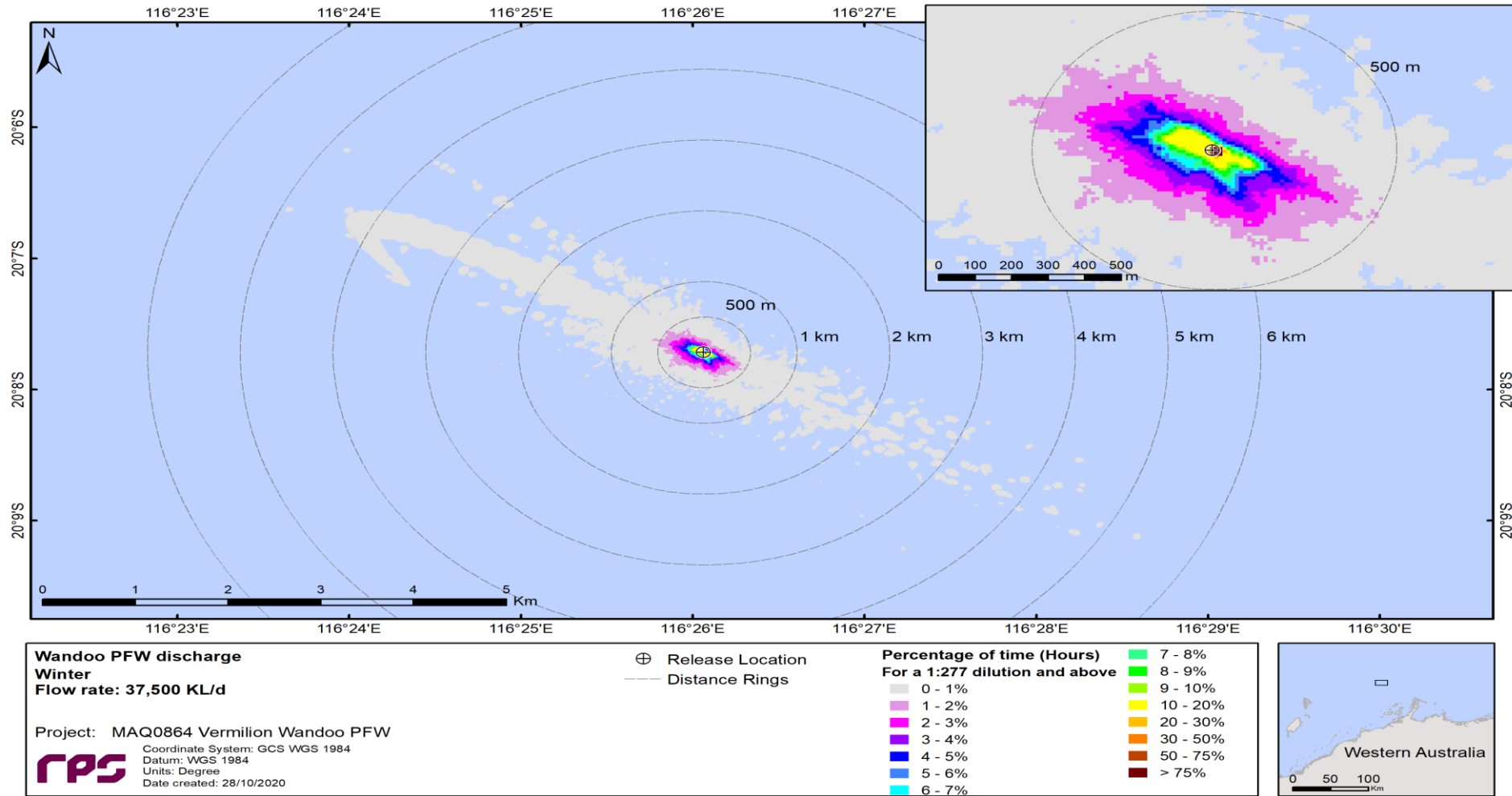

Figure 2-3 Spatial plots of percentage of time (hours) the PFW stream concentration occurred at, or below, equivalent dilution of 1:277 for the whole PFW stream. Modelling based on a flow rate of 37,500 kL/d during winter (July) conditions

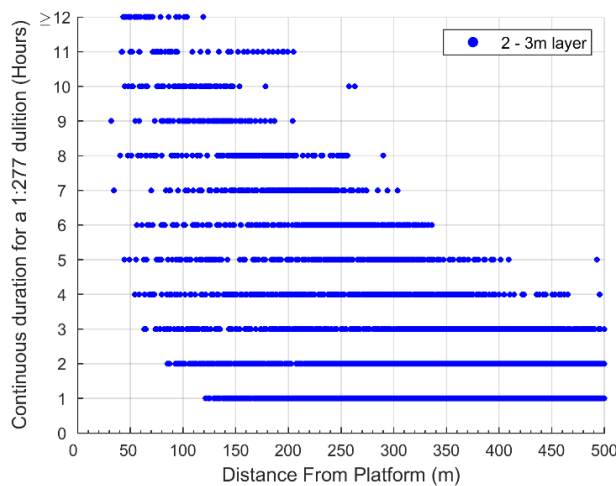
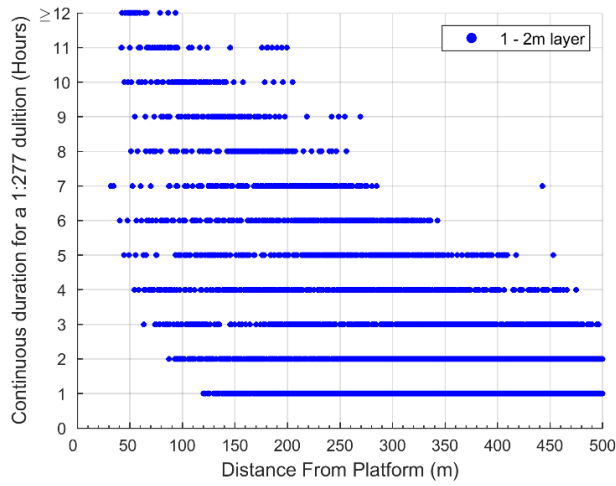
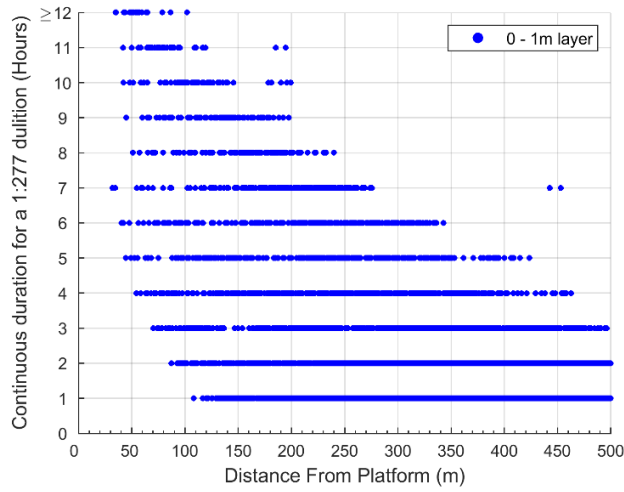

Figure 2-4 Scatter plots presenting the maximum continuous hours the PFW stream concentration occurred at, or below, equivalent dilution of 1:277 for the whole PFW stream. Modelling based on a flow rate of 37,500 kL/d during winter (July) conditions for the 0 – 1m (top plot), 1 – 2m (middle plot) and 2 – 3m depth layers (bottom plot)



2.3 Hydrocarbon frequency and duration analysis

2.3.1 *Dissolved Oil*

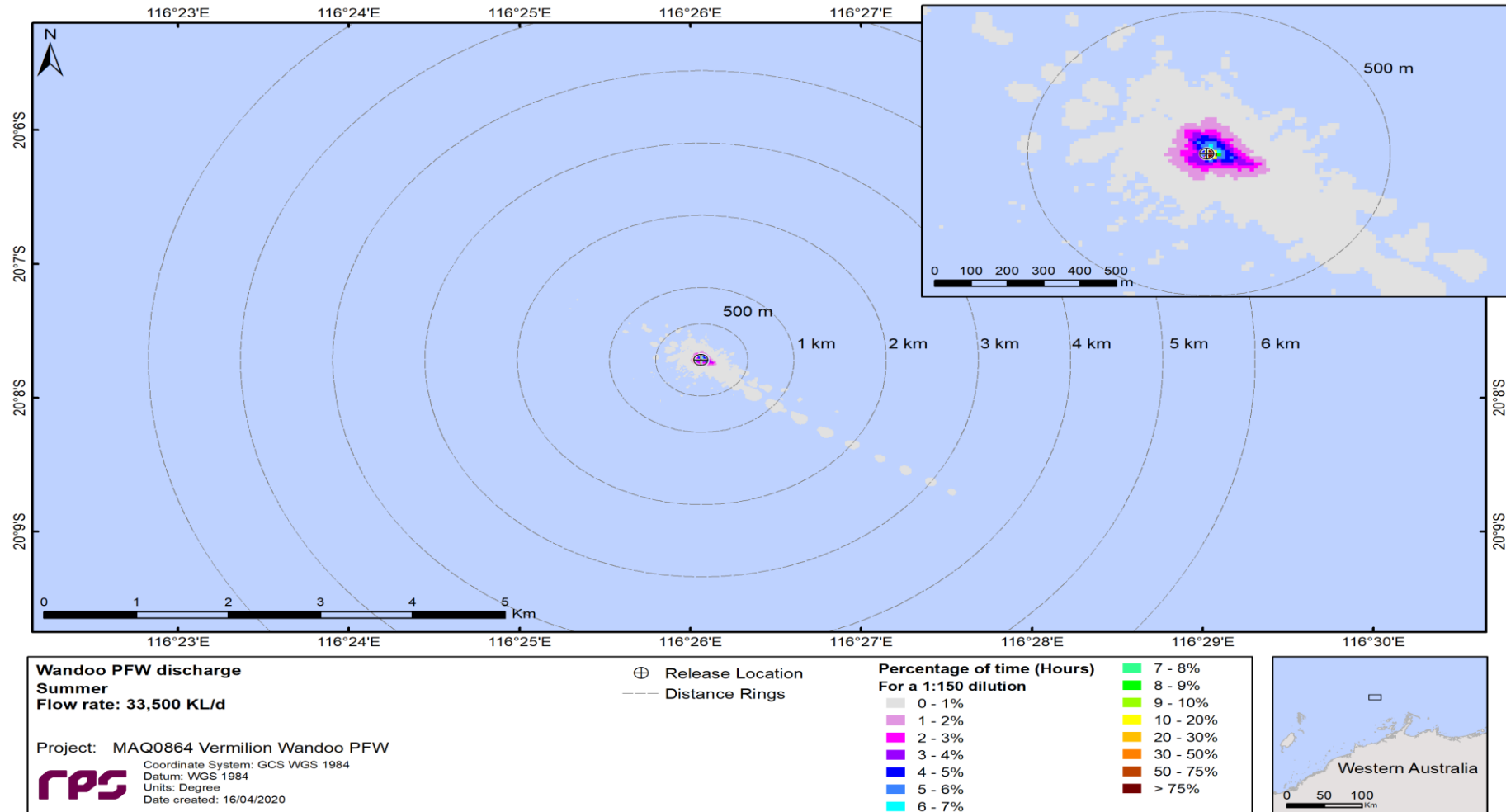

Figure 2-5 Spatial plots of percentage of time (hours) the PFW stream concentration occurred at, or below, equivalent dilution of 1:150 for the whole PFW stream. Modelling based on a flow rate of 33,500 kL/d during summer (January) conditions.

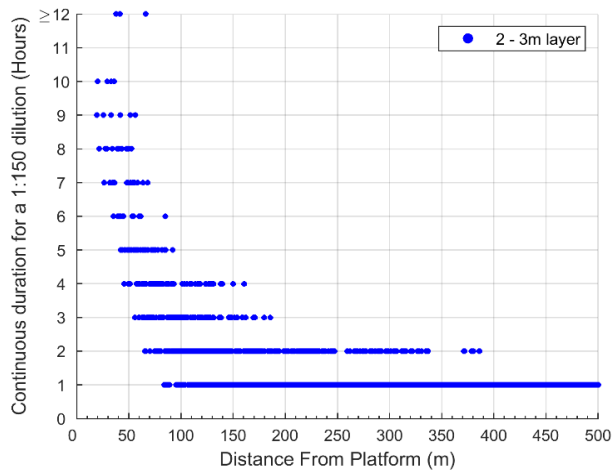
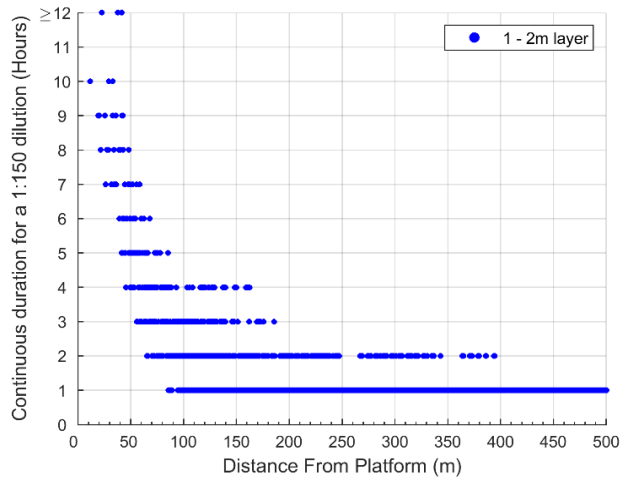
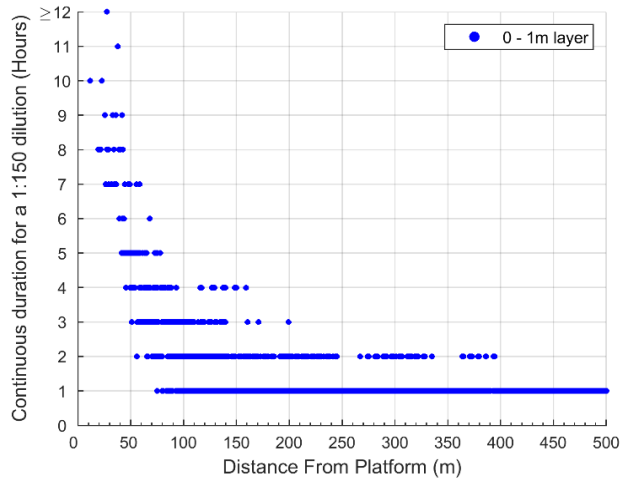

Figure 2-6 Scatter plots presenting the maximum continuous hours the PFW stream concentration occurred at, or below, equivalent dilution of 1:150 for the whole PFW stream. Modelling based on a flow rate of 33,500 kL/d during summer (January) conditions for the 0 – 1m (top plot), 1 – 2m (middle plot) and 2 – 3m depth layers (bottom plot)

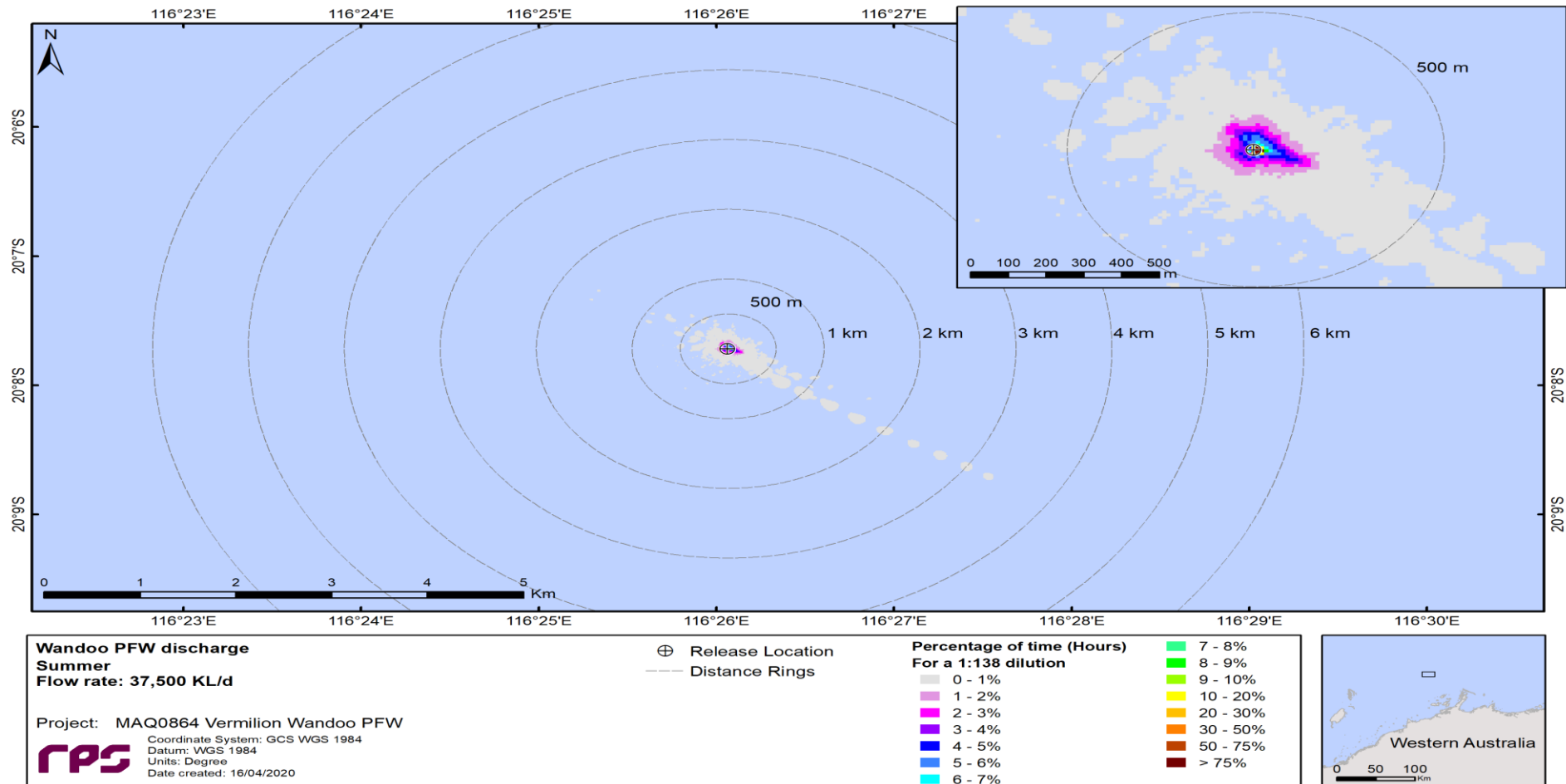

Figure 2-7 Spatial plots of percentage of time (hours) the PFW stream concentration occurred at, or below, equivalent dilution of 1:138 for the whole PFW stream. Modelling based on a flow rate of 37,500 kL/d during summer (January) conditions.

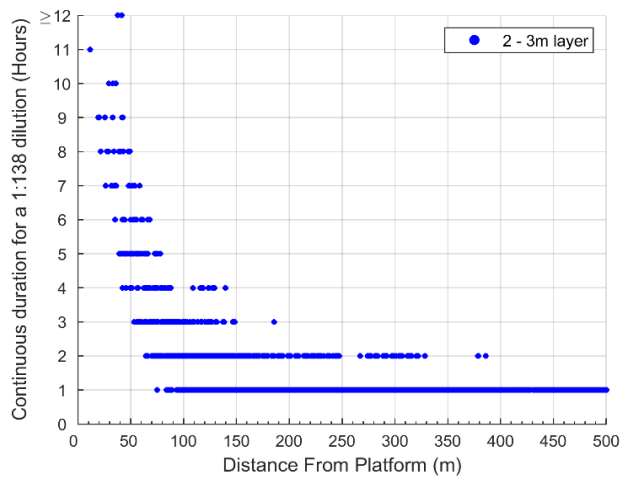
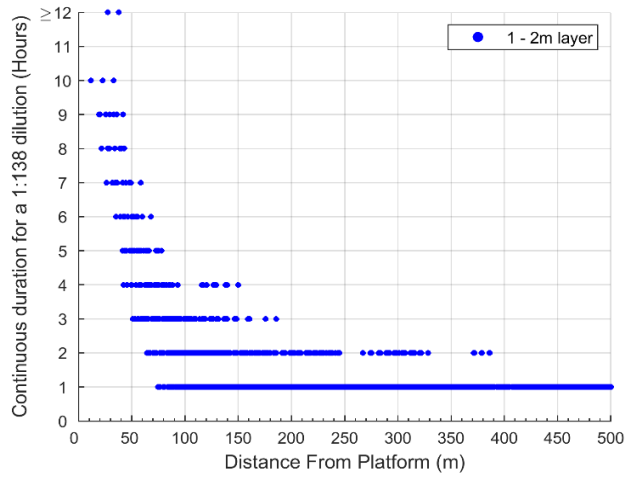
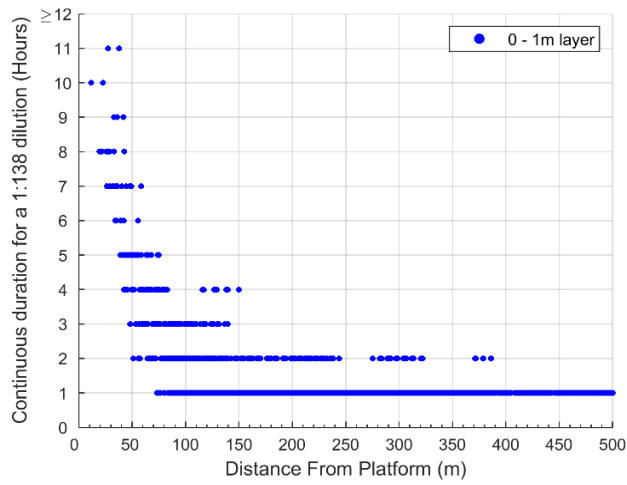

Figure 2-8 Scatter plots presenting the maximum continuous hours the PFW stream concentration occurred at, or below, equivalent dilution of 1:138 for the whole PFW stream. Modelling based on a flow rate of 37,500 kL/d during summer (January) conditions for the 0 – 1m (top plot), 1 – 2m (middle plot) and 2 – 3m depth layers (bottom plot)

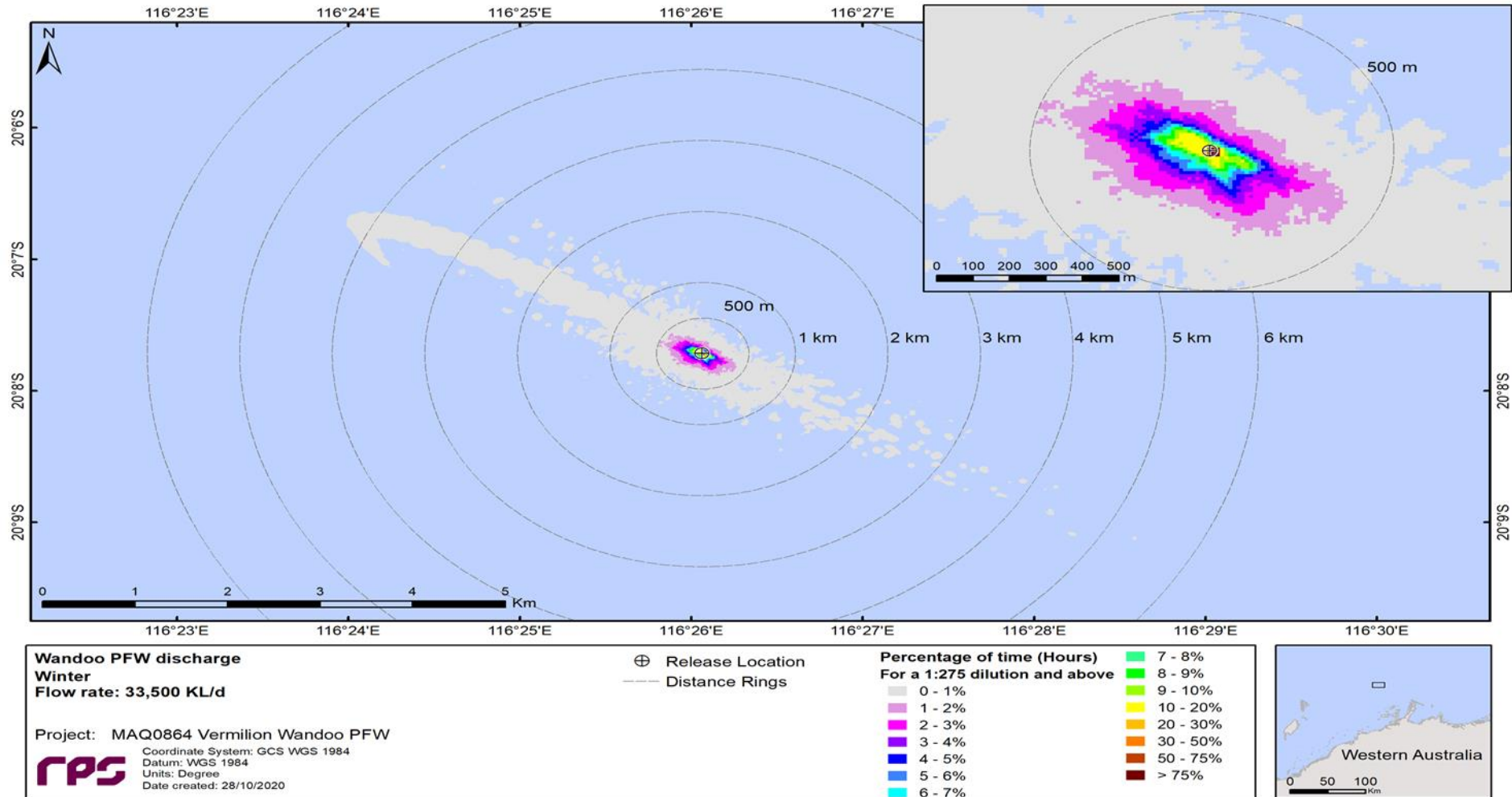

Figure 2-9 Spatial plots of percentage of time (hours) the PFW stream concentration occurred at, or below, equivalent dilution of 1:275 for the whole PFW stream. Modelling based on a flow rate of 33,500 kL/d during winter (July) conditions.

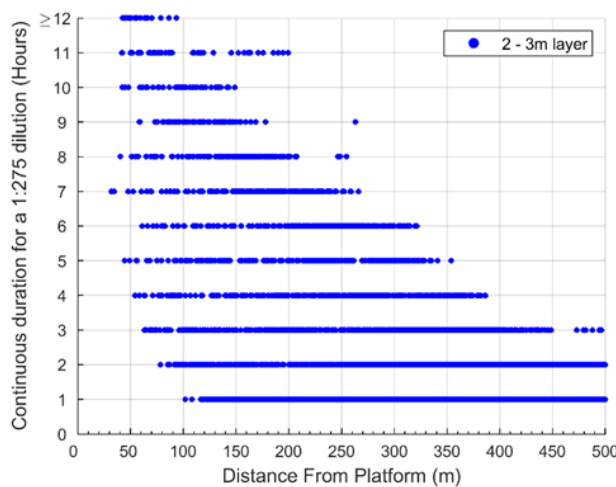
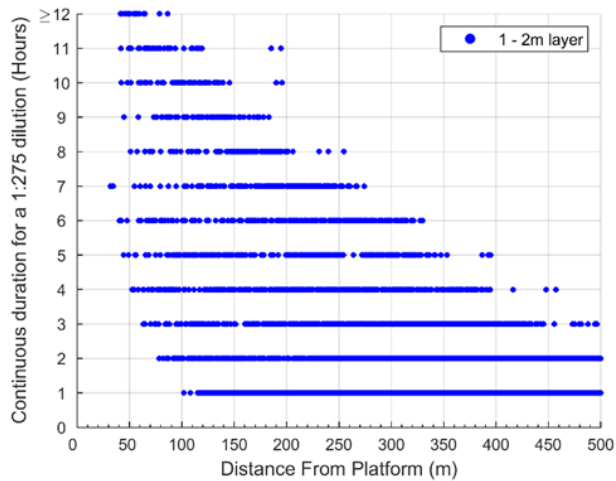
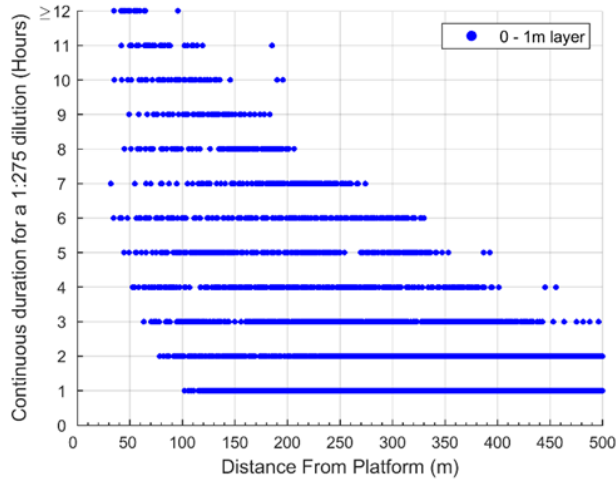

Figure 2-10 Scatter plots presenting the maximum continuous hours the PFW stream concentration occurred at, or below, equivalent dilution of 1:275 for the whole PFW stream. Modelling based on a flow rate of 33,500 kL/d during winter (July) conditions for the 0 – 1m (top plot), 1 – 2m (middle plot) and 2 – 3m depth layers (bottom plot)

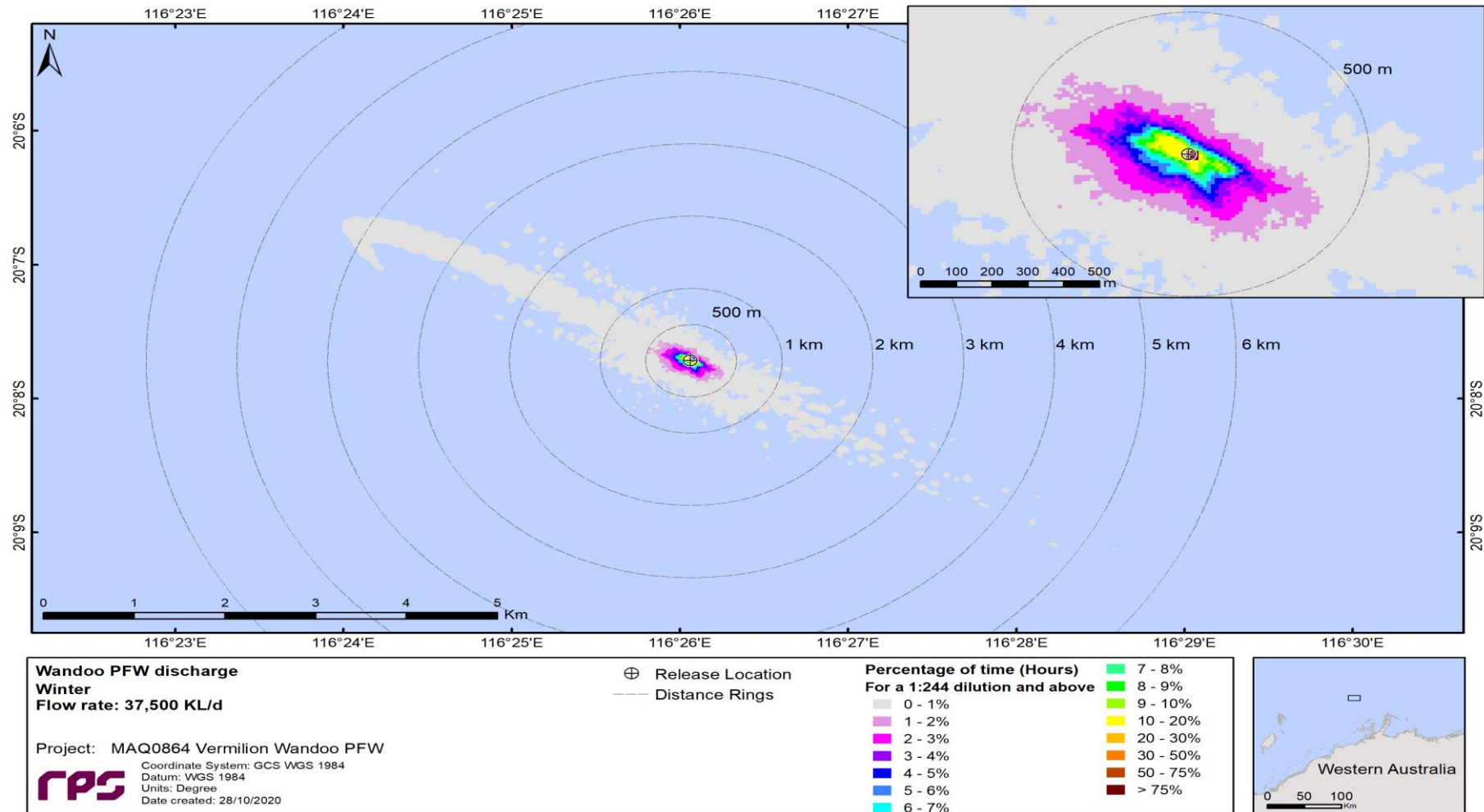

Figure 2-11 Spatial plots of percentage of time (hours) the PFW stream concentration occurred at, or below, equivalent dilution of 1:244 for the whole PFW stream. Modelling based on a flow rate of 37,500 kL/d during summer (January) conditions

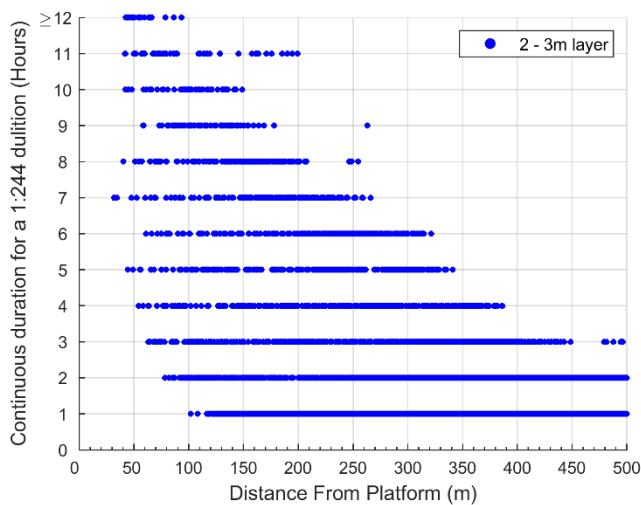
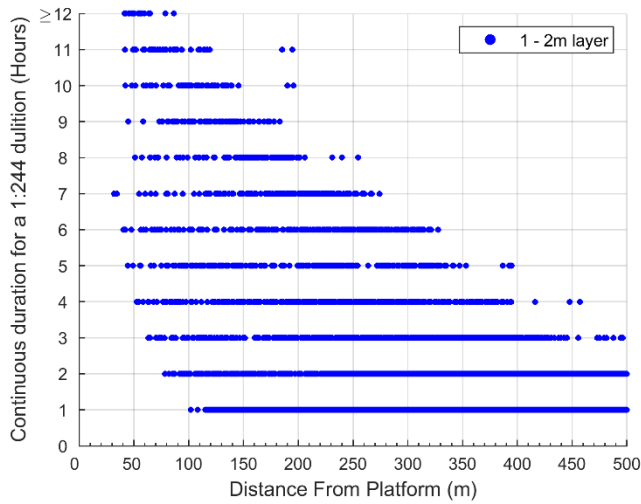
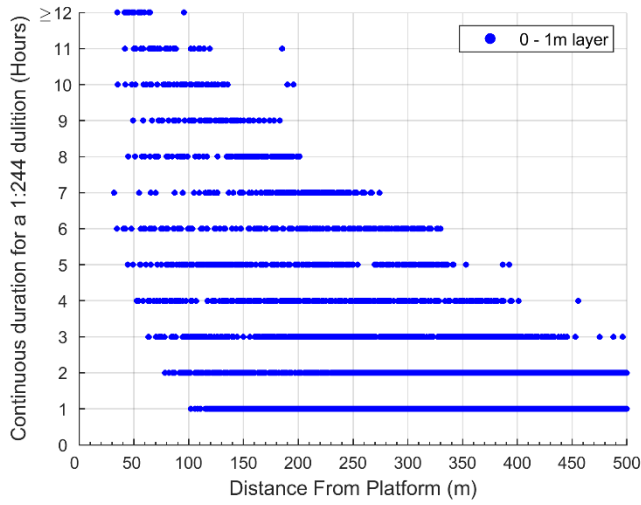

Figure 2-12 Scatter plots presenting the maximum continuous hours the PFW stream concentration occurred at, or below, equivalent dilution of 1:244 for the whole PFW stream. Modelling based on a flow rate of 33,500 kL/d during winter (July) conditions for the 0 – 1m (top plot), 1 – 2m (middle plot) and 2 – 3m depth layers (bottom plot)



APPENDIX 4

PFW Composition and Discharge Modelling Results

2.3.2 *Dispersed (Entrained) Oil*

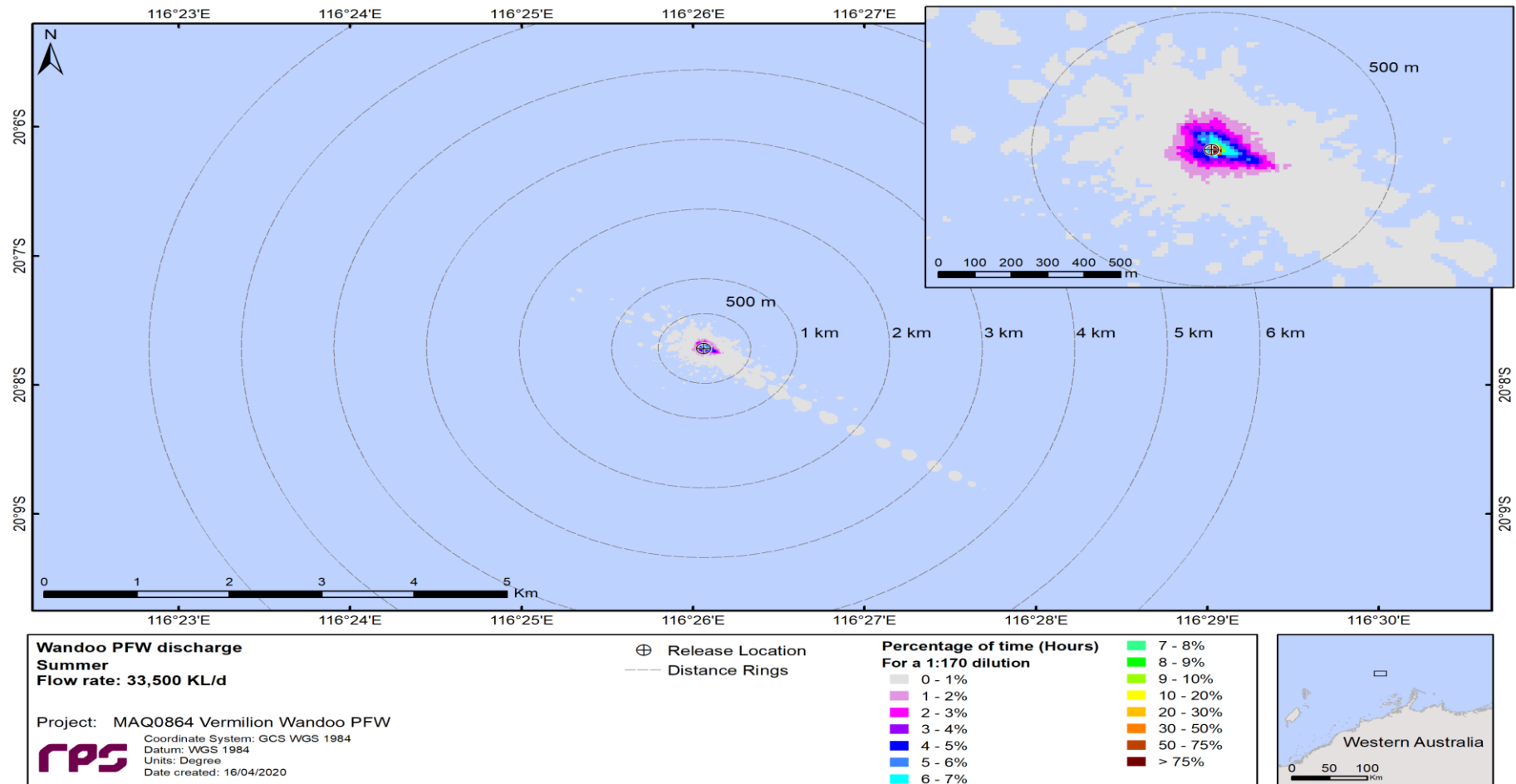

Figure 2-13 Spatial plots of percentage of time (hours) the PFW stream concentration occurred at, or below, equivalent dilution of 1:170 for the whole PFW stream. Modelling based on a flow rate of 33,500 kL/d during summer (January) conditions.

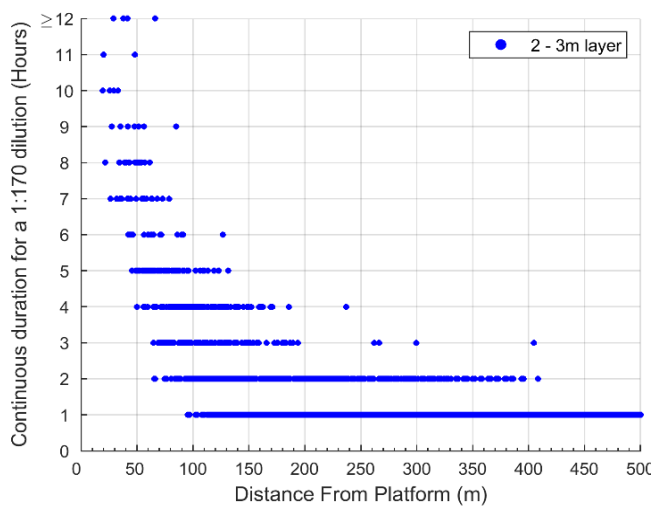
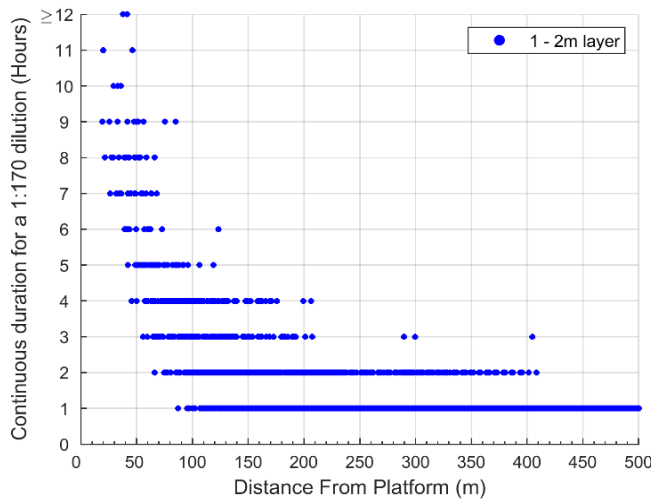
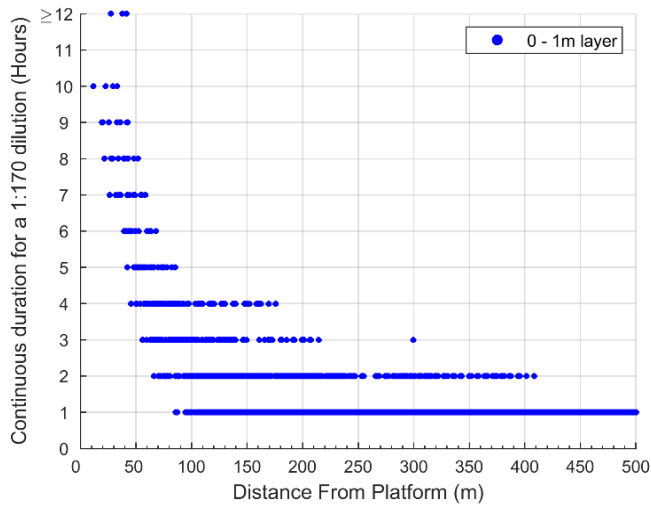

Figure 2-14 Scatter plots presenting the maximum continuous hours the PFW stream concentration occurred at, or below, equivalent dilution of 1:170 for the whole PFW stream. Modelling based on a flow rate of 33,500 kL/d during summer (January) conditions for the 0 – 1m (top plot), 1 – 2m (middle plot) and 2 – 3m depth layers (bottom plot)

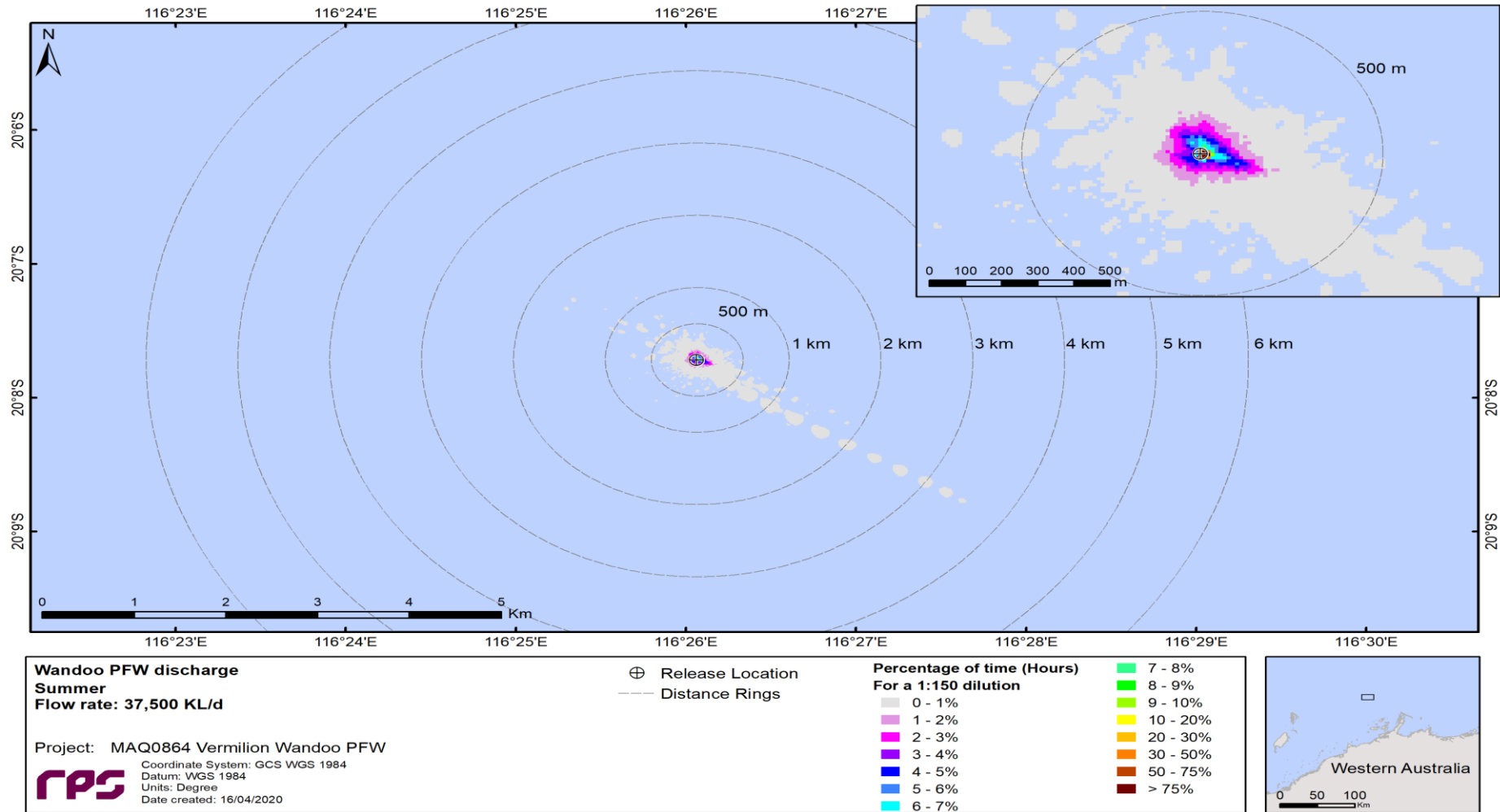

Figure 2-15 Spatial plots of percentage of time (hours) the PFW stream concentration occurred at, or below, equivalent dilution of 1:150 for the whole PFW stream. Modelling based on a flow rate of 37,500 kL/d during summer (January) conditions.

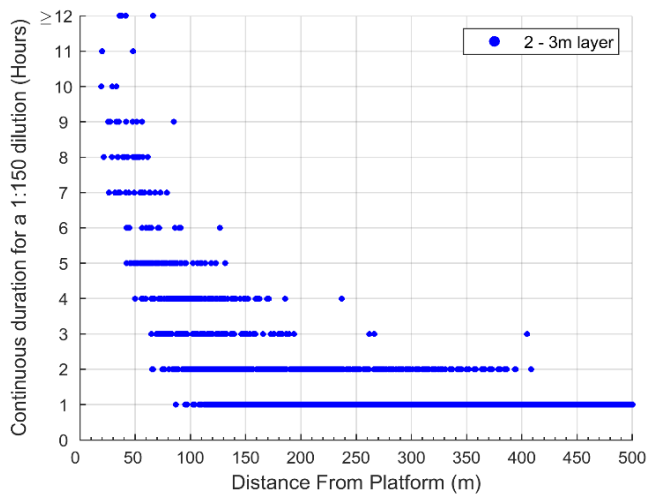
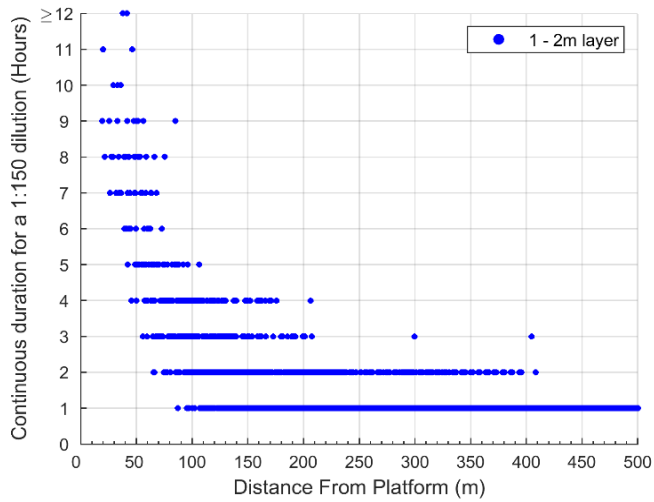
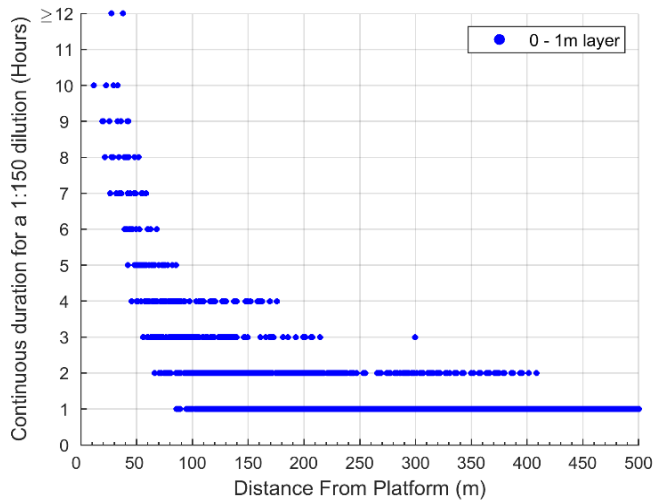

Figure 2-16 Scatter plots presenting the maximum continuous hours the PFW stream concentration occurred at, or below, equivalent dilution of 1:150 for the whole PFW stream. Modelling based on a flow rate of 37,500 kL/d during summer (January) conditions for the 0 – 1m (top plot), 1 – 2m (middle plot) and 2 – 3m depth layers (bottom plot).

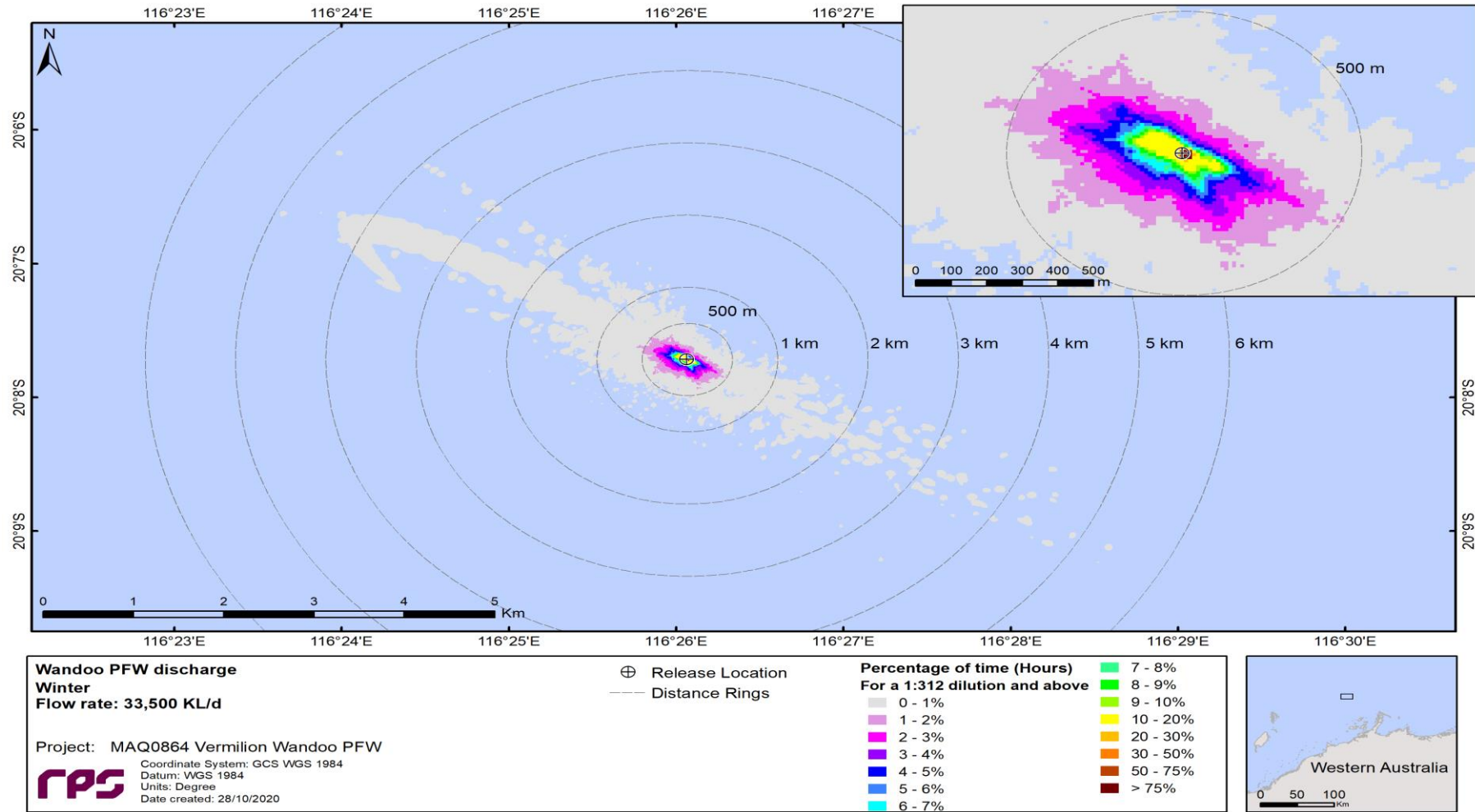

Figure 2-17 Spatial plots of percentage of time (hours) the PFW stream concentration occurred at, or below, equivalent dilution of 1:312 for the whole PFW stream. Modelling based on a flow rate of 33,500 kL/d during winter(July) conditions

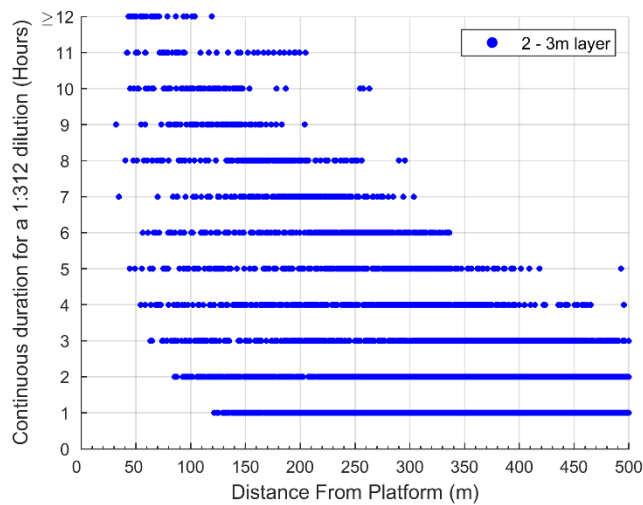
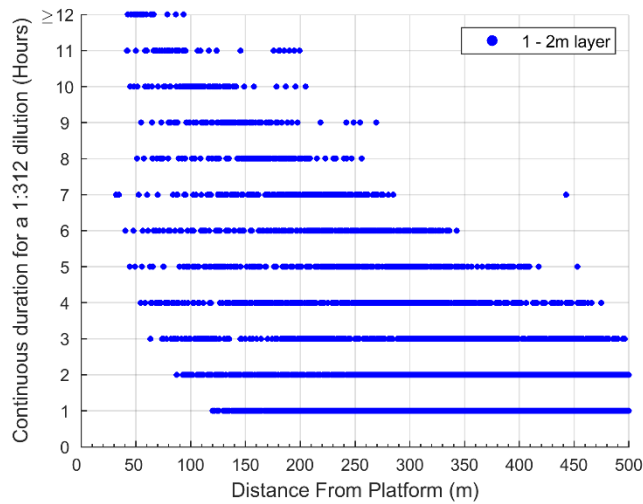
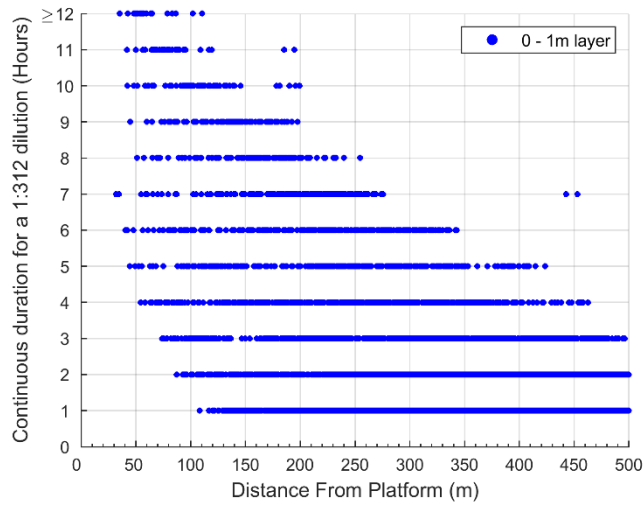

Figure 2-18 Scatter plots presenting the maximum continuous hours the PFW stream concentration occurred at, or below, equivalent dilution of 1:312 for the whole PFW stream. Modelling based on a flow rate of 33,500 kL/d during winter (July) conditions for the 0 – 1m (top plot), 1 – 2m (middle plot) and 2 – 3m depth layers (bottom plot)

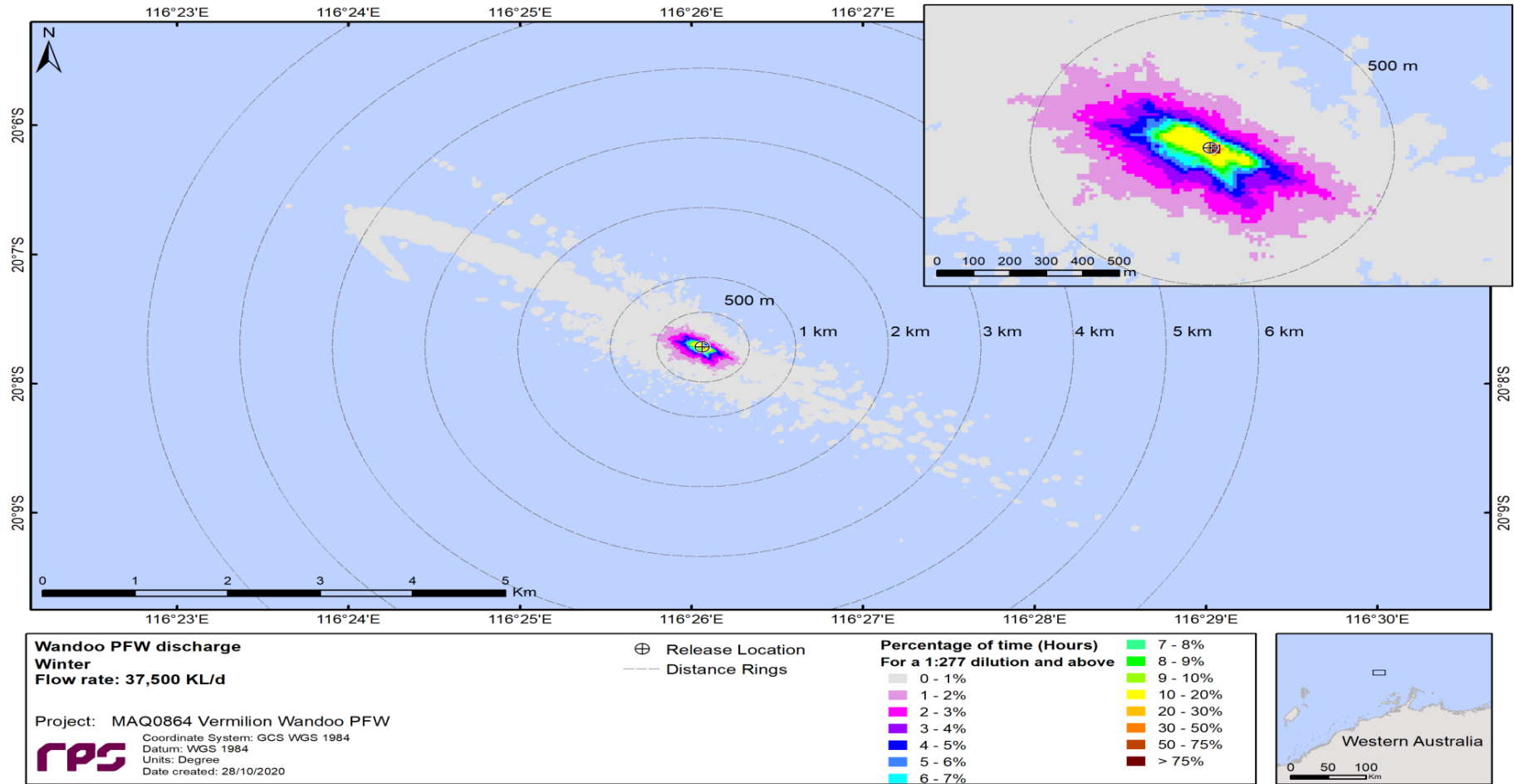

Figure 2-19 Spatial plots of percentage of time (hours) the PFW stream concentration occurred at, or below, equivalent dilution of 1:277 for the whole PFW stream. Modelling based on a flow rate of 37,500 kL/d during winter(July) conditions

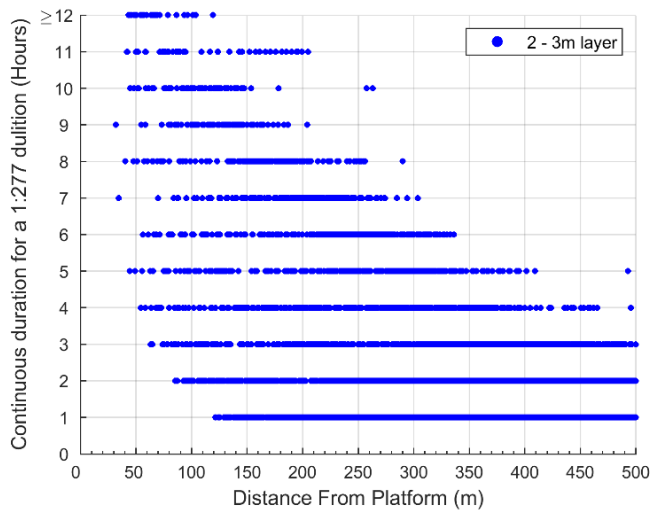
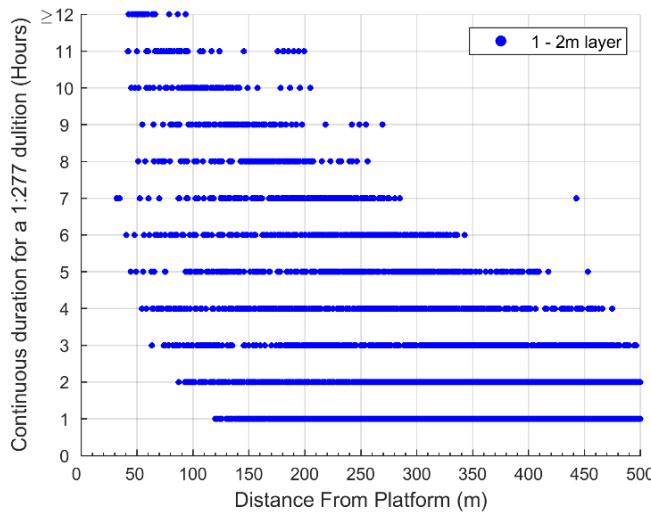
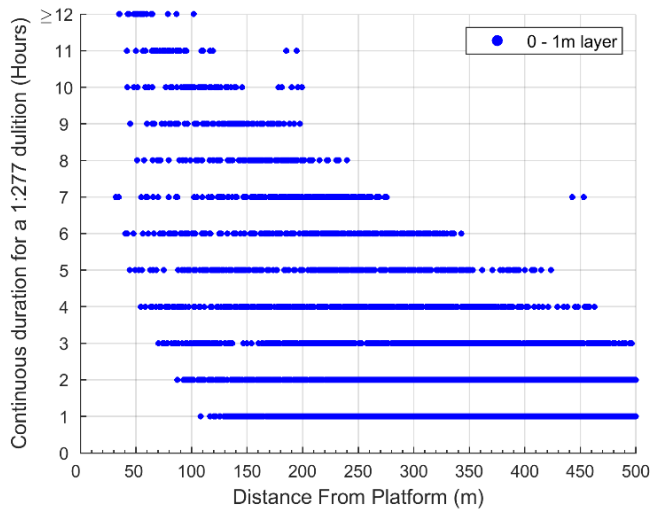

Figure 2-20 Scatter plots presenting the maximum continuous hours the PFW stream concentration occurred at, or below, equivalent dilution of 1:277 for the whole PFW stream. Modelling based on a flow rate of 37,500 kL/d during winter (July) conditions for the 0 – 1m (top plot), 1 – 2m (middle plot) and 2 – 3m depth layers (bottom plot)



APPENDIX 4

PFW Composition and Discharge Modelling Results

2.3 Ammonia frequency and duration analysis

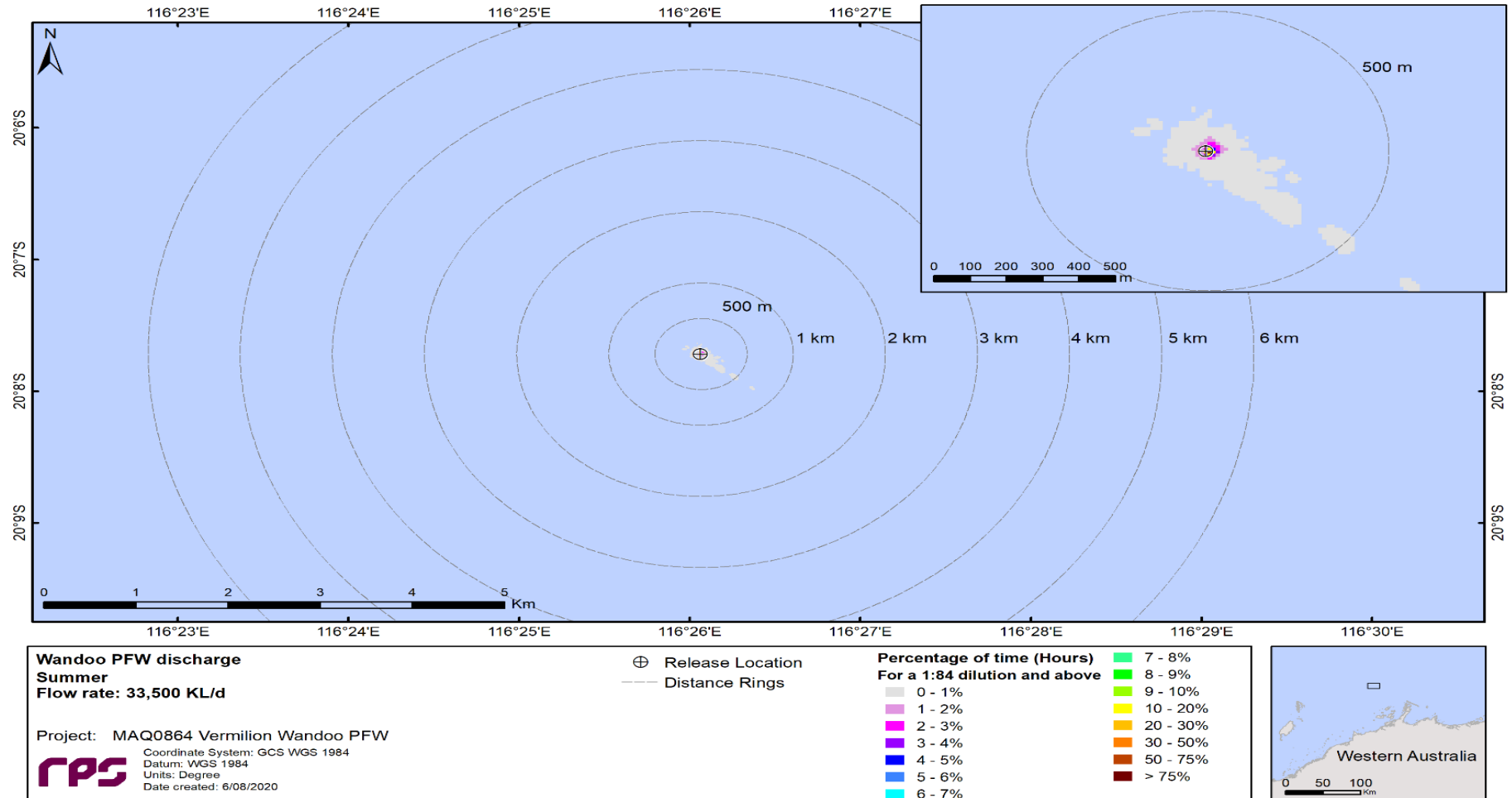

Figure 2-21 Spatial plots of percentage of time (hours) the PFW stream concentration occurred at, or below, equivalent dilution of 1:84 for the whole PFW stream. Modelling based on a flow rate of 33,500 kL/d during summer (January) conditions.

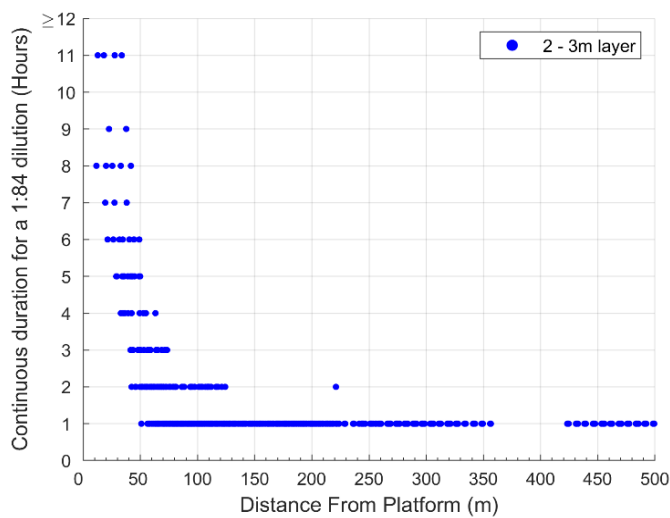
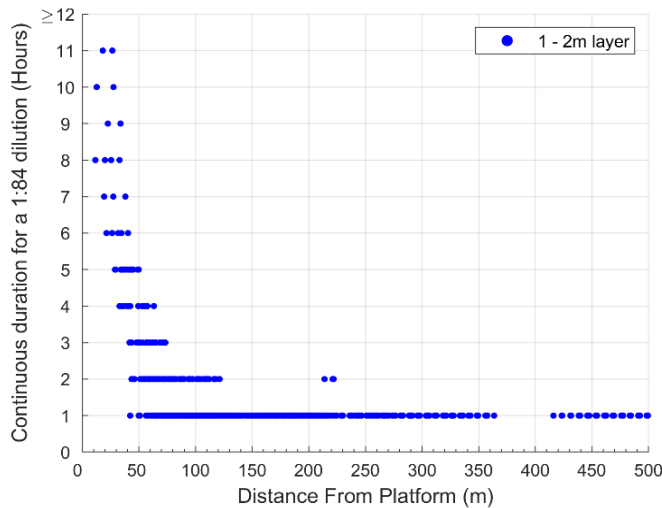
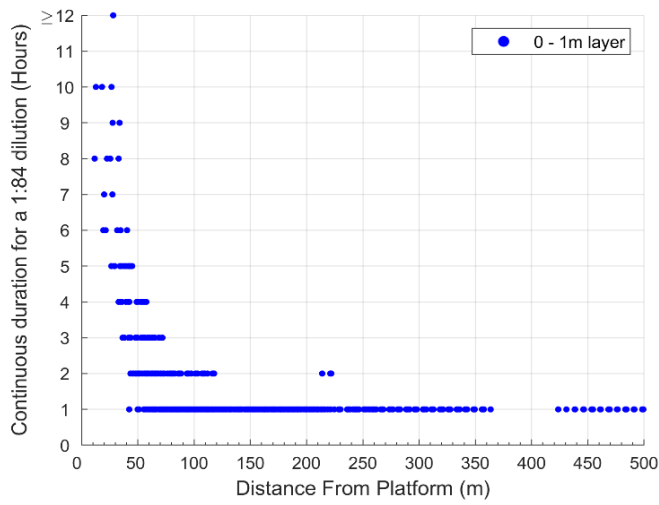

Figure 2-22 Scatter plots presenting the maximum continuous hours the PFW stream concentration occurred at, or below, equivalent dilution of 1:84 for the whole PFW stream. Modelling based on a flow rate of 33,500 kL/d during summer (January) conditions for the 0 – 1m (top plot), 1 – 2m (middle plot) and 2 – 3m depth layers (bottom plot).

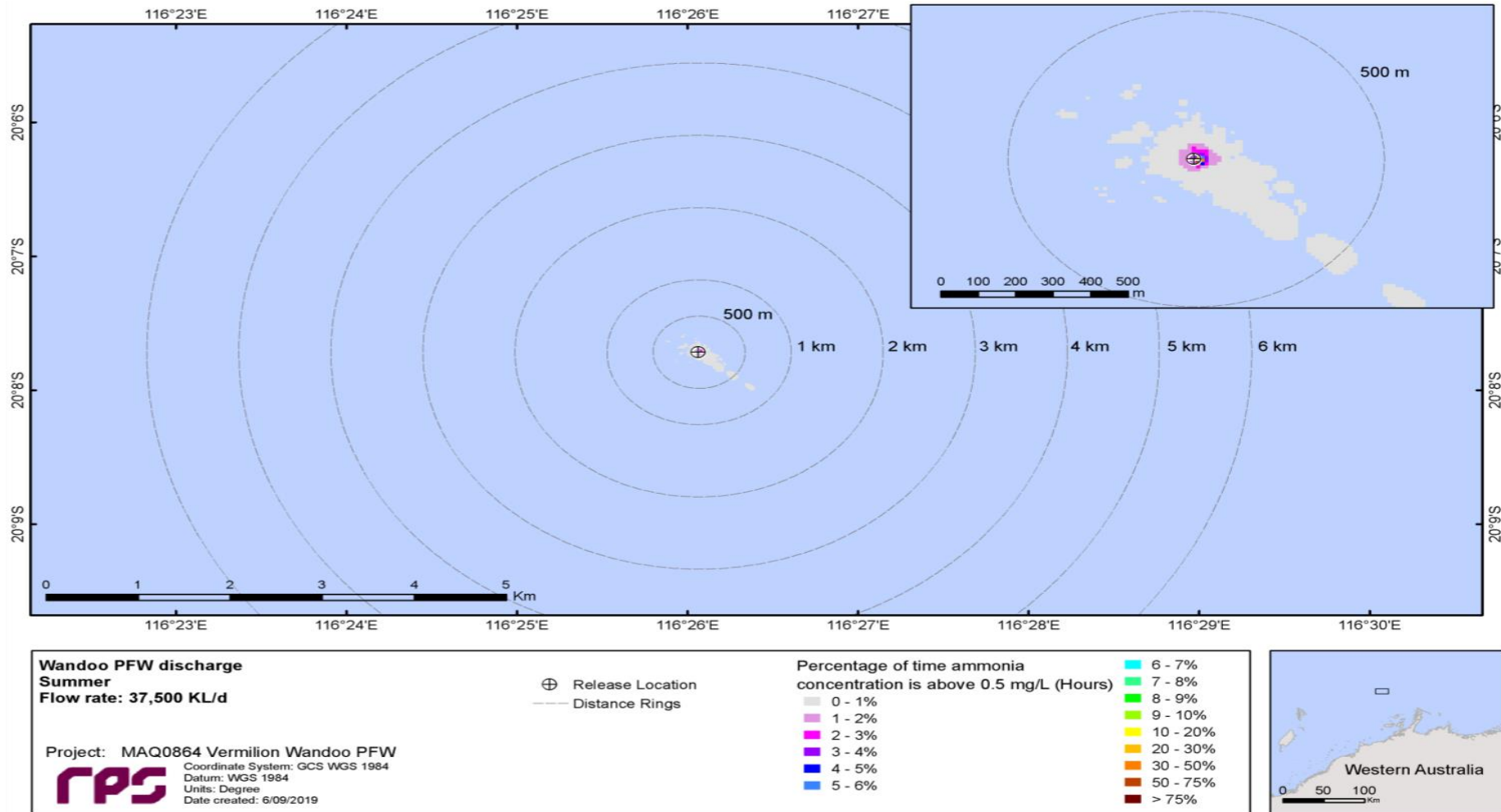

Figure 2-23 Spatial plots of percentage of time (hours) the PFW stream concentration occurred at, or below, equivalent dilution of 1:84 for the whole PFW stream. Modelling based on a flow rate of 37,500 kL/d during summer (January) conditions.

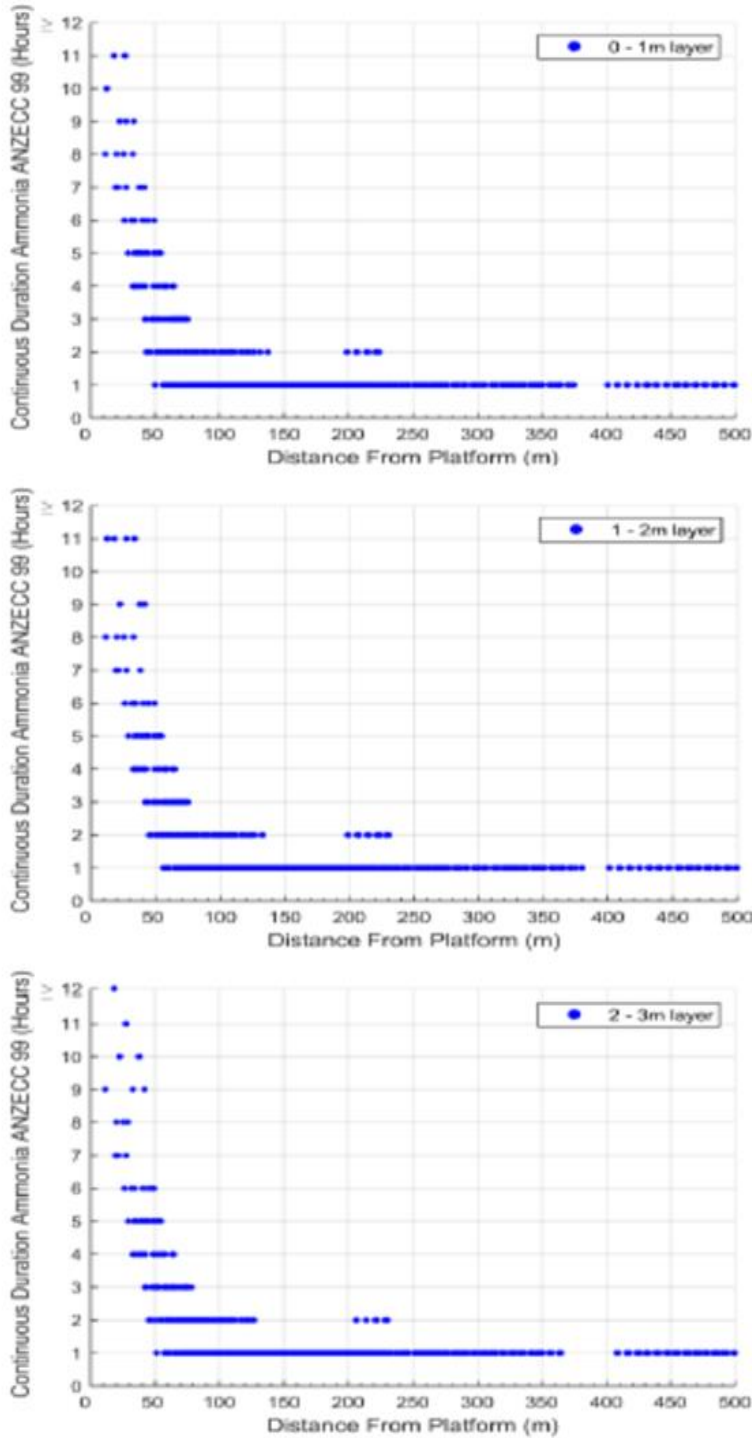

Figure 2-24 Scatter plots presenting the maximum continuous hours the PFW stream concentration occurred at, or below, equivalent dilution of 1:84 for the whole PFW stream. Modelling based on a flow rate of 37,500 kL/d during summer (January) conditions for the 0 – 1m (top plot), 1 – 2m (middle plot) and 2 – 3m depth layers (bottom plot).

Appendix 5: Performance Standards

Performance Standards

Applicable Performance Standards within the EP (in order):

WAN-WNAB-CE-PR-01 - HYDROCARBON CONTAINMENT (STATIC EQUIPMENT)

WAN-WNAB-CE-PR-02 - HYDROCARBON CONTAINMENT (WELLS)

WAN-WNAB-CE-PR-05 – LIFTING EQUIPMENT

WAN-WNAB-CE-PR-06 - NAVIGATION AIDS

WAN-WNAB-CE-PR-07 – STRUCTURAL INTEGRITY

WAN-WNAB-CE-DC-02 - INSTRUMENT PROTECTIVE AND ALARM SYSTEMS

WAN-WNAB-CE-DC-03 – SHUTDOWN VALVES

WAN-WNAB-CE-DC-07 - INTEGRATED CONTROL SYSTEM

WAN-WNAB-CE-ES-02 - EMERGENCY COMMUNICATIONS

WAN-WNAB-CP-PR-04 – INTEGRITY MANAGEMENT

WAN-WNAB-CP-PR-06 – WELL CONTROL

WAN-WNAB-CP-ER-01 – EMERGENCY PREPAREDNESS, MANAGEMENT & RESPONSE

WAN-WNAB-CP-ER-02 & WAN-WNAB-CP-ER-03 – OIL SPILL RESPONSE



TITLE: HYDROCARBON CONTAINMENT (STATIC EQUIPMENT) **DOC ID:** WAN-WNAB-CE-PR-01 **RESPONSIBLE:** FACILITY ENGINEER

SAFETY GOAL:	Prevention
OBJECTIVE:	To prevent loss of containment of hydrocarbons from Static Equipment (flowlines, risers, piping, pressure vessel) sufficient to result in an MAE or CEE
MAEs & CEEs:	MAE-02, MAE-03 and CEE-03
SCOPE:	<p>Inclusions:</p> <ul style="list-style-type: none"> Interfield Gas Flowline between WNB RSDV (11-RSDV-5426) and WNA RSDV (14-SDV-1078), including two carbon steel rigid risers, subsea flexible flowline, and supporting structures. All process pipework and Fixed Pressure Vessels in Hydrocarbon Service whose failure could result in an MAE. <ul style="list-style-type: none"> On WNA – includes flammable isolatable inventories as described in Table 1 below [3]. On WNB – includes flammable isolatable inventories as described in Table 2 below [2]. Concrete Gravity Structure Storage Caissons (Storage Cells 1 & 2) – environmentally critical function only <p>Exclusions:</p> <ul style="list-style-type: none"> Shut down valves are covered under WAN-WNAB-CE-DC-03 Blowdown valves considered under WAN-WNAB-CE-DC-04 Flame arrest devices covered under WAN-WNAB-CE-DC-05 Pressure relief devices covered under WAN-WNAB-CE-PR-04 Instrumentation connected to hydrocarbon equipment associated with protective and alarm systems is covered under WAN-WNAB-CE-DC-02 Atmospheric tanks (for example rundown/export caissons, oil storage cells, recovered oil tank, ISFU) are not safety critical as there are no MAEs associated with releases from these inventories [2][3]. Note, however, that these still have non-critical environmental performance requirements. Static equipment not within the bounds described in Tables 1 & 2 below (including non-hydrocarbon pressure equipment with a Hazard Level of B or higher as defined by AS 4343) do not have any associated MAEs related to loss of containment and are therefore not considered safety critical. Note, however, that some of these still have non-critical environmental performance requirements.

FUNCTIONALITY

Key Component	Key Requirement	Performance Criteria	Assurance Activity	Minimum Frequency	Assurance Task	Reference
WAN-WNAB-CE-PR-01-01.01 Gas Flowline (subsea)	Gas flowline shall contain pressurised hydrocarbons	• There shall be no visible damage to the outer sheath	• Visual Inspection	24M	IN-SS-IN-48; (PS-022)	[1][4]
		• There shall be no over-bending of the flowline.	• Visual Inspection	24M	IN-SS-IN-48; (PS-022)	[1][4]
		• There shall be no evidence of gas leaking from the flowline (except from fitted gas relief valves), at more than one bubble per minute.	• Visual Inspection	24M	IN-SS-IN-48; (PS-022)	[1][4]
WAN-WNAB-CE-PR-01-01.02 Gas Risers	Risers shall contain pressurised hydrocarbons	• The Wall Thickness of risers shall be sufficient to satisfy fitness for service	• Non-Intrusive Inspection (NII)	48M	INT-0002; (PS-023)	[1][4][5][8][9]
WAN-WNAB-CE-PR-01-01.03 Gas Riser Supports	Riser supports shall resist normal operating, extreme, and accidental loading conditions	• Riser supports display no visible damage or deterioration and no air gaps with the pipework	• Visual Inspection	48M	IN-SS-IN-48; (PS-022)	[1][4][5][8]
WAN-WNAB-CE-PR-01-02 Pipework & Pressure Vessels	Pipework and pressure vessels shall contain pressurised hydrocarbons	• There shall be no hydrocarbon leaks	• Ongoing Ops / Maintenance presence on platform	N/A	N/A	[1]
		• Cracks or crack-like defects shall be below the critical size so as to satisfy fitness for service	• Visual Inspection &/or Non-Intrusive Inspection (NII)	48M	A0001970; 99855mik A0001972; 99857min A0001973; 99858min	[1][5][6][7][8][9]
		• The Wall Thickness shall be sufficient to satisfy fitness for service	• Non-Intrusive Inspection (NII)	48M	A0001970; 99855mik A0001972; 99857min A0001973; 99858min	[1][5][6][7][8][9]
		• Supports display no visible damage or deterioration and no air gaps with the equipment supported	• Visual Inspection	24M	A0001970; 99855mik A0001972; 99857min A0001973; 99858min	[1][5][7][8]
WAN-WNAB-CE-PR-01-03 CGS Storage Caissons	CGS shall contain hydrocarbons	• Temperature of liquids within CGS are to be maintained within 18°C of the ambient sea temperature	• Ongoing monitoring via protective instrumentation	N/A	Refer DC-02	
		• Physical condition and anomalous effects shall remain within acceptable limits.	• Visual Inspection • Non-Intrusive Inspection	60M	Refer PR-07	

AVAILABILITY / RELIABILITY

Key Component	Key Requirement	Performance Criteria	Assurance Activity	Minimum Frequency	Assurance Task	Reference
WAN-WNB-CE-PR-01-01.01 & WAN-WNB-CE-PR-01-01.02 Gas Flowline (subsea) & Gas Risers	System availability	• Functional criteria to be available 100% of the time when system is in service	• Ongoing Ops / Maintenance presence on platform	N/A	N/A	[1]
WAN-WNB-CE-PR-01-02 Pipework & Pressure Vessels	System availability	• Functional criteria to be available 100% of the time when system is in service and contains flammable hydrocarbons	• Ongoing Ops / Maintenance presence on platform	N/A	N/A	[1]
WAN-WNB-CE-PR-01-02 Pipework & Pressure Vessels	System availability	• An external hydrocarbon leak is defined as: ○ Gas: 20% LEL measured at 100mm from source ○ Liquid: 4 drips per minute, or 1 litre in 24 hrs	• N/A	N/A	N/A	[1]
WAN-WNB-CE-PR-01.03 CGS Storage Caissons	System availability	• Functional criteria to be available 100% of the time when system contains crude oil	• Ongoing Ops / Maintenance presence on platform	N/A	N/A	[1]
WAN-WNB-CE-PR-01 All Systems	System reliability	• No specific reliability criteria defined	• N/A	N/A	N/A	[1]



TITLE: HYDROCARBON CONTAINMENT (STATIC EQUIPMENT) DOC ID: WAN-WNAB-CE-PR-01 RESPONSIBLE: FACILITY ENGINEER

SURVIVABILITY						
Key Component	Key Requirement	Performance Criteria	Assurance Activity	Minimum Frequency	Assurance Task	Reference
WAN-WNB-CE-PR-01 All Systems	No specific survivability requirement.	• N/A	• N/A	N/A	N/A	[1]

INTERDEPENDENCY		
Control Measure	Input / Output	Explanation
WAN-WNAB-CE-PR-04	Input	Pressure relief devices required to ensure system operates within design boundaries
WAN-WNAB-CE-PR-07	Input	Structural integrity required to ensure support for hydrocarbon containing equipment
WAN-WNAB-CE-DC-02	Input	Instrument Protective and Alarm systems required to ensure system operates within design boundaries
WAN-WNAB-CE-DC-03	Input	Shutdown valves required to isolate flammable inventories
WAN-WNAB-CE-DC-04	Output	Hydrocarbon containment of blowdown and vent systems required to ensure MAE does not escalate
WAN-WNAB-CE-MI-02	Input	AFP required to ensure hydrocarbon containment under fire loads

DOCUMENT REFERENCES			
Ref	Document No.	Document Title	Section/Chapter/Page
[1]	WPA-7000-YG-1003	Wandoo Pressure Integrity Manual	
[2]	WNB-3000-RH-0013	WNB Flammable Hazards Analysis	
[3]	WNB-4000-RH-0008	WNA Flammable Hazards Analysis	
[4]	DNV-OS-F101	Submarine Pipeline Systems	
[5]	AS 3788	Pressure equipment - In-service inspection	
[6]	AS 4343	Pressure equipment - Hazard levels	
[7]	API 510	Pressure Vessel Inspection Code	
[8]	API 570	Piping Inspection Code	
[9]	API 579	Fitness for Service	

DOCUMENT CONTROL HISTORY			
Revision	Description	Comments	Date
0	Issued for Use		12 August 2016
1	Issued for Use		20 September 2019
2	Issued for Use	Revised to align with Safety Case Rev 23	November 2020

APPROVALS			
Role	Name	Signature	Date
HSES Manager		ORIGINAL SIGNED	ORIGINAL SIGNED
Asset Integrity Advisor		ORIGINAL SIGNED	ORIGINAL SIGNED
Facility Engineer		ORIGINAL SIGNED	ORIGINAL SIGNED
Field Superintendent		ORIGINAL SIGNED	ORIGINAL SIGNED
Engineering Manager		ORIGINAL SIGNED	ORIGINAL SIGNED

Table 1: WNA Flammable Isolatable Inventories [3]		
Inventory Tag	Description	Isolation Boundary
GA1	Gas Lift Manifold	14-SDV-1078 to 14-UV-0123, 14-UV-0223, 14-UV-0323, 14-UV-0423, 14-UV-0523 and 14-SDV-1131
GA3	Gas Lift line from Gas Lift Manifold to Wellhead	14-WV-0113 to 14-UV-0123, 14-WV-0213 to 14-UV-0223, 14-WV-0313 to 14-UV-0323, 14-WV-0413 to 14-UV-0423, 14-WV-0513 to 14-UV-0523
GL1	Gas Lift Line from WNB	From WNB to 14-SDV-1078

Table 2: WNB Flammable Isolatable Inventories [2]		
Inventory Tag	Description	Isolation Boundary
L02	Oil outlet of Second Stage Separator and rundown to storage	10V1190 to rundown caisson
L06*	Oil outlet of Test Separator to tie-in point with liquid outlets from PS1/2/3	10-SDV-5103 to end of line 150-PF-0071-1D1
L07*	Liquid portion of Test Separator (10V1120)	13-SDV-5101, 10-SDV-5102, 10-SDV-5103, 10-SDV-5104
G01	Gas lift to wells	11-SDV-5375 to 11-RSDV-5426, 37-SDV-5720 and WNB Well AWVs
G02	Gas outlet of Test Separator and Production Separators, Inlet to Gas Lift Compression.	10-SDV-5104, 10-SDV-5114, 10-SDV-5124, 10SDV-5029 to 11-SDV-5361, 11-SDV-5362, 11-SDV-5401, 37-SDV-5731
G03	Gas portion of Production Separator 10V1100	13-SDV-5111, 10-SDV-5112, 10-SDV-5113, 10-SDV-5114
G04	Gas portion of Production Separator 10V1150	13-SDV-5121, 10-SDV-5122, 10-SDV-5123, 10-SDV-5124



TITLE:

HYDROCARBON CONTAINMENT (STATIC EQUIPMENT)

DOC ID:

WAN-WNAB-CE-PR-01

RESPONSIBLE:

FACILITY ENGINEER

Table 2: WNB Flammable Isolatable Inventories [2]

Inventory Tag	Description	Isolation Boundary
G05	Gas portion of Test Separator 10V1120	13-SDV-5101, 10-SDV-5102, 10-SDV-5103, 10-SDV-5104
G06a	Gas Portion of 1st Stage Suction Scrubber (11V4010) and inlet to 1st Stage Compressor (11K4020)	11-SDV-5361, 11-SDV-5362 to 11-PCV-1361, 11-UCV-9362
G06b	Outlet of 1st Stage Compressor (11K4020), 1st Stage Aftercooler (11E4030), Gas Portion of 2nd Stage Suction Scrubber (11V4040) and inlet to 2nd Stage Compressor (11K4050)	11-UCV-9362 to 11-UCV-9372
G06c	Outlet of 2nd Stage Compressor (11K4050), 2 nd Stage Aftercooler (11E4060), Gas Portion of Discharge Scrubber (11V4070) and Compressor Recycle	11-UCV-9372, 11-PCV-136 to 11-SDV-5375
G09a	Recovered Gas Compression	11-SDV-5400 to inlet of Reciprocating Compressors (CYL-2001 and CYL-2002)
G09b	Recovered Gas Compression	Reciprocating Compressors CYL-2001 and CYL-2002 to 11-SDV-5401
G10	Fuel Gas Filter/Distribution	CSC valve on Fuel Gas Treatment Skid, 37-SDV-5724 to 37-SDV-5380, 37-SDV-5860, 37-SDV-5870
G11	Gas Portion of Fuel Gas Scrubber	37V6010 to 37-SDV-5720, 37-SDV-5731
G13	Gas portion of Second Stage Separator (10V1190), Inlet to Recovered Gas Compression	10V1190 to 11-SDV-5400
G14	Gas portion of Production Separator 10V1300	13-SDV-5034, 12-SDV-5335, 10-SDV-5019, 10-SDV-5024, 10-SDV-5029
GL1	Gas Lift Line to WNA	11-RSDV-5426 to WNA
T01*	Test Separator Pump Recycle	13-SDV-5101 to 10V1120
T03*	Test Manifold	From new producing well UMV to 13-SDV-5101
N/A	HP Flare System Pipework & Vessel	All pressure equipment downstream of PSVs and BDVs through to Flare Tip
N/A	LP Vent System Pipework	All pipework downstream of vent ports/nozzles through to LP vent tips
N/A	Closed Drains System Pipework & vessel	All pressure equipment downstream of drain points through to 2 nd Stage Separator inlet

*These inventories are only flammable when flowing a high oil cut (>20% oil) into the Test Separator without commingling with a low oil cut well. This scenario can only occur for up to 6 months following a drilling campaign.



TITLE: HYDROCARBON CONTAINMENT (WELLS) **DOC ID:** WAN-WNAB-CE-PR-02 **RESPONSIBLE:** FACILITY ENGINEER

SAFETY GOAL:	Prevention
OBJECTIVE:	To prevent loss of containment of hydrocarbons from wells, sufficient to result in MAE
MAEs & CEEs:	MAE-01 and CEE-01
SCOPE:	Inclusions: <ul style="list-style-type: none"> Wellheads, Xmas trees and annulus defined as an envelope for containing reservoir hydrocarbons, including all containing components and valves, as per well barrier element drawings, above the Production Packer. Wellheads and annulus defined as an envelope for containing gas-lift hydrocarbons, including all containing components and valves, as per well barrier element drawings. All piping between wellheads and shutdown valves that isolate topside hydrocarbon inventory equipment, namely primary wing valve (PWV) on WNB wells, upper master valve (UMV) on WNA wells, and Gas Lift SDV on all wells.
	Exclusions: <ul style="list-style-type: none"> Wellhead and Xmas tree equipment, including all containing components and valves, as well as annulus not defined as an envelope for containing reservoir or gas lift hydrocarbons as per well barrier element drawings. Production pipework downstream of the specification break between well construction and production facilities (API To B31.3) is covered under WAN-WNAB-CE-PR-01 Gas Lift pipework upstream of the shutdown valve is covered under WAN-WNAB-CE-PR-01 Excludes other process shutdown systems which are covered under WAN-WNAB-CE-DC-03 Shutdown logic covered separately under ICS WAN-WNAB-CE-DC-07 Instrumented protective functions and alarms covered separately under WAN-WNAB-CE-DC-02 Wells undergoing Well Construction / Well Intervention are excluded from scope for the duration of the construction/intervention campaign.

FUNCTIONALITY						
Key Component	Key Requirement	Performance Criteria	Assurance Activity	Minimum Frequency	Assurance Task	Reference
WAN-WNAB-CE-PR-02-01 Wellhead/Trees, Valves, Instrumentation & Casings defined in the containment envelope (barrier)	Wellhead and trees shall contain pressurised hydrocarbons	• There shall be no hydrocarbon leaks/weepers from the wellhead/tree, valves and instrument connections	• Ongoing Ops / Maintenance presence on platform	N/A	N/A	[6][8][12]
		• Critical valves shall sufficiently seal to contain hydrocarbon	• Function Test – Valve Leak off Test	12M	B-131.21 M/PM-12 WNB01-12 B-131.22 M/PM-12 WNB13-14 B-131.23 M/PM-12 WNB10 A-141.21 M/PM-12 WNA03-09	[1][8]
		• All wellhead/tree valves shall be operable	• Function Test – Valve Turns	12M		[1]
		• There shall be no leaks across the internal barrier seals of the wellhead/tree, with leak acceptance criteria of 140µL/min for cavity voids and 1µL/min for inter-seal voids at test pressure.	• Function Test – Void Leak off Test	12M		[1][6]
WAN-WNAB-CE-PR-02-02 Wellhead Actuated Valves (WAVs)	The WAVs close on demand and contain pressurised hydrocarbons	• The WAVs shall close on receiving signal from ICS	• Function Test – Valve Function	12M	B-131.31 CFT/PM-12 WNB01-12 B-131.32 CFT/PM-12 WNB13-14 B-131.33 CFT/PM-12 WNB10 A-141.31 CFT/PM-12 WNA03-09	[11]
		• The WAVs shall fully close within 30 seconds (full closure time is defined as the time from initiation through to valve fully closed)	• Function Test – Valve Function timed	12M		[6][8][11]
		• The WAVs shall sufficiently seal to contain hydrocarbon	• Function Test – Leak off Test	12M		[1][6][8]
WAN-WNAB-CE-PR-02-03 Sub-Surface Safety Valves (SSSVs)	SSSVs isolate well fluids	• SSSVs shall close on receiving signal from ICS.	• Function Test – Valve Function	12M	B-131.31 CFT/PM-12 WNB01-12 B-131.32 CFT/PM-12 WNB13-14 B-131.33 CFT/PM-12 WNB10 A-141.31 CFT/PM-12 WNA03-09	[7][11]
		• SSSVs shall close on manual activation at well control panel.	• Function Test – Valve Function	12M		[7][11]
		• SSSVs shall sufficiently seal to contain hydrocarbon	• Function Test – Leak off Test	12M		[1][7]
WAN-WNAB-CE-PR-02-04 Gas Lift Valve (GLV)	GLV isolates well fluids	• The down-hole GLV shall sufficiently seal to contain backflow of reservoir hydrocarbon	• Function Test – Leak off Test	12M	B-131.31 CFT/PM-12 WNB01-12 B-131.32 CFT/PM-12 WNB13-14 A-141.31 CFT/PM-12 WNA03-09	[1][6][8]
WAN-WNAB-CE-PR-02-05 Annulus	Production and Surface Annuli shall contain pressurised hydrocarbons should a primary barrier fail.	• The measured Annulus Surface Pressure shall be less than 45 Bar.	• Monitoring – Production and surface casing pressures	2W	Weekly Laboratory Tasks	[1][9]

AVAILABILITY / RELIABILITY						
Key Component	Key Requirement	Performance Criteria	Assurance Activity	Minimum Frequency	Assurance Task	Reference
WAN-WNAB-CE-PR-02 All Systems	System availability	• Functional criteria to be available 100% of the time when system is in service	•			[1][12]
WAN-WNAB-CE-PR-02-01 Wellhead/Trees, Valves, Instrumentation & Casings	System availability	• An external hydrocarbon leak is defined as: o Gas: 20% LEL measured at 100mm from source o Liquid: 4 drips per minute, or 1 litre in 24 hrs	•			[1][12]
WAN-WNAB-CE-PR-02-02 WAVs WAN-WNAB-CE-PR-02-03 SSSVs WAN-WNAB-CE-PR-02-04 GLV	System availability	• Acceptable valve seal pass rate when closed is defined as: o Gas: 0.42 Sm ³ /min o Liquid: 400mL/min	•			[1][6][8]
WAN-WNAB-CE-PR-02-01 to 04 Reservoir Containment	Hydrocarbon from Reservoir containment availability (unlimited release potential)	• There shall be a minimum of two confirmed well barrier elements (WBEs) which contain hydrocarbon from the reservoir	•			[1][2][3]
WAN-WNAB-CE-PR-02-05 Gas Lift Containment	Gas Lift containment availability (limited release potential)	• There shall be a minimum of one confirmed well barrier element (WBE) which contains gas lift	•			[1][2][3]
WAN-WNAB-CE-PR-02 All Systems	System reliability	• No specific reliability requirements identified	•			[1][12]



TITLE:

HYDROCARBON CONTAINMENT (WELLS)

DOC ID:

WAN-WNAB-CE-PR-02

RESPONSIBLE:

FACILITY ENGINEER

SURVIVABILITY

Key Component	Key Requirement	Performance Criteria	Assurance Activity	Minimum Frequency	Assurance Task	Reference
WAN-WNAB-CE-PR-06 All Systems	Wellhead valves and associated systems designed to survive all credible fire events	<ul style="list-style-type: none"> Wellhead valves and associated systems designed to be fail safe 	<ul style="list-style-type: none"> Function Test - Valves 	12M	B-131.21 M/PM-12 WNB01-12 B-131.22 M/PM-12 WNB13-14 B-131.23 M/PM-12 WNB10 A-141.21 M/PM-12 WNA03-09	[4][5]

INTERDEPENDENCY

Control Measure	Input / Output	Explanation
WAN-WNAB-CE-PR-07	Input	Structural integrity required to support well systems
WAN-WNAB-CE-DC-02	Input	Instrument Protective and Alarm Systems required to ensure wells kept within operating envelopes
WAN-WNAB-CE-DC-05	Input	Ignition prevention required to identify appropriate EX rating for well systems
WAN-WNAB-CE-MI-02	Input	AFP required to mitigate against fire events leading to escalation

DOCUMENT REFERENCES

Ref	Document No.	Document Title	Section/Chapter/Page
[1]	WPA-7000-YG-1009	Well Integrity Manual (WIMS)	
[2]	VOG-5000-MN-0001	Well Construction Management System Manual	
[3]	VOG-5000-MN-0004	Well Operations Management Plan	
[4]	WNB-3000-RH-0019	WNB Emergency Systems Survivability Analysis (ESSA)	
[5]	WNB-4000-RH-0007	WNA Emergency Systems Survivability Analysis (ESSA)	
[6]	API Specification 6A	Specification for Wellhead and Christmas Tree	
[7]	API Standard 14B	Design, Installation, Repair and Operation of Subsurface Safety Valve Systems	
[8]	API Standard 6AV2	Installation, Maintenance, and Repair of Surface Safety Valves and Underwater Safety Valves Offshore	
[9]	API RP 90	Annular Casing Pressure Management for Offshore Wells	
[10]	AS / IEC 61511	Functional Safety – Safety instrumented systems for the process industry sector	
[11]	ISO 16530-2	ISO 16530-2 Technical Specification. Well Integrity – Part 2: Well Integrity for the Operational Phase	
[12]	OPGGS (RMAR) 2011	Offshore Petroleum Greenhouse Gas Storage (RMA) Regulations 2011	5.02

DOCUMENT CONTROL HISTORY

Revision	Description	Comments	Date
0	Issued for Use		12 August 2016

APPROVALS

Role	Name	Signature	Date
HSES Advisor		ORIGINAL SIGNED	ORIGINAL SIGNED
Asset Integrity Advisor		ORIGINAL SIGNED	ORIGINAL SIGNED
Facility Engineer		ORIGINAL SIGNED	ORIGINAL SIGNED
Field Superintendent		ORIGINAL SIGNED	ORIGINAL SIGNED
Operations Manager		ORIGINAL SIGNED	ORIGINAL SIGNED



TITLE:	LIFTING EQUIPMENT	DOC ID:	WAN-WNAB-CE-PR-05	RESPONSIBLE:	FACILITY ENGINEER
---------------	-------------------	----------------	-------------------	---------------------	-------------------

SAFETY GOAL:	Prevention
OBJECTIVE:	To prevent uncontrolled swinging or dropped loads that could result in an MAE
MAEs & CEEs:	MAE-04, CEE-01
SCOPE:	Inclusions:
	<ul style="list-style-type: none"> Platform Cranes and Man-riding winch, including hoist ropes, boom, sheaves, brakes, winches, gear box, safe load / radius indicator [4] Rigging, including all devices used to support a suspended load, such as wire rope, shackles, soft slings, man-riding basket [3] associated with man-riding and/or crane lifts
SCOPE:	Exclusions:
	<ul style="list-style-type: none"> TEMPSC & WRC davits covered separately under WAN-WNAB-CE-ES-04 - Escape, TR and Evacuation and WAN-WNAB-CE-ES-05 - Rescue and Recovery Facilities respectively. All other mechanical handling devices are excluded as worst credible consequence is single fatality and therefore not an MAE.

FUNCTIONALITY

Key Component	Key Requirement	Performance Criteria	Assurance Activity	Minimum Frequency	Assurance Task	Reference
WAN-WNAB-CE-PR-05-01 Platform Cranes and Man-riding Winch	Safely performs lifting operations to prevent dropped objects or swinging loads	• Structural components shall be free from wear, cracks, distortion, chipping or other mechanical damage.	• Visual Inspection	12M	A0000534; B-401.00 M/PM-12 A0001155; B-401.05 M/IN-12	[1][2][4][5]
		• Brake systems shall operate on demand.	• Function Test	12M	A0000533; B-401.00 M/PM-03 A0000538; B-401.03 M/IN-12	[1][2][3][4][5]
		• Gearbox shall be fit for service with fluid integrity	• Visual Inspection	12M	A0000533; B-401.00 M/PM-03 A0000538; B-401.03 M/IN-12	[1][2][4][5]
		• The safe load / radius indicator shall function correctly and be accurate	• Function Test	12M	A0000533; B-401.00 M/PM-03	[1][2][4][5]
		• The crane limit switches are set and operate correctly	• Function Test	12M	A0000533; B-401.00 M/PM-03	[1][2][4][5]
		• Winches are fit for service	• Visual Inspection	12M	A0000533; B-401.00 M/PM-03 A0000538; B-401.03 M/IN-12	[1][2][4][5]
		• Wire Ropes, Sheaves and hooks are fit for service	• Visual Inspection	12M	A0000533; B-401.00 M/PM-03 A0000538; B-401.03 M/IN-12	[1][2][4][5]
WAN-WNAB-CE-PR-05-02 Rigging associated with man-riding and/or crane lifts	Safely supports a load	• All rigging shall be in good physical condition and within certification.	• Visual Inspection & Certification	12M	A0000940; B-401.01 M/IN-12	[1][2][4][6]

AVAILABILITY / RELIABILITY

Key Component	Key Requirement	Performance Criteria	Assurance Activity	Minimum Frequency	Assurance Task	Reference
WAN-WNB-CE-PR-01 All Systems	• System availability	• Functional criteria to be available 100% of the time when system is in service	• N/A			[7][8]
WAN-WNB-CE-PR-01 All Systems	• System reliability	• No specific reliability criteria defined	• N/A			[7][8]

SURVIVABILITY

Key Component	Key Requirement	Performance Criteria	Assurance Activity	Minimum Frequency	Assurance Task	Reference
WAN-WNB-CE-PR-01 All Systems	• No specific survivability requirement.	• N/A	• N/A	N/A	N/A	[7][8]

INTERDEPENDENCY

Control Measure	Input / Output	Explanation
WAN-WNAB-CE-PR-07	Input	Structural integrity required to ensure support for lifting equipment

DOCUMENT REFERENCES

Ref	Document No.	Document Title	Section/Chapter/Page
[1]	WPA-7000-YG-1005	Structural Integrity Manual	
[2]	WPA-7000-YM-0002.01	Lifting Management Manual	
[3]	WPA-7000-YM-0002.02	Lifting Equipment Manual	
[4]	WPA-7000-YM-0002.03	Crane Operation, Maintenance & Inspection Manual	
[5]	API RP 2D	Operation and Maintenance of Offshore Cranes	
[6]	AS/NZS 1418	Cranes, Hoists and Winches	
[7]	WNB-3000-RH-0019	WNB Emergency Systems Survivability Analysis (ESSA)	
[8]	WNB-4000-RH-0007	WNA Emergency Systems Survivability Analysis (ESSA)	



TITLE:

LIFTING EQUIPMENT

DOC ID:

WAN-WNAB-CE-PR-05

RESPONSIBLE:

FACILITY ENGINEER

DOCUMENT CONTROL HISTORY

Revision	Description	Comments	Date
0	Issued for Use		12 August 2016

APPROVALS

Role	Name	Signature	Date
HSES Advisor		ORIGINAL SIGNED	ORIGINAL SIGNED
Asset Integrity Advisor		ORIGINAL SIGNED	ORIGINAL SIGNED
Facility Engineer		ORIGINAL SIGNED	ORIGINAL SIGNED
Field Superintendent		ORIGINAL SIGNED	ORIGINAL SIGNED
Operations Manager		ORIGINAL SIGNED	ORIGINAL SIGNED



TITLE: NAVIGATION AIDS **DOC ID:** WAN-WNAB-CE-PR-06 **RESPONSIBLE:** FACILITY ENGINEER

SAFETY GOAL:	Prevention
OBJECTIVE:	To alert marine vessels and aircraft of the position of the installation so that they may take timely action to avoid the area
MAEs & CEEs:	MAE-5.1, MAE-06, CEE-01 and CEE-03
SCOPE:	Inclusions: <ul style="list-style-type: none"> • Scope includes all the provisions required to enable the facility, its structures and appurtenances to be recognised by marine or aviation traffic and to ensure a safe line of approach or departure for helicopters, to prevent collision with the facilities, including: <ul style="list-style-type: none"> ○ Navigation lights ○ Foghorns ○ Aircraft obstruction lights (including Wandoo A platform, Wandoo B crane and Wandoo B flare boom lights)
	Exclusions: <ul style="list-style-type: none"> • Excludes emergency lighting which is covered under WAN-WNAB-CE-ES-03 • Excludes emergency communications which are covered under WAN-WNAB-CE-02 • WNB general Helideck lighting covered under WAN-WNAB-CE-PR-08 – Helideck

FUNCTIONALITY

Key Component	Key Requirement	Performance Criteria	Assurance Activity	Minimum Frequency	Assurance Task	Reference
WAN-WNAB-CE-PR-06.01 Navigation Lights	To provide visual indication to marine vessels of the position of the installation (WNA & WNB) so that they may take timely action to avoid the area	• Lenses are aligned and clean & free from damage, debris & obstruction	• Inspection	12M	A0000857; A-140.11 E/PM-06 A0000702; B-762.00 E/PM-12	[4]
		• The lights are activated between sunset and sunrise	• Function Test	1W	Daily Nightshift Check sheet	[4]
		• The lights flash a letter 'U' in Morse code every 15 seconds and globes are rated to an effective intensity of 1400 candelas	• Function Test	12M	A0000857; A-140.11 E/PM-06 A0000702; B-762.00 E/PM-12	[4]
		• The flashing of multiple lights on a single facility are synchronised	• Function Test	12M	A0000857; A-140.11 E/PM-06 A0000702; B-762.00 E/PM-12	[4]
	To provide visual indication to marine vessels of the presence of the CALM buoy so that they may take timely action to avoid the area	• CALM Buoy single navigation light lens is aligned, clean & free from damage, debris & obstruction	• Inspection	12M	A0001261; P-161.00 P/PM-12W	[4]
		• The lights are activated between sunset and sunrise.	• Inspection	1W	Daily Nightshift Check sheet	[4]
WAN-WNAB-CE-PR-06.02 Fog Horn	To provide audible indication to marine vessels of the position of the each fixed installation (WNA and WNB) so that they may take timely action to avoid the area	• Horn sounds when manually initiated	• Function Test	12M	A0000702; B-762.00 E/PM-12 A0000857; A-140.11 E/PM-06	[5]
		• The fog horn sounds in a letter 'U' in Morse code every 30 seconds.	• Function Test	12M	A0000702; B-762.00 E/PM-12 A0000857; A-140.11 E/PM-06	[4][5]
		• The foghorn sound has a minimum range of 2 Nautical miles	• Function Test	12M	A0000702; B-762.00 E/PM-12 A0000857; A-140.11 E/PM-06	[5]
		• Fog horn is free from damage, debris and obstructions	• Inspection	12M	A0000702; B-762.00 E/PM-12 A0000857; A-140.11 E/PM-06	[4][5]
WAN-WNAB-CE-PR-06.03-01 WNB Aircraft Obstruction Lights	To provide visual indication to aircraft of the presence of the WNB platform crane and flare boom so that they may take timely action to avoid the area	• Obstruction lights located on the WNB crane and flare boom are functional	• Inspection & Maintenance	12M	A0000700; B-761.00 E/PM-12	[6]
WAN-WNAB-CE-PR-06.03-02 WNA Aircraft Obstruction Light	To provide visual indication to aircraft of the presence of the WNA platform so that they may take timely action to avoid structure	• Obstruction light located on the WNA helideck access stair tower is functional	• Inspection & Maintenance	12M	A0000857; A-140.11 E/PM-06	[6]
WAN-WNAB-CE-PR-06.04 Navigation Power Supply	To provide an uninterrupted power supply for critical systems following an AC Power Failure.	• The DC unit battery must be capable of supplying power to the DC Unit essential service users for a minimum duration of 96 hours	• Function Test	12M	A0000702; B-762.00 E/PM-12	[4]

AVAILABILITY / RELIABILITY

Key Component	Key Requirement	Performance Criteria	Assurance Activity	Minimum Frequency	Assurance Task	Reference
WAN-WNAB-CE-PR-06 All Systems	System availability	• Functional criteria to be available 100% of the time when system is in service	• By Design			[1][2]
WAN-WNAB-CE-PR-06.01 Navigation Lights	System availability	• Platforms are fitted with navigational lights at opposite corners of the platform. • Functional criteria to be available 100% of the time during hours of darkness (sunset to sunrise)	• By Design			[1][2]
WAN-WNAB-CE-PR-06.02 Fog Horn	System availability	• Functional criteria to be available 100% of the time during periods of low visibility due to fog	• By Design			[1][2]
WAN-WNAB-CE-PR-06.03 Obstruction Lights	System availability	• Functional criteria to be available 100% of the time during helicopter operations and during hours of darkness only.	• By Design			[1][2]
WAN-WNAB-CE-PR-06.04 Navigation Power Supply	System availability	• Functional criteria to be available 100% of the time when systems are in service	• By Design			[1][2]
WAN-WNAB-CE-PR-06 All Systems	System reliability	• No specific reliability criteria defined	• N/A			[1][2]



TITLE:

NAVIGATION AIDS

DOC ID:

WAN-WNAB-CE-PR-06

RESPONSIBLE:

FACILITY ENGINEER

SURVIVABILITY

Key Component	Key Requirement	Performance Criteria	Assurance Activity	Minimum Frequency	Assurance Task	Reference
WAN-WNAB-CE-PR-06 All Systems	No specific survivability criteria	• N/A	•			[1][2]

INTERDEPENDENCY

Control Measure	Input / Output	Explanation
WAN-WNAB-CE-PR-07	Input	Structural integrity required to support Navigation Aids
WAN-WNAB-CE-PR-08	Output	Navigation Aids required to prevent potential helicopter crash
WAN-WNAB-CE-DC-05	Input	Ignition prevention required to identify appropriate EX rating for Navigation Aids
WAN-WNAB-CE-ES-01	Input	UPS required for provision of power to essential Navigation Aids

DOCUMENT REFERENCES

Ref	Document No.	Document Title	Section/Chapter/Page
[1]	WNB-3000-RH-0015	WNB Non-Flammable Hazards Analysis	
[2]	WNB-4000-RH-0004	WNA Non-Flammable Hazards Analysis	
[3]	WPA-7000-YG-1008	Communication & Navigation Integrity Manual	
[4]	IALA Recommendation O-139	International Association of Marine Aids to Navigation and Lighthouse Authorities Recommendation O-139 on The marking of man-made offshore structures	
[5]	IALA Guideline No 1090	International Association of Marine Aids to Navigation and Lighthouse Authorities Guideline No. 1090 On the use of Audible Signals	
[6]	CAAP 92-4(0)	Guidelines for the development and operation of off-shore helicopter landing sites	

DOCUMENT CONTROL HISTORY

Revision	Description	Comments	Date
0	Issued for Use		12 August 2016
1	Issued for Use	Updated to align with Safety Case Rev 23	November 2020

APPROVALS

Role	Name	Signature	Date
HSES Manager		ORIGINAL SIGNED	ORIGINAL SIGNED
Asset Integrity Manager		ORIGINAL SIGNED	ORIGINAL SIGNED
Facility Engineer		ORIGINAL SIGNED	ORIGINAL SIGNED
Field Superintendent		ORIGINAL SIGNED	ORIGINAL SIGNED
Engineering Manager		ORIGINAL SIGNED	ORIGINAL SIGNED



TITLE:	STRUCTURAL INTEGRITY	DOC ID:	WAN-WNAB-CE-PR-07	RESPONSIBLE:	FACILITY ENGINEER
---------------	----------------------	----------------	-------------------	---------------------	-------------------

SAFETY GOAL:	Prevention
OBJECTIVE:	To provide structural support to critical control measures.
MAEs & CEEs:	MAE-04, MAE-06, MAE-07, CEE-01 and CEE-03
SCOPE:	<p>Inclusions:</p> <ul style="list-style-type: none"> • All Superstructure (Topsides) that provide support to critical control measures (including plant, equipment, primary escape access & egress and buildings), including: <ul style="list-style-type: none"> ○ Crane pedestal ○ Flare Boom ○ Helideck ○ Accommodation Modules ○ TR Module ○ Primary Escape Access and Egress • All Substructure (CGS) that provide support to critical control measures (including plant, equipment, and topside structure), including: <ul style="list-style-type: none"> ○ Supporting appurtenances (e.g. fire water caissons, riser clamps) ○ Scour control measures ○ Corrosion control measures ○ Collision protection structures (e.g. conductor protection frame) • Mooring system for non DP systems, including <ul style="list-style-type: none"> ○ CALM Buoy, including mooring arm ○ Chains and Anchors ○ Hawser, and appurtenances <p>Exclusions:</p> <ul style="list-style-type: none"> • Fire/blast rated walls covered under WAN-WNAB-CE-MI-01 - Fire and Explosion Protection • Pipe/equipment supports for hydrocarbon containing equipment covered under WAN-WNAB-CE-PR-01 - Hydrocarbon Containment (Static Equipment) and WAN-WNAB-CE-PR-03 - Rotating Equipment • Decks and bunds are covered under WAN-WNAB-CE-DC-06 - Drainage and Bunding • Vessel Davit Arms are covered under WAN-WNAB-CE-ES-04 for TEMPSC and WAN-WNAB-CE-ES-05 for the WRC • Secondary and tertiary supporting steel work is not considered safety critical

FUNCTIONALITY						
Key Component	Key Requirement	Performance Criteria	Assurance Activity	Minimum Frequency	Assurance Task	Reference
WAN-WNAB-CE-PR-07-01 All Structures	To provide support to critical control measures	• Operated within acceptable load & distribution limits.	• Weight Management Audit Report	12M	B-19.301 S/CM 12 –PS-034	[3][4][5][6][7][8]
		• Physical condition and anomalous effects shall remain within acceptable limits.	• Visual Inspection (PS-035) • Non-Intrusive Inspection	60M	A0000825; B-998.11 M/IN-60 A0000826; B-998.12 M/IN-60 A0000827; B-998.13 M/IN-60 A0001380; B-191.00-M/IN-12	[3][4][5][6][7][8]
WAN-WNAB-CE-PR-07-02 Mooring System	To prevent tanker loss of station keeping	• Physical condition and anomalous effects shall remain within acceptable limits.	• Visual Inspection • Non-Intrusive Inspection	60M	PS-049	[3][9]

AVAILABILITY / RELIABILITY						
Key Component	Key Requirement	Performance Criteria	Assurance Activity	Minimum Frequency	Assurance Task	Reference
WAN-WNAB-CE-PR-07 All Systems	System availability	• Functional criteria to be available 100% of the time when system is in service	• N/A	N/A	N/A	[1][2]
WAN-WNAB-CE-PR-07 All Systems	System reliability	• No specific reliability criteria defined	• N/A	N/A	N/A	[1][2]

SURVIVABILITY						
Key Component	Key Requirement	Performance Criteria	Assurance Activity	Minimum Frequency	Assurance Task	Reference
WAN-WNAB-CE-PR-07 All systems	No specific survivability requirements identified for fire cases – covered by WAN-WNB-CE-MI-01 - Fire and Explosion Protection	• N/A	• N/A	N/A	N/A	[1][2]
WAN-WNAB-CE-PR-07 All systems	Structures to survive credible ship impacts	• WNB substructure designed to withstand impact energy of 4.5MJ • WNA monopod designed to withstand impact energy of 800kJ	• Design	N/A	N/A	[1][2]
WAN-WNAB-CE-PR-07 All systems	Structures to survive credible seismic events	• Substructures/foundations reliability 1E-4 per annum for manned facilities.	• Design	N/A	N/A	[1][2]
WAN-WNAB-CE-PR-07 All systems	Structures to survive credible extreme weather events	• Substructures/foundations reliability 5E-4 per annum for evacuated facilities.	• Design	N/A	N/A	[1][2]

INTERDEPENDENCY			
Control Measure	Input / Output	Explanation	
WAN-WNAB-CE-PR-01	Output	Structural integrity required to support hydrocarbon containing equipment	



TITLE: STRUCTURAL INTEGRITY **DOC ID:** WAN-WNAB-CE-PR-07 **RESPONSIBLE:** FACILITY ENGINEER

INTERDEPENDENCY		
Control Measure	Input / Output	Explanation
WAN-WNAB-CE-PR-02	Output	Structural integrity required to support hydrocarbon containing equipment
WAN-WNAB-CE-PR-03	Output	Structural integrity required to support rotating equipment
WAN-WNAB-CE-PR-05	Output	Structural integrity required to support lifting equipment
WAN-WNAB-CE-PR-06	Output	Structural integrity required to support NAVAIDs
WAN-WNAB-CE-DC-06	Input	Drainage and bunding required to remove hazardous releases to safe location and away from critical structures
WAN-WNAB-CE-MI-01	Input	Fire and blast protection required to ensure survivability of critical structures.
WAN-WNAB-CE-ES-04	Output	Structural integrity required to support escape, TR and evacuation systems
WAN-WNAB-CE-ES-05	Output	Structural integrity required to support rescue and recovery systems

DOCUMENT REFERENCES			
Ref	Document No.	Document Title	Section/Chapter/Page
[1]	WNB-3000-RH-0015	WNB Non-Flammable Hazards Analysis	
[2]	WNB-4000-RH-0004	WNA Non-Flammable Hazards Analysis	
[3]	WPA-7000-YG-1005	Structural Integrity Manual	
[4]	ISO 19900	Petroleum and natural gas industries -- General requirements for offshore structures	
[5]	ISO 19901	Petroleum and natural gas industries -- Specific requirements for offshore structures	Parts 1 to 5
[6]	ISO 19902	Petroleum and natural gas industries -- Fixed steel offshore structures	
[7]	ISO 19903	Petroleum and natural gas industries -- Fixed concrete offshore structures	
[8]	NORSOK N006	Assessment of structural integrity for existing offshore load-bearing structures	
[9]	WPA-7000-YV-0002	SPM Marine Facilities Procedures	

DOCUMENT CONTROL HISTORY			
Revision	Description	Comments	Date
0	Issued for Use		12 August 2016

APPROVALS			
Role	Name	Signature	Date
HSES Advisor		ORIGINAL SIGNED	ORIGINAL SIGNED
Asset Integrity Advisor		ORIGINAL SIGNED	ORIGINAL SIGNED
Facility Engineer		ORIGINAL SIGNED	ORIGINAL SIGNED
Field Superintendent		ORIGINAL SIGNED	ORIGINAL SIGNED
Operations Manager		ORIGINAL SIGNED	ORIGINAL SIGNED



TITLE: PROTECTIVE INSTRUMENTATION SYSTEMS **DOC ID:** WAN-WNAB-CE-DC-02 **RESPONSIBLE:** FACILITY ENGINEER

SAFETY GOAL:	Control
OBJECTIVE:	To prevent loss of containment of a flammable or hazardous substance due to operation outside design limits
MAEs & CEEs:	MAE-01, MAE-02, MAE-03, CEE-01
SCOPE:	Inclusions: <ul style="list-style-type: none"> • Instrumentation initiators and alarms that ensure the process remains within its designed operational envelope by initiating shutdown of either flammable inventories [3][4] or equipment with a Hazard Level of B or higher as defined by AS 4343, including: <ul style="list-style-type: none"> ○ xZT instrumentation associated with flammable or hazardous inventories [3][4] ○ cabling from safety critical xZT transmitters to the Control Panels <ul style="list-style-type: none"> ▪ See Tables 2, 3 & 4 below for listing of all safety critical xZT instrumentation.
	Exclusions: <ul style="list-style-type: none"> • Those systems associated with the Fire & Gas detection system are covered under WAN-WNAB-CE-DC-01 Fire & Gas Detection • Those systems associated with shutdown system functionality (including outputs from the Process Control Panel) are covered under WAN-WNAB-CE-DC-03 Shutdown Systems • All control and shutdown logic provided by WAN-WNAB-CE-DC-07 Integrated Control System • All other process alarms associated with pressure, level, temperature, flow, etc transmitters (not associated with xZT transmitters) do not provide a safety critical function and are therefore excluded from scope. • All xZT transmitters that solely initiate shutdown of non-flammable inventories or equipment with a Hazard Level of C or lower as defined by AS 4343 do not provide a safety critical function and are therefore excluded from scope.

FUNCTIONALITY

Key Component	Key Requirement	Performance Criteria	Assurance Activity	Minimum Frequency	Assurance Task	Reference
WAN-WNAB-CE-DC-02-01 Field Instrument Initiator	To sense process or equipment conditions that require an appropriate executive action	• Automatic field initiators shall operate and alarm in accordance with corresponding trip set points.	• Visual Inspection • Function Test	12M 12M	Refer Table 1 A0001036; B-105.11 I/CFT-12	[1][2]
		• Field Initiators to be in good condition	• Visual Inspection	12M	Refer Table 1 A0001036; B-105.11 I/CFT-12	[1][2]
WAN-WNAB-CE-DC-02-02 Output Signals & Cabling to Control Panel	To ensure signals are transmitted to the platform integrated control system.	• Faults or open circuits shall annunciate in the control room.	• Function Test	12M	Refer Table 1 A0001036; B-105.11 I/CFT-12	[1][2]

AVAILABILITY / RELIABILITY

Key Component	Key Requirement	Performance Criteria	Assurance Activity	Minimum Frequency	Assurance Task	Reference
WAN-WNB-CE-DC-02 All Systems	System availability	• Functional criteria to be available 100% of the time when related equipment is in service and contains flammable/hazardous inventory	• N/A			
WAN-WNB-CE-DC-02 All Systems	System reliability	• No specific reliability criteria defined.	• N/A			

SURVIVABILITY

Key Component	Key Requirement	Performance Criteria	Assurance Activity	Minimum Frequency	Assurance Task	Reference
WAN-WNB-CE-DC-02 All Systems	No specific survivability requirement, elements are required to complete their functions prior to any MAE.	• N/A	• N/A			

INTERDEPENDENCY

Control Measure	Input / Output	Explanation
WAN-WNAB-CE-PR-01	Output	Instrument Protective and Alarm Systems required to mitigate hydrocarbon loss of containment
WAN-WNAB-CE-PR-02	Output	Instrument Protective and Alarm Systems required to mitigate hydrocarbon loss of containment
WAN-WNAB-CE-PR-03	Output	Instrument Protective and Alarm Systems required to mitigate hydrocarbon loss of containment
WAN-WNAB-CE-PR-09	Input	Electrical distribution required for provision of power to essential instrument protective and alarm systems
WAN-WNAB-CE-DC-03	Output	Instrument protective and alarm systems required to initiate shutdown
WAN-WNAB-CE-DC-04	Output	Instrument protective and alarm systems required to initiate blowdown
WAN-WNAB-CE-DC-05	Input	Ignition prevention required to identify appropriate EX rating for Instrument protective and alarm elements
WAN-WNAB-CE-DC-07	Output	Instrument protective and alarm systems required to send appropriate signals to the ICS

DOCUMENT REFERENCES

Ref	Document No.	Document Title	Section/Chapter/Page
[1]	AS / IEC 61511 -2004	Functional Safety - Safety instrumented systems for the process industry sector	
[2]	AS 61508-2011	Functional safety of electrical/electronic/programmable electronic safety-related systems	
[3]	WNB-3000-RH-0013	WNB Flammable Hazards Analysis	
[4]	WNB-4000-RH-0008	WNA Flammable Hazards Analysis	
[5]	WPA-7000-YG-1004	Fire & Safety Systems Integrity Manual	
[6]	AS 4343	Pressure Equipment – Hazard Levels	



TITLE: PROTECTIVE INSTRUMENTATION SYSTEMS DOC ID: WAN-WNAB-CE-DC-02 RESPONSIBLE: FACILITY ENGINEER

DOCUMENT CONTROL HISTORY

Revision	Description	Comments	Date
0	Issued for Use		12 August 2016
1	Issued for Use		20 September 2019
2	Issued for Use	Revised to align with Safety Case Rev 23	November 2020

APPROVALS

Role	Name	Signature	Date
HSES Manager		ORIGINAL SIGNED	ORIGINAL SIGNED
Asset Integrity Advisor		ORIGINAL SIGNED	ORIGINAL SIGNED
Facility Engineer		ORIGINAL SIGNED	ORIGINAL SIGNED
Field Superintendent		ORIGINAL SIGNED	ORIGINAL SIGNED
Engineering Manager		ORIGINAL SIGNED	ORIGINAL SIGNED

TABLE 1

Reference	Reference	Reference	Reference
System 10, Process Oil • A0000002; B-101.00 I/PM-12 • A0000009; B-102.00 I/PM-12 • A0000013; B-103.00 I/PM-12 • A0000017; B-104.01 I/PM-12 • A0000031; B-105.00 I/PM-12 • A0000037; B-106.01 I/PM-12 • A0000042; B-106.02 I/PM-12 • A0000046; B-106.05 I/PM-12 • A0000066; B-109.02 I/PM-12 • A0002111; B-109.30 I/PM-12	System 13, Wellheads & Manifolds • A0000131; B-131.01 I/PM-12 • A0000132; B-131.02 I/PM-12 • A0000133; B-131.03 I/PM-12 • A0000134; B-131.04 I/PM-12 • A0000135; B-131.05 I/PM-12 • A0000136; B-131.06 I/PM-12 • A0000137; B-131.07 I/PM-12 • A0000138; B-131.08 I/PM-12 • A0000139; B-131.09 I/PM-12 • A0000140; B-131.10 I/PM-12 • A0000141; B-131.11 I/PM-12 • A0001122; B-131.12 I/PM-12 • A0001211; B-131.14 I/PM-12 • A0001213; B-131.15 I/PM-12 • A0000153; B-134.02 I/PM-12	System 14, Wandoo A • A0000871; A-141.21 I/CFM-12 • A0000872; A-142.00 I/PM-12 • A0000882; A-144.00 I/PM-12 System 20, Flare & Vent • A0000161; B-201.00 I/PM-12 System 27, Closed Drains • A0000324; B-271.00 I/PM-12 System 30, Heating Medium • A0000328; B-301.00 I/PM-12 • A0000338; B-301.01 I/PM-12 • A0000339; B-301.11 I/PM-12 • A0000340; B-301.12 I/PM-12	System 36, Diesel Fuel • A0000453; B-361.00 I/PM-12 System 37, Fuel Gas & Nitrogen • A0000475; B-371.00 I/PM-12 • A0000477; B-371.01 I/PM-12 • A0000478; B-371.02 I/PM-12 • A0000487; B-372.00 I/PM-12 System 38, Instrument Air • A0000324; B-271.00 I/PM-12

Table 2: WNA Safety Critical Instrumentation

Inventory Tag	Description	xZT
GA1	Gas Lift Manifold	All devices
GL1	Gas Lift Line to WNA	All devices

Table 3: WNB Safety Critical Instrumentation

Inventory Tag	Description	xZT	Inventory Tag	Description	xZT
L02	Liquid portion of Second Stage Separator 10V1190	All devices	G09a	Recovered Gas Compression	All devices
L06	Liquid outlets of Production Separators and Test Separator, and inlet/outlet of Crude Heaters (10E1180 A/B)	All devices	G09b	Recovered Gas Compression	All devices
L07	Liquid portion of Test Separator (10V1120)	All devices	G10	Fuel Gas Filter/Distribution	All devices
G01	Gas lift to wells	All devices	G11	Gas Portion of Fuel Gas Scrubber	All devices
G03	Gas portion of Production Separator 10V1100	All devices	G13	Gas portion of Second Stage Separator (10V1190), Inlet to Recovered Gas Compression	All devices
G04	Gas portion of Production Separator 10V1150	All devices	G14	Gas Portion of Production Separator 10V1300	All devices
G05	Gas portion of Test Separator 10V1120	All devices	T01	Test Separator	All devices
G06a	Gas Portion of 1st Stage Suction Scrubber (11V4010) and inlet to 1st Stage Compressor (11K4020)	All devices	T03	Test Manifold (Sand Filters)	All devices
G06b	Outlet of 1st Stage Compressor (11K4020), 1st Stage Aftercooler (11E4030), Gas Portion of 2nd Stage Suction Scrubber (11V4040) and inlet to 2nd Stage Compressor (11K4050)	All devices	GL1	Gas Lift Line to WNA	All devices
G06c	Outlet of 2nd Stage Compressor (11K4050), 2nd Stage Aftercooler (11E4060), Gas Portion of Discharge Scrubber (11V4070) and Compressor Recycle	All devices			

Table 4: WNB Safety Critical Instrumentation (Non-Flammable Inventories)

Inventory Tag	Description	xZT	Inventory Tag	Description	ZT
N/A	Gas Lift Pig Launcher		N/A	Nitrogen Adsorption Vessels	
N/A	Compact Flotation Units (CFUs)		N/A	Instrument Air System	
N/A	36F7690B - Diesel Filter Separator B		N/A	Air Compressor Air Driers	
N/A	Heating Medium Expansion Vessel		N/A	Pedestal Crane Air Receiver	



TITLE: PROTECTIVE INSTRUMENTATION SYSTEMS DOC ID: WAN-WNAB-CE-DC-02 RESPONSIBLE: FACILITY ENGINEER

Table 4: WNB Safety Critical Instrumentation (Non-Flammable Inventories)

Inventory Tag	Description	xZT	Inventory Tag	Description	ZT
N/A	Nitrogen Unit Air Receiver		N/A	Emergency Generator Air Start Receiver	
N/A	Nitrogen Unit Nitrogen Receiver				



TITLE: SHUTDOWN VALVES **DOC ID:** WAN-WNAB-CE-DC-03 **RESPONSIBLE:** FACILITY ENGINEER

SAFETY GOAL:	Control
OBJECTIVE:	To isolate hazardous inventories associated with MAE potential.
MAEs & CEEs:	MAE-01, MAE-02, MAE-03
SCOPE:	Inclusions:
	<ul style="list-style-type: none"> All shutdown valves, including valve actuators and their local control circuits, immediately upstream/downstream of any identified flammable inventory [1][2] or equipment with a Hazard Level of B or higher as defined by AS 4343 with potential for MAE. All safety critical shutdown valves are detailed in Table 1, and all safety critical riser shutdown valves detailed in Table 2.
SCOPE:	Exclusions:
	<ul style="list-style-type: none"> Excludes all shutdown valves associated with isolating inventories with no MAE potential (i.e. valves not listed in the Tables 1 or 2). Note, however, that these excluded valves still have non-critical environmental performance requirements. Excludes process shutdown initiators which are covered under WAN-WNAB-CE-DC-02 - Instrument Protective and Alarm Systems Excludes F&G initiators which are covered under WAN-WNAB-CE-DC-01 - Fire and Gas Detection Systems Excludes initiator alarms and logic solvers which are covered under WAN-WNAB-CE-DC-07 - Integrated Control System Excludes Well-related Shutdown Valves which are covered under WAN-WNAB-CE-PR-02 - Hydrocarbon Containment (Wells)

FUNCTIONALITY

Key Component	Key Requirement	Performance Criteria	Assurance Activity	Minimum Frequency	Assurance Task	Reference
WAN-WNB-CE-DC-03-01 Process Shutdown Valves	To isolate hazardous inventories	<ul style="list-style-type: none"> Process Shutdown valves to actuate on demand. 	<ul style="list-style-type: none"> Function Test 	12M	A0001200; B-102.15 P/PM-12 A0001202; B-102.14 P/PM-03 A0001204; B-102.13 P/PM-03	[5]
		<ul style="list-style-type: none"> Process Shutdown valves shall close within 15 seconds 	<ul style="list-style-type: none"> Function Test 	12M	A0001200; B-102.15 P/PM-12 A0001202; B-102.14 P/PM-03 A0001204; B-102.13 P/PM-03	[1][2]
WAN-WNB-CE-DC-03-2 Riser Shutdown Valves	To isolate hazardous inventories	<ul style="list-style-type: none"> Riser Shutdown valves to actuate on demand. 	<ul style="list-style-type: none"> Function Test 	12M	A0001111; B-130.00 M/CFT-12	[5]
		<ul style="list-style-type: none"> Riser Shutdown valves shall close within 30 seconds 	<ul style="list-style-type: none"> Function Test 	12M	A0001111; B-130.00 M/CFT-12	[1][2]
		<ul style="list-style-type: none"> Riser Shutdown valves shall not pass when closed 	<ul style="list-style-type: none"> Function Test 	12M	A0001111; B-130.00 M/CFT-12	[3][4]

AVAILABILITY / RELIABILITY

Key Component	Key Requirement	Performance Criteria	Assurance Activity	Minimum Frequency	Assurance Task	Reference
WAN-WNB-CE-DC-03 All Shutdown Valves	System availability	<ul style="list-style-type: none"> Functional criteria to be available during ESD-0, ESD-1 and ESD-2 events when system contains flammable/hazardous inventory 	<ul style="list-style-type: none"> N/A 	N/A	N/A	[1][2]
WAN-WNB-CE-DC-03-2 Riser Shutdown Valves	System availability	<ul style="list-style-type: none"> A pass rate when closed is defined as: <ul style="list-style-type: none"> Gas: 0.42 m³/min Liquid: 400mL/min 	<ul style="list-style-type: none"> N/A 	N/A	N/A	[4]
WAN-WNB-CE-DC-03 Shutdown Valves	System reliability	<ul style="list-style-type: none"> No specific reliability criteria defined 	<ul style="list-style-type: none"> N/A 	N/A	N/A	[1][2]

SURVIVABILITY

Key Component	Key Requirement	Performance Criteria	Assurance Activity	Minimum Frequency	Assurance Task	Reference
WAN-WNB-CE-DC-03 Shutdown Valves	Valves to survive credible flammable MAEs for sufficient time to actuate	<ul style="list-style-type: none"> Valves are fire rated 	<ul style="list-style-type: none"> By design 	N/A	N/A	[1][2][6]

INTERDEPENDENCY

Control Measure	Input / Output	Explanation
WAN-WNAB-CE-PR-01	Output	Shutdown systems required to aid in hydrocarbon containment
WAN-WNAB-CE-PR-03	Output	Shutdown systems required to aid in hydrocarbon containment
WAN-WNAB-CE-DC-01	Input	F&G imitators required to signal ESD
WAN-WNAB-CE-DC-02	Input	Instrumented protective and alarm systems required to signal ESD
WAN-WNAB-CE-DC-05	Input	Ignition prevention required to confirm hazardous area rated equipment
WAN-WNAB-CE-DC-07	Input	Integrated control system required to signal ESD

DOCUMENT REFERENCES

Ref	Document No.	Document Title	Section/Chapter/Page
[1]	WNB-3000-RH-0013	WNB Flammable Hazards Analysis	
[2]	WNB-4000-RH-0008	WNA Flammable Hazards Analysis	
[3]	VOG-1100-YQ-2007	Fire & Safety Systems Integrity Manual	
[4]	API 6AV2:2014	Recommended Practice for Installation, Maintenance and Repair of Surface Safety Valves and Underwater Safety Valves Offshore - First Edition; ERTA 1: August 2014	
[5]	API 14C:2001	Recommended Practice for Analysis, Design, Installation, and Testing of Basic Surface Safety Systems for Offshore Production Platforms - Seventh Edition (R2007)	
[6]	WNB-7000-SX-0002	Specifications – Piping and Valve Materials	Attachment 5
[7]	AS 4343	Pressure Equipment – Hazard Levels	



TITLE: SHUTDOWN VALVES DOC ID: WAN-WNAB-CE-DC-03 RESPONSIBLE: FACILITY ENGINEER

DOCUMENT CONTROL HISTORY

Revision	Description	Comments	Date
0	Issued for Use		12 August 2016
1	Issued for Use		20 September 2019
2	Issued for use	Revised to align with Safety Case Rev 23	November 2020

APPROVALS

Role	Name	Signature	Date
HSES Manager		ORIGINAL SIGNED	ORIGINAL SIGNED
Asset Integrity Advisor		ORIGINAL SIGNED	ORIGINAL SIGNED
Facility Engineer		ORIGINAL SIGNED	ORIGINAL SIGNED
Field Superintendent		ORIGINAL SIGNED	ORIGINAL SIGNED
Engineering Manager		ORIGINAL SIGNED	ORIGINAL SIGNED

Table 1: Safety Critical Shutdown Valves

Protected Equipment Tag	Flammable Inventory ID	Description	Shutdown Valve Tag
10V1120	G05	Test Separator 10V1120 Inlet Shutdown Valve Test Separator 10V1120 Water Outlet Shutdown Valve Test Separator 10V1120 Oil Outlet Shutdown Valve Test Separator 10V1120 Gas Outlet Shutdown Valve	13-SDV-5101 10-SDV-5102 10-SDV-5103 10-SDV-5104
10V1100	G03	Production Separator No. 1 10V1100 Inlet Shutdown Valve Production Separator No. 1 10V1100 Water Outlet Shutdown Valve Production Separator No. 1 10V1100 Oil Outlet Shutdown Valve Production Separator No. 1 10V1100 Gas Outlet Shutdown Valve	13-SDV-5111 10-SDV-5112 10-SDV-5113 10-SDV-5114
10V1150	G04	Production Separator No. 2 10V1150 Inlet Shutdown Valve Production Separator No. 2 10V1150 Water Outlet Shutdown Valve Production Separator No. 2 10V1150 Oil Outlet Shutdown Valve Production Separator No. 2 10V1150 Gas Outlet Shutdown Valve	13-SDV-5121 10-SDV-5122 10-SDV-5123 10-SDV-5124
10V1300	G14	Production Separator No. 3 10V1300 Inlet Shutdown Valve Produced Water from Test Separator Production Separator No. 3 10V1300 Water Outlet Shutdown Valve Production Separator No. 3 10V1300 Oil Outlet Shutdown Valve Production Separator No. 3 10V1300 Gas Outlet Shutdown Valve	13-SDV-5034 12-SDV-5335 10-SDV-5019 10-SDV-5024 10-SDV-5029
10V1190	G13	2nd Stage Separator 10V 1190 Inlet Shutdown Valve 2nd Stage Separator 10V 1190 Water Outlet Shutdown Valve 2nd Stage Separator 10V 1190 Oil Outlet Shutdown Valve	10-SDV-5171 10-SDV-5172 10-SDV-5173
11U4000	G06	1st Stage Suction Scrubber Inlet Shutdown Valve 1st Stage Suction Scrubber Inlet Shutdown Valve 1st Stage Suction Scrubber Liquid Outlet Shutdown Valve 2nd Stage Suction Scrubber Liquid Outlet Shutdown Valve Discharge Scrubber Gas Outlet Shutdown Valve Discharge Scrubber Liquid Outlet Shutdown Valve	11-SDV-5361 11-SDV-5362 11-SDV-5363 11-SDV-5371 11-SDV-5375 11-SDV-5377
11U4200	G09	Recovered Gas Compressor Gas Inlet Shutdown Valve Recovered Gas Compressor Gas Outlet Shutdown Valve	11-SDV-5400 11-SDV-5401
37U6000	G10	Fuel Gas Scrubber 37V6010 Inlet Shutdown Valve (GLC) Fuel Gas Scrubber 37V6010 Inlet Shutdown Valve (VRC) Fuel Gas Scrubber 37V6010 Liquid Outlet Shutdown Valve GLC Fuel Gas Inlet GT1 Fuel Gas Inlet GT2 Fuel Gas Inlet	37-SDV-5720 37-SDV-5731 37-SDV-5722 37-SDV-5380 37-SDV-5860 37-SDV-5870
		Instrument Air System	38-SDV-5823 39-SDV-5810

Table 2: Safety Critical Riser Shutdown Valves

Protected Equipment Tag	Flammable Inventory ID	Description	Shutdown Valve Tag
116PIPE	G01-GL1 GL1-GA1	WNB Gas Lift Riser SDV WNA Gas Lift Riser SDV	11-RSDV-5426 14-SDV-1078



TITLE:	INTEGRATED CONTROL SYSTEM	DOC ID:	WAN-WNAB-CE-DC-07	RESPONSIBLE:	FACILITY ENGINEER
---------------	---------------------------	----------------	-------------------	---------------------	-------------------

SAFETY GOAL:	Control
OBJECTIVE:	To generate appropriate executive actions upon receipt of an initiating event
MAEs & CEEs:	All MAEs and CEE-01
SCOPE:	Inclusions:
	<ul style="list-style-type: none"> All control systems and logic solvers from receipt of initiating signal from safety critical field devices through to signal output to safety critical end users such as valves, pumps, compressors, etc.
SCOPE:	Exclusions:
	<ul style="list-style-type: none"> Fire & gas detection systems are covered under WAN-WNAB-CE-DC-01 Shut down systems are covered under WAN-WNAB-CE-DC-03 ICS functions not associated with other Safety Critical Elements are excluded from scope. Note, however, that these still have non-critical environmental performance requirements.

FUNCTIONALITY						
Key Component	Key Requirement	Performance Criteria	Assurance Activity	Minimum Frequency	Assurance Task	Reference
WAN-WNAB-CE-DC-07 ICS	To generate appropriate executive actions upon receipt of an initiating event	<ul style="list-style-type: none"> On receipt of signal from field initiators ICS shall operate and send an output signal in accordance with the Cause and Effects 	<ul style="list-style-type: none"> Function Test 	12M	A0001129; B-833.01 I/CFT-12 A0001130; B-833.02 I/CFT-12	[1][2][3][4][5]
		<ul style="list-style-type: none"> Upon activation of any initiator, a visual and audible alarm (in WNB CCR for WNA), clearly indicating the affected system / process / zone, shall be initiated 	<ul style="list-style-type: none"> Function Test 	12M	Refer to function testing of initiating and mitigation devices under WAN-WNAB-CE-DC-01 and WAN-WNAB-CE-DC-02	[1][2]

AVAILABILITY / RELIABILITY						
Key Component	Key Requirement	Performance Criteria	Assurance Activity	Minimum Frequency	Assurance Task	Reference
WAN-WNB-CE-DC-07 All Systems	System availability	<ul style="list-style-type: none"> Functional criteria to be available 100% of the time when system is in service 	<ul style="list-style-type: none"> By design 			[1]
WAN-WNB-CE-DC-07 F&G Logic	System availability	<ul style="list-style-type: none"> There shall be sufficient F&G initiators to comply with Cause and Effects voting logic requirements 	<ul style="list-style-type: none"> By design 			[2][5]
WAN-WNB-CE-DC-07 All Systems	System reliability	<ul style="list-style-type: none"> No specific reliability criteria defined 	<ul style="list-style-type: none"> N/A 			

SURVIVABILITY						
Key Component	Key Requirement	Performance Criteria	Assurance Activity	Minimum Frequency	Assurance Task	Reference
WAN-WNB-CE-DC-07 All Systems	<ul style="list-style-type: none"> No specific survivability requirement, failure of any element will be recorded as a fault and executive actions initiated. 	<ul style="list-style-type: none"> N/A 	<ul style="list-style-type: none"> 			

INTERDEPENDENCY			
Control Measure	Input / Output	Explanation	
WAN-WNAB-CE-DC-01	Input	F&G detection systems required to provide inputs to ICS	
WAN-WNAB-CE-DC-02	Input	Instrument protective and alarm systems required to provide inputs to ICS	
WAN-WNAB-CE-DC-03	Output	ICS required to initiate shutdown	
WAN-WNAB-CE-DC-04	Output	ICS required to initiate blowdown	
WAN-WNAB-CE-MI-02	Output	ICS required to initiate AFP	
WAN-WNAB-CE-MI-03	Output	ICS required to initiate HVAC shutdown	
WAN-WNAB-CE-ES-01	Input	UPS required for provision of power ICS	

DOCUMENT REFERENCES			
Ref	Document No.	Document Title	Section/Chapter/Page
[1]	WPA-7000-YG-1004	Fire & Safety Systems Integrity Manual	
[2]	WNB-3000-DY-4001	Cause and Effects – WNB – Fire & Gas	Dwg 4001.01 to 40097.01
[3]	WNB-3000-DP-4001	Cause and Effects – WNB – Process	Dwg .01 to .35
[4]	WNB-4000-DP-4000.01	Cause and Effects – WNA – Process	
[5]	WNB-4000-RY-0001	Cause and Effects – WNA – Fire & Gas	



TITLE:

INTEGRATED CONTROL SYSTEM

DOC ID:

WAN-WNAB-CE-DC-07

RESPONSIBLE:

FACILITY ENGINEER

DOCUMENT CONTROL HISTORY

Revision	Description	Comments	Date
0	Issued for Use		12 August 2016

APPROVALS

Role	Name	Signature	Date
HSES Advisor		ORIGINAL SIGNED	ORIGINAL SIGNED
Asset Integrity Advisor		ORIGINAL SIGNED	ORIGINAL SIGNED
Facility Engineer		ORIGINAL SIGNED	ORIGINAL SIGNED
Field Superintendent		ORIGINAL SIGNED	ORIGINAL SIGNED
Operations Manager		ORIGINAL SIGNED	ORIGINAL SIGNED



TITLE:	EMERGENCY COMMUNICATIONS	DOC ID:	WAN-WNAB-CE-ES-02	RESPONSIBLE:	FACILITY ENGINEER
---------------	--------------------------	----------------	-------------------	---------------------	-------------------

SAFETY GOAL:	Emergency System
OBJECTIVE:	To provide sufficient and diverse means and arrangements for communicating with personnel on the installation and appropriate external bodies
MAEs & CEEs:	All MAEs, CEE-01 and CEE-03
SCOPE:	Inclusions: <ul style="list-style-type: none"> UHF, and VHF radios, including (as applicable): <ul style="list-style-type: none"> Fixed and portable Aviation Marine WNA / WNB communications Public Address (PA) and Alarm systems, including: <ul style="list-style-type: none"> Alarm annunciation PA & Alarm Loudspeakers Cables Protection PA System
	Exclusions: <ul style="list-style-type: none"> Navigational aids are covered under WAN-WNAB-CE-PR-06 Instrument protective/alarm systems are covered under WAN-WNAB-CE-DC-02 Lifeboat communications covered under WAN-WNAB-CE-ES-04 - Escape, TR and Evacuation WRC communications covered under WAN-WNAB-CE-ES-05 Rescue and Recovery

FUNCTIONALITY						
Key Component	Key Requirement	Performance Criteria	Assurance Activity	Minimum Frequency	Assurance Task	Reference
WAN-WNAB-CCE-ES-02-01 UHF/VHF Radios	To ensure communication between CCR and the Emergency Response Team (at any location on the installations), personnel on WNA, personnel on CALM Buoy and external parties	Handheld VHF and UHF radios shall be in good working order	Inspection & Function Test	12M	A0001000; B-840.13 E/IN-12	[1][2][3]
		Antennae and repeaters shall ensure UHF signal is adequate at any location on the installations	Inspection & Function Test	12M	A0000987; B-840.00 E/IN-12 A0001003; B-840.16 E/IN-12 A0001004; B-840.17 E/IN-12 A0001005; B-840.18 E/IN-12	[1][2][3]
WAN-WNAB-CCE-ES-02-02 Alarm Loudspeakers/bell	To ensure that all personnel on board WNA and WNB in normally accessible areas are made aware of any need for mustering or abandonment	In all normally accessible areas of WNA and WNB, with the exception of the PLQ/XLQ, the alarm loudspeakers/bell shall provide a sound level between 65dBA and 105dBA and at least 6dBA above the average ambient sound level.	Function Test (PS005)	24M	A0001777; B-999.30 M/PM-24	[6]
		Inside the PLQ/XLQ the alarm loudspeakers shall provide a sound level between 75dBA and 105dBA.	Function Test (PS005)	24M	A0001777; B-999.30 M/PM-24	[6]
WAN-WNB-CCE-ES-02-03 Public Address System	To ensure that all personnel on board WNB in normally accessible areas are made aware of emergency public address broadcasts	In normally accessible areas of WNB the PA System announcements shall be audible and understandable.	Inspection & Function Test (PS005)	24M	A0001777; B-999.30 M/PM-24	[6]

AVAILABILITY / RELIABILITY						
Key Component	Key Requirement	Performance Criteria	Assurance Activity	Minimum Frequency	Assurance Task	Reference
WAN-WNAB-CE-ES-02-01 CALM Buoy	System availability	At least two forms of communication will be available to communicate with personnel on the CALM Buoy				[2][3]
WAN-WNAB-CE-ES-02-01 UHF Radios	System availability	On WNB there shall be a minimum of 8 functional handheld UHF radios and a minimum of 2 on WNA when manned				[2][3]
WAN-WNAB-CE-ES-02-01 VHF Radios	System availability	A minimum of 1 VHF radio is available on each platform when manned				[2][3]
WAN-WNB-CE-ES-02-03 Public address system	System availability	PA system shall be available during an ESD2, ESD1 or ESD0				[2][3]
WAN-WNA-CCE-ES-02-02 Alarm WAN-WNA-CCE-ES-02-03 Public Address System	System availability	All loudspeaker locations on WNB are covered by 2 loudspeakers on separate circuits				[2][3]
WAN-WNB-CCE-ES-02 All Systems	System reliability	No specific reliability criteria defined				[2][3]

SURVIVABILITY						
Key Component	Key Requirement	Performance Criteria	Assurance Activity	Minimum Frequency	Assurance Task	Reference
WAN-WNB-CCE-ES-02 All Systems	No specific survivability criteria – survivability assured through redundancy of communication types					[2][4][5]

INTERDEPENDENCY		
Control Measure	Input / Output	Explanation
WAN-WNAB-CE-PR-09	Input	Electrical distribution required for provision of power to emergency communication systems in the accommodation and TR.
WAN-WNAB-CE-ES-01	Input	Essential Power required for provision of power to emergency communication systems in the accommodation and TR



TITLE: EMERGENCY COMMUNICATIONS **DOC ID:** WAN-WNAB-CE-ES-02 **RESPONSIBLE:** FACILITY ENGINEER

INTERDEPENDENCY

Control Measure	Input / Output	Explanation
WAN-WNAB-CE-ES-04	Output	Emergency communications required to ensure TR command and control functionality
WAN-WNAB-CE-ES-05	Output	Emergency communications required to aid in rescue and recovery

DOCUMENT REFERENCES

Ref	Document No.	Document Title	Section/Chapter/Page
[1]	WPA-7000-YG-1008	Communications Integrity Manual	
[2]	WNB-3000-RH-0018	WNB Escape, TR, Evacuation and Rescue Analysis (ETRERA)	
[3]	WNB-4000-RH-0006	WNA Escape, Evacuation and Rescue Analysis (EERA)	
[4]	WNB-3000-RH-0019	WNB Emergency Systems Survivability Analysis (ESSA)	
[5]	WNB-4000-RH-0007	WNA Emergency Systems Survivability Analysis (ESSA)	
[6]	AS 60849:2004	Sound systems for emergency purposes	

DOCUMENT CONTROL HISTORY

Revision	Description	Comments	Date
0	Issued for Use		12 August 2016

APPROVALS

Role	Name	Signature	Date
HSES Advisor		ORIGINAL SIGNED	ORIGINAL SIGNED
Asset Integrity Advisor		ORIGINAL SIGNED	ORIGINAL SIGNED
Facility Engineer		ORIGINAL SIGNED	ORIGINAL SIGNED
Field Superintendent		ORIGINAL SIGNED	ORIGINAL SIGNED
Operations Manager		ORIGINAL SIGNED	ORIGINAL SIGNED

SAFETY & ENVIRONMENTAL CRITICAL PROCEDURE PERFORMANCE STANDARD



TITLE:	ELEMENT 6 – OPERATIONS & MAINTENANCE – INTEGRITY MANAGEMENT		
CODE:	WAN-WNAB-CP-PR-04	RESPONSIBLE	Matt Stichnoth
SAFETY GOAL	To mitigate the risk of SCE integrity failure through implementation of effective administrative systems		
OBJECTIVE:	To ensure the ongoing integrity of Wandoo facility SCEs, whose failure have the potential to result in an MAE		
MAEs & MEHs:	MAEs 1-8 and CEEs		
SCOPE:	Inclusions:		
	<ul style="list-style-type: none"> • Covers all Wandoo SCE assets, which in the event of an integrity failure, have the potential to result in an MAE or CEE, including: <ul style="list-style-type: none"> ○ WNA and WNB structural steel ○ Helipad ○ All safety critical hydrocarbon containing equipment • The following Safety Critical Procedure is covered by this scope: <ul style="list-style-type: none"> ○ Asset Integrity [1] 		
SCOPE:	Exclusions:		
	<ul style="list-style-type: none"> • Integrity of the well down-hole • Integrity of cranes is covered under WAN-WNAB-CCP-PR-05-PS Lifting Management • The impact of changes on SCEs is covered by Element 5 – Management of Change Safety and Environmental Critical Procedure Performance Standard 		

FUNCTIONALITY				
Key Component	Key Requirement	Performance Criteria	Assurance Activity	Reference
WAN-WNAB-CP-PR-04-01 SCE and PS identification	SCEs are identified and have established performance requirements that ensure their ongoing integrity and effectiveness	<ul style="list-style-type: none"> • SCEs are identified as part of the FSA process • Performance Standards are defined for each SCE 	<ul style="list-style-type: none"> • HSEMS audits of Element 6 – Integrity Management are conducted in accordance with the HSEMS Element 12 – Performance Assessment Manual [2] • SCE Performance Standards • Asset Register 	<ul style="list-style-type: none"> • OPGGS (Safety) Act 2006 • OPGGS (Safety) Regulations 2009
WAN-WNAB-CP-PR-04-02 Inspection, maintenance, monitoring and testing	Integrity management systems provide for the inspection, maintenance, monitoring and testing of CEs to identify deterioration and ensure ongoing integrity	<ul style="list-style-type: none"> • SCE inspection, maintenance, monitoring and testing: <ul style="list-style-type: none"> ○ Meets the minimum requirements specified by recognised relevant industry codes and standards ○ Is incorporated into work plans and schedules • A sound basis exists for the criteria for selection of SCE inspection and test intervals, such as: <ul style="list-style-type: none"> ○ Equipment history ○ Oil and gas industry standards and experience ○ Manufacturer's recommendations ○ Risk based methodologies 	<ul style="list-style-type: none"> • HSEMS audits of Element 6 – Integrity Management are conducted in accordance with the HSEMS Element 12 – Performance Assessment Manual [2] 	<ul style="list-style-type: none"> • OPGGS (Safety) Act 2006 • OPGGS (Safety) Regulations 2009 • Asset Integrity [1]
WAN-WNAB-CP-PR-04-03 Critical Function Tests	Integrity management systems ensure that critical devices are tested so no failures occur that could result in an MAE or CEE	<ul style="list-style-type: none"> • A critical function testing management system is established that provides for: <ul style="list-style-type: none"> ○ The identification of critical devices ○ The method of function testing critical devices ○ A procedure that provides for the function testing of critical devices ○ The pass / fail criteria for critical function testing ○ The determination of SIL and availability targets for critical devices ○ Defining intervals for critical function testing 	<ul style="list-style-type: none"> • HSEMS audits of Element 6 – Integrity Management are conducted in accordance with the HSEMS Element 12 – Performance Assessment Manual [2] 	<ul style="list-style-type: none"> • Asset Integrity [1]

EFFECTIVENESS				
Key Component	Key Requirement	Performance Criteria	Assurance Activity	Reference
WAN-WNAB-CP-PR-04-04 Integrity Management	The integrity of SCEs is maintained at all times	<ul style="list-style-type: none"> Inspection, maintenance, monitoring and testing activities are completed in accordance with the Asset Integrity Management System Integrity assurance activities demonstrate that SCE performance is in compliance with SCE Performance Standards performance criteria SCEs that are identified as having deviated from their performance criteria are either rectified immediately or subject to a Deviation Risk Assessment 	<ul style="list-style-type: none"> HSEMS audits of Element 6 – Integrity Management are conducted in accordance with the HSEMS Element 12 – Performance Assessment Manual [2] HSEMS audits of Element 3 – Risk Assessment are conducted in accordance with the HSEMS Element 12 – Performance Assessment Manual [2] Integrity program annual review Review and appraisal of KPIs Review of EAMS work orders & verification activities Deviation Risk Assessment records Inspection and NDT database Review of ITPs 	<ul style="list-style-type: none"> Asset Integrity [1] Element 3 – Risk Assessment Safety & Environmental Critical Procedure Performance Standard

INTERDEPENDENCY		
Control Measure	Input / Output	Explanation
WAN-WNAB-CP-PR-02 Element 4 – Management of Change	Input	Changes that may affect the integrity of SCEs must be managed to ensure the SCEs remain effective
WAN-WNAB-CP-ALL-01 Element 5 – Training and Competency	Input	Personnel must be appropriately trained and competent to ensure integrity management systems are effectively implemented
All SCEs	Output	Integrity management systems provide assurance that SCEs remain effective

DOCUMENT REFERENCES		
Ref	Document No.	Document Title
[1]	VOG-1000-MN-0006	Asset Integrity
[2]	VOG-1100-YG-1201	Performance Assessment

DOCUMENT CONTROL HISTORY			
Revision	Description	Comments	Date
A	Issued for review	Initial issue	12 January 2015
0	Issued for use		29 January 2015
1	Issued for use	Revision to formatting	9 September 2016

APPROVALS			
Role	Name	Signature	Date
HSES Advisor		ORIGINAL SIGNED	ORIGINAL SIGNED
Asset Integrity Engineer		ORIGINAL SIGNED	ORIGINAL SIGNED
Facilities Engineer		ORIGINAL SIGNED	ORIGINAL SIGNED
Field Superintendent		ORIGINAL SIGNED	ORIGINAL SIGNED
Operations Manager		ORIGINAL SIGNED	ORIGINAL SIGNED

SAFETY & ENVIRONMENTAL CRITICAL PROCEDURE PERFORMANCE STANDARD



TITLE:	WELL CONSTRUCTION – WELL CONTROL		
CODE:	WAN-WNAB-CP-PR-06	RESPONSIBLE	Nick Muecke
SAFETY GOAL:	To execute well construction and intervention campaigns in a manner to prevent loss of well integrity.		
OBJECTIVE:	To ensure that systems and processes exist for the effective management of risks associated with MAEs or CEEs for Wandoo facility operations		
MAEs & CEEs:	MAE-01 and CEE-01		
SCOPE:	Inclusions:		
	<ul style="list-style-type: none"> • Well Construction Management System (WCMS) including: <ul style="list-style-type: none"> ○ Well Construction Management System Manual (WCMSM) [1]; ○ Well Construction Process Manual (WCPM) [2]; and ○ Well Construction Standards Manual (WCSM) [3]. 		
SCOPE:	Exclusions:		
	<ul style="list-style-type: none"> • Nil 		

FUNCTIONALITY			
Key Component	Key Requirement	Performance Criteria	Assurance
WAN-WNAB-CP-PR-06-01 Risk Management	For all campaigns, all known residual risks shall be reduced to ALARP.	<ul style="list-style-type: none"> • The well construction Risk Management Process [2] will be followed for all well construction and well intervention activities. • Risks and controls are recorded and maintained in the Project Risk Register and Campaign specific HAZID workshops reports. • Campaign specific Commitment Register [5] identifies all commitments made under the WCMS, Campaign specific Safety Case Revisions, Well Construction Environment Plan and other relevant Campaign documents. 	<ul style="list-style-type: none"> • Well construction management system, which contains specific direction on risk management and change management, is followed during the planning, execution and wrap up of all campaigns. • Known hazards associated with well construction and intervention activities are evaluated as part of VOGA's ongoing risk review process. These hazards along with identified mitigation barriers / controls and contingency plans are captured in the Project specific Risk Register [4] and any necessary risk controls are reflected in the Well Construction or Intervention Programme [4]. • The Commitment Register is reviewed on a weekly basis by the VOGA Well Construction Manager and the VOGA Well Construction HSE Adviser to ensure commitments are being met.
WAN-WNAB-CP-PR-06-02 Contracting and Procurement	Contracting and procurement of equipment and services for the execution of well construction activities ensures contractors retained for VOGA's well construction activities have robust management systems.	<ul style="list-style-type: none"> • All contracting and procurement processes are carried out in accordance with the VOGA Contractor / Vendor Selection and Management Manual [6]. • The WCSM [3] specifies minimum equipment standards for critical equipment for well construction. • The Procurement and Logistics Process [2] shall be followed for well construction campaigns. • The VOGA Contractor / Vendor Selection and Management Manual [5] risk assessment process will be implemented. 	<ul style="list-style-type: none"> • Contractors will be risk ranked to determine against safety, environmental or project impact criteria. Companies having a medium or high risk ranking will be deemed as critical. • QHSE questionnaires will be completed by all contractors. • VOGA contractor / pre-hire inspections and audits for critical contractors as per Campaign specific QHSE Plan [7]. • Third party inspectors are used to verify the application of vendor QA/QC processes for all critical equipment and to confirm the equipment meets VOGA's specifications. • Third party inspectors are used prior to the shipment of critical rental equipment to ensure the vendor QA/QC processes are followed and to confirm the equipment meets VOGA's specifications. • Third party inspector CVs are reviewed and accepted by VOGA.
WAN-WNAB-CP-PR-06-03 Emergency Response	Emergency response and management procedures, resources and training shall be in place to enable effective responses to emergency incidents.	<ul style="list-style-type: none"> • VOGA Well Construction Emergency Response Plan [8] will be in place and shall include defined responses to address foreseeable emergency scenarios (including loss of well control). • A VOGA Source Control Contingency Plan [9] shall be in place to guide the required response in the event of a major well control incident during well construction and/or intervention operations. • Emergency response plans of the Drilling Contractor (including well control) will be bridged and aligned with the VOGA Well Construction Emergency Response Plan. • Drills (including well control) will be carried out in accordance with the MODU Safety Case and Campaign specific QHSE Plan. • Emergency response elements of the campaign specific Facility Safety Case Revisions, SIMOPS Plan (if relevant), Emergency Response Plan, QHSE Plan, Well Construction Environment Plan will be covered during the Campaign induction processes. 	<ul style="list-style-type: none"> • Emergency response drills and exercises will be conducted during the planning and operations stages of the campaign as detailed in the QHSE Plan. • Emergency Response training will be carried out prior to the commencement of a well construction campaign as per project specific QHSE Plan. • The Well Construction Team shall receive inductions on the VOGA Source Control Contingency Plan prior to the commencement of a well construction campaign. • All blow-out prevention drills and their response times will be recorded in the IADC report and the Daily Drilling Report. • The Campaign specific Commitment Register identifies the commitments made for the Project in relation to the Emergency Response Plan. • The Campaign specific Commitment Register is reviewed on a weekly basis by the VOGA Well Construction Manager and the VOGA Well Construction HSE Adviser to ensure commitments are being met.

FUNCTIONALITY			
Key Component	Key Requirement	Performance Criteria	Assurance
WAN-WNAB-CP-PR-06-04 Primary Well Control	Well control shall be maintained at all times during well construction and intervention operations.	<ul style="list-style-type: none"> Primary well control will be maintained at all times. The optimum method of regaining primary well control will be selected following an influx, based on an evaluation of the prevailing circumstances. Minimum parameters to be monitored during operations are detailed in the WCSM. Monitoring equipment shall be available on the rig to enable personnel to evaluate well control status. Monitoring equipment shall be maintained in accordance with the Drilling Contractor's or third party service provider's (as appropriate) preventative maintenance system. 	<ul style="list-style-type: none"> The VOGA Mud Logging Services contract and the Drilling Rig Contract define the scope of work and equipment to be provided under relevant contract. Pre-start MODU inspection and audit processes ensure monitoring equipment is present and that it is managed under the relevant contractor's preventative maintenance system. The VOGA Rig Inspection Checklist (which includes confirmation that monitoring equipment is in place and working) has been completed prior to commencement of well work. The VOGA Mud Logging Checklist (which includes confirmation that monitoring equipment is in place and working) has been completed prior to commencement of well work. Personnel certification will be current (refer to WAN-WNAB-CP-PR-06-09). The VOGA Line Of Sight will include MODU and service contractor well control Safety Critical Elements.
WAN-WNAB-CP-PR-06-05 Secondary Well Control Equipment	Well Control Equipment and Pressure Control Equipment shall be appropriate for providing control of the well.	<ul style="list-style-type: none"> Well Control Equipment will comply with API RP 53 [10]. All Well Control Equipment, except annular type BOPs, will have sufficient working pressure rating to contain the greatest anticipated shut-in surface pressure from total depth of that hole section. The minimum configuration for Well Control Equipment and Pressure Control Equipment will be as detailed in the WCSM. All Well Control Equipment will be tested in accordance with the manufacturer's recommendations using the Drilling Contractor's procedures. Well design will be carried out in accordance with the WCPM to ensure that the well is capable of withstanding the maximum anticipated surface pressure. 	<ul style="list-style-type: none"> The VOGA Rig Inspection Checklist, which includes confirmation that Well Control Equipment is available and in serviceable condition, is completed. VOGA audits contractors to ensure Well Control Equipment and Pressure Control Equipment is provided (in compliance with the relevant standard) and that the contractor preventative maintenance system includes their Well Control Equipment and Pressure Control Equipment. Well Control Equipment / Pressure Control Equipment testing requirements as defined in the WCSM have been met and the relevant testing has been verified by a senior member of the Drilling Contractor and VOGA offshore supervisory teams. A fit for purpose well design will be confirmed through the review processes defined in the WCPM.
WAN-WNAB-CP-PR-06-06 Well Barrier Elements	Casing and other well equipment shall be designed to contain any anticipated pressure during the lifecycle of the well.	<ul style="list-style-type: none"> Casing and Tubing Properties will meet the requirements of API Spec 5CT [11] and API Spec 5D [12]. Inspection of Casing and Tubing will meet the requirements of API RP 5A5 [13]. Thread compounds used for making up Casing and Tubing will meet the requirements of API RP 5A3 [14]. Transportation and handling of Casing and Tubing will meet the requirements of API RP 5C1 [15] and the Well Construction Lifting Equipment Guidelines [16]. Subsurface Safety Valves will meet the requirements of API 14A [17] and API 14B [18]. Wellhead and Christmas Tree specifications will meet the requirements of API 6A [19] and API 17D [20] as appropriate. Production Packers will meet the requirements of ISO/DIS 14310 [21]. Landing Nipples will meet the requirements of ISO/DIS 16070 [22]. Gas Lift Mandrels and Gas Lift Valves will meet the requirements of ISO 17078-1 [23] and ISO 17078-3 [25]. Production Packers and Bridge Plugs will meet the requirements of ISO/DIS 14310 [25]. Hydraulic control fluid will meet the requirements of SAE AS 4059 [25]. 	<ul style="list-style-type: none"> Contracting and procurement of equipment and services (refer to WAN-WNAB-CP-PR-06-02). Barrier specifications (refer to WAN-WNAB-CP-PR-06-08). A fit for purpose well design will be confirmed through the review processes defined in the WCPM.
WAN-WNAB-CP-PR-06-07 Cement	All cement slurries when designed to act as barriers shall, following implementation, result in the cured cement providing a barrier which meets the barrier specifications defined in the WCSM.	<ul style="list-style-type: none"> Every well or campaign, which requires cementing operations, will have a cement programme. All cement slurries that are designed to act as barriers will be designed and tested by the cementing contractor to meet downhole well conditions. Prior to any cementing operation, laboratory testing of each slurry design will be conducted in accordance with API Spec 10A [26]. 	<ul style="list-style-type: none"> Contractor verifies that laboratory testing is conducted in accordance with API Spec 10A. Cementing process, including mixing and pumping pressures, are monitored throughout each job and the results are detailed in reports issued by the cementing contractor and VOGA supervisory team. Slurry samples will be taken during the mixing process for quality control assurance (slurry samples are not kept post job). The results of cementation operations will be verified by a senior member of the Drilling Contractor and VOGA offshore supervisory teams to confirm that VOGA's barrier specifications have been met (refer to WAN-WNAB-CP-PR-06-08).
WAN-WNAB-CP-PR-06-08 Well barriers	Well barriers are designed to contain anticipated pressure during the lifecycle of the well and shall be installed in accordance with the WCSM.	<ul style="list-style-type: none"> Barriers and their verification requirements will meet the specifications defined in the WCSM. Barriers and their verification requirements will be specified in operational programmes. Barrier testing procedures will meet the specifications detailed in the WCSM. VOGA's WCSM specifies the barriers that will be in place during well construction and intervention activities: <ul style="list-style-type: none"> Two temporary barriers will be in place for all well construction and intervention operations unless otherwise specified in the Well Construction or Intervention Programme or approved under the VOGA WC Change Management Process. Operational programmes approved at Well Construction Manager level or above may specify deviations to the WCSM. In other circumstances, where deviations are required, they shall be controlled under the Change Management Process. If a barrier fails, immediate action will be taken to reinstate, replace or supplement the barrier so that VOGA barrier requirements are maintained. Following suspension or abandonment operations, two verified barriers will be present in the annulus and well bore above any permeable hydrocarbon or over a pressured zone. 	<ul style="list-style-type: none"> The placement of barriers and the results of the testing process shall be verified by a senior member of the Drilling Contractor and VOGA offshore supervisory teams. Barrier verifications shall be recorded on a Barrier Verification Sheet, which shall be signed off by a senior member of the Drilling Contractor and VOGA offshore supervisory teams. The status of well barriers, and their verifications as specified in the Well Construction Programme, are detailed and signed off in the Well Handover Form at the end of the project. Whenever the status of the barriers change, the barrier verification process shall be recorded on a Barrier Verification Sheet, which shall be signed off by a senior member of the Drilling Contractor and VOGA offshore supervisory teams.

FUNCTIONALITY			
Key Component	Key Requirement	Performance Criteria	Assurance
WAN-WNAB-CP-PR-06-09 Competency	All well construction and contractor personnel shall have appropriate certification for their assigned role.	<ul style="list-style-type: none"> • Drilling contractor personnel will be in possession of a valid Well Control Training Certificate from the IWCF, WellCAP or another equivalent accredited organisation: <ul style="list-style-type: none"> ○ Supervisory Level Certificate: all personnel in positions above Driller level; and ○ Driller Level Certificate: Driller, Assistant Driller, Derrickman. • The VOGA well construction group will have a competency management system, a training matrix and job descriptions. • VOGA Well Construction personnel shall be in possession of a valid and recognised Well Control Training Certificate, in accordance with the Well Construction Training Matrix. • Contractors shall have a competency and training system in place. • Contractor personnel shall be competent in accordance with their company's competency system. 	<ul style="list-style-type: none"> • VOGA contractor audits determine if the Drilling Contractor has a competency and training system in place and that the Drilling Contractor is compliant with the system and conducts system audits. • VOGA personnel records include copies of current certification for well construction personnel. • Well Construction Action Tracker, includes due dates for renewal of personnel certification. The Well Construction Action Tracker is reviewed at the Well Construction team weekly meeting. • Contractor personnel resumes are reviewed for certification and experience for their role in the Well Construction campaign.

EFFECTIVENESS			
Key Component	Key Requirement	Performance Criteria	Assurance
WAN-WNAB-CP-PR-06-10 Following the WCMS	The WCMS is followed for all well construction and intervention activities.	<ul style="list-style-type: none"> • The responsibilities and approval requirements are detailed in the WCPM to provide checks and confirmation that the required process has been implemented and that the appropriate standards have been applied. • The WCMS is reviewed on a bi-annual basis (or earlier if warranted) to capture changes in company and industry practices. • 3rd party companies are audited to confirm that they have systems in place for competent people and maintenance of tools which contributes to the planned outcome of the well construction activity. 	<ul style="list-style-type: none"> • The WCPM details the processes which are to be followed for each well construction activity with the outcome that the well is fit for purpose and will be available for its planned life. • The WCSM details equipment standards and requirements which ensures fit for purpose material and equipment is used to meet the planned life cycle of the well. • The VOGA Job Descriptions define the experience and qualifications requirements for roles within the Well Construction team. • The WCPM defines the competence management process to be applied within the Well Construction team.
WAN-WNAB-CP-PR-06-11 Applying the WCMS	The WCMS shall be applied to all well construction and intervention activities.	<ul style="list-style-type: none"> • Quality assurance checks are performed on equipment or rented tools critical to well integrity before they are shipped from the manufacturer or prior to departure from the supplier's Australian facility. • Internal VOGA reviews confirms compliance with the WCMS and includes: <ul style="list-style-type: none"> ○ Performance measurement, monitoring and reporting; ○ Change management approval; ○ Audits and inspections; ○ Corrective action tracking and close-out; ○ Management reviews ○ Known risks associated with well construction and intervention activities have been evaluated with any identified mitigation and contingency plans are captured in the Project specific Risk Register and are reflected in operational programmes. 	<ul style="list-style-type: none"> • The WCPM details the processes which are to be followed for each well construction activity with the outcome that the well is fit for purpose and will be available for its planned life. • The WCSM details equipment standards and requirements which ensures fit for purpose material and equipment is used to meet the planned life cycle of the well. • The VOGA Job Descriptions define the experience and qualifications requirements for roles within the Well Construction team. • The WCPM defines the competence management process to be applied within the Well Construction team.

INTERDEPENDENCY		
Control Measure	Input / Output	Explanation
WAN-WNAB-CP-ALL-01 Training and Competency	Input	Personnel must be trained and competent in the execution of risk assessment and management activities
WAN-WNAB-CP-PR-02 Management of Change	Output	Management of change processes require the assessment and management of risks associated with the change
WAN-WNAB-CP-PR-03 O&M - Work the Field	Output	Personnel need to apply risk management processes to operate the facility safely
WAN-WNAB-CP-PR-04 O&M – Integrity Management	Output	Personnel need to apply risk management processes to understand and assess facility integrity

DOCUMENT REFERENCES

Ref	Document No.	Document Title
[1]	VOG-5000-MN-0001	Well Construction Management System Manual
[2]	VOG-5000-MN-0002	Well Construction Process Manual
[3]	VOG-5000-MN-0003	Well Construction Standards Manual
[4]	[Campaign specific]	Well Construction or Intervention Programme
[5]	[Campaign specific]	Campaign specific Commitment Register
[6]	VOG-1000-MN-0001	VOGA Contractor / Vendor Selection and Management Manual
[7]	[Campaign specific]	Campaign specific QHSE Plan
[8]	VOG-5000-YH-0001	VOGA Well Construction Emergency Response Manual
[9]	VOG-5000-PD-0001	VOGA Source Control Contingency Plan
[10]	API RP 53	Recommended Practices for Blowout Prevention Equipment Systems for Drilling Wells
[11]	API Spec 5CT	Specification for Casing and Tubing
[12]	API Spec 5D	Specification for Drill Pipe
[13]	API RP 5A5	Field Inspection of New Casing, Tubing and Plain End Drill Pipe
[14]	API RP 5A3	Thread Compounds for Casing, Tubing and Line Pipe
[15]	API RP 5C1	Care And Use Of Casing And Tubing
[16]	VOG-5000-MN-0005	Well Construction Lifting Equipment Guidelines
[17]	API 14A	Specification for Subsurface Safety Valve Equipment
[18]	API 14B	Design Installation, Repair and Operation of Sub Surface Safety Valves
[19]	API 6A	Specification for Wellhead Equipment
[20]	API 17D	Design and Operation of Subsea Production Systems - Subsea Wellhead and Tree Equipment
[21]	ISO/DIS 14310	Downhole Equipment - Packers and Bridge Plugs
[22]	ISO/DIS 16070	Lock Mandrels / Landing Nipples - Flow Control
[23]	ISO 17078-1	Side Pocket Mandrels (1st Edition)
[24]	ISO 17078-3	Latches, Seals and Interface data for side pocket mandrels and flow control devices
[25]	SAE AS 4059	Aerospace Fluid Power - Cleanliness Classification For Hydraulic Fluids
[26]	API Spec 10A	Specification for Cements and Materials for Well Cementing

DOCUMENT CONTROL HISTORY

Revision	Description	Comments	Date
A	Issued for review	Initial issue	20 December 2012
B	Issued for review	Revised for compliance with WCMS	19 August 2016
0	Issued for Use	Issued for Use	12 September 2016

APPROVALS

Role	Name	Signature	Date
Well Construction Manager		ORIGINAL SIGNED	ORIGINAL SIGNED
Operations Manager		ORIGINAL SIGNED	ORIGINAL SIGNED

CRITICAL PROCEDURE PERFORMANCE STANDARD



TITLE:	ELEMENT 8 – EMERGENCY PREPAREDNESS, MANAGEMENT & RESPONSE		
CODE:	WAN-WNAB-CP-ER-01	RESPONSIBLE	Managing Director
SAFETY GOAL:	To mitigate the risk of an MAE or CEE during or following an emergency scenario		
OBJECTIVE:	To ensure that measures are in place to provide effective response in the event of an emergency situation at Wandoo facilities		
MAEs & CEEs:	All MAEs (1-9) and CEEs		
SCOPE:	Inclusions:		
	<ul style="list-style-type: none"> • Covers emergency response arrangements for all operations conducted in the Wandoo field and on the Wandoo facilities comprising WNA, WNB and marine systems • Environment response for all for all activities within the Wandoo Field. • The following Safety Critical Procedures are covered by this scope: <ul style="list-style-type: none"> ○ Emergency Response Plan [1] ○ Field Oil Spill Contingency Plan [2] ○ Platform Operations Manual VOG-7000-MN-0001 – TEMPSC Operations WNB-064-001 ○ Platform Operations Manual VOG-7000-MN-0001 – Work Rescue Craft Operations WNB-064-002 		
SCOPE:	Exclusions:		
	<ul style="list-style-type: none"> • ER arrangement relating to people and asset excludes the following activities: <ul style="list-style-type: none"> ○ MODU based Drilling, completions and well interventions; ○ Mobile facility based construction / installation, e.g. tie-in of new wells or subsea infrastructure; ○ Facility and subsea production system modifications; and ○ Field decommissioning and abandonment • CALM buoy rescue plans are covered under WAN-WNAB-CCP-ALL-02 Operations & Maintenance – Marine Operations 		

FUNCTIONALITY				
Key Component	Key Requirement	Performance Criteria	Assurance Activity	Reference
WAN-WNAB-CP-ER-01-01 ER Arrangements	Emergency response arrangements are adequate to manage identified emergency scenarios	<ul style="list-style-type: none"> • Emergency response arrangements: <ul style="list-style-type: none"> ○ Are described in detail for all MAEs and credible significant risks identified in the Wandoo Safety Case [4] ○ Define communication requirements for each response level (1, 2, or 3) and position in the emergency response organisation structure ○ Shall be maintained to ensure they are up to date and appropriate to the relevant emergency scenario ○ Require an emergency contact list to be maintained 	<ul style="list-style-type: none"> • HSEMS audits of Element 8 – Emergency Preparedness, Management and Response are conducted in accordance with the HSEMS Element 12 – Performance Assessment Manual [3] • The ERP includes all MAEs and credible significant risks identified in the Wandoo Safety Case [4] • Management of Change process considers impacts of changes on emergency response arrangements • The schedule of emergency drills in the Emergency Response Schedule [5] reflects the scenarios identified in the ERP • Post exercise and incident review of emergency response arrangements • Six monthly review of emergency contact list [6] 	<ul style="list-style-type: none"> • OPGGS (Safety) Regulations r.2.20 • Emergency Response Plan [1] • Performance Assessment Manual [3] • Wandoo Safety Case [4]
WAN-WNAB-CP-ER-01-02 OSR Arrangements	Oil spill response arrangements are adequate to manage identified oil spill scenarios	<ul style="list-style-type: none"> • Oil spill scenarios are documented, aligning with the scenarios identified in the Wandoo Facility Environment Plan (WPA-7000-YH-000) and provide the following information: <ul style="list-style-type: none"> ○ Types and approximate volumes of spill scenarios ○ Types of environmental impacts that may occur due to a spill ○ Potential areas of impact for different spill scenarios ○ Classification of the oil spill (tier 1 / tier 2 / tier 3) to allow an appropriate level of response ○ Response arrangements for identified spill scenarios ○ Compliance with requirements of relevant legislation, national codes, standards, guidelines and stakeholders ○ Organisational structure that applies in the event of an emergency ○ Roles and responsibilities for key oil spill response personnel 	<ul style="list-style-type: none"> • HSEMS audits of Element 8 – Emergency Preparedness, Management and Response are conducted in accordance with the HSEMS Element 12 – Performance Assessment Manual [3] • Oil spill response arrangements periodically reviewed and updated as part of the Oil Spill Response Capability Review [7] 	<ul style="list-style-type: none"> • Field Oil Spill Contingency Plan [2] • Performance Assessment Manual [3] • Oil Spill Response Capability Review [7]

FUNCTIONALITY				
Key Component	Key Requirement	Performance Criteria	Assurance Activity	Reference
WAN-WNAB-CP-ER-01-03 Organisation	Emergency / oil spill response organisational arrangements shall allow effective response management regardless of the scale of the emergency	<ul style="list-style-type: none"> The emergency / oil spill response organisational structures that apply in the event of an emergency: <ul style="list-style-type: none"> Are documented and incorporate corporate, offshore and shore based support Are commensurate with the scale of response (level 1 / level 2 / level 3) Are consistent with the Incident Command System (ICS) structure Identify the position or person responsible for implementing and supervising procedures in the event of an emergency / oil spill Clearly defines the roles and responsibilities of key emergency / oil spill response personnel 	<ul style="list-style-type: none"> The schedule of emergency drills in the Emergency Response Schedule [5] reflects the scenarios identified in the ERP The organisational arrangements in the ERP are periodically reviewed and updated Emergency response organisational structure is tested as part of emergency exercises 	<ul style="list-style-type: none"> OPGGS (Safety) Regulations r.2.8 Emergency Response Plan [1] VOGA Emergency Response Schedule [5]
WAN-WNAB-CP-ER-01-04 Personnel Competency	Emergency / oil spill response personnel shall be competent for the emergency role to which they are assigned	<ul style="list-style-type: none"> Emergency response arrangements and personnel emergency response capabilities are reinforced through execution of training and exercise programs, including: <ul style="list-style-type: none"> Emergency drills Communication tests Emergency equipment training Personnel orientation Mustering Oil spill response training requirements are documented and require : <ul style="list-style-type: none"> Core members of the OCT and Perth Incident Command teams are trained in emergency management techniques and procedures An annual oil spill scenario drill Emergency drills cover the range of MAEs and CEEs identified within the Wandoo Safety Case and Emergency Response Plan 	<ul style="list-style-type: none"> The schedule of emergency drills in the Emergency Response Schedule [5] reflects the scenarios identified in the ERP As specified in Element 5 – Training and Competency Safety & Environmental Critical Procedure Performance Standard 	<ul style="list-style-type: none"> OPGGS (Safety) Regulations r.2.8 OPGGS (Safety) Regulations r.2.20 Emergency Response Plan [1] Oil Spill Contingency Plan [2] VOGA Emergency Response Schedule [5]

EFFECTIVENESS				
Key Component	Key Requirement	Performance Criteria	Assurance Activity	Reference
WAN-WNAB-CP-ER-01-05 Arrangements are Accessible	Current emergency / oil spill response arrangements are accessible to all personnel in the event of an emergency / oil spill	<ul style="list-style-type: none"> Emergency / oil spill response documentation is up to date, maintained and readily available within VOGA Information Systems Hard copies of the current ERP / OSCP are available on site to all team members 	<ul style="list-style-type: none"> HSEMS audits of Element 8 – Emergency Preparedness, Management and Response are conducted in accordance with the HSEMS Element 12 – Performance Assessment Manual [3] 	<ul style="list-style-type: none"> OPGGS(Safety) Regulations r.2.11 Emergency Response Plan [1] Oil Spill Contingency Plan [2] Performance Assessment Manual [3]
WAN-WNAB-CP-ER-01-06 Arrangements are Understood	Emergency / oil spill response personnel understand and competently perform their emergency response roles	<ul style="list-style-type: none"> Drills and exercises shall be carried out to review the effectiveness of the plan Emergency / oil spill response personnel are competent in their required emergency response roles All personnel with roles within the Corporate Command Team, Incident Management Team and On Site Command Team have training appropriate to their roles All training courses and participation in drills and exercises are recorded in training records 	<ul style="list-style-type: none"> As specified in Element 5 – Training and Competency Safety & Environmental Critical Procedure Performance Standard Safety induction records Emergency training drills and exercises performed fortnightly in accordance with the Emergency Response Schedule [5] Debrief minutes are electronically filed on the facility LAN for each emergency drill 	<ul style="list-style-type: none"> OPGGS(Safety) Regulations r.2.8 Emergency Response Plan [1] Oil Spill Contingency Plan [2] Emergency Response Schedule [5]

INTERDEPENDENCY		
Control Measure	Input / Output	Explanation
WAN-WNAB-CP-ALL-01 Training and Competency	Input	Personnel are competent to perform their emergency response roles
WAN-WNAB-CE-ES-02 Emergency Communications	Input	To permit relaying of emergency instructions and coordination of emergency response actions
WAN-WNB-CE-ES-03-PS Emergency Lighting	Input	To enable personnel to muster and evacuate safely
WAN-WNAB-CE-ES-04 Escape and Evacuation	Input	To provide means of escape, muster and evacuation of personnel during emergency conditions
WAN-WNB-CE-ES-05 Rescue and Recovery Facilities	Input	To provide rescue and recovery capability in the event of a marine related incident
WAN-WNAB-CE-ES-07 Personnel Survival Equipment	Input	To aid escape and maximize the survival time and the chance of successful recovery of personnel

DOCUMENT REFERENCES

Ref	Document No.	Document Title
[1]	VOG-2000-RD-0017	Emergency Response Plan
[2]	WAN-2000-RD-0001	Field Oil Spill Contingency Plan
[3]	VOG-1100-YG-1201	Performance Assessment Manual
[4]	VOG-2000-RD-0024	Wandoo Safety Case
[5]	VOG-1100-YH-0001	Emergency Response Schedule
[6]	VOG-2000-RD-0050	Emergency Contacts List
[7]	VOG-7000-RH-0009	Oil Spill Response Capability Review

DOCUMENT CONTROL HISTORY

Revision	Description	Comments	Date
A	Issued for review	Initial issue	12 January 2015
0	Issued for use	Issued for use	29 January 2015
1	Issued for use	Revision to formatting	9 September 2016
2	Issued for use	Revision to Clarify Statement	5 February 2020
3	Issued for use	Issued for use	4 December 2020

APPROVALS

Role	Signature	Date
HSE Manager	SIGNATURE ON CHANGE APPROVAL FORM	DATE ON CHANGE APPROVAL FORM
Field Superintendent	SIGNATURE ON CHANGE APPROVAL FORM	DATE ON CHANGE APPROVAL FORM
Managing Director	SIGNATURE ON CHANGE APPROVAL FORM	DATE ON CHANGE APPROVAL FORM

CRITICAL PROCEDURE PERFORMANCE STANDARD



TITLE:	ELEMENT 8 – OIL SPILL RESPONSE		
CODE:	WAN-WNAB-CP-ER-02 and WAN-WNAB-CP-ER-03	RESPONSIBLE	Managing Director
GOAL:	To mitigate the environmental impacts as a result of oil spill.		
OBJECTIVE:	To ensure that measures are in place to mitigate the oil spill hazards associated with activities within the Wandoo Field.		
MAEs & CEEs:	All CEEs		
SCOPE:	Inclusions:	<ul style="list-style-type: none"> Covers oil spill response arrangements for all activities within the Wandoo Field. 	
	Exclusions:	<ul style="list-style-type: none"> Excludes oil spill response not associated with activities within the Wandoo Field. 	

FUNCTIONALITY				
Key Component	Key Requirement	Performance Criteria	Assurance Activity	Reference
WAN-WNAB-CP-ER-02-01 OSR Arrangements	The Wandoo Field OSCP is established to mitigate the oil spill hazards identified in the respective environment plan.	<ul style="list-style-type: none"> The Wandoo Field OSCP reflects the credible oil spill hazards (volume, duration and potential impact) associated with petroleum activities as outlined within the respective environment plan. To ensure that the loss of well control hazard for any new wells proposed in Wandoo Field remain within the worst-case discharge parameters (volume, duration and potential impact), new wells will be assessed using reservoir modelling prior to drilling. The Wandoo Field OSCP considers oil spill hazards within the context of the seasons for which the petroleum activity occurs, as described in the environment plan. All oil spill hazards identified in the environment plan are covered by an oil pollution plan (OPP) within the Wandoo Field OSCP. 	<ul style="list-style-type: none"> Accepted Wandoo Field OSCP [WAN-2000-RD-0001]. 	<ul style="list-style-type: none"> Wandoo Field OSCP [1]
	Response strategies provided in the OPPs are appropriate to: <ul style="list-style-type: none"> the nature and scale and associated environmental impact of the potential spill hazards; the nature and scale and associated environmental impact of the potential spill response strategies; and the environmental sensitivities and priorities as outlined within the respective environment plan. 	<ul style="list-style-type: none"> Response strategies described in the OPPs shall take into consideration the range of potential impacts from the spill events including: <ul style="list-style-type: none"> minimum time to contact; maximum length of shoreline contacted; maximum volume of oil ashore; geographical range of the trajectory of oil; and environmental sensitivities as outlined within the respective environment plan and their prioritisation based on recovery rates and uniqueness. The OPPs shall take into consideration the range of potential impacts from the identified response strategies including: <ul style="list-style-type: none"> the range of potential impact and recovery time for the environmental sensitivities; measures to reduce, manage or monitor environmental impact from the response as outlined within the respective environment plan; and event/ scenario specific environmental impact assessment of the spill and response activities prior to site implementation via Net Environmental Benefit Analysis. 	<ul style="list-style-type: none"> Accepted Wandoo Field OSCP [WAN-2000-RD-0001]. 	<ul style="list-style-type: none"> Wandoo Field OSCP [1]
	The Wandoo Field OSCP describes incident management system and interfaces.	<ul style="list-style-type: none"> Organisational structure and roles and responsibilities of Incident Control Team (ICT) members are defined in the Wandoo Field OSCP. Interfaces between the VOGA ICT and the command teams representing State and Commonwealth Oil Spill Response Agencies are described in the Wandoo Field OSCP. 	<ul style="list-style-type: none"> Accepted Wandoo Field OSCP [WAN-2000-RD-0001]. 	<ul style="list-style-type: none"> Wandoo Field OSCP [1]
	Decision making processes support mitigation of environmental impact of spills and assessment of effectiveness of response strategies.	<ul style="list-style-type: none"> The Wandoo Field OSCP shall provide a process for completing an Incident Action Plan (IAP) which shall include: <ul style="list-style-type: none"> an environmental impact assessment of the proposed response activities; selection of the most appropriate response activities (strategies); identification of appropriate operational and scientific monitoring activities; and operational and scientific monitoring outputs shall inform the effectiveness of response strategies. 	<ul style="list-style-type: none"> Accepted Wandoo Field OSCP [WAN-2000-RD-0001]. 	<ul style="list-style-type: none"> Wandoo Field OSCP [1]
	The Wandoo Field OSCP shall contain processes to assess, test and maintain arrangements to meet the Wandoo Field OSCP outcomes through: <ul style="list-style-type: none"> assurance processes; capability assessment; and 	<ul style="list-style-type: none"> Regular inspections and audits to ensure arrangements outlined shall be in place. Response requirements for equipment and personnel shall be assessed throughout the duration of a worst-case spill event response. Emergency contacts directory is maintained with current and relevant contact details for oil spill response. Oil Spill Response Capability Review [VOG-7000-RH-0009] updated annually to ensure oil spill response capabilities stated in the relevant EP and OSCP are maintained. 	<ul style="list-style-type: none"> Inspections of third-party providers undertaken in accordance with the Wandoo Field OSCP Part 3: Performance Management [WAN-2000-RD-0001]. 	<ul style="list-style-type: none"> Wandoo Field OSCP [1]

FUNCTIONALITY				
Key Component	Key Requirement	Performance Criteria	Assurance Activity	Reference
	<ul style="list-style-type: none"> review triggers. 	<ul style="list-style-type: none"> Oil spill response exercises shall: <ul style="list-style-type: none"> provide situational experience to ICT personnel and enabling them to be aware of their assigned roles and responsibilities during a response; assesses the effectiveness, achievability and timeliness of incident action planning for the duration of expected response; and test interfaces between teams and deployment of equipment and resources. 	<ul style="list-style-type: none"> Oil spill response exercises shall be undertaken in accordance with Table 8-2 of the Wandoo Field OSCP [WAN-2000-RD-0001]. Oil Spill Response Capability Review [VOG-7000-RH-0009] contains up-to-date capability assessment of equipment and personnel. 	<ul style="list-style-type: none"> Wandoo Field OSCP [1] Oil Spill Response Capability Review [2]
		<ul style="list-style-type: none"> The Wandoo Field OSCP shall identify review triggers linked to significant changes to spill risk profile and availability of equipment and personnel required within the OPPs. 	<ul style="list-style-type: none"> Accepted Wandoo Field OSCP [WAN-2000-RD-0001]. 	<ul style="list-style-type: none"> Wandoo Field OSCP [1]
WAN-WNAB-CP-ER-02-02 Resources defined and available in a timely manner	Equipment, services and personnel required for the first 20 days are identified within the OPPs.	<ul style="list-style-type: none"> Training and competency requirements of key response personnel and contractors shall be defined. Capability assessment shall be conducted to ensure the availability of equipment and personnel within the desired timeframe. 	<ul style="list-style-type: none"> Accepted Wandoo Field OSCP [WAN-2000-RD-0001]. Oil Spill Response Capability Review [VOG-7000-RH-0009] contains up-to-date capability assessment of equipment and personnel. 	<ul style="list-style-type: none"> Wandoo Field OSCP [1] Oil Spill Response Capability Review [2]
	A logistics management plan is in place to inform deployment of resources in a timely manner.	<ul style="list-style-type: none"> A logistics management plan for oil spill response shall identify resources and activation procedures to ensure a timely activation. 	<ul style="list-style-type: none"> Emergency Response Logistics Management Plan [VOG-7000-RH-0008]. 	<ul style="list-style-type: none"> Emergency Response Logistics Management Plan [VOG-7000-RH-0008]
	Contracts are established for equipment and services for the full duration of a response.	<ul style="list-style-type: none"> Contracts must be established for the full duration of a response if: <ul style="list-style-type: none"> services are required to be utilised during the first 20 days of proposed response activities; or the contract is deemed to take longer than 20 days to initiate following a spill. 	<ul style="list-style-type: none"> Signed third party provider contracts. 	<ul style="list-style-type: none"> HSEMS Element 12 – Performance Assessment Manual [3] Oil Spill Response Capability Review [2]
WAN-WNAB-CP-ER-03-01 Response strategy - Monitor and evaluate	Ensure the most effective response strategies are being applied and environmental impact of the spill and response strategies are measured.	<ul style="list-style-type: none"> Monitoring shall be activated from time of spill detection to inform implementation of response strategies. Platform observations commence immediately following the detection of a spill. Visual observations from chartered vessel to be mobilised immediately following the detection of a spill. Aerial observations to be initiated within 2 hours of spill being reported (daylight only). Satellite imagery to be initiated within 2 hours of a spill being reported. Preliminary Oil Spill Trajectory Modelling (OSTM) to be requested within 3 hours of a spill being reported. Satellite tracking buoys to be deployed within 30 minutes of a spill being reported. Tracking buoys data will be monitored and interrogated at least once every 24 hours. OSTM to continue until the termination criteria is met. Operational monitoring shall be available to inform IAP process prior to implementation of strategies that have an environmental impact (e.g. dispersant application). Environmental data to support decision making (IAP) and spill impact assessment shall be available prior to impact. Shoreline Clean-up Assessment Technique (SCAT) teams will complete surveys before clean-up teams' complete assignments so that priority locations are identified, and suitable techniques are used. 	<ul style="list-style-type: none"> Oil Spill Response Capability Review [VOG-7000-RH-0009] contains up-to-date capability assessment of equipment and personnel. Inspections of third-party providers undertaken in accordance with the Wandoo Field OSCP Part 3: Performance Management [WAN-2000-RD-0001]. IAP records. 	<ul style="list-style-type: none"> Oil Spill Response Capability Review [2] HSEMS Element 12 – Performance Assessment Manual [3] Wandoo Field OSCP [1]
WAN-WNAB-CP-ER-03-02 Response Strategy - Chemical dispersant application	Increase the rate of biodegradation to reduce the environmental impact from surface oil and oil stranding on shoreline sensitivities.	<ul style="list-style-type: none"> Dispersant application (aerial and marine) shall be available to be deployed when Wandoo Crude is most amenable to dispersant for the most effective results. Establish an aerial and marine operating base and within 24 hours. Aerial dispersant will be available to be applied within 30 hours. Marine dispersant will be available to be applied within 24 hours. Use of the most effective chemical dispersant to treat Wandoo Crude. Sufficient dispersant available to be applied within the dispersant application zone 	<ul style="list-style-type: none"> Dispersant efficacy testing results on Wandoo Crude. Oil Spill Response Capability Review [VOG-7000-RH-0009] contains up-to-date capability assessment of equipment and personnel. Inspections of third-party providers undertaken in accordance with the Wandoo Field OSCP Part 3: Performance Management [WAN-2000-RD-0001] 	<ul style="list-style-type: none"> Oil Spill Response Capability Review [2] HSEMS Element 12 – Performance Assessment Manual [3]
	Minimise environmental impacts associated with dispersant application.	<ul style="list-style-type: none"> Net environmental benefit analysis undertaken prior to dispersant usage Use of OSCA Register approved dispersants only No dispersant applied within the vicinity of protected marine fauna (based on fauna observations as per OSMP) Dispersant Application Zone in place that excludes the following areas from the spraying of dispersant: <ul style="list-style-type: none"> waters shallower than 20m (lowest astronomical tide); within 4km of State Waters within 10km of Australian Marine Parks (excluding Multiple Use Zones) within 10km of State Protected Areas within 10km of Heritage List Areas within 10km of sensitive receptors (e.g. Glomar Shoals and Rankin Bank) outside the Australian EEZ 	<ul style="list-style-type: none"> IAP records. Accepted Wandoo Field OSCP [WAN-2000-RD-0001]. Oil Spill Response Capability Review [VOG-7000-RH-0009] contains up-to-date capability assessment of equipment and personnel. 	<ul style="list-style-type: none"> Wandoo Field OSCP [1]
WAN-WNAB-CP-ER-03-03 Response strategy - Mechanical dispersant application	Assist natural dispersion of oil into the water column to reduce environmental impact from surface oil.	<ul style="list-style-type: none"> Mechanical dispersion is a secondary strategy that will be used opportunistically based on IAP outcomes. 	<ul style="list-style-type: none"> IAP records. 	<ul style="list-style-type: none"> Wandoo Field OSCP [1]
	Minimise environmental impacts associated with mechanical dispersant activities.	<ul style="list-style-type: none"> Mechanical dispersion shall only be undertaken in water deeper than 20m. 	<ul style="list-style-type: none"> IAP records. 	<ul style="list-style-type: none"> Wandoo Field OSCP [1]

FUNCTIONALITY				
Key Component	Key Requirement	Performance Criteria	Assurance Activity	Reference
WAN-WNAB-CP-ER-03-04 Response strategy - Containment and recovery	Reduce overall volume of surface oil to minimise impacts to environmental sensitivities.	<ul style="list-style-type: none"> Containment and recovery resources will be available to be deployed within 48 hours Equipment available for containment and recovery will be suitable for the hydrocarbon type, and access to equipment will be maintained. Waste storage and transport plan will be developed within 72 hours of the spill event. Temporary waste storage equipment and arrangements will be maintained. 	<ul style="list-style-type: none"> Oil Spill Response Capability Review [VOG-7000-RH-0009] contains up-to-date capability assessment of equipment and personnel. Inspections of third-party providers undertaken in accordance with the Wandoo Field OSCP Part 3: Performance Management [WAN-2000-RD-0001]. IAP records. 	<ul style="list-style-type: none"> Oil Spill Response Capability Review [2] HSEMS Element 12 – Performance Assessment Manual [3] Wandoo Field OSCP [1]
	Minimise environmental impacts associated with improperly deployed equipment.	<ul style="list-style-type: none"> Deployments shall be undertaken by trained incident response personnel. 	<ul style="list-style-type: none"> IAP records. 	<ul style="list-style-type: none"> Wandoo Field OSCP [1]
WAN-WNAB-CP-ER-03-05 Response strategy - Protection and deflection	Minimise environmental impacts to priority near-shore environmental sensitivities by reducing oil contact.	<ul style="list-style-type: none"> Protection and deflection equipment and resources required to be deployed to protection priorities on-site within 48 hours of Category D, E and F spill event. Equipment available for protection and deflection will be suitable for the hydrocarbon type, and access to equipment will be maintained. 	<ul style="list-style-type: none"> Oil Spill Response Capability Review [VOG-7000-RH-0009] contains up-to-date capability assessment of equipment and personnel. Inspections of third-party providers undertaken in accordance with the Wandoo Field OSCP Part 3: Performance Management [WAN-2000-RD-0001]. IAP records. 	<ul style="list-style-type: none"> Oil Spill Response Capability Review [2] HSEMS Element 12 – Performance Assessment Manual [3] Wandoo Field OSCP [1]
	Minimise environmental impacts associated with improperly deployed equipment.	<ul style="list-style-type: none"> Deployments shall be undertaken by trained incident response personnel. Tactical response plans will be available for VOGA priority shorelines 	<ul style="list-style-type: none"> IAP records. Tactical response plans for priority shorelines. 	<ul style="list-style-type: none"> Wandoo Field OSCP [1]
	Minimise impact to fauna from oil spill response activities.	<ul style="list-style-type: none"> Protection and deflection booms shall only be installed after consultation with the Department of Transport and consideration of the sensitive receptors outlined in the environment plan. 	<ul style="list-style-type: none"> IAP records. 	<ul style="list-style-type: none"> Wandoo Field OSCP [1]
WAN-WNAB-CP-ER-03-06 Response strategy - Shoreline clean-up	Remove stranded hydrocarbons from shorelines without causing greater environmental impact than leaving the hydrocarbons in-situ.	<ul style="list-style-type: none"> Equipment for shoreline clean-up tasks that are suitable for environment and hydrocarbon type are available. Shoreline clean-up resources can be deployed to protection priorities within 72 hours. Shoreline clean-up resources will be available within the first three days, consisting of three teams made up of one shoreline team leader and ten shoreline workers. Shoreline teams will be informed of how to minimise damage to flora and avoid encounters with fauna. SCAT teams will complete surveys before clean-up team complete assignments so that priority locations are worked on and suitable techniques are used. Shoreline clean-up will implement a three-stage methodology: <ul style="list-style-type: none"> Emergency phase – collection of oil floating close to the shore and pooled bulk oil removal. Project phase – removal of stranded oil and oiled shoreline material that cannot be cleaned in-situ. Polishing phase – final clean-up of light oil contamination and removal of oil stains, where the incident Net Environmental Benefit Analysis demonstrates this is necessary. Waste storage and transport plan will be developed within 72 hours of the spill event. Temporary waste storage equipment and arrangements will be maintained. 	<ul style="list-style-type: none"> Oil Spill Response Capability Review [VOG-7000-RH-0009] contains up-to-date capability assessment of equipment and personnel. Inspections of third-party providers undertaken in accordance with OSCP Part 3: Performance Management [WAN-2000-RD-0001]. IAP records. 	<ul style="list-style-type: none"> Oil Spill Response Capability Review [2] HSEMS Element 12 – Performance Assessment Manual [3] Wandoo Field OSCP [1]
	Minimise impact to key shoreline habitats associated with shoreline clean-up activities.	<ul style="list-style-type: none"> A shoreline assessment form shall be developed and implemented in consultation with appropriate stakeholders and shall detail controls to minimise environmental impacts. Sorbents shall not be used for shoreline clean-up on high energy shorelines. Mechanical removal and high-pressure flushing shall not be undertaken in mangrove areas. Water from high pressure flushing shall not be directed in between rocks and onto sediment. Steam cleaning shall not be undertaken on surfaces that support living plants or animals. Tactical response plans will be available for VOGA priority shorelines outlining potential clean-up and waste collection methodologies 	<ul style="list-style-type: none"> Completed shoreline assessment form. IAP records. 	<ul style="list-style-type: none"> Wandoo Field OSCP [1]
WAN-WNAB-CP-ER-03-07 Response strategy - Oiled wildlife response	Minimise and mitigate the number of wildlife oiled following a spill.	<ul style="list-style-type: none"> Resources for oiled wildlife response activities have been planned for a Level 6 Oiled Wildlife Response. First strike response kits are activated within 24 hours. An Oiled Wildlife Advisor and Wildlife Division Coordinator are activated and assigned to the ICT once the Western Australian Oiled Wildlife Response Plan is activated. Information contained in POWRP and NEBA is ground truthed. IAP wildlife sub-plan developed within 48 hours. Wildlife rescue and staging site establishment is activated within 72 hours. 	<ul style="list-style-type: none"> Oil Spill Response Capability Review [VOG-7000-RH-0009] contains up-to-date capability assessment of equipment and personnel. Inspections of third-party providers undertaken in accordance with OSCP Part 3: Performance Management [WAN-2000-RD-0001]. IAP records. 	<ul style="list-style-type: none"> Oil Spill Response Capability Review [2] HSEMS Element 12 – Performance Assessment Manual [3] Wandoo Field OSCP [1]
	Minimise potential impacts on fauna caused by oiled wildlife response activities.	<ul style="list-style-type: none"> Induction and training shall cover any special handling requirements to minimise further detrimental impacts to flora and fauna. Wildlife strategy including hazing, if required, shall be developed in consultation with the Department of Transport. 	<ul style="list-style-type: none"> Oiled wildlife response induction material. IAP records. 	<ul style="list-style-type: none"> Wandoo Field OSCP [1]

EFFECTIVENESS				
Key Component	Key Requirement	Performance Criteria	Assurance Activity	Reference
WAN-WNAB-CP-ER-01-04 Arrangements are accessible	Current oil spill response arrangements are accessible to all personnel in the event of an oil spill	<ul style="list-style-type: none"> Oil spill response documentation is up to date, maintained and readily available within VOGA Information Systems. Copies of the Wandoo Field OSCP are available. 	<ul style="list-style-type: none"> HSEMS audits of Element 8 are conducted in accordance with the HSEMS Element 12 – Performance Assessment Manual [VOG-1100-YG-1201]. 	<ul style="list-style-type: none"> HSEMS Element 12 – Performance Assessment Manual [3]
WAN-WNAB-CP-ER-01-05 Arrangements are understood	Oil spill response personnel understand and competently perform their response roles	<ul style="list-style-type: none"> Drills and exercises shall be carried out to review the effectiveness of the plan. Oil spill response personnel are competent in their required emergency response roles. All personnel with roles within the Corporate Command Team, ICT and On-Site Command Team have training appropriate to their roles. All training courses and participation in drills and exercises are recorded in training records. 	<ul style="list-style-type: none"> Exercises conducted in accordance with VOGA Emergency Response Schedule [VOG-1100-YH-0001]. HSEMS audits of Element 8 are conducted in accordance with the HSEMS Element 12 – Performance Assessment Manual [VOG-1100-YG-1201]. Inspections of third-party providers in accordance with Wandoo Field OSCP Part 3: Performance Management [WAN-2000-RD-0001]. 	<ul style="list-style-type: none"> Emergency Response Schedule [4] Platform Operations Manual – Emergency Drill Guidelines [5] HSEMS Element 12 – Performance Assessment Manual [3] Wandoo Field OSCP [1]

INTERDEPENDENCY		
Control Measure	Input / Output	Explanation
WAN-WNAB-CP-ALL-01 Training and Competency	Input	Personnel are competent to perform their emergency response roles
WAN-WNAB-CP-ER-01 Emergency Preparedness, Management and Response	Input	To define the wider emergency response requirements
WAN-WNAB-CE-ES-02 Emergency Communications	Input	To permit relaying of emergency instructions and coordination of emergency response actions

DOCUMENT REFERENCES		
Ref	Document No.	Document Title
[1]	WAN-2000-RD-0001	Wandoo Field OSCP
[2]	VOG-7000-RH-0009	Oil Spill Response Capability Review
[3]	VOG-1100-YG-1201	HSEMS Element 12 – Performance Assessment Manual
[4]	VOG-1100-YH-0001	Emergency Response Schedule
[5]	VOG-7000-MN-0001 - WNB-000-001	Platform Operations Manual – Emergency Drill Guidelines

DOCUMENT CONTROL HISTORY			
Revision	Description	Comments	Date
A	Issued for review	Initial issue	12 January 2016
0	Issued for use	Issued for use	8 February 2016
1	Issued for use	Issued for use	21 July 2017
2	Issued for use	Issued for use	4 December 2020
3	Issued for use	Issued for use	21 April 2021

APPROVALS		
Role	Signature	Date
HSE Manager	ORIGINAL SIGNED	ORIGINAL SIGNED
Environmental Advisor	ORIGINAL SIGNED	ORIGINAL SIGNED
Managing Director	ORIGINAL SIGNED	ORIGINAL SIGNED

Appendix 6: Protected Matters Searches

**Operational Area and Mixing Zone
EPBC Protected Matters Report
(December 2020)**



EPBC Act Protected Matters Report

This report provides general guidance on matters of national environmental significance and other matters protected by the EPBC Act in the area you have selected.

Information on the coverage of this report and qualifications on data supporting this report are contained in the caveat at the end of the report.

Information is available about [Environment Assessments](#) and the EPBC Act including significance guidelines, forms and application process details.

Report created: 03/12/20 19:46:54

[Summary](#)

[Details](#)

[Matters of NES](#)

[Other Matters Protected by the EPBC Act](#)

[Extra Information](#)

[Caveat](#)

[Acknowledgements](#)

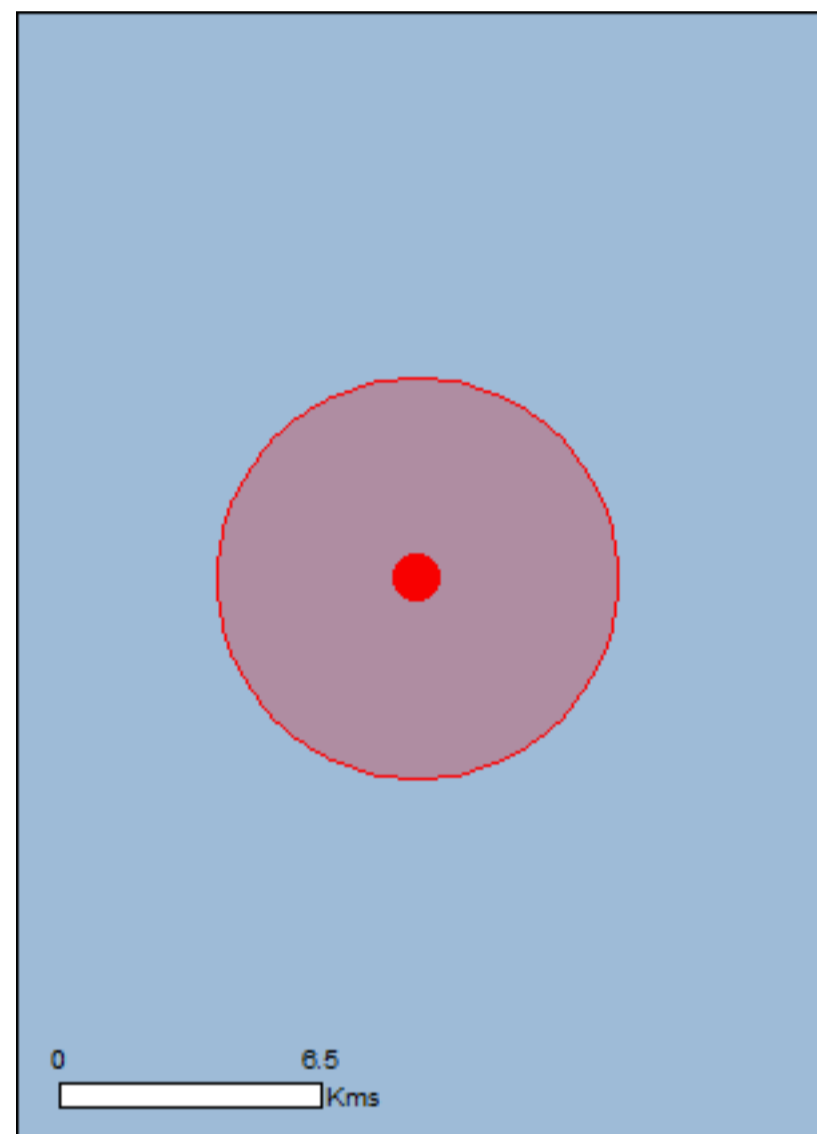

This map may contain data which are
©Commonwealth of Australia
(Geoscience Australia), ©PSMA 2015

[Coordinates](#)

Buffer: 5.0Km

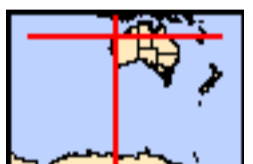

Summary

Matters of National Environmental Significance

This part of the report summarises the matters of national environmental significance that may occur in, or may relate to, the area you nominated. Further information is available in the detail part of the report, which can be accessed by scrolling or following the links below. If you are proposing to undertake an activity that may have a significant impact on one or more matters of national environmental significance then you should consider the [Administrative Guidelines on Significance](#).

World Heritage Properties:	None
National Heritage Places:	None
Wetlands of International Importance:	None
Great Barrier Reef Marine Park:	None
Commonwealth Marine Area:	1
Listed Threatened Ecological Communities:	None
Listed Threatened Species:	19
Listed Migratory Species:	34

Other Matters Protected by the EPBC Act

This part of the report summarises other matters protected under the Act that may relate to the area you nominated. Approval may be required for a proposed activity that significantly affects the environment on Commonwealth land, when the action is outside the Commonwealth land, or the environment anywhere when the action is taken on Commonwealth land. Approval may also be required for the Commonwealth or Commonwealth agencies proposing to take an action that is likely to have a significant impact on the environment anywhere.

The EPBC Act protects the environment on Commonwealth land, the environment from the actions taken on Commonwealth land, and the environment from actions taken by Commonwealth agencies. As heritage values of a place are part of the 'environment', these aspects of the EPBC Act protect the Commonwealth Heritage values of a Commonwealth Heritage place. Information on the new heritage laws can be found at <http://www.environment.gov.au/heritage>

A [permit](#) may be required for activities in or on a Commonwealth area that may affect a member of a listed threatened species or ecological community, a member of a listed migratory species, whales and other cetaceans, or a member of a listed marine species.

Commonwealth Land:	None
Commonwealth Heritage Places:	None
Listed Marine Species:	62
Whales and Other Cetaceans:	15
Critical Habitats:	None
Commonwealth Reserves Terrestrial:	None
Australian Marine Parks:	None

Extra Information

This part of the report provides information that may also be relevant to the area you have nominated.

State and Territory Reserves:	None
Regional Forest Agreements:	None
Invasive Species:	None
Nationally Important Wetlands:	None
Key Ecological Features (Marine)	None

Details

Matters of National Environmental Significance

Commonwealth Marine Area

[\[Resource Information \]](#)

Approval is required for a proposed activity that is located within the Commonwealth Marine Area which has, will have, or is likely to have a significant impact on the environment. Approval may be required for a proposed action taken outside the Commonwealth Marine Area but which has, may have or is likely to have a significant impact on the environment in the Commonwealth Marine Area. Generally the Commonwealth Marine Area stretches from three nautical miles to two hundred nautical miles from the coast.

Name

EEZ and Territorial Sea

Marine Regions

[\[Resource Information \]](#)

If you are planning to undertake action in an area in or close to the Commonwealth Marine Area, and a marine bioregional plan has been prepared for the Commonwealth Marine Area in that area, the marine bioregional plan may inform your decision as to whether to refer your proposed action under the EPBC Act.

Name

[North-west](#)

Listed Threatened Species

[\[Resource Information \]](#)

Name	Status	Type of Presence
Birds		
Calidris canutus Red Knot, Knot [855]	Endangered	Species or species habitat may occur within area
Calidris ferruginea Curlew Sandpiper [856]	Critically Endangered	Species or species habitat may occur within area
Macronectes giganteus Southern Giant-Petrel, Southern Giant Petrel [1060]	Endangered	Species or species habitat may occur within area
Numenius madagascariensis Eastern Curlew, Far Eastern Curlew [847]	Critically Endangered	Species or species habitat may occur within area
Sternula nereis nereis Australian Fairy Tern [82950]	Vulnerable	Foraging, feeding or related behaviour likely to occur within area
Mammals		
Balaenoptera borealis Sei Whale [34]	Vulnerable	Species or species habitat may occur within area
Balaenoptera musculus Blue Whale [36]	Endangered	Species or species habitat likely to occur within area
Balaenoptera physalus Fin Whale [37]	Vulnerable	Species or species habitat may occur within area
Megaptera novaeangliae Humpback Whale [38]	Vulnerable	Breeding known to occur

Name	Status	Type of Presence within area
Reptiles		
Caretta caretta Loggerhead Turtle [1763]	Endangered	Species or species habitat known to occur within area
Chelonia mydas Green Turtle [1765]	Vulnerable	Species or species habitat known to occur within area
Dermochelys coriacea Leatherback Turtle, Leathery Turtle, Luth [1768]	Endangered	Species or species habitat likely to occur within area
Eretmochelys imbricata Hawksbill Turtle [1766]	Vulnerable	Species or species habitat known to occur within area
Natator depressus Flatback Turtle [59257]	Vulnerable	Congregation or aggregation known to occur within area
Sharks		
Carcharias taurus (west coast population) Grey Nurse Shark (west coast population) [68752]	Vulnerable	Species or species habitat likely to occur within area
Carcharodon carcharias White Shark, Great White Shark [64470]	Vulnerable	Species or species habitat may occur within area
Pristis clavata Dwarf Sawfish, Queensland Sawfish [68447]	Vulnerable	Species or species habitat known to occur within area
Pristis zijsron Green Sawfish, Dindagubba, Narrowsnout Sawfish [68442]	Vulnerable	Species or species habitat known to occur within area
Rhincodon typus Whale Shark [66680]	Vulnerable	Foraging, feeding or related behaviour known to occur within area
Listed Migratory Species		[Resource Information]
* Species is listed under a different scientific name on the EPBC Act - Threatened Species list.		
Name	Threatened	Type of Presence
Migratory Marine Birds		
Anous stolidus Common Noddy [825]		Species or species habitat may occur within area
Calonectris leucomelas Streaked Shearwater [1077]		Species or species habitat likely to occur within area
Fregata ariel Lesser Frigatebird, Least Frigatebird [1012]		Species or species habitat likely to occur within area
Macronectes giganteus Southern Giant-Petrel, Southern Giant Petrel [1060]	Endangered	Species or species habitat may occur within area
Migratory Marine Species		
Anoxypristis cuspidata Narrow Sawfish, Knifetooth Sawfish [68448]		Species or species habitat may occur within area
Balaenoptera borealis Sei Whale [34]	Vulnerable	Species or species habitat may occur within

Name	Threatened	Type of Presence area
Balaenoptera edeni Bryde's Whale [35]		Species or species habitat may occur within area
Balaenoptera musculus Blue Whale [36]	Endangered	Species or species habitat likely to occur within area
Balaenoptera physalus Fin Whale [37]	Vulnerable	Species or species habitat may occur within area
Carcharhinus longimanus Oceanic Whitetip Shark [84108]		Species or species habitat likely to occur within area
Carcharodon carcharias White Shark, Great White Shark [64470]	Vulnerable	Species or species habitat may occur within area
Caretta caretta Loggerhead Turtle [1763]	Endangered	Species or species habitat known to occur within area
Chelonia mydas Green Turtle [1765]	Vulnerable	Species or species habitat known to occur within area
Dermochelys coriacea Leatherback Turtle, Leathery Turtle, Luth [1768]	Endangered	Species or species habitat likely to occur within area
Eretmochelys imbricata Hawksbill Turtle [1766]	Vulnerable	Species or species habitat known to occur within area
Isurus oxyrinchus Shortfin Mako, Mako Shark [79073]		Species or species habitat likely to occur within area
Isurus paucus Longfin Mako [82947]		Species or species habitat likely to occur within area
Manta alfredi Reef Manta Ray, Coastal Manta Ray, Inshore Manta Ray, Prince Alfred's Ray, Resident Manta Ray [84994]		Species or species habitat known to occur within area
Manta birostris Giant Manta Ray, Chevron Manta Ray, Pacific Manta Ray, Pelagic Manta Ray, Oceanic Manta Ray [84995]		Species or species habitat likely to occur within area
Megaptera novaeangliae Humpback Whale [38]	Vulnerable	Breeding known to occur within area
Natator depressus Flatback Turtle [59257]	Vulnerable	Congregation or aggregation known to occur within area
Orcinus orca Killer Whale, Orca [46]		Species or species habitat may occur within area
Pristis clavata Dwarf Sawfish, Queensland Sawfish [68447]	Vulnerable	Species or species habitat known to occur within area
Pristis zijsron Green Sawfish, Dindagubba, Narrowsnout Sawfish [68442]	Vulnerable	Species or species habitat known to occur within area

Name	Threatened	Type of Presence
Rhincodon typus Whale Shark [66680]	Vulnerable	Foraging, feeding or related behaviour known to occur within area
Sousa chinensis Indo-Pacific Humpback Dolphin [50]		Species or species habitat may occur within area
Tursiops aduncus (Arafura/Timor Sea populations) Spotted Bottlenose Dolphin (Arafura/Timor Sea populations) [78900]		Species or species habitat likely to occur within area
Migratory Wetlands Species		
Actitis hypoleucos Common Sandpiper [59309]		Species or species habitat may occur within area
Calidris acuminata Sharp-tailed Sandpiper [874]		Species or species habitat may occur within area
Calidris canutus Red Knot, Knot [855]	Endangered	Species or species habitat may occur within area
Calidris ferruginea Curlew Sandpiper [856]	Critically Endangered	Species or species habitat may occur within area
Calidris melanotos Pectoral Sandpiper [858]		Species or species habitat may occur within area
Numenius madagascariensis Eastern Curlew, Far Eastern Curlew [847]	Critically Endangered	Species or species habitat may occur within area
Pandion haliaetus Osprey [952]		Species or species habitat may occur within area

Other Matters Protected by the EPBC Act

Listed Marine Species	[Resource Information]	
* Species is listed under a different scientific name on the EPBC Act - Threatened Species list.		
Name	Threatened	Type of Presence
Birds		
Actitis hypoleucos Common Sandpiper [59309]		Species or species habitat may occur within area
Anous stolidus Common Noddy [825]		Species or species habitat may occur within area
Calidris acuminata Sharp-tailed Sandpiper [874]		Species or species habitat may occur within area
Calidris canutus Red Knot, Knot [855]	Endangered	Species or species habitat may occur within area
Calidris ferruginea Curlew Sandpiper [856]	Critically Endangered	Species or species habitat may occur within area

Name	Threatened	Type of Presence
Calidris melanotos Pectoral Sandpiper [858]		Species or species habitat may occur within area
Calonectris leucomelas Streaked Shearwater [1077]		Species or species habitat likely to occur within area
Fregata ariel Lesser Frigatebird, Least Frigatebird [1012]		Species or species habitat likely to occur within area
Macronectes giganteus Southern Giant-Petrel, Southern Giant Petrel [1060]	Endangered	Species or species habitat may occur within area
Numenius madagascariensis Eastern Curlew, Far Eastern Curlew [847]	Critically Endangered	Species or species habitat may occur within area
Pandion haliaetus Osprey [952]		Species or species habitat may occur within area
Fish		
Acentronura larsonae Helen's Pygmy Pipehorse [66186]		Species or species habitat may occur within area
Bulbonaricus brauni Braun's Pughead Pipefish, Pug-headed Pipefish [66189]		Species or species habitat may occur within area
Campichthys tricarinatus Three-keel Pipefish [66192]		Species or species habitat may occur within area
Choeroichthys brachysoma Pacific Short-bodied Pipefish, Short-bodied Pipefish [66194]		Species or species habitat may occur within area
Choeroichthys latispinosus Muiron Island Pipefish [66196]		Species or species habitat may occur within area
Choeroichthys suillus Pig-snouted Pipefish [66198]		Species or species habitat may occur within area
Doryrhamphus dactyliophorus Banded Pipefish, Ringed Pipefish [66210]		Species or species habitat may occur within area
Doryrhamphus janssi Cleaner Pipefish, Janss' Pipefish [66212]		Species or species habitat may occur within area
Doryrhamphus multiannulatus Many-banded Pipefish [66717]		Species or species habitat may occur within area
Doryrhamphus negrosensis Flagtail Pipefish, Masthead Island Pipefish [66213]		Species or species habitat may occur within area
Festucalex scalaris Ladder Pipefish [66216]		Species or species habitat may occur within area
Filicampus tigris Tiger Pipefish [66217]		Species or species habitat may occur within area

Name	Threatened	Type of Presence
Halicampus brocki Brock's Pipefish [66219]		Species or species habitat may occur within area
Halicampus grayi Mud Pipefish, Gray's Pipefish [66221]		Species or species habitat may occur within area
Halicampus nitidus Glittering Pipefish [66224]		Species or species habitat may occur within area
Halicampus spirostris Spiny-snout Pipefish [66225]		Species or species habitat may occur within area
Haliichthys taeniophorus Ribboned Pipehorse, Ribboned Seadragon [66226]		Species or species habitat may occur within area
Hippichthys penicillus Beady Pipefish, Steep-nosed Pipefish [66231]		Species or species habitat may occur within area
Hippocampus angustus Western Spiny Seahorse, Narrow-bellied Seahorse [66234]		Species or species habitat may occur within area
Hippocampus histrix Spiny Seahorse, Thorny Seahorse [66236]		Species or species habitat may occur within area
Hippocampus kuda Spotted Seahorse, Yellow Seahorse [66237]		Species or species habitat may occur within area
Hippocampus planifrons Flat-face Seahorse [66238]		Species or species habitat may occur within area
Hippocampus trimaculatus Three-spot Seahorse, Low-crowned Seahorse, Flat-faced Seahorse [66720]		Species or species habitat may occur within area
Micrognathus micronotopterus Tidepool Pipefish [66255]		Species or species habitat may occur within area
Phoxocampus belcheri Black Rock Pipefish [66719]		Species or species habitat may occur within area
Solegnathus hardwickii Pallid Pipehorse, Hardwick's Pipehorse [66272]		Species or species habitat may occur within area
Solegnathus lettiensis Gunther's Pipehorse, Indonesian Pipefish [66273]		Species or species habitat may occur within area
Solenostomus cyanopterus Robust Ghostpipefish, Blue-finned Ghost Pipefish, [66183]		Species or species habitat may occur within area
Syngnathoides biaculeatus Double-end Pipehorse, Double-ended Pipehorse, Alligator Pipefish [66279]		Species or species habitat may occur within area
Trachyrhamphus bicoarctatus Bentstick Pipefish, Bend Stick Pipefish, Short-tailed Pipefish [66280]		Species or species habitat may occur within area

Name	Threatened	Type of Presence
Trachyrhamphus longirostris Straightstick Pipefish, Long-nosed Pipefish, Straight Stick Pipefish [66281]		Species or species habitat may occur within area
Reptiles		
Acalyptophis peronii Horned Seasnake [1114]		Species or species habitat may occur within area
Aipysurus duboisii Dubois' Seasnake [1116]		Species or species habitat may occur within area
Aipysurus eydouxii Spine-tailed Seasnake [1117]		Species or species habitat may occur within area
Aipysurus laevis Olive Seasnake [1120]		Species or species habitat may occur within area
Aipysurus tenuis Brown-lined Seasnake [1121]		Species or species habitat may occur within area
Astrotia stokesii Stokes' Seasnake [1122]		Species or species habitat may occur within area
Caretta caretta Loggerhead Turtle [1763]	Endangered	Species or species habitat known to occur within area
Chelonia mydas Green Turtle [1765]	Vulnerable	Species or species habitat known to occur within area
Dermochelys coriacea Leatherback Turtle, Leathery Turtle, Luth [1768]	Endangered	Species or species habitat likely to occur within area
Disteira kingii Spectacled Seasnake [1123]		Species or species habitat may occur within area
Disteira major Olive-headed Seasnake [1124]		Species or species habitat may occur within area
Ephalophis greyi North-western Mangrove Seasnake [1127]		Species or species habitat may occur within area
Eretmochelys imbricata Hawksbill Turtle [1766]	Vulnerable	Species or species habitat known to occur within area
Hydrelaps darwiniensis Black-ringed Seasnake [1100]		Species or species habitat may occur within area
Hydrophis czeblukovi Fine-spined Seasnake [59233]		Species or species habitat may occur within area
Hydrophis elegans Elegant Seasnake [1104]		Species or species habitat may occur within area
Hydrophis mcdowellii null [25926]		Species or species habitat may occur within area

Name	Threatened	Type of Presence
Hydrophis ornatus Spotted Seasnake, Ornate Reef Seasnake [1111]		Species or species habitat may occur within area
Natator depressus Flatback Turtle [59257]	Vulnerable	Congregation or aggregation known to occur within area
Pelamis platurus Yellow-bellied Seasnake [1091]		Species or species habitat may occur within area

Whales and other Cetaceans [Resource Information]

Name	Status	Type of Presence
Mammals		
Balaenoptera acutorostrata Minke Whale [33]		Species or species habitat may occur within area
Balaenoptera borealis Sei Whale [34]	Vulnerable	Species or species habitat may occur within area
Balaenoptera edeni Bryde's Whale [35]		Species or species habitat may occur within area
Balaenoptera musculus Blue Whale [36]	Endangered	Species or species habitat likely to occur within area
Balaenoptera physalus Fin Whale [37]	Vulnerable	Species or species habitat may occur within area
Delphinus delphis Common Dolphin, Short-beaked Common Dolphin [60]		Species or species habitat may occur within area
Grampus griseus Risso's Dolphin, Grampus [64]		Species or species habitat may occur within area
Megaptera novaeangliae Humpback Whale [38]	Vulnerable	Breeding known to occur within area
Orcinus orca Killer Whale, Orca [46]		Species or species habitat may occur within area
Pseudorca crassidens False Killer Whale [48]		Species or species habitat likely to occur within area
Sousa chinensis Indo-Pacific Humpback Dolphin [50]		Species or species habitat may occur within area
Stenella attenuata Spotted Dolphin, Pantropical Spotted Dolphin [51]		Species or species habitat may occur within area
Tursiops aduncus Indian Ocean Bottlenose Dolphin, Spotted Bottlenose Dolphin [68418]		Species or species habitat may occur within area
Tursiops aduncus (Arafura/Timor Sea populations) Spotted Bottlenose Dolphin (Arafura/Timor Sea populations) [78900]		Species or species habitat likely to occur within area
Tursiops truncatus s. str. Bottlenose Dolphin [68417]		Species or species

Name	Status	Type of Presence
------	--------	------------------

habitat may occur within area

Extra Information

Caveat

The information presented in this report has been provided by a range of data sources as acknowledged at the end of the report.

This report is designed to assist in identifying the locations of places which may be relevant in determining obligations under the Environment Protection and Biodiversity Conservation Act 1999. It holds mapped locations of World and National Heritage properties, Wetlands of International and National Importance, Commonwealth and State/Territory reserves, listed threatened, migratory and marine species and listed threatened ecological communities. Mapping of Commonwealth land is not complete at this stage. Maps have been collated from a range of sources at various resolutions.

Not all species listed under the EPBC Act have been mapped (see below) and therefore a report is a general guide only. Where available data supports mapping, the type of presence that can be determined from the data is indicated in general terms. People using this information in making a referral may need to consider the qualifications below and may need to seek and consider other information sources.

For threatened ecological communities where the distribution is well known, maps are derived from recovery plans, State vegetation maps, remote sensing imagery and other sources. Where threatened ecological community distributions are less well known, existing vegetation maps and point location data are used to produce indicative distribution maps.

Threatened, migratory and marine species distributions have been derived through a variety of methods. Where distributions are well known and if time permits, maps are derived using either thematic spatial data (i.e. vegetation, soils, geology, elevation, aspect, terrain, etc) together with point locations and described habitat; or environmental modelling (MAXENT or BIOCLIM habitat modelling) using point locations and environmental data layers.

Where very little information is available for species or large number of maps are required in a short time-frame, maps are derived either from 0.04 or 0.02 decimal degree cells; by an automated process using polygon capture techniques (static two kilometre grid cells, alpha-hull and convex hull); or captured manually or by using topographic features (national park boundaries, islands, etc). In the early stages of the distribution mapping process (1999-early 2000s) distributions were defined by degree blocks, 100K or 250K map sheets to rapidly create distribution maps. More reliable distribution mapping methods are used to update these distributions as time permits.

Only selected species covered by the following provisions of the EPBC Act have been mapped:

- migratory and
- marine

The following species and ecological communities have not been mapped and do not appear in reports produced from this database:

- threatened species listed as extinct or considered as vagrants
- some species and ecological communities that have only recently been listed
- some terrestrial species that overfly the Commonwealth marine area
- migratory species that are very widespread, vagrant, or only occur in small numbers

The following groups have been mapped, but may not cover the complete distribution of the species:

- non-threatened seabirds which have only been mapped for recorded breeding sites
- seals which have only been mapped for breeding sites near the Australian continent

Such breeding sites may be important for the protection of the Commonwealth Marine environment.

Coordinates

-20.12861 116.43444

Acknowledgements

This database has been compiled from a range of data sources. The department acknowledges the following custodians who have contributed valuable data and advice:

- [-Office of Environment and Heritage, New South Wales](#)
- [-Department of Environment and Primary Industries, Victoria](#)
- [-Department of Primary Industries, Parks, Water and Environment, Tasmania](#)
- [-Department of Environment, Water and Natural Resources, South Australia](#)
- [-Department of Land and Resource Management, Northern Territory](#)
- [-Department of Environmental and Heritage Protection, Queensland](#)
- [-Department of Parks and Wildlife, Western Australia](#)
- [-Environment and Planning Directorate, ACT](#)
- [-Birdlife Australia](#)
- [-Australian Bird and Bat Banding Scheme](#)
- [-Australian National Wildlife Collection](#)
- [-Natural history museums of Australia](#)
- [-Museum Victoria](#)
- [-Australian Museum](#)
- [-South Australian Museum](#)
- [-Queensland Museum](#)
- [-Online Zoological Collections of Australian Museums](#)
- [-Queensland Herbarium](#)
- [-National Herbarium of NSW](#)
- [-Royal Botanic Gardens and National Herbarium of Victoria](#)
- [-Tasmanian Herbarium](#)
- [-State Herbarium of South Australia](#)
- [-Northern Territory Herbarium](#)
- [-Western Australian Herbarium](#)
- [-Australian National Herbarium, Canberra](#)
- [-University of New England](#)
- [-Ocean Biogeographic Information System](#)
- [-Australian Government, Department of Defence Forestry Corporation, NSW](#)
- [-Geoscience Australia](#)
- [-CSIRO](#)
- [-Australian Tropical Herbarium, Cairns](#)
- [-eBird Australia](#)
- [-Australian Government – Australian Antarctic Data Centre](#)
- [-Museum and Art Gallery of the Northern Territory](#)
- [-Australian Government National Environmental Science Program](#)
- [-Australian Institute of Marine Science](#)
- [-Reef Life Survey Australia](#)
- [-American Museum of Natural History](#)
- [-Queen Victoria Museum and Art Gallery, Inveresk, Tasmania](#)
- [-Tasmanian Museum and Art Gallery, Hobart, Tasmania](#)
- [-Other groups and individuals](#)

The Department is extremely grateful to the many organisations and individuals who provided expert advice and information on numerous draft distributions.

Please feel free to provide feedback via the [Contact Us](#) page.

© Commonwealth of Australia

Department of Agriculture Water and the Environment

GPO Box 858

Canberra City ACT 2601 Australia

+61 2 6274 1111

Hydrocarbon Area
EPBC Protected Matters Report
(December 2020)



EPBC Act Protected Matters Report

This report provides general guidance on matters of national environmental significance and other matters protected by the EPBC Act in the area you have selected.

Information on the coverage of this report and qualifications on data supporting this report are contained in the caveat at the end of the report.

Information is available about [Environment Assessments](#) and the EPBC Act including significance guidelines, forms and application process details.

Report created: 01/12/20 19:05:13

[Summary](#)

[Details](#)

[Matters of NES](#)

[Other Matters Protected by the EPBC Act](#)

[Extra Information](#)

[Caveat](#)

[Acknowledgements](#)



This map may contain data which are
©Commonwealth of Australia
(Geoscience Australia), ©PSMA 2015

[Coordinates](#)

[Buffer: 1.0Km](#)

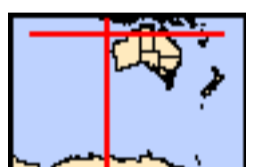

Summary

Matters of National Environmental Significance

This part of the report summarises the matters of national environmental significance that may occur in, or may relate to, the area you nominated. Further information is available in the detail part of the report, which can be accessed by scrolling or following the links below. If you are proposing to undertake an activity that may have a significant impact on one or more matters of national environmental significance then you should consider the [Administrative Guidelines on Significance](#).

World Heritage Properties:	2
National Heritage Places:	5
Wetlands of International Importance:	5
Great Barrier Reef Marine Park:	None
Commonwealth Marine Area:	2
Listed Threatened Ecological Communities:	1
Listed Threatened Species:	104
Listed Migratory Species:	101

Other Matters Protected by the EPBC Act

This part of the report summarises other matters protected under the Act that may relate to the area you nominated. Approval may be required for a proposed activity that significantly affects the environment on Commonwealth land, when the action is outside the Commonwealth land, or the environment anywhere when the action is taken on Commonwealth land. Approval may also be required for the Commonwealth or Commonwealth agencies proposing to take an action that is likely to have a significant impact on the environment anywhere.

The EPBC Act protects the environment on Commonwealth land, the environment from the actions taken on Commonwealth land, and the environment from actions taken by Commonwealth agencies. As heritage values of a place are part of the 'environment', these aspects of the EPBC Act protect the Commonwealth Heritage values of a Commonwealth Heritage place. Information on the new heritage laws can be found at <http://www.environment.gov.au/heritage>

A [permit](#) may be required for activities in or on a Commonwealth area that may affect a member of a listed threatened species or ecological community, a member of a listed migratory species, whales and other cetaceans, or a member of a listed marine species.

Commonwealth Land:	8
Commonwealth Heritage Places:	18
Listed Marine Species:	192
Whales and Other Cetaceans:	34
Critical Habitats:	None
Commonwealth Reserves Terrestrial:	1
Australian Marine Parks:	27

Extra Information

This part of the report provides information that may also be relevant to the area you have nominated.

State and Territory Reserves:	68
Regional Forest Agreements:	None
Invasive Species:	35
Nationally Important Wetlands:	13
Key Ecological Features (Marine)	16

Details

Matters of National Environmental Significance

World Heritage Properties		[Resource Information]
Name	State	Status
Shark Bay, Western Australia	WA	Declared property
The Ningaloo Coast	WA	Declared property

National Heritage Properties		[Resource Information]
Name	State	Status
Natural		
Shark Bay, Western Australia	WA	Listed place
The Ningaloo Coast	WA	Listed place
The West Kimberley	WA	Listed place
Indigenous		
Dampier Archipelago (including Burrup Peninsula)	WA	Listed place
Historic		
HMAS Sydney II and HSK Kormoran Shipwreck Sites	EXT	Listed place

Wetlands of International Importance (Ramsar)		[Resource Information]
Name	Proximity	
Ashmore reef national nature reserve	Within Ramsar site	
Eighty-mile beach	Within Ramsar site	
Hosnies spring	Within Ramsar site	
Roebuck bay	Within Ramsar site	
The dales	Within Ramsar site	

Commonwealth Marine Area	[Resource Information]
Approval is required for a proposed activity that is located within the Commonwealth Marine Area which has, will have, or is likely to have a significant impact on the environment. Approval may be required for a proposed action taken outside the Commonwealth Marine Area but which has, may have or is likely to have a significant impact on the environment in the Commonwealth Marine Area. Generally the Commonwealth Marine Area stretches from three nautical miles to two hundred nautical miles from the coast.	

Name
EEZ and Territorial Sea
Extended Continental Shelf

Marine Regions	[Resource Information]
If you are planning to undertake action in an area in or close to the Commonwealth Marine Area, and a marine bioregional plan has been prepared for the Commonwealth Marine Area in that area, the marine bioregional plan may inform your decision as to whether to refer your proposed action under the EPBC Act.	

Name
North-west
South-west

Listed Threatened Ecological Communities	[Resource Information]
For threatened ecological communities where the distribution is well known, maps are derived from recovery plans, State vegetation maps, remote sensing imagery and other sources. Where threatened ecological community distributions are less well known, existing vegetation maps and point location data are used to produce indicative distribution maps.	

Name	Status	Type of Presence
Monsoon vine thickets on the coastal sand dunes of Dampier Peninsula	Endangered	Community likely to occur within area

Listed Threatened Species	[Resource Information]	
Name	Status	Type of Presence
Birds		
Accipiter hiogaster natalis	Endangered	Species or species habitat known to occur within area
Christmas Island Goshawk [82408]		

Name	Status	Type of Presence
Anous tenuirostris melanops Australian Lesser Noddy [26000]	Vulnerable	Breeding known to occur within area
Calidris canutus Red Knot, Knot [855]	Endangered	Species or species habitat known to occur within area
Calidris ferruginea Curlew Sandpiper [856]	Critically Endangered	Species or species habitat known to occur within area
Calidris tenuirostris Great Knot [862]	Critically Endangered	Roosting known to occur within area
Chalcophaps indica natalis Christmas Island Emerald Dove, Emerald Dove (Christmas Island) [67030]	Endangered	Species or species habitat known to occur within area
Charadrius leschenaultii Greater Sand Plover, Large Sand Plover [877]	Vulnerable	Roosting known to occur within area
Charadrius mongolus Lesser Sand Plover, Mongolian Plover [879]	Endangered	Roosting known to occur within area
Diomedea amsterdamensis Amsterdam Albatross [64405]	Endangered	Species or species habitat likely to occur within area
Diomedea epomophora Southern Royal Albatross [89221]	Vulnerable	Species or species habitat may occur within area
Diomedea exulans Wandering Albatross [89223]	Vulnerable	Species or species habitat may occur within area
Erythrotriorchis radiatus Red Goshawk [942]	Vulnerable	Species or species habitat likely to occur within area
Erythrura gouldiae Gouldian Finch [413]	Endangered	Species or species habitat known to occur within area
Falco hypoleucos Grey Falcon [929]	Vulnerable	Species or species habitat known to occur within area
Falcunculus frontatus whitei Crested Shrike-tit (northern), Northern Shrike-tit [26013]	Vulnerable	Species or species habitat likely to occur within area
Fregata andrewsi Christmas Island Frigatebird, Andrew's Frigatebird [1011]	Endangered	Breeding known to occur within area
Geophaps smithii blaauwi Partridge Pigeon (western) [66501]	Vulnerable	Species or species habitat likely to occur within area
Leipoa ocellata Malleefowl [934]	Vulnerable	Species or species habitat likely to occur within area
Limosa lapponica baueri Bar-tailed Godwit (baueri), Western Alaskan Bar-tailed Godwit [86380]	Vulnerable	Species or species habitat known to occur within area
Limosa lapponica menzbieri Northern Siberian Bar-tailed Godwit, Bar-tailed Godwit (menzbieri) [86432]	Critically Endangered	Species or species habitat known to occur within area
Macronectes giganteus Southern Giant-Petrel, Southern Giant Petrel	Endangered	Species or species

Name	Status	Type of Presence
[1060]		habitat may occur within area
Macronectes halli Northern Giant Petrel [1061]	Vulnerable	Species or species habitat may occur within area
Malurus leucopterus edouardi White-winged Fairy-wren (Barrow Island), Barrow Island Black-and-white Fairy-wren [26194]	Vulnerable	Species or species habitat likely to occur within area
Ninox natalis Christmas Island Hawk-Owl, Christmas Boobook [66671]	Vulnerable	Species or species habitat known to occur within area
Numenius madagascariensis Eastern Curlew, Far Eastern Curlew [847]	Critically Endangered	Species or species habitat known to occur within area
Papasula abbotti Abbott's Booby [59297]	Endangered	Species or species habitat known to occur within area
Pezoporus occidentalis Night Parrot [59350]	Endangered	Species or species habitat may occur within area
Phaethon lepturus fulvus Christmas Island White-tailed Tropicbird, Golden Bosunbird [26021]	Endangered	Breeding likely to occur within area
Polytelis alexandrae Princess Parrot, Alexandra's Parrot [758]	Vulnerable	Species or species habitat known to occur within area
Pterodroma arminjoniana Round Island Petrel, Trinidade Petrel [89284]	Critically Endangered	Species or species habitat may occur within area
Pterodroma mollis Soft-plumaged Petrel [1036]	Vulnerable	Foraging, feeding or related behaviour likely to occur within area
Rostratula australis Australian Painted Snipe [77037]	Endangered	Species or species habitat known to occur within area
Sternula nereis nereis Australian Fairy Tern [82950]	Vulnerable	Breeding known to occur within area
Thalassarche carteri Indian Yellow-nosed Albatross [64464]	Vulnerable	Foraging, feeding or related behaviour may occur within area
Thalassarche cauta Shy Albatross [89224]	Endangered	Species or species habitat may occur within area
Thalassarche impavida Campbell Albatross, Campbell Black-browed Albatross [64459]	Vulnerable	Species or species habitat may occur within area
Thalassarche melanophris Black-browed Albatross [66472]	Vulnerable	Species or species habitat may occur within area
Thalassarche steadi White-capped Albatross [64462]	Vulnerable	Foraging, feeding or related behaviour likely to occur within area
Turdus poliocephalus erythropleurus Christmas Island Thrush [67122]	Endangered	Species or species habitat likely to occur within area

Name	Status	Type of Presence
Turnix varius scintillans Painted Button-quail (Houtman Abrolhos) [82451]	Vulnerable	Species or species habitat likely to occur within area
Tyto novaehollandiae kimberli Masked Owl (northern) [26048]	Vulnerable	Species or species habitat may occur within area
Fish		
Milyeringa veritas Blind Gudgeon [66676]	Vulnerable	Species or species habitat known to occur within area
Ophisternon candidum Blind Cave Eel [66678]	Vulnerable	Species or species habitat known to occur within area
Mammals		
Balaenoptera borealis Sei Whale [34]	Vulnerable	Foraging, feeding or related behaviour likely to occur within area
Balaenoptera musculus Blue Whale [36]	Endangered	Migration route known to occur within area
Balaenoptera physalus Fin Whale [37]	Vulnerable	Foraging, feeding or related behaviour likely to occur within area
Bettongia lesueur Barrow and Boodie Islands subspecies Boodie, Burrowing Bettong (Barrow and Boodie Islands) [88021]	Vulnerable	Species or species habitat known to occur within area
Bettongia lesueur lesueur Burrowing Bettong (Shark Bay), Boodie [66659]	Vulnerable	Species or species habitat likely to occur within area
Crocidura trichura Christmas Island Shrew [86568]	Critically Endangered	Species or species habitat likely to occur within area
Dasyurus geoffroii Chuditch, Western Quoll [330]	Vulnerable	Species or species habitat likely to occur within area
Dasyurus hallucatus Northern Quoll, Digul [Gogo-Yimidir], Wijingadda [Dambimangari], Wiminji [Martu] [331]	Endangered	Species or species habitat known to occur within area
Eubalaena australis Southern Right Whale [40]	Endangered	Species or species habitat likely to occur within area
Isoodon auratus auratus Golden Bandicoot (mainland) [66665]	Vulnerable	Species or species habitat likely to occur within area
Isoodon auratus barrowensis Golden Bandicoot (Barrow Island) [66666]	Vulnerable	Species or species habitat known to occur within area
Lagorchestes conspicillatus conspicillatus Spectacled Hare-wallaby (Barrow Island) [66661]	Vulnerable	Species or species habitat known to occur within area
Lagorchestes hirsutus Central Australian subspecies Mala, Rufous Hare-Wallaby (Central Australia) [88019]	Endangered	Translocated population known to occur within area
Lagorchestes hirsutus dorrae Rufous Hare-wallaby (Dorre Island) [66663]	Vulnerable	Species or species habitat known to occur within area

Name	Status	Type of Presence
Lagostrophus fasciatus fasciatus Banded Hare-wallaby, Merrnine, Marnine, Munning [66664]	Vulnerable	Species or species habitat known to occur within area
Macroderma gigas Ghost Bat [174]	Vulnerable	Species or species habitat known to occur within area
Macrotis lagotis Greater Bilby [282]	Vulnerable	Species or species habitat known to occur within area
Megaptera novaeangliae Humpback Whale [38]	Vulnerable	Breeding known to occur within area
Neophoca cinerea Australian Sea-lion, Australian Sea Lion [22]	Vulnerable	Species or species habitat likely to occur within area
Osphranter robustus isabellinus Barrow Island Wallaroo, Barrow Island Euro [89262]	Vulnerable	Species or species habitat likely to occur within area
Perameles bougainville bougainville Western Barred Bandicoot (Shark Bay) [66631]	Endangered	Species or species habitat known to occur within area
Petrogale concinna monastria Nabarlek (Kimberley) [87607]	Endangered	Species or species habitat known to occur within area
Petrogale lateralis lateralis Black-flanked Rock-wallaby, Moororong, Black-footed Rock Wallaby [66647]	Endangered	Species or species habitat known to occur within area
Phascogale tapoatafa kimberleyensis Kimberley brush-tailed phascogale, Brush-tailed Phascogale (Kimberley) [88453]	Vulnerable	Species or species habitat likely to occur within area
Pipistrellus murrayi Christmas Island Pipistrelle [64383]	Critically Endangered	Species or species habitat known to occur within area
Pteropus natalis Christmas Island Flying-fox, Christmas Island Fruit-bat [87611]	Critically Endangered	Roosting known to occur within area
Rhinonictis aurantia (Pilbara form) Pilbara Leaf-nosed Bat [82790]	Vulnerable	Species or species habitat known to occur within area
Saccolaimus saccolaimus nudicluniatus Bare-rumped Sheath-tailed Bat, Bare-rumped Sheath-tail Bat [66889]	Vulnerable	Species or species habitat likely to occur within area
Xeromys myoides Water Mouse, False Water Rat, Yirrkoo [66]	Vulnerable	Species or species habitat may occur within area
Other		
Idiosoma nigrum Shield-backed Trapdoor Spider, Black Rugose Trapdoor Spider [66798]	Vulnerable	Species or species habitat known to occur within area
Kumonga exleyi Cape Range Remipede [86875]	Vulnerable	Species or species habitat known to occur within area
Plants		
Asplenium listeri Christmas Island Spleenwort [65865]	Critically Endangered	Species or species habitat known to occur within area

Name	Status	Type of Presence
Caladenia barbarella Small Dragon Orchid, Common Dragon Orchid [68686]	Endangered	Species or species habitat may occur within area
Caladenia hoffmanii Hoffman's Spider-orchid [56719]	Endangered	Species or species habitat likely to occur within area
Pneumatopteris truncata fern [68812]	Critically Endangered	Species or species habitat known to occur within area
Seringia exastia Fringed Fire-bush [88920]	Critically Endangered	Species or species habitat known to occur within area
Tectaria devexa [14767]	Endangered	Species or species habitat likely to occur within area
Reptiles		
Aipysurus apraefrontalis Short-nosed Seasnake [1115]	Critically Endangered	Species or species habitat known to occur within area
Aipysurus foliosquama Leaf-scaled Seasnake [1118]	Critically Endangered	Species or species habitat known to occur within area
Caretta caretta Loggerhead Turtle [1763]	Endangered	Breeding known to occur within area
Chelonia mydas Green Turtle [1765]	Vulnerable	Breeding known to occur within area
Cryptoblepharus egeriae Christmas Island Blue-tailed Skink, Blue-tailed Snake-eyed Skink [1526]	Critically Endangered	Species or species habitat likely to occur within area
Ctenotus zasticus Hamelin Ctenotus [25570]	Vulnerable	Species or species habitat known to occur within area
Cyrtodactylus sadleiri Christmas Island Giant Gecko [86865]	Endangered	Species or species habitat known to occur within area
Dermochelys coriacea Leatherback Turtle, Leathery Turtle, Luth [1768]	Endangered	Foraging, feeding or related behaviour known to occur within area
Egernia stokesii badia Western Spiny-tailed Skink, Baudin Island Spiny-tailed Skink [64483]	Endangered	Species or species habitat likely to occur within area
Emoia nativitatis Christmas Island Forest Skink, Christmas Island Whiptail-skink [1400]	Critically Endangered	Species or species habitat known to occur within area
Eretmochelys imbricata Hawksbill Turtle [1766]	Vulnerable	Breeding known to occur within area
Lepidochelys olivacea Olive Ridley Turtle, Pacific Ridley Turtle [1767]	Endangered	Breeding likely to occur within area
Lepidodactylus listeri Christmas Island Gecko, Lister's Gecko [1711]	Critically Endangered	Species or species habitat known to occur within area
Lerista neviniae Nevin's Slider [85296]	Endangered	Species or species habitat known to occur within area

Name	Status	Type of Presence
Liasis olivaceus barroni Olive Python (Pilbara subspecies) [66699]	Vulnerable	Species or species habitat known to occur within area
Natator depressus Flatback Turtle [59257]	Vulnerable	Breeding known to occur within area
Ramphotyphlops exocoeti Christmas Island Blind Snake, Christmas Island Pink Blind Snake [1262]	Vulnerable	Species or species habitat likely to occur within area
Sharks		
Carcharias taurus (west coast population) Grey Nurse Shark (west coast population) [68752]	Vulnerable	Species or species habitat known to occur within area
Carcharodon carcharias White Shark, Great White Shark [64470]	Vulnerable	Species or species habitat known to occur within area
Glyphis garricki Northern River Shark, New Guinea River Shark [82454]	Endangered	Breeding likely to occur within area
Pristis clavata Dwarf Sawfish, Queensland Sawfish [68447]	Vulnerable	Breeding known to occur within area
Pristis pristis Freshwater Sawfish, Largetooth Sawfish, River Sawfish, Leichhardt's Sawfish, Northern Sawfish [60756]	Vulnerable	Species or species habitat known to occur within area
Pristis zijsron Green Sawfish, Dindagubba, Narrowsnout Sawfish [68442]	Vulnerable	Breeding known to occur within area
Rhincodon typus Whale Shark [66680]	Vulnerable	Foraging, feeding or related behaviour known to occur within area

Listed Migratory Species [\[Resource Information \]](#)

* Species is listed under a different scientific name on the EPBC Act - Threatened Species list.

Name	Threatened	Type of Presence
Migratory Marine Birds		
Anous stolidus Common Noddy [825]		Breeding known to occur within area
Apus pacificus Fork-tailed Swift [678]		Species or species habitat likely to occur within area
Ardenna carneipes Flesh-footed Shearwater, Fleshy-footed Shearwater [82404]		Foraging, feeding or related behaviour likely to occur within area
Ardenna pacifica Wedge-tailed Shearwater [84292]		Breeding known to occur within area
Calonectris leucomelas Streaked Shearwater [1077]		Species or species habitat known to occur within area
Diomedea amsterdamensis Amsterdam Albatross [64405]	Endangered	Species or species habitat likely to occur within area
Diomedea epomophora Southern Royal Albatross [89221]	Vulnerable	Species or species habitat may occur within area
Diomedea exulans Wandering Albatross [89223]	Vulnerable	Species or species habitat may occur within area

Name	Threatened	Type of Presence
Fregata andrewsi Christmas Island Frigatebird, Andrew's Frigatebird [1011]	Endangered	Breeding known to occur within area
Fregata ariel Lesser Frigatebird, Least Frigatebird [1012]		Breeding known to occur within area
Fregata minor Great Frigatebird, Greater Frigatebird [1013]		Breeding known to occur within area
Hydroprogne caspia Caspian Tern [808]		Breeding known to occur within area
Macronectes giganteus Southern Giant-Petrel, Southern Giant Petrel [1060]	Endangered	Species or species habitat may occur within area
Macronectes halli Northern Giant Petrel [1061]	Vulnerable	Species or species habitat may occur within area
Onychoprion anaethetus Bridled Tern [82845]		Breeding known to occur within area
Phaethon lepturus White-tailed Tropicbird [1014]		Breeding known to occur within area
Phaethon rubricauda Red-tailed Tropicbird [994]		Breeding known to occur within area
Sterna dougallii Roseate Tern [817]		Breeding known to occur within area
Sternula albifrons Little Tern [82849]		Breeding known to occur within area
Sula dactylatra Masked Booby [1021]		Breeding known to occur within area
Sula leucogaster Brown Booby [1022]		Breeding known to occur within area
Sula sula Red-footed Booby [1023]		Breeding known to occur within area
Thalassarche carteri Indian Yellow-nosed Albatross [64464]	Vulnerable	Foraging, feeding or related behaviour may occur within area
Thalassarche cauta Shy Albatross [89224]	Endangered	Species or species habitat may occur within area
Thalassarche impavida Campbell Albatross, Campbell Black-browed Albatross [64459]	Vulnerable	Species or species habitat may occur within area
Thalassarche melanophris Black-browed Albatross [66472]	Vulnerable	Species or species habitat may occur within area
Thalassarche steadi White-capped Albatross [64462]	Vulnerable	Foraging, feeding or related behaviour likely to occur within area
Migratory Marine Species		
Anoxypristis cuspidata Narrow Sawfish, Knifetooth Sawfish [68448]		Species or species habitat known to occur within area
Balaena glacialis australis Southern Right Whale [75529]	Endangered*	Species or species habitat likely to occur

Name	Threatened	Type of Presence within area
Balaenoptera bonaerensis Antarctic Minke Whale, Dark-shoulder Minke Whale [67812]		Species or species habitat likely to occur within area
Balaenoptera borealis Sei Whale [34]	Vulnerable	Foraging, feeding or related behaviour likely to occur within area
Balaenoptera edeni Bryde's Whale [35]		Species or species habitat likely to occur within area
Balaenoptera musculus Blue Whale [36]	Endangered	Migration route known to occur within area
Balaenoptera physalus Fin Whale [37]	Vulnerable	Foraging, feeding or related behaviour likely to occur within area
Carcharhinus longimanus Oceanic Whitetip Shark [84108]		Species or species habitat likely to occur within area
Carcharodon carcharias White Shark, Great White Shark [64470]	Vulnerable	Species or species habitat known to occur within area
Caretta caretta Loggerhead Turtle [1763]	Endangered	Breeding known to occur within area
Chelonia mydas Green Turtle [1765]	Vulnerable	Breeding known to occur within area
Crocodylus porosus Salt-water Crocodile, Estuarine Crocodile [1774]		Species or species habitat likely to occur within area
Dermochelys coriacea Leatherback Turtle, Leathery Turtle, Luth [1768]	Endangered	Foraging, feeding or related behaviour known to occur within area
Dugong dugon Dugong [28]		Breeding known to occur within area
Eretmochelys imbricata Hawksbill Turtle [1766]	Vulnerable	Breeding known to occur within area
Isurus oxyrinchus Shortfin Mako, Mako Shark [79073]		Species or species habitat likely to occur within area
Isurus paucus Longfin Mako [82947]		Species or species habitat likely to occur within area
Lamna nasus Porbeagle, Mackerel Shark [83288]		Species or species habitat may occur within area
Lepidochelys olivacea Olive Ridley Turtle, Pacific Ridley Turtle [1767]	Endangered	Breeding likely to occur within area
Manta alfredi Reef Manta Ray, Coastal Manta Ray, Inshore Manta Ray, Prince Alfred's Ray, Resident Manta Ray [84994]		Species or species habitat known to occur within area
Manta birostris Giant Manta Ray, Chevron Manta Ray, Pacific Manta Ray, Pelagic Manta Ray, Oceanic Manta Ray [84995]		Species or species habitat known to occur within area
Megaptera novaeangliae Humpback Whale [38]	Vulnerable	Breeding known to occur

Name	Threatened	Type of Presence within area
Natator depressus Flatback Turtle [59257]	Vulnerable	Breeding known to occur within area
Orcaella heinsohni Australian Snubfin Dolphin [81322]		Species or species habitat known to occur within area
Orcinus orca Killer Whale, Orca [46]		Species or species habitat may occur within area
Physeter macrocephalus Sperm Whale [59]		Species or species habitat may occur within area
Pristis clavata Dwarf Sawfish, Queensland Sawfish [68447]	Vulnerable	Breeding known to occur within area
Pristis pristis Freshwater Sawfish, Largetooth Sawfish, River Sawfish, Leichhardt's Sawfish, Northern Sawfish [60756]	Vulnerable	Species or species habitat known to occur within area
Pristis zijsron Green Sawfish, Dindagubba, Narrowsnout Sawfish [68442]	Vulnerable	Breeding known to occur within area
Rhincodon typus Whale Shark [66680]	Vulnerable	Foraging, feeding or related behaviour known to occur within area
Sousa chinensis Indo-Pacific Humpback Dolphin [50]		Breeding known to occur within area
Tursiops aduncus (Arafura/Timor Sea populations) Spotted Bottlenose Dolphin (Arafura/Timor Sea populations) [78900]		Species or species habitat known to occur within area
Migratory Terrestrial Species		
Cecropis daurica Red-rumped Swallow [80610]		Species or species habitat known to occur within area
Cuculus optatus Oriental Cuckoo, Horsfield's Cuckoo [86651]		Species or species habitat known to occur within area
Hirundo rustica Barn Swallow [662]		Species or species habitat known to occur within area
Motacilla cinerea Grey Wagtail [642]		Species or species habitat known to occur within area
Motacilla flava Yellow Wagtail [644]		Species or species habitat known to occur within area
Migratory Wetlands Species		
Acrocephalus orientalis Oriental Reed-Warbler [59570]		Species or species habitat known to occur within area
Actitis hypoleucos Common Sandpiper [59309]		Species or species habitat known to occur within area
Arenaria interpres Ruddy Turnstone [872]		Roosting known to occur within area
Calidris acuminata Sharp-tailed Sandpiper [874]		Roosting known to occur

Name	Threatened	Type of Presence
Calidris alba Sanderling [875]		within area Roosting known to occur within area
Calidris canutus Red Knot, Knot [855]	Endangered	Species or species habitat known to occur within area
Calidris ferruginea Curlew Sandpiper [856]	Critically Endangered	Species or species habitat known to occur within area
Calidris melanotos Pectoral Sandpiper [858]		Species or species habitat known to occur within area
Calidris ruficollis Red-necked Stint [860]		Roosting known to occur within area
Calidris subminuta Long-toed Stint [861]		Species or species habitat known to occur within area
Calidris tenuirostris Great Knot [862]	Critically Endangered	Roosting known to occur within area
Charadrius bicinctus Double-banded Plover [895]		Roosting known to occur within area
Charadrius leschenaultii Greater Sand Plover, Large Sand Plover [877]	Vulnerable	Roosting known to occur within area
Charadrius mongolus Lesser Sand Plover, Mongolian Plover [879]	Endangered	Roosting known to occur within area
Charadrius veredus Oriental Plover, Oriental Dotterel [882]		Roosting known to occur within area
Gallinago megala Swinhoe's Snipe [864]		Roosting likely to occur within area
Gallinago stenura Pin-tailed Snipe [841]		Roosting likely to occur within area
Glareola maldivarum Oriental Pratincole [840]		Roosting known to occur within area
Limicola falcinellus Broad-billed Sandpiper [842]		Roosting known to occur within area
Limnodromus semipalmatus Asian Dowitcher [843]		Roosting known to occur within area
Limosa lapponica Bar-tailed Godwit [844]		Species or species habitat known to occur within area
Limosa limosa Black-tailed Godwit [845]		Roosting known to occur within area
Numenius madagascariensis Eastern Curlew, Far Eastern Curlew [847]	Critically Endangered	Species or species habitat known to occur within area
Numenius minutus Little Curlew, Little Whimbrel [848]		Roosting known to occur within area
Numenius phaeopus Whimbrel [849]		Roosting known to occur within area
Pandion haliaetus Osprey [952]		Breeding known to occur

Name	Threatened	Type of Presence within area
Phalaropus lobatus Red-necked Phalarope [838]		Species or species habitat known to occur within area
Philomachus pugnax Ruff (Reeve) [850]		Roosting known to occur within area
Pluvialis fulva Pacific Golden Plover [25545]		Roosting known to occur within area
Pluvialis squatarola Grey Plover [865]		Roosting known to occur within area
Thalasseus bergii Crested Tern [83000]		Breeding known to occur within area
Tringa brevipes Grey-tailed Tattler [851]		Roosting known to occur within area
Tringa glareola Wood Sandpiper [829]		Roosting known to occur within area
Tringa nebularia Common Greenshank, Greenshank [832]		Species or species habitat known to occur within area
Tringa stagnatilis Marsh Sandpiper, Little Greenshank [833]		Roosting known to occur within area
Tringa totanus Common Redshank, Redshank [835]		Roosting known to occur within area
Xenus cinereus Terek Sandpiper [59300]		Roosting known to occur within area

Other Matters Protected by the EPBC Act

Commonwealth Land [\[Resource Information \]](#)

The Commonwealth area listed below may indicate the presence of Commonwealth land in this vicinity. Due to the unreliability of the data source, all proposals should be checked as to whether it impacts on a Commonwealth area, before making a definitive decision. Contact the State or Territory government land department for further information.

Name
Commonwealth Land - Commonwealth Land - Christmas Island National Park Defence - BROOME TRAINING DEPOT Defence - EXMOUTH ADMIN & HF TRANSMITTING Defence - EXMOUTH VLF TRANSMITTER STATION Defence - LEARMONTH - AIR WEAPONS RANGE Defence - LEARMONTH RADAR SITE - VLAMING HEAD EXMOUTH Defence - YAMPI SOUND TRAINING AREA

Commonwealth Heritage Places [\[Resource Information \]](#)

Name	State	Status
Natural		
Ashmore Reef National Nature Reserve	EXT	Listed place
Christmas Island Natural Areas	EXT	Listed place
Learmonth Air Weapons Range Facility	WA	Listed place
Mermaid Reef - Rowley Shoals	WA	Listed place
Ningaloo Marine Area - Commonwealth Waters	WA	Listed place
Scott Reef and Surrounds - Commonwealth Area	EXT	Listed place
Yampi Defence Area	WA	Listed place
Historic		
Administrators House Precinct	EXT	Listed place
Bungalow 702	EXT	Listed place
Drumsite Industrial Area	EXT	Listed place
HMAS Sydney II and HSK Kormoran Shipwreck Sites	EXT	Listed place

Name	State	Status
Industrial and Administrative Group	EXT	Listed place
Malay Kampong Group	EXT	Listed place
Malay Kampong Precinct	EXT	Listed place
Phosphate Hill Historic Area	EXT	Listed place
Poon Saan Group	EXT	Listed place
Settlement Christmas Island	EXT	Listed place
South Point Settlement Remains	EXT	Listed place

Listed Marine Species [\[Resource Information \]](#)

* Species is listed under a different scientific name on the EPBC Act - Threatened Species list.

Name	Threatened	Type of Presence
Birds		
Acrocephalus orientalis Oriental Reed-Warbler [59570]		Species or species habitat known to occur within area
Actitis hypoleucos Common Sandpiper [59309]		Species or species habitat known to occur within area
Anous minutus Black Noddy [824]		Breeding known to occur within area
Anous stolidus Common Noddy [825]		Breeding known to occur within area
Anous tenuirostris melanops Australian Lesser Noddy [26000]	Vulnerable	Breeding known to occur within area
Anseranas semipalmata Magpie Goose [978]		Species or species habitat may occur within area
Apus pacificus Fork-tailed Swift [678]		Species or species habitat likely to occur within area
Ardea alba Great Egret, White Egret [59541]		Breeding known to occur within area
Ardea ibis Cattle Egret [59542]		Species or species habitat may occur within area
Arenaria interpres Ruddy Turnstone [872]		Roosting known to occur within area
Calidris acuminata Sharp-tailed Sandpiper [874]		Roosting known to occur within area
Calidris alba Sanderling [875]		Roosting known to occur within area
Calidris canutus Red Knot, Knot [855]	Endangered	Species or species habitat known to occur within area
Calidris ferruginea Curlew Sandpiper [856]	Critically Endangered	Species or species habitat known to occur within area
Calidris melanotos Pectoral Sandpiper [858]		Species or species habitat known to occur within area
Calidris ruficollis Red-necked Stint [860]		Roosting known to occur within area
Calidris subminuta Long-toed Stint [861]		Species or species habitat known to occur within area

Name	Threatened	Type of Presence
Calidris tenuirostris Great Knot [862]	Critically Endangered	Roosting known to occur within area
Calonectris leucomelas Streaked Shearwater [1077]		Species or species habitat known to occur within area
Catharacta skua Great Skua [59472]		Species or species habitat may occur within area
Charadrius bicinctus Double-banded Plover [895]		Roosting known to occur within area
Charadrius leschenaultii Greater Sand Plover, Large Sand Plover [877]	Vulnerable	Roosting known to occur within area
Charadrius mongolus Lesser Sand Plover, Mongolian Plover [879]	Endangered	Roosting known to occur within area
Charadrius ruficapillus Red-capped Plover [881]		Roosting known to occur within area
Charadrius veredus Oriental Plover, Oriental Dotterel [882]		Roosting known to occur within area
Chrysococcyx osculans Black-eared Cuckoo [705]		Species or species habitat known to occur within area
Diomedea amsterdamensis Amsterdam Albatross [64405]	Endangered	Species or species habitat likely to occur within area
Diomedea epomophora Southern Royal Albatross [89221]	Vulnerable	Species or species habitat may occur within area
Diomedea exulans Wandering Albatross [89223]	Vulnerable	Species or species habitat may occur within area
Fregata andrewsi Christmas Island Frigatebird, Andrew's Frigatebird [1011]	Endangered	Breeding known to occur within area
Fregata ariel Lesser Frigatebird, Least Frigatebird [1012]		Breeding known to occur within area
Fregata minor Great Frigatebird, Greater Frigatebird [1013]		Breeding known to occur within area
Gallinago megala Swinhoe's Snipe [864]		Roosting likely to occur within area
Gallinago stenura Pin-tailed Snipe [841]		Roosting likely to occur within area
Glareola maldivarum Oriental Pratincole [840]		Roosting known to occur within area
Haliaeetus leucogaster White-bellied Sea-Eagle [943]		Breeding known to occur within area
Heteroscelus brevipes Grey-tailed Tattler [59311]		Roosting known to occur within area
Himantopus himantopus Pied Stilt, Black-winged Stilt [870]		Roosting known to occur within area
Hirundo daurica Red-rumped Swallow [59480]		Species or species habitat known to occur

Name	Threatened	Type of Presence within area
Hirundo rustica Barn Swallow [662]		Species or species habitat known to occur within area
Larus novaehollandiae Silver Gull [810]		Breeding known to occur within area
Larus pacificus Pacific Gull [811]		Breeding known to occur within area
Limicola falcinellus Broad-billed Sandpiper [842]		Roosting known to occur within area
Limnodromus semipalmatus Asian Dowitcher [843]		Roosting known to occur within area
Limosa lapponica Bar-tailed Godwit [844]		Species or species habitat known to occur within area
Limosa limosa Black-tailed Godwit [845]		Roosting known to occur within area
Macronectes giganteus Southern Giant-Petrel, Southern Giant Petrel [1060]	Endangered	Species or species habitat may occur within area
Macronectes halli Northern Giant Petrel [1061]	Vulnerable	Species or species habitat may occur within area
Merops ornatus Rainbow Bee-eater [670]		Species or species habitat may occur within area
Motacilla cinerea Grey Wagtail [642]		Species or species habitat known to occur within area
Motacilla flava Yellow Wagtail [644]		Species or species habitat known to occur within area
Numenius madagascariensis Eastern Curlew, Far Eastern Curlew [847]	Critically Endangered	Species or species habitat known to occur within area
Numenius minutus Little Curlew, Little Whimbrel [848]		Roosting known to occur within area
Numenius phaeopus Whimbrel [849]		Roosting known to occur within area
Pandion haliaetus Osprey [952]		Breeding known to occur within area
Papasula abbotti Abbott's Booby [59297]	Endangered	Species or species habitat known to occur within area
Phaethon lepturus White-tailed Tropicbird [1014]		Breeding known to occur within area
Phaethon lepturus fulvus Christmas Island White-tailed Tropicbird, Golden Bosunbird [26021]	Endangered	Breeding likely to occur within area
Phaethon rubricauda Red-tailed Tropicbird [994]		Breeding known to occur within area
Phalacrocorax fuscescens Black-faced Cormorant [59660]		Breeding likely to occur

Name	Threatened	Type of Presence
Phalaropus lobatus Red-necked Phalarope [838]		within area Species or species habitat known to occur within area
Philomachus pugnax Ruff (Reeve) [850]		Roosting known to occur within area
Pluvialis fulva Pacific Golden Plover [25545]		Roosting known to occur within area
Pluvialis squatarola Grey Plover [865]		Roosting known to occur within area
Pterodroma macroptera Great-winged Petrel [1035]		Foraging, feeding or related behaviour known to occur within area
Pterodroma mollis Soft-plumaged Petrel [1036]	Vulnerable	Foraging, feeding or related behaviour likely to occur within area
Puffinus assimilis Little Shearwater [59363]		Foraging, feeding or related behaviour known to occur within area
Puffinus carneipes Flesh-footed Shearwater, Fleshy-footed Shearwater [1043]		Foraging, feeding or related behaviour likely to occur within area
Puffinus pacificus Wedge-tailed Shearwater [1027]		Breeding known to occur within area
Recurvirostra novaehollandiae Red-necked Avocet [871]		Roosting known to occur within area
Rostratula benghalensis (sensu lato) Painted Snipe [889]	Endangered*	Species or species habitat known to occur within area
Sterna albifrons Little Tern [813]		Breeding known to occur within area
Sterna anaethetus Bridled Tern [814]		Breeding known to occur within area
Sterna bengalensis Lesser Crested Tern [815]		Breeding known to occur within area
Sterna bergii Crested Tern [816]		Breeding known to occur within area
Sterna caspia Caspian Tern [59467]		Breeding known to occur within area
Sterna dougallii Roseate Tern [817]		Breeding known to occur within area
Sterna fuscata Sooty Tern [794]		Breeding known to occur within area
Sterna nereis Fairy Tern [796]		Breeding known to occur within area
Stiltia isabella Australian Pratincole [818]		Roosting known to occur within area
Sula dactylatra Masked Booby [1021]		Breeding known to occur within area
Sula leucogaster Brown Booby [1022]		Breeding known to occur

Name	Threatened	Type of Presence within area
Sula sula Red-footed Booby [1023]		Breeding known to occur within area
Thalassarche carteri Indian Yellow-nosed Albatross [64464]	Vulnerable	Foraging, feeding or related behaviour may occur within area
Thalassarche cauta Shy Albatross [89224]	Endangered	Species or species habitat may occur within area
Thalassarche impavida Campbell Albatross, Campbell Black-browed Albatross [64459]	Vulnerable	Species or species habitat may occur within area
Thalassarche melanophris Black-browed Albatross [66472]	Vulnerable	Species or species habitat may occur within area
Thalassarche steadi White-capped Albatross [64462]	Vulnerable	Foraging, feeding or related behaviour likely to occur within area
Tringa glareola Wood Sandpiper [829]		Roosting known to occur within area
Tringa nebularia Common Greenshank, Greenshank [832]		Species or species habitat known to occur within area
Tringa stagnatilis Marsh Sandpiper, Little Greenshank [833]		Roosting known to occur within area
Tringa totanus Common Redshank, Redshank [835]		Roosting known to occur within area
Xenus cinereus Terek Sandpiper [59300]		Roosting known to occur within area
Fish		
Acentronura australe Southern Pygmy Pipehorse [66185]		Species or species habitat may occur within area
Acentronura larsonae Helen's Pygmy Pipehorse [66186]		Species or species habitat may occur within area
Bhanotia fasciolata Corrugated Pipefish, Barbed Pipefish [66188]		Species or species habitat may occur within area
Bulbonaricus brauni Braun's Pughead Pipefish, Pug-headed Pipefish [66189]		Species or species habitat may occur within area
Campichthys galei Gale's Pipefish [66191]		Species or species habitat may occur within area
Campichthys tricarinatus Three-keel Pipefish [66192]		Species or species habitat may occur within area
Choeroichthys brachysoma Pacific Short-bodied Pipefish, Short-bodied Pipefish [66194]		Species or species habitat may occur within area
Choeroichthys latispinosus Muiron Island Pipefish [66196]		Species or species habitat may occur within area

Name	Threatened	Type of Presence
Choeroichthys sculptus Sculptured Pipefish [66197]		Species or species habitat may occur within area
Choeroichthys suillus Pig-snouted Pipefish [66198]		Species or species habitat may occur within area
Corythoichthys amplexus Fijian Banded Pipefish, Brown-banded Pipefish [66199]		Species or species habitat may occur within area
Corythoichthys flavofasciatus Reticulate Pipefish, Yellow-banded Pipefish, Network Pipefish [66200]		Species or species habitat may occur within area
Corythoichthys haematopterus Reef-top Pipefish [66201]		Species or species habitat may occur within area
Corythoichthys intestinalis Australian Messmate Pipefish, Banded Pipefish [66202]		Species or species habitat may occur within area
Corythoichthys schultzi Schultz's Pipefish [66205]		Species or species habitat may occur within area
Cosmocampus banneri Roughridge Pipefish [66206]		Species or species habitat may occur within area
Cosmocampus maxweberi Maxweber's Pipefish [66209]		Species or species habitat may occur within area
Doryrhamphus baldwini Redstripe Pipefish [66718]		Species or species habitat may occur within area
Doryrhamphus dactyliophorus Banded Pipefish, Ringed Pipefish [66210]		Species or species habitat may occur within area
Doryrhamphus excisus Bluestripe Pipefish, Indian Blue-stripe Pipefish, Pacific Blue-stripe Pipefish [66211]		Species or species habitat may occur within area
Doryrhamphus janssi Cleaner Pipefish, Janss' Pipefish [66212]		Species or species habitat may occur within area
Doryrhamphus multiannulatus Many-banded Pipefish [66717]		Species or species habitat may occur within area
Doryrhamphus negrosensis Flagtail Pipefish, Masthead Island Pipefish [66213]		Species or species habitat may occur within area
Festucalex scalaris Ladder Pipefish [66216]		Species or species habitat may occur within area
Filicampus tigris Tiger Pipefish [66217]		Species or species habitat may occur within area
Halicampus brocki Brock's Pipefish [66219]		Species or species habitat may occur within area

Name	Threatened	Type of Presence
Halicampus dunckeri Red-hair Pipefish, Duncker's Pipefish [66220]		Species or species habitat may occur within area
Halicampus grayi Mud Pipefish, Gray's Pipefish [66221]		Species or species habitat may occur within area
Halicampus macrorhynchus Whiskered Pipefish, Ornate Pipefish [66222]		Species or species habitat may occur within area
Halicampus mataafae Samoan Pipefish [66223]		Species or species habitat may occur within area
Halicampus nitidus Glittering Pipefish [66224]		Species or species habitat may occur within area
Halicampus spirostris Spiny-snout Pipefish [66225]		Species or species habitat may occur within area
Haliichthys taeniophorus Ribboned Pipehorse, Ribboned Seadragon [66226]		Species or species habitat may occur within area
Hippichthys cyanospilos Blue-speckled Pipefish, Blue-spotted Pipefish [66228]		Species or species habitat may occur within area
Hippichthys heptagonus Madura Pipefish, Reticulated Freshwater Pipefish [66229]		Species or species habitat may occur within area
Hippichthys penicillus Beady Pipefish, Steep-nosed Pipefish [66231]		Species or species habitat may occur within area
Hippichthys spicifer Belly-barred Pipefish, Banded Freshwater Pipefish [66232]		Species or species habitat may occur within area
Hippocampus angustus Western Spiny Seahorse, Narrow-bellied Seahorse [66234]		Species or species habitat may occur within area
Hippocampus breviceps Short-head Seahorse, Short-snouted Seahorse [66235]		Species or species habitat may occur within area
Hippocampus histrix Spiny Seahorse, Thorny Seahorse [66236]		Species or species habitat may occur within area
Hippocampus kuda Spotted Seahorse, Yellow Seahorse [66237]		Species or species habitat may occur within area
Hippocampus planifrons Flat-face Seahorse [66238]		Species or species habitat may occur within area
Hippocampus spinosissimus Hedgehog Seahorse [66239]		Species or species habitat may occur within area
Hippocampus subelongatus West Australian Seahorse [66722]		Species or species habitat may occur within area

Name	Threatened	Type of Presence
Hippocampus trimaculatus Three-spot Seahorse, Low-crowned Seahorse, Flat-faced Seahorse [66720]		Species or species habitat may occur within area
Lissocampus fatiloquus Prophet's Pipefish [66250]		Species or species habitat may occur within area
Maroubra perserrata Sawtooth Pipefish [66252]		Species or species habitat may occur within area
Micrognathus brevirostris thorntail Pipefish, Thorn-tailed Pipefish [66254]		Species or species habitat may occur within area
Micrognathus micronotopterus Tidepool Pipefish [66255]		Species or species habitat may occur within area
Mitotichthys meraculus Western Crested Pipefish [66259]		Species or species habitat may occur within area
Nannocampus subosseus Bonyhead Pipefish, Bony-headed Pipefish [66264]		Species or species habitat may occur within area
Phoxocampus belcheri Black Rock Pipefish [66719]		Species or species habitat may occur within area
Phycodurus eques Leafy Seadragon [66267]		Species or species habitat may occur within area
Phyllopteryx taeniolatus Common Seadragon, Weedy Seadragon [66268]		Species or species habitat may occur within area
Pugnaso curtirostris Pugnose Pipefish, Pug-nosed Pipefish [66269]		Species or species habitat may occur within area
Solegnathus hardwickii Pallid Pipehorse, Hardwick's Pipehorse [66272]		Species or species habitat may occur within area
Solegnathus lettiensis Gunther's Pipehorse, Indonesian Pipefish [66273]		Species or species habitat may occur within area
Solenostomus cyanopterus Robust Ghostpipefish, Blue-finned Ghost Pipefish, [66183]		Species or species habitat may occur within area
Stigmatopora argus Spotted Pipefish, Gulf Pipefish, Peacock Pipefish [66276]		Species or species habitat may occur within area
Stigmatopora nigra Widebody Pipefish, Wide-bodied Pipefish, Black Pipefish [66277]		Species or species habitat may occur within area
Syngnathoides biaculeatus Double-end Pipehorse, Double-ended Pipehorse, Alligator Pipefish [66279]		Species or species habitat may occur within area
Trachyrhamphus bicoarctatus Bentstick Pipefish, Bend Stick Pipefish, Short-tailed Pipefish [66280]		Species or species habitat may occur within area

Name	Threatened	Type of Presence
Trachyrhamphus longirostris Straightstick Pipefish, Long-nosed Pipefish, Straight Stick Pipefish [66281]		Species or species habitat may occur within area
Urocampus carinirostris Hairy Pipefish [66282]		Species or species habitat may occur within area
Vanacampus margaritifer Mother-of-pearl Pipefish [66283]		Species or species habitat may occur within area
Mammals		
Arctocephalus forsteri Long-nosed Fur-seal, New Zealand Fur-seal [20]		Species or species habitat may occur within area
Dugong dugon Dugong [28]		Breeding known to occur within area
Neophoca cinerea Australian Sea-lion, Australian Sea Lion [22]	Vulnerable	Species or species habitat likely to occur within area
Reptiles		
Acalyptophis peronii Horned Seasnake [1114]		Species or species habitat may occur within area
Aipysurus apraefrontalis Short-nosed Seasnake [1115]	Critically Endangered	Species or species habitat known to occur within area
Aipysurus duboisii Dubois' Seasnake [1116]		Species or species habitat may occur within area
Aipysurus eydouxii Spine-tailed Seasnake [1117]		Species or species habitat may occur within area
Aipysurus foliosquama Leaf-scaled Seasnake [1118]	Critically Endangered	Species or species habitat known to occur within area
Aipysurus fuscus Dusky Seasnake [1119]		Species or species habitat known to occur within area
Aipysurus laevis Olive Seasnake [1120]		Species or species habitat may occur within area
Aipysurus pooleorum Shark Bay Seasnake [66061]		Species or species habitat may occur within area
Aipysurus tenuis Brown-lined Seasnake [1121]		Species or species habitat may occur within area
Astrotia stokesii Stokes' Seasnake [1122]		Species or species habitat may occur within area
Caretta caretta Loggerhead Turtle [1763]	Endangered	Breeding known to occur within area
Chelonia mydas Green Turtle [1765]	Vulnerable	Breeding known to occur within area
Crocodylus johnstoni Freshwater Crocodile, Johnston's Crocodile,		Species or species

Name	Threatened	Type of Presence
Johnston's River Crocodile [1773] Crocodylus porosus		habitat may occur within area
Salt-water Crocodile, Estuarine Crocodile [1774] Dermochelys coriacea		Species or species habitat likely to occur within area
Leatherback Turtle, Leathery Turtle, Luth [1768] Disteira kingii	Endangered	Foraging, feeding or related behaviour known to occur within area
Spectacled Seasnake [1123] Disteira major		Species or species habitat may occur within area
Olive-headed Seasnake [1124] Emydocephalus annulatus		Species or species habitat may occur within area
Turtle-headed Seasnake [1125] Enhydrina schistosa		Species or species habitat may occur within area
Beaked Seasnake [1126] Ephalophis greyi		Species or species habitat may occur within area
North-western Mangrove Seasnake [1127] Eretmochelys imbricata		Species or species habitat may occur within area
Hawksbill Turtle [1766] Hydrelaps darwiniensis	Vulnerable	Breeding known to occur within area
Black-ringed Seasnake [1100] Hydrophis coggeri		Species or species habitat may occur within area
Slender-necked Seasnake [25925] Hydrophis czeblukovi		Species or species habitat may occur within area
Fine-spined Seasnake [59233] Hydrophis elegans		Species or species habitat may occur within area
Elegant Seasnake [1104] Hydrophis mcdowellii		Species or species habitat may occur within area
null [25926] Hydrophis ornatus		Species or species habitat may occur within area
Spotted Seasnake, Ornate Reef Seasnake [1111] Lapemis hardwickii		Species or species habitat may occur within area
Spine-bellied Seasnake [1113] Lepidochelys olivacea		Species or species habitat may occur within area
Olive Ridley Turtle, Pacific Ridley Turtle [1767] Natator depressus	Endangered	Breeding likely to occur within area
Flatback Turtle [59257] Pelamis platurus	Vulnerable	Breeding known to occur within area
Yellow-bellied Seasnake [1091]		Species or species habitat may occur within area

Name	Status	Type of Presence
Mammals		
Balaenoptera acutorostrata Minke Whale [33]		Species or species habitat may occur within area
Balaenoptera bonaerensis Antarctic Minke Whale, Dark-shoulder Minke Whale [67812]		Species or species habitat likely to occur within area
Balaenoptera borealis Sei Whale [34]	Vulnerable	Foraging, feeding or related behaviour likely to occur within area
Balaenoptera edeni Bryde's Whale [35]		Species or species habitat likely to occur within area
Balaenoptera musculus Blue Whale [36]	Endangered	Migration route known to occur within area
Balaenoptera physalus Fin Whale [37]	Vulnerable	Foraging, feeding or related behaviour likely to occur within area
Delphinus delphis Common Dolphin, Short-beaked Common Dolphin [60]		Species or species habitat may occur within area
Eubalaena australis Southern Right Whale [40]	Endangered	Species or species habitat likely to occur within area
Feresa attenuata Pygmy Killer Whale [61]		Species or species habitat may occur within area
Globicephala macrorhynchus Short-finned Pilot Whale [62]		Species or species habitat may occur within area
Globicephala melas Long-finned Pilot Whale [59282]		Species or species habitat may occur within area
Grampus griseus Risso's Dolphin, Grampus [64]		Species or species habitat may occur within area
Indopacetus pacificus Longman's Beaked Whale [72]		Species or species habitat may occur within area
Kogia breviceps Pygmy Sperm Whale [57]		Species or species habitat may occur within area
Kogia simus Dwarf Sperm Whale [58]		Species or species habitat may occur within area
Lagenodelphis hosei Fraser's Dolphin, Sarawak Dolphin [41]		Species or species habitat may occur within area
Megaptera novaeangliae Humpback Whale [38]	Vulnerable	Breeding known to occur within area
Mesoplodon densirostris Blainville's Beaked Whale, Dense-beaked Whale [74]		Species or species habitat may occur within area
Mesoplodon ginkgodens Ginkgo-toothed Beaked Whale, Ginkgo-toothed		Species or species

Name	Status	Type of Presence
Whale, Ginkgo Beaked Whale [59564] Mesoplodon grayi		habitat may occur within area
Gray's Beaked Whale, Scamperdown Whale [75] Orcaella brevirostris		Species or species habitat may occur within area
Irrawaddy Dolphin [45] Orcinus orca		Species or species habitat known to occur within area
Killer Whale, Orca [46] Peponocephala electra		Species or species habitat may occur within area
Melon-headed Whale [47] Physeter macrocephalus		Species or species habitat may occur within area
Sperm Whale [59] Pseudorca crassidens		Species or species habitat likely to occur within area
False Killer Whale [48] Sousa chinensis		Breeding known to occur within area
Indo-Pacific Humpback Dolphin [50] Stenella attenuata		Species or species habitat may occur within area
Spotted Dolphin, Pantropical Spotted Dolphin [51] Stenella coeruleoalba		Species or species habitat may occur within area
Striped Dolphin, Euphrosyne Dolphin [52] Stenella longirostris		Species or species habitat may occur within area
Long-snouted Spinner Dolphin [29] Steno bredanensis		Species or species habitat may occur within area
Rough-toothed Dolphin [30] Tursiops aduncus		Species or species habitat likely to occur within area
Indian Ocean Bottlenose Dolphin, Spotted Bottlenose Dolphin [68418] Tursiops aduncus (Arafura/Timor Sea populations)		Species or species habitat known to occur within area
Spotted Bottlenose Dolphin (Arafura/Timor Sea populations) [78900] Tursiops truncatus s. str.		Species or species habitat may occur within area
Bottlenose Dolphin [68417] Ziphius cavirostris		Species or species habitat may occur within area
Cuvier's Beaked Whale, Goose-beaked Whale [56]		Species or species habitat may occur within area

Commonwealth ReservesTerrestrial [\[Resource Information \]](#)

Name	State	Type
Christmas Island	EXT	National Park (Commonwealth)

Australian Marine Parks [\[Resource Information \]](#)

Name	Label
Abrolhos	Habitat Protection Zone (IUCN IV)
Abrolhos	Multiple Use Zone (IUCN VI)

Name	Label
Abrolhos	National Park Zone (IUCN II)
Abrolhos	Special Purpose Zone (IUCN VI)
Argo-Rowley Terrace	Multiple Use Zone (IUCN VI)
Argo-Rowley Terrace	National Park Zone (IUCN II)
Argo-Rowley Terrace	Special Purpose Zone (Trawl) (IUCN VI)
Ashmore Reef	Recreational Use Zone (IUCN IV)
Ashmore Reef	Sanctuary Zone (IUCN Ia)
Carnarvon Canyon	Habitat Protection Zone (IUCN IV)
Cartier Island	Sanctuary Zone (IUCN Ia)
Dampier	Habitat Protection Zone (IUCN IV)
Dampier	Multiple Use Zone (IUCN VI)
Dampier	National Park Zone (IUCN II)
Eighty Mile Beach	Multiple Use Zone (IUCN VI)
Gascoyne	Habitat Protection Zone (IUCN IV)
Gascoyne	Multiple Use Zone (IUCN VI)
Gascoyne	National Park Zone (IUCN II)
Kimberley	Habitat Protection Zone (IUCN IV)
Kimberley	Multiple Use Zone (IUCN VI)
Kimberley	National Park Zone (IUCN II)
Mermaid Reef	National Park Zone (IUCN II)
Montebello	Multiple Use Zone (IUCN VI)
Ningaloo	National Park Zone (IUCN II)
Ningaloo	Recreational Use Zone (IUCN IV)
Roebuck	Multiple Use Zone (IUCN VI)
Shark Bay	Multiple Use Zone (IUCN VI)

Extra Information

State and Territory Reserves	[Resource Information]
Name	State
Adele Island	WA
Airlie Island	WA
Bardi Jawi	WA
Barrow Island	WA
Bedout Island	WA
Bernier And Dorre Islands	WA
Bessieres Island	WA
Boodie, Double Middle Islands	WA
Browse Island	WA
Bundegi Coastal Park	WA
Cape Range	WA
Coulomb Point	WA
Dambimangari	WA
Dambimangari	WA
Gnandaroo Island	WA
Jarrkunpungu	WA
Jinmarnkur	WA
Jinmarnkur Kulja	WA
Jurabi Coastal Park	WA
Karajarri	WA
Kujungurru Warrarn	WA
Kujungurru Warrarn	WA
Lacepede Islands	WA
Little Rocky Island	WA
Locker Island	WA
Lowendal Islands	WA
Montebello Islands	WA
Muiron Islands	WA
Murujuga	WA
North Sandy Island	WA
North Turtle Island	WA
Nyangumarta Warrarn	WA
Part Murchison house	WA
Round Island	WA
Serrurier Island	WA
Swan Island	WA

Name	State
Tanner Island	WA
Unnamed WA28968	WA
Unnamed WA36907	WA
Unnamed WA36909	WA
Unnamed WA36910	WA
Unnamed WA36913	WA
Unnamed WA36915	WA
Unnamed WA37168	WA
Unnamed WA40322	WA
Unnamed WA40828	WA
Unnamed WA40877	WA
Unnamed WA41080	WA
Unnamed WA41775	WA
Unnamed WA44665	WA
Unnamed WA44667	WA
Unnamed WA44669	WA
Unnamed WA44672	WA
Unnamed WA44673	WA
Unnamed WA51105	WA
Unnamed WA51162	WA
Unnamed WA51497	WA
Unnamed WA51617	WA
Unnamed WA51932	WA
Unnamed WA52354	WA
Unnamed WA52366	WA
Unnamed WA53015	WA
Victor Island	WA
Weld Island	WA
Y Island	WA
Yampi	WA
Yawuru	WA
Zuytdorp	WA

Invasive Species [\[Resource Information \]](#)

Weeds reported here are the 20 species of national significance (WoNS), along with other introduced plants that are considered by the States and Territories to pose a particularly significant threat to biodiversity. The following feral animals are reported: Goat, Red Fox, Cat, Rabbit, Pig, Water Buffalo and Cane Toad. Maps from Landscape Health Project, National Land and Water Resources Audit, 2001.

Name	Status	Type of Presence
Birds		
Anas platyrhynchos Mallard [974]		Species or species habitat likely to occur within area
Columba livia Rock Pigeon, Rock Dove, Domestic Pigeon [803]		Species or species habitat likely to occur within area
Gallus gallus Red Junglefowl, Feral Chicken, Domestic Fowl [917]		Species or species habitat likely to occur within area
Lonchura oryzivora Java Sparrow [59586]		Species or species habitat likely to occur within area
Meleagris gallopavo Wild Turkey [64380]		Species or species habitat likely to occur within area
Passer domesticus House Sparrow [405]		Species or species habitat likely to occur within area
Passer montanus Eurasian Tree Sparrow [406]		Species or species

Name	Status	Type of Presence
Streptopelia senegalensis		habitat likely to occur within area
Laughing Turtle-dove, Laughing Dove [781]		Species or species habitat likely to occur within area
Sturnus vulgaris		
Common Starling [389]		Species or species habitat likely to occur within area
Frogs		
Rhinella marina		
Cane Toad [83218]		Species or species habitat may occur within area
Mammals		
Bos taurus		
Domestic Cattle [16]		Species or species habitat likely to occur within area
Camelus dromedarius		
Dromedary, Camel [7]		Species or species habitat likely to occur within area
Canis lupus familiaris		
Domestic Dog [82654]		Species or species habitat likely to occur within area
Capra hircus		
Goat [2]		Species or species habitat likely to occur within area
Equus asinus		
Donkey, Ass [4]		Species or species habitat likely to occur within area
Equus caballus		
Horse [5]		Species or species habitat likely to occur within area
Felis catus		
Cat, House Cat, Domestic Cat [19]		Species or species habitat likely to occur within area
Mus musculus		
House Mouse [120]		Species or species habitat likely to occur within area
Oryctolagus cuniculus		
Rabbit, European Rabbit [128]		Species or species habitat likely to occur within area
Rattus exulans		
Pacific Rat, Polynesian Rat [79]		Species or species habitat likely to occur within area
Rattus rattus		
Black Rat, Ship Rat [84]		Species or species habitat likely to occur within area
Sus scrofa		
Pig [6]		Species or species habitat likely to occur within area
Vulpes vulpes		
Red Fox, Fox [18]		Species or species habitat likely to occur within area
Plants		
Andropogon gayanus		
Gamba Grass [66895]		Species or species habitat likely to occur within area

Name	Status	Type of Presence
Cenchrus ciliaris Buffel-grass, Black Buffel-grass [20213]		Species or species habitat likely to occur within area
Dolichandra unguis-cati Cat's Claw Vine, Yellow Trumpet Vine, Cat's Claw Creeper, Funnel Creeper [85119]		Species or species habitat likely to occur within area
Jatropha gossypifolia Cotton-leaved Physic-Nut, Bellyache Bush, Cotton-leaf Physic Nut, Cotton-leaf Jatropha, Black Physic Nut [7507]		Species or species habitat likely to occur within area
Lantana camara Lantana, Common Lantana, Kamara Lantana, Large-leaf Lantana, Pink Flowered Lantana, Red Flowered Lantana, Red-Flowered Sage, White Sage, Wild Sage [10892]		Species or species habitat may occur within area
Opuntia spp. Prickly Pears [82753]		Species or species habitat likely to occur within area
Parkinsonia aculeata Parkinsonia, Jerusalem Thorn, Jelly Bean Tree, Horse Bean [12301]		Species or species habitat likely to occur within area
Prosopis spp. Mesquite, Algaroba [68407]		Species or species habitat likely to occur within area

Reptiles

Hemidactylus frenatus Asian House Gecko [1708]		Species or species habitat likely to occur within area
Lycodon aulicus Wolf Snake, Common Wolf Snake, Asian Wolf Snake [83178]		Species or species habitat likely to occur within area
Lygosoma bowringii Christmas Island Grass-skink [1312]		Species or species habitat likely to occur within area
Ramphotyphlops braminus Flowerpot Blind Snake, Brahminy Blind Snake, Cacing Besi [1258]		Species or species habitat known to occur within area

Nationally Important Wetlands

[[Resource Information](#)]

Name	State
"The Dales", Christmas Island	EXT
Ashmore Reef	EXT
Bundera Sinkhole	WA
Cape Range Subterranean Waterways	WA
Eighty Mile Beach System	WA
Exmouth Gulf East	WA
Hosine's Spring, Christmas Island	EXT
Learmonth Air Weapons Range - Saline Coastal Flats	WA
Leslie (Port Hedland) Saltfields System	WA
Mermaid Reef	EXT
Roebuck Bay	WA
Willie Creek Wetlands	WA
Yampi Sound Training Area	WA

Key Ecological Features (Marine)

[[Resource Information](#)]

Key Ecological Features are the parts of the marine ecosystem that are considered to be important for the biodiversity or ecosystem functioning and integrity of the Commonwealth Marine Area.

Name	Region
Ancient coastline at 125 m depth contour	North-west
Ashmore Reef and Cartier Island and surrounding	North-west

Name	Region
Canyons linking the Argo Abyssal Plain with the	North-west
Canyons linking the Cuvier Abyssal Plain and the	North-west
Commonwealth waters adjacent to Ningaloo Reef	North-west
Continental Slope Demersal Fish Communities	North-west
Exmouth Plateau	North-west
Glomar Shoals	North-west
Mermaid Reef and Commonwealth waters	North-west
Seringapatam Reef and Commonwealth waters in	North-west
Wallaby Saddle	North-west
Ancient coastline at 90-120m depth	South-west
Commonwealth marine environment surrounding	South-west
Perth Canyon and adjacent shelf break, and other	South-west
Western demersal slope and associated fish	South-west
Western rock lobster	South-west

Caveat

The information presented in this report has been provided by a range of data sources as acknowledged at the end of the report.

This report is designed to assist in identifying the locations of places which may be relevant in determining obligations under the Environment Protection and Biodiversity Conservation Act 1999. It holds mapped locations of World and National Heritage properties, Wetlands of International and National Importance, Commonwealth and State/Territory reserves, listed threatened, migratory and marine species and listed threatened ecological communities. Mapping of Commonwealth land is not complete at this stage. Maps have been collated from a range of sources at various resolutions.

Not all species listed under the EPBC Act have been mapped (see below) and therefore a report is a general guide only. Where available data supports mapping, the type of presence that can be determined from the data is indicated in general terms. People using this information in making a referral may need to consider the qualifications below and may need to seek and consider other information sources.

For threatened ecological communities where the distribution is well known, maps are derived from recovery plans, State vegetation maps, remote sensing imagery and other sources. Where threatened ecological community distributions are less well known, existing vegetation maps and point location data are used to produce indicative distribution maps.

Threatened, migratory and marine species distributions have been derived through a variety of methods. Where distributions are well known and if time permits, maps are derived using either thematic spatial data (i.e. vegetation, soils, geology, elevation, aspect, terrain, etc) together with point locations and described habitat; or environmental modelling (MAXENT or BIOCLIM habitat modelling) using point locations and environmental data layers.

Where very little information is available for species or large number of maps are required in a short time-frame, maps are derived either from 0.04 or 0.02 decimal degree cells; by an automated process using polygon capture techniques (static two kilometre grid cells, alpha-hull and convex hull); or captured manually or by using topographic features (national park boundaries, islands, etc). In the early stages of the distribution mapping process (1999-early 2000s) distributions were defined by degree blocks, 100K or 250K map sheets to rapidly create distribution maps. More reliable distribution mapping methods are used to update these distributions as time permits.

Only selected species covered by the following provisions of the EPBC Act have been mapped:

- migratory and
- marine

The following species and ecological communities have not been mapped and do not appear in reports produced from this database:

- threatened species listed as extinct or considered as vagrants
- some species and ecological communities that have only recently been listed
- some terrestrial species that overfly the Commonwealth marine area
- migratory species that are very widespread, vagrant, or only occur in small numbers

The following groups have been mapped, but may not cover the complete distribution of the species:

- non-threatened seabirds which have only been mapped for recorded breeding sites
- seals which have only been mapped for breeding sites near the Australian continent

Such breeding sites may be important for the protection of the Commonwealth Marine environment.

Coordinates

-7.985 100.445,-9.613 105.801,-7.352 106.414,-8.395 109.126,-8.577 109.449,-8.106 110.465,-8.146 110.566,-9.209 112.389,-8.631 114.098,-8.617 114.341,-8.833 115.195,-8.382 115.72,-8.53 116.669,-8.53 116.756,-9.028 116.851,-9.021 117.167,-8.9 117.813,-8.671 118.365,-8.463 119.024,-8.429 119.293,-8.786 120.599,-8.799 121.413,-8.853 121.851,-8.537 123.217,-10.596 123.217,-12.52 123.58,-14.102 123.573,-15.468 124.62,-16.12 124.616,-16.366 124.421,-16.572 123.505,-16.758 122.818,-16.955 122.601,-16.945 122.495,-17.076 122.298,-17.359 122.152,-17.946 122.211,-17.998 122.387,-18.136 122.377,-18.491 121.889,-18.472 121.832,-18.566 121.775,-18.669 121.783,-18.709 121.719,-18.772 121.66,-18.96 121.568,-19.278 121.405,-19.574 121.087,-19.815 120.52,-19.919 120.114,-19.978 119.79,-20.075 119.583,-20.033 119.485,-19.961 119.203,-20.047 119.006,-20.287 118.829,-20.333 118.666,-20.313 118.614,-20.378 118.365,-20.341 118.334,-20.39 118.207,-20.356 118.186,-20.535 117.948,-20.674 117.764,-20.693 117.609,-20.77 117.377,-20.695 117.214,-20.629 117.059,-20.679 116.972,-20.73 116.884,-20.693 116.804,-20.634 116.8,-20.688 116.622,-20.742 116.6,-20.762 116.533,-20.817 116.491,-20.849 116.356,-20.883 116.316,-20.846 116.206,-20.939 116.201,-20.989 116.163,-21.085 115.929,-21.253 115.841,-21.297 115.72,-21.527 115.476,-21.511 115.451,-21.595 115.305,-21.59 115.232,-21.642 115.103,-21.694 115.054,-21.687 114.968,-21.738 114.877,-21.802 114.786,-21.807 114.718,-21.923 114.674,-21.983 114.628,-21.97 114.524,-22.096 114.098,-21.953 114.139,-21.892 114.142,-21.825 114.184,-21.8 114.157,-21.839 114.056,-21.911 113.994,-22.051 113.91,-22.305 113.829,-22.493 113.735,-22.565 113.669,-22.695 113.683,-22.762 113.769,-22.887 113.819,-23.156 113.51,-23.977 112.796,-25.201 113.092,-25.861 112.527,-27.274 114.008,-28.364 113.604,-28.068 111.424,-24.959 108.194,-24.327 108.086,-22.698 105.058,-21.4 103.814,-18.822 100.98,-17.369 101.222,-15.834 99.903,-14.906 98.773,-12.228 96.727,-12.749 100.667,-9.627 101.932,-7.985 100.445

Acknowledgements

This database has been compiled from a range of data sources. The department acknowledges the following custodians who have contributed valuable data and advice:

- [-Office of Environment and Heritage, New South Wales](#)
- [-Department of Environment and Primary Industries, Victoria](#)
- [-Department of Primary Industries, Parks, Water and Environment, Tasmania](#)
- [-Department of Environment, Water and Natural Resources, South Australia](#)
- [-Department of Land and Resource Management, Northern Territory](#)
- [-Department of Environmental and Heritage Protection, Queensland](#)
- [-Department of Parks and Wildlife, Western Australia](#)
- [-Environment and Planning Directorate, ACT](#)
- [-Birdlife Australia](#)
- [-Australian Bird and Bat Banding Scheme](#)
- [-Australian National Wildlife Collection](#)
- [-Natural history museums of Australia](#)
- [-Museum Victoria](#)
- [-Australian Museum](#)
- [-South Australian Museum](#)
- [-Queensland Museum](#)
- [-Online Zoological Collections of Australian Museums](#)
- [-Queensland Herbarium](#)
- [-National Herbarium of NSW](#)
- [-Royal Botanic Gardens and National Herbarium of Victoria](#)
- [-Tasmanian Herbarium](#)
- [-State Herbarium of South Australia](#)
- [-Northern Territory Herbarium](#)
- [-Western Australian Herbarium](#)
- [-Australian National Herbarium, Canberra](#)
- [-University of New England](#)
- [-Ocean Biogeographic Information System](#)
- [-Australian Government, Department of Defence Forestry Corporation, NSW](#)
- [-Geoscience Australia](#)
- [-CSIRO](#)
- [-Australian Tropical Herbarium, Cairns](#)
- [-eBird Australia](#)
- [-Australian Government – Australian Antarctic Data Centre](#)
- [-Museum and Art Gallery of the Northern Territory](#)
- [-Australian Government National Environmental Science Program](#)
- [-Australian Institute of Marine Science](#)
- [-Reef Life Survey Australia](#)
- [-American Museum of Natural History](#)
- [-Queen Victoria Museum and Art Gallery, Inveresk, Tasmania](#)
- [-Tasmanian Museum and Art Gallery, Hobart, Tasmania](#)
- [-Other groups and individuals](#)

The Department is extremely grateful to the many organisations and individuals who provided expert advice and information on numerous draft distributions.

Please feel free to provide feedback via the [Contact Us](#) page.

© Commonwealth of Australia

Department of Agriculture Water and the Environment

GPO Box 858

Canberra City ACT 2601 Australia

+61 2 6274 1111

EMBA

EPBC Protected Matters Report

(December 2020)



EPBC Act Protected Matters Report

This report provides general guidance on matters of national environmental significance and other matters protected by the EPBC Act in the area you have selected.

Information on the coverage of this report and qualifications on data supporting this report are contained in the caveat at the end of the report.

Information is available about [Environment Assessments](#) and the EPBC Act including significance guidelines, forms and application process details.

Report created: 01/12/20 18:56:13

[Summary](#)

[Details](#)

[Matters of NES](#)

[Other Matters Protected by the EPBC Act](#)

[Extra Information](#)

[Caveat](#)

[Acknowledgements](#)



This map may contain data which are ©Commonwealth of Australia (Geoscience Australia), ©PSMA 2015

[Coordinates](#)

[Buffer: 5.0Km](#)

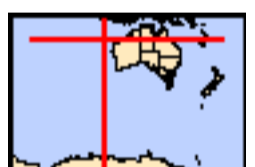

Summary

Matters of National Environmental Significance

This part of the report summarises the matters of national environmental significance that may occur in, or may relate to, the area you nominated. Further information is available in the detail part of the report, which can be accessed by scrolling or following the links below. If you are proposing to undertake an activity that may have a significant impact on one or more matters of national environmental significance then you should consider the [Administrative Guidelines on Significance](#).

World Heritage Properties:	2
National Heritage Places:	5
Wetlands of International Importance:	6
Great Barrier Reef Marine Park:	None
Commonwealth Marine Area:	2
Listed Threatened Ecological Communities:	3
Listed Threatened Species:	124
Listed Migratory Species:	106

Other Matters Protected by the EPBC Act

This part of the report summarises other matters protected under the Act that may relate to the area you nominated. Approval may be required for a proposed activity that significantly affects the environment on Commonwealth land, when the action is outside the Commonwealth land, or the environment anywhere when the action is taken on Commonwealth land. Approval may also be required for the Commonwealth or Commonwealth agencies proposing to take an action that is likely to have a significant impact on the environment anywhere.

The EPBC Act protects the environment on Commonwealth land, the environment from the actions taken on Commonwealth land, and the environment from actions taken by Commonwealth agencies. As heritage values of a place are part of the 'environment', these aspects of the EPBC Act protect the Commonwealth Heritage values of a Commonwealth Heritage place. Information on the new heritage laws can be found at <http://www.environment.gov.au/heritage>

A [permit](#) may be required for activities in or on a Commonwealth area that may affect a member of a listed threatened species or ecological community, a member of a listed migratory species, whales and other cetaceans, or a member of a listed marine species.

Commonwealth Land:	13
Commonwealth Heritage Places:	38
Listed Marine Species:	206
Whales and Other Cetaceans:	41
Critical Habitats:	None
Commonwealth Reserves Terrestrial:	2
Australian Marine Parks:	35

Extra Information

This part of the report provides information that may also be relevant to the area you have nominated.

State and Territory Reserves:	84
Regional Forest Agreements:	None
Invasive Species:	47
Nationally Important Wetlands:	18
Key Ecological Features (Marine)	17

Details

Matters of National Environmental Significance

World Heritage Properties		[Resource Information]
Name	State	Status
Shark Bay, Western Australia	WA	Declared property
The Ningaloo Coast	WA	Declared property

National Heritage Properties		[Resource Information]
Name	State	Status
Natural		
Shark Bay, Western Australia	WA	Listed place
The Ningaloo Coast	WA	Listed place
The West Kimberley	WA	Listed place
Indigenous		
Dampier Archipelago (including Burrup Peninsula)	WA	Listed place
Historic		
HMAS Sydney II and HSK Kormoran Shipwreck Sites	EXT	Listed place

Wetlands of International Importance (Ramsar)		[Resource Information]
Name	Proximity	
Ashmore reef national nature reserve	Within Ramsar site	
Eighty-mile beach	Within Ramsar site	
Hosnies spring	Within Ramsar site	
Pulu keeling national park	Within Ramsar site	
Roebuck bay	Within Ramsar site	
The dales	Within Ramsar site	

Commonwealth Marine Area	[Resource Information]
Approval is required for a proposed activity that is located within the Commonwealth Marine Area which has, will have, or is likely to have a significant impact on the environment. Approval may be required for a proposed action taken outside the Commonwealth Marine Area but which has, may have or is likely to have a significant impact on the environment in the Commonwealth Marine Area. Generally the Commonwealth Marine Area stretches from three nautical miles to two hundred nautical miles from the coast.	

Name
EEZ and Territorial Sea
Extended Continental Shelf

Marine Regions	[Resource Information]
If you are planning to undertake action in an area in or close to the Commonwealth Marine Area, and a marine bioregional plan has been prepared for the Commonwealth Marine Area in that area, the marine bioregional plan may inform your decision as to whether to refer your proposed action under the EPBC Act.	

Name
North-west
South-west

Listed Threatened Ecological Communities	[Resource Information]
For threatened ecological communities where the distribution is well known, maps are derived from recovery plans, State vegetation maps, remote sensing imagery and other sources. Where threatened ecological community distributions are less well known, existing vegetation maps and point location data are used to produce indicative distribution maps.	

Name	Status	Type of Presence
Banksia Woodlands of the Swan Coastal Plain ecological community	Endangered	Community may occur within area
Monsoon vine thickets on the coastal sand dunes of Dampier Peninsula	Endangered	Community likely to occur within area
Tuart (Eucalyptus gomphocephala) Woodlands and Forests of the Swan Coastal Plain ecological community	Critically Endangered	Community may occur within area

Listed Threatened Species	[Resource Information]	
Name	Status	Type of Presence
Birds		

Name	Status	Type of Presence
Accipiter hiogaster natalis Christmas Island Goshawk [82408]	Endangered	Species or species habitat known to occur within area
Anous tenuirostris melanops Australian Lesser Noddy [26000]	Vulnerable	Breeding known to occur within area
Calidris canutus Red Knot, Knot [855]	Endangered	Species or species habitat known to occur within area
Calidris ferruginea Curlew Sandpiper [856]	Critically Endangered	Species or species habitat known to occur within area
Calidris tenuirostris Great Knot [862]	Critically Endangered	Roosting known to occur within area
Calyptorhynchus latirostris Carnaby's Cockatoo, Short-billed Black-Cockatoo [59523]	Endangered	Breeding likely to occur within area
Chalcophaps indica natalis Christmas Island Emerald Dove, Emerald Dove (Christmas Island) [67030]	Endangered	Species or species habitat known to occur within area
Charadrius leschenaultii Greater Sand Plover, Large Sand Plover [877]	Vulnerable	Roosting known to occur within area
Charadrius mongolus Lesser Sand Plover, Mongolian Plover [879]	Endangered	Roosting known to occur within area
Diomedea amsterdamensis Amsterdam Albatross [64405]	Endangered	Species or species habitat likely to occur within area
Diomedea dabbenena Tristan Albatross [66471]	Endangered	Species or species habitat likely to occur within area
Diomedea epomophora Southern Royal Albatross [89221]	Vulnerable	Foraging, feeding or related behaviour likely to occur within area
Diomedea exulans Wandering Albatross [89223]	Vulnerable	Foraging, feeding or related behaviour likely to occur within area
Diomedea sanfordi Northern Royal Albatross [64456]	Endangered	Foraging, feeding or related behaviour likely to occur within area
Erythrotriorchis radiatus Red Goshawk [942]	Vulnerable	Species or species habitat likely to occur within area
Erythrura gouldiae Gouldian Finch [413]	Endangered	Species or species habitat known to occur within area
Falco hypoleucos Grey Falcon [929]	Vulnerable	Species or species habitat known to occur within area
Falcunculus frontatus whitei Crested Shrike-tit (northern), Northern Shrike-tit [26013]	Vulnerable	Species or species habitat likely to occur within area
Fregata andrewsi Christmas Island Frigatebird, Andrew's Frigatebird [1011]	Endangered	Breeding known to occur within area
Geophaps smithii blaauwi Partridge Pigeon (western) [66501]	Vulnerable	Species or species habitat likely to occur

Name	Status	Type of Presence within area
Halobaena caerulea Blue Petrel [1059]	Vulnerable	Species or species habitat may occur within area
Hypotaenidia philippensis andrewsi Buff-banded Rail (Cocos (Keeling) Islands), Ayam Hutan [88994]	Endangered	Species or species habitat known to occur within area
Leipoa ocellata Malleefowl [934]	Vulnerable	Species or species habitat known to occur within area
Limosa lapponica baueri Bar-tailed Godwit (baueri), Western Alaskan Bar-tailed Godwit [86380]	Vulnerable	Species or species habitat known to occur within area
Limosa lapponica menzbieri Northern Siberian Bar-tailed Godwit, Bar-tailed Godwit (menzbieri) [86432]	Critically Endangered	Species or species habitat known to occur within area
Macronectes giganteus Southern Giant-Petrel, Southern Giant Petrel [1060]	Endangered	Species or species habitat may occur within area
Macronectes halli Northern Giant Petrel [1061]	Vulnerable	Species or species habitat may occur within area
Malurus leucopterus edouardi White-winged Fairy-wren (Barrow Island), Barrow Island Black-and-white Fairy-wren [26194]	Vulnerable	Species or species habitat likely to occur within area
Malurus leucopterus leucopterus White-winged Fairy-wren (Dirk Hartog Island), Dirk Hartog Black-and-White Fairy-wren [26004]	Vulnerable	Species or species habitat likely to occur within area
Ninox natalis Christmas Island Hawk-Owl, Christmas Boobook [66671]	Vulnerable	Species or species habitat known to occur within area
Numenius madagascariensis Eastern Curlew, Far Eastern Curlew [847]	Critically Endangered	Species or species habitat known to occur within area
Pachyptila turtur subantarctica Fairy Prion (southern) [64445]	Vulnerable	Species or species habitat may occur within area
Papasula abbotti Abbott's Booby [59297]	Endangered	Species or species habitat known to occur within area
Pezoporus occidentalis Night Parrot [59350]	Endangered	Species or species habitat may occur within area
Phaethon lepturus fulvus Christmas Island White-tailed Tropicbird, Golden Bosunbird [26021]	Endangered	Breeding likely to occur within area
Phoebastria fusca Sooty Albatross [1075]	Vulnerable	Species or species habitat may occur within area
Polytelis alexandrae Princess Parrot, Alexandra's Parrot [758]	Vulnerable	Species or species habitat known to occur within area
Pterodroma arminjoniana Round Island Petrel, Trinidade Petrel [89284]	Critically Endangered	Breeding likely to occur within area
Pterodroma mollis Soft-plumaged Petrel [1036]	Vulnerable	Foraging, feeding or

Name	Status	Type of Presence
Rostratula australis Australian Painted Snipe [77037]	Endangered	related behaviour known to occur within area
Sternula nereis nereis Australian Fairy Tern [82950]	Vulnerable	Breeding known to occur within area
Thalassarche carteri Indian Yellow-nosed Albatross [64464]	Vulnerable	Foraging, feeding or related behaviour may occur within area
Thalassarche cauta Shy Albatross [89224]	Endangered	Foraging, feeding or related behaviour likely to occur within area
Thalassarche impavida Campbell Albatross, Campbell Black-browed Albatross [64459]	Vulnerable	Species or species habitat may occur within area
Thalassarche melanophris Black-browed Albatross [66472]	Vulnerable	Species or species habitat may occur within area
Thalassarche steadi White-capped Albatross [64462]	Vulnerable	Foraging, feeding or related behaviour likely to occur within area
Turdus poliocephalus erythropleurus Christmas Island Thrush [67122]	Endangered	Species or species habitat likely to occur within area
Turnix varius scintillans Painted Button-quail (Houtman Abrolhos) [82451]	Vulnerable	Species or species habitat likely to occur within area
Tyto novaehollandiae kimberli Masked Owl (northern) [26048]	Vulnerable	Species or species habitat may occur within area
Fish		
Milyeringa veritas Blind Gudgeon [66676]	Vulnerable	Species or species habitat known to occur within area
Ophisternon candidum Blind Cave Eel [66678]	Vulnerable	Species or species habitat known to occur within area
Mammals		
Balaenoptera borealis Sei Whale [34]	Vulnerable	Foraging, feeding or related behaviour likely to occur within area
Balaenoptera musculus Blue Whale [36]	Endangered	Foraging, feeding or related behaviour known to occur within area
Balaenoptera physalus Fin Whale [37]	Vulnerable	Foraging, feeding or related behaviour likely to occur within area
Bettongia lesueur Barrow and Boodie Islands subspecies Boodie, Burrowing Bettong (Barrow and Boodie Islands) [88021]	Vulnerable	Species or species habitat known to occur within area
Bettongia lesueur lesueur Burrowing Bettong (Shark Bay), Boodie [66659]	Vulnerable	Species or species habitat likely to occur within area
Bettongia penicillata ogilbyi Woylie [66844]	Endangered	Species or species

Name	Status	Type of Presence
Crocidura trichura Christmas Island Shrew [86568]	Critically Endangered	habitat known to occur within area Species or species habitat likely to occur within area
Dasyurus geoffroii Chuditch, Western Quoll [330]	Vulnerable	Species or species habitat known to occur within area
Dasyurus hallucatus Northern Quoll, Digul [Gogo-Yimidir], Wijingadda [Dambimangari], Wiminji [Martu] [331]	Endangered	Species or species habitat known to occur within area
Eubalaena australis Southern Right Whale [40]	Endangered	Species or species habitat known to occur within area
Isoodon auratus auratus Golden Bandicoot (mainland) [66665]	Vulnerable	Species or species habitat likely to occur within area
Isoodon auratus barrowensis Golden Bandicoot (Barrow Island) [66666]	Vulnerable	Species or species habitat known to occur within area
Lagorchestes conspicillatus conspicillatus Spectacled Hare-wallaby (Barrow Island) [66661]	Vulnerable	Species or species habitat known to occur within area
Lagorchestes hirsutus Central Australian subspecies Mala, Rufous Hare-Wallaby (Central Australia) [88019]	Endangered	Translocated population known to occur within area
Lagorchestes hirsutus dorrae Rufous Hare-wallaby (Dorre Island) [66663]	Vulnerable	Species or species habitat known to occur within area
Lagostrophus fasciatus fasciatus Banded Hare-wallaby, Merrnine, Marnine, Munning [66664]	Vulnerable	Species or species habitat known to occur within area
Macroderma gigas Ghost Bat [174]	Vulnerable	Species or species habitat known to occur within area
Macrotis lagotis Greater Bilby [282]	Vulnerable	Species or species habitat known to occur within area
Megaptera novaeangliae Humpback Whale [38]	Vulnerable	Breeding known to occur within area
Neophoca cinerea Australian Sea-lion, Australian Sea Lion [22]	Vulnerable	Species or species habitat known to occur within area
Osphranter robustus isabellinus Barrow Island Wallaroo, Barrow Island Euro [89262]	Vulnerable	Species or species habitat likely to occur within area
Parantechinus apicalis Dibbler [313]	Endangered	Species or species habitat may occur within area
Perameles bougainville bougainville Western Barred Bandicoot (Shark Bay) [66631]	Endangered	Species or species habitat known to occur within area
Petrogale concinna monastria Nabarlek (Kimberley) [87607]	Endangered	Species or species habitat known to occur within area

Name	Status	Type of Presence
Petrogale lateralis lateralis Black-flanked Rock-wallaby, Moororong, Black-footed Rock Wallaby [66647]	Endangered	Species or species habitat known to occur within area
Phascogale tapoatafa kimberleyensis Kimberley brush-tailed phascogale, Brush-tailed Phascogale (Kimberley) [88453]	Vulnerable	Species or species habitat known to occur within area
Pipistrellus murrayi Christmas Island Pipistrelle [64383]	Critically Endangered	Species or species habitat known to occur within area
Pteropus natalis Christmas Island Flying-fox, Christmas Island Fruit-bat [87611]	Critically Endangered	Roosting known to occur within area
Rhinonictes aurantia (Pilbara form) Pilbara Leaf-nosed Bat [82790]	Vulnerable	Species or species habitat known to occur within area
Saccolaimus saccolaimus nudicluniatus Bare-rumped Sheath-tailed Bat, Bare-rumped Sheath-tail Bat [66889]	Vulnerable	Species or species habitat likely to occur within area
Xeromys myoides Water Mouse, False Water Rat, Yirrkoo [66]	Vulnerable	Species or species habitat may occur within area
Other		
Idiosoma nigrum Shield-backed Trapdoor Spider, Black Rugose Trapdoor Spider [66798]	Vulnerable	Species or species habitat known to occur within area
Kumonga exleyi Cape Range Remipede [86875]	Vulnerable	Species or species habitat known to occur within area
Plants		
Androcalva bivillosa Straggling Androcalva [87807]	Critically Endangered	Species or species habitat may occur within area
Asplenium listeri Christmas Island Spleenwort [65865]	Critically Endangered	Species or species habitat known to occur within area
Beyeria lepidopetala Small-petalled Beyeria, Short-petalled Beyeria [18362]	Endangered	Species or species habitat likely to occur within area
Caladenia barbarella Small Dragon Orchid, Common Dragon Orchid [68686]	Endangered	Species or species habitat may occur within area
Caladenia bryceana subsp. cracens Northern Dwarf Spider-orchid [64556]	Vulnerable	Species or species habitat may occur within area
Caladenia elegans Elegant Spider-orchid [56775]	Endangered	Species or species habitat may occur within area
Caladenia hoffmanii Hoffman's Spider-orchid [56719]	Endangered	Species or species habitat likely to occur within area
Drakaea concolor Kneeling Hammer-orchid [56777]	Vulnerable	Species or species habitat likely to occur within area
Drummondita ericoides Morseby Range Drummondita [9193]	Endangered	Species or species habitat may occur within area

Name	Status	Type of Presence
Lechenaultia chlorantha Kalbarri Leschenaultia [16763]	Vulnerable	Species or species habitat likely to occur within area
Pityrodia augustensis Mt Augustus Foxglove [4962]	Vulnerable	Species or species habitat likely to occur within area
Pneumatopteris truncata fern [68812]	Critically Endangered	Species or species habitat known to occur within area
Seringia exastia Fringed Fire-bush [88920]	Critically Endangered	Species or species habitat known to occur within area
Stachystemon nematophorus Three-flowered Stachystemon [81447]	Vulnerable	Species or species habitat known to occur within area
Tectaria devexa [14767]	Endangered	Species or species habitat likely to occur within area
Wurmbea tubulosa Long-flowered Nancy [12739]	Endangered	Species or species habitat known to occur within area
Reptiles		
Aipysurus apraefrontalis Short-nosed Seasnake [1115]	Critically Endangered	Species or species habitat known to occur within area
Aipysurus foliosquama Leaf-scaled Seasnake [1118]	Critically Endangered	Species or species habitat known to occur within area
Caretta caretta Loggerhead Turtle [1763]	Endangered	Breeding known to occur within area
Chelonia mydas Green Turtle [1765]	Vulnerable	Breeding known to occur within area
Cryptoblepharus egeriae Christmas Island Blue-tailed Skink, Blue-tailed Snake-eyed Skink [1526]	Critically Endangered	Species or species habitat likely to occur within area
Ctenotus zasticus Hamelin Ctenotus [25570]	Vulnerable	Species or species habitat known to occur within area
Cyrtodactylus sadleiri Christmas Island Giant Gecko [86865]	Endangered	Species or species habitat known to occur within area
Dermochelys coriacea Leatherback Turtle, Leathery Turtle, Luth [1768]	Endangered	Foraging, feeding or related behaviour known to occur within area
Egernia stokesii badia Western Spiny-tailed Skink, Baudin Island Spiny-tailed Skink [64483]	Endangered	Species or species habitat known to occur within area
Emoia nativitatis Christmas Island Forest Skink, Christmas Island Whiptail-skink [1400]	Critically Endangered	Species or species habitat known to occur within area
Eretmochelys imbricata Hawksbill Turtle [1766]	Vulnerable	Breeding known to occur within area
Lepidochelys olivacea Olive Ridley Turtle, Pacific Ridley Turtle [1767]	Endangered	Breeding likely to occur within area

Name	Status	Type of Presence
Lepidodactylus listeri Christmas Island Gecko, Lister's Gecko [1711]	Critically Endangered	Species or species habitat known to occur within area
Lerista neviniae Nevin's Slider [85296]	Endangered	Species or species habitat known to occur within area
Liasis olivaceus barroni Olive Python (Pilbara subspecies) [66699]	Vulnerable	Species or species habitat known to occur within area
Natator depressus Flatback Turtle [59257]	Vulnerable	Breeding known to occur within area
Ramphotyphlops exocoeti Christmas Island Blind Snake, Christmas Island Pink Blind Snake [1262]	Vulnerable	Species or species habitat likely to occur within area

Sharks

Carcharias taurus (west coast population) Grey Nurse Shark (west coast population) [68752]	Vulnerable	Species or species habitat known to occur within area
Carcharodon carcharias White Shark, Great White Shark [64470]	Vulnerable	Foraging, feeding or related behaviour known to occur within area
Glyphis garricki Northern River Shark, New Guinea River Shark [82454]	Endangered	Breeding likely to occur within area
Pristis clavata Dwarf Sawfish, Queensland Sawfish [68447]	Vulnerable	Breeding known to occur within area
Pristis pristis Freshwater Sawfish, Largetooth Sawfish, River Sawfish, Leichhardt's Sawfish, Northern Sawfish [60756]	Vulnerable	Species or species habitat known to occur within area
Pristis zijsron Green Sawfish, Dindagubba, Narrowsnout Sawfish [68442]	Vulnerable	Breeding known to occur within area
Rhincodon typus Whale Shark [66680]	Vulnerable	Foraging, feeding or related behaviour known to occur within area

Listed Migratory Species

[[Resource Information](#)]

* Species is listed under a different scientific name on the EPBC Act - Threatened Species list.

Name	Threatened	Type of Presence
Migratory Marine Birds		
Anous stolidus Common Noddy [825]		Breeding known to occur within area
Apus pacificus Fork-tailed Swift [678]		Species or species habitat likely to occur within area
Ardenna carneipes Flesh-footed Shearwater, Fleshy-footed Shearwater [82404]		Foraging, feeding or related behaviour likely to occur within area
Ardenna pacifica Wedge-tailed Shearwater [84292]		Breeding known to occur within area
Calonectris leucomelas Streaked Shearwater [1077]		Species or species habitat known to occur within area
Diomedea amsterdamensis Amsterdam Albatross [64405]	Endangered	Species or species habitat likely to occur within area

Name	Threatened	Type of Presence
Diomedea dabbenena Tristan Albatross [66471]	Endangered	Species or species habitat likely to occur within area
Diomedea epomophora Southern Royal Albatross [89221]	Vulnerable	Foraging, feeding or related behaviour likely to occur within area
Diomedea exulans Wandering Albatross [89223]	Vulnerable	Foraging, feeding or related behaviour likely to occur within area
Diomedea sanfordi Northern Royal Albatross [64456]	Endangered	Foraging, feeding or related behaviour likely to occur within area
Fregata andrewsi Christmas Island Frigatebird, Andrew's Frigatebird [1011]	Endangered	Breeding known to occur within area
Fregata ariel Lesser Frigatebird, Least Frigatebird [1012]		Breeding known to occur within area
Fregata minor Great Frigatebird, Greater Frigatebird [1013]		Breeding known to occur within area
Hydroprogne caspia Caspian Tern [808]		Breeding known to occur within area
Macronectes giganteus Southern Giant-Petrel, Southern Giant Petrel [1060]	Endangered	Species or species habitat may occur within area
Macronectes halli Northern Giant Petrel [1061]	Vulnerable	Species or species habitat may occur within area
Onychoprion anaethetus Bridled Tern [82845]		Breeding known to occur within area
Phaethon lepturus White-tailed Tropicbird [1014]		Breeding known to occur within area
Phaethon rubricauda Red-tailed Tropicbird [994]		Breeding known to occur within area
Phoebetria fusca Sooty Albatross [1075]	Vulnerable	Species or species habitat may occur within area
Sterna dougallii Roseate Tern [817]		Breeding known to occur within area
Sternula albifrons Little Tern [82849]		Breeding known to occur within area
Sula dactylatra Masked Booby [1021]		Breeding known to occur within area
Sula leucogaster Brown Booby [1022]		Breeding known to occur within area
Sula sula Red-footed Booby [1023]		Breeding known to occur within area
Thalassarche carteri Indian Yellow-nosed Albatross [64464]	Vulnerable	Foraging, feeding or related behaviour may occur within area
Thalassarche cauta Shy Albatross [89224]	Endangered	Foraging, feeding or related behaviour likely to occur within area

Name	Threatened	Type of Presence
Thalassarche impavida Campbell Albatross, Campbell Black-browed Albatross [64459]	Vulnerable	Species or species habitat may occur within area
Thalassarche melanophris Black-browed Albatross [66472]	Vulnerable	Species or species habitat may occur within area
Thalassarche steadi White-capped Albatross [64462]	Vulnerable	Foraging, feeding or related behaviour likely to occur within area
Migratory Marine Species		
Anoxypristis cuspidata Narrow Sawfish, Knifetooth Sawfish [68448]		Species or species habitat known to occur within area
Balaena glacialis australis Southern Right Whale [75529]	Endangered*	Species or species habitat known to occur within area
Balaenoptera bonaerensis Antarctic Minke Whale, Dark-shoulder Minke Whale [67812]		Species or species habitat likely to occur within area
Balaenoptera borealis Sei Whale [34]	Vulnerable	Foraging, feeding or related behaviour likely to occur within area
Balaenoptera edeni Bryde's Whale [35]		Species or species habitat likely to occur within area
Balaenoptera musculus Blue Whale [36]	Endangered	Foraging, feeding or related behaviour known to occur within area
Balaenoptera physalus Fin Whale [37]	Vulnerable	Foraging, feeding or related behaviour likely to occur within area
Caperea marginata Pygmy Right Whale [39]		Foraging, feeding or related behaviour likely to occur within area
Carcharhinus longimanus Oceanic Whitetip Shark [84108]		Species or species habitat likely to occur within area
Carcharodon carcharias White Shark, Great White Shark [64470]	Vulnerable	Foraging, feeding or related behaviour known to occur within area
Caretta caretta Loggerhead Turtle [1763]	Endangered	Breeding known to occur within area
Chelonia mydas Green Turtle [1765]	Vulnerable	Breeding known to occur within area
Crocodylus porosus Salt-water Crocodile, Estuarine Crocodile [1774]		Species or species habitat likely to occur within area
Dermochelys coriacea Leatherback Turtle, Leathery Turtle, Luth [1768]	Endangered	Foraging, feeding or related behaviour known to occur within area
Dugong dugon Dugong [28]		Breeding known to occur within area
Eretmochelys imbricata Hawksbill Turtle [1766]	Vulnerable	Breeding known to occur within area

Name	Threatened	Type of Presence
Isurus oxyrinchus Shortfin Mako, Mako Shark [79073]		Species or species habitat likely to occur within area
Isurus paucus Longfin Mako [82947]		Species or species habitat likely to occur within area
Lagenorhynchus obscurus Dusky Dolphin [43]		Species or species habitat likely to occur within area
Lamna nasus Porbeagle, Mackerel Shark [83288]		Species or species habitat may occur within area
Lepidochelys olivacea Olive Ridley Turtle, Pacific Ridley Turtle [1767]	Endangered	Breeding likely to occur within area
Manta alfredi Reef Manta Ray, Coastal Manta Ray, Inshore Manta Ray, Prince Alfred's Ray, Resident Manta Ray [84994]		Species or species habitat known to occur within area
Manta birostris Giant Manta Ray, Chevron Manta Ray, Pacific Manta Ray, Pelagic Manta Ray, Oceanic Manta Ray [84995]		Species or species habitat known to occur within area
Megaptera novaeangliae Humpback Whale [38]	Vulnerable	Breeding known to occur within area
Natator depressus Flatback Turtle [59257]	Vulnerable	Breeding known to occur within area
Orcaella heinsohni Australian Snubfin Dolphin [81322]		Species or species habitat known to occur within area
Orcinus orca Killer Whale, Orca [46]		Species or species habitat may occur within area
Physeter macrocephalus Sperm Whale [59]		Foraging, feeding or related behaviour known to occur within area
Pristis clavata Dwarf Sawfish, Queensland Sawfish [68447]	Vulnerable	Breeding known to occur within area
Pristis pristis Freshwater Sawfish, Largetooth Sawfish, River Sawfish, Leichhardt's Sawfish, Northern Sawfish [60756]	Vulnerable	Species or species habitat known to occur within area
Pristis zijsron Green Sawfish, Dindagubba, Narrowsnout Sawfish [68442]	Vulnerable	Breeding known to occur within area
Rhincodon typus Whale Shark [66680]	Vulnerable	Foraging, feeding or related behaviour known to occur within area
Sousa chinensis Indo-Pacific Humpback Dolphin [50]		Breeding known to occur within area
Tursiops aduncus (Arafura/Timor Sea populations) Spotted Bottlenose Dolphin (Arafura/Timor Sea populations) [78900]		Species or species habitat known to occur within area
Migratory Terrestrial Species		
Cecropis daurica Red-rumped Swallow [80610]		Species or species habitat known to occur within area
Cuculus optatus Oriental Cuckoo, Horsfield's Cuckoo [86651]		Species or species

Name	Threatened	Type of Presence
Hirundo rustica Barn Swallow [662]		habitat known to occur within area Species or species habitat known to occur within area
Motacilla cinerea Grey Wagtail [642]		Species or species habitat known to occur within area
Motacilla flava Yellow Wagtail [644]		Species or species habitat known to occur within area
Migratory Wetlands Species		
Acrocephalus orientalis Oriental Reed-Warbler [59570]		Species or species habitat known to occur within area
Actitis hypoleucos Common Sandpiper [59309]		Species or species habitat known to occur within area
Arenaria interpres Ruddy Turnstone [872]		Roosting known to occur within area
Calidris acuminata Sharp-tailed Sandpiper [874]		Roosting known to occur within area
Calidris alba Sanderling [875]		Roosting known to occur within area
Calidris canutus Red Knot, Knot [855]	Endangered	Species or species habitat known to occur within area
Calidris ferruginea Curlew Sandpiper [856]	Critically Endangered	Species or species habitat known to occur within area
Calidris melanotos Pectoral Sandpiper [858]		Species or species habitat known to occur within area
Calidris ruficollis Red-necked Stint [860]		Roosting known to occur within area
Calidris subminuta Long-toed Stint [861]		Species or species habitat known to occur within area
Calidris tenuirostris Great Knot [862]	Critically Endangered	Roosting known to occur within area
Charadrius bicinctus Double-banded Plover [895]		Roosting known to occur within area
Charadrius leschenaultii Greater Sand Plover, Large Sand Plover [877]	Vulnerable	Roosting known to occur within area
Charadrius mongolus Lesser Sand Plover, Mongolian Plover [879]	Endangered	Roosting known to occur within area
Charadrius veredus Oriental Plover, Oriental Dotterel [882]		Roosting known to occur within area
Gallinago megala Swinhoe's Snipe [864]		Roosting likely to occur within area
Gallinago stenura Pin-tailed Snipe [841]		Roosting likely to occur within area

Name	Threatened	Type of Presence
Glareola maldivarum Oriental Pratincole [840]		Roosting known to occur within area
Limicola falcinellus Broad-billed Sandpiper [842]		Roosting known to occur within area
Limnodromus semipalmatus Asian Dowitcher [843]		Roosting known to occur within area
Limosa lapponica Bar-tailed Godwit [844]		Species or species habitat known to occur within area
Limosa limosa Black-tailed Godwit [845]		Roosting known to occur within area
Numenius madagascariensis Eastern Curlew, Far Eastern Curlew [847]	Critically Endangered	Species or species habitat known to occur within area
Numenius minutus Little Curlew, Little Whimbrel [848]		Roosting known to occur within area
Numenius phaeopus Whimbrel [849]		Roosting known to occur within area
Pandion haliaetus Osprey [952]		Breeding known to occur within area
Phalaropus lobatus Red-necked Phalarope [838]		Species or species habitat known to occur within area
Philomachus pugnax Ruff (Reeve) [850]		Roosting known to occur within area
Pluvialis fulva Pacific Golden Plover [25545]		Roosting known to occur within area
Pluvialis squatarola Grey Plover [865]		Roosting known to occur within area
Thalasseus bergii Crested Tern [83000]		Breeding known to occur within area
Tringa brevipes Grey-tailed Tattler [851]		Roosting known to occur within area
Tringa glareola Wood Sandpiper [829]		Roosting known to occur within area
Tringa nebularia Common Greenshank, Greenshank [832]		Species or species habitat known to occur within area
Tringa stagnatilis Marsh Sandpiper, Little Greenshank [833]		Roosting known to occur within area
Tringa totanus Common Redshank, Redshank [835]		Roosting known to occur within area
Xenus cinereus Terek Sandpiper [59300]		Roosting known to occur within area

Other Matters Protected by the EPBC Act

Commonwealth Land

[[Resource Information](#)]

The Commonwealth area listed below may indicate the presence of Commonwealth land in this vicinity. Due to the unreliability of the data source, all proposals should be checked as to whether it impacts on a Commonwealth area, before making a definitive decision. Contact the State or Territory government land department for further information.

Name

Commonwealth Land -
Commonwealth Land - Christmas Island National Park
Commonwealth Land - Pulu Keeling National Park
Defence - BROOME TRAINING DEPOT
Defence - EXMOUTH ADMIN & HF TRANSMITTING
Defence - EXMOUTH VLF TRANSMITTER STATION
Defence - KARRATHA TRAINING DEPOT
Defence - LEARMONTH - AIR WEAPONS RANGE
Defence - LEARMONTH - RAAF BASE
Defence - LEARMONTH RADAR SITE - TWIN TANKS EXMOUTH
Defence - LEARMONTH RADAR SITE - VLAMING HEAD EXMOUTH
Defence - LEARMONTH TRANSMITTING STATION
Defence - YAMPI SOUND TRAINING AREA

Commonwealth Heritage Places

[[Resource Information](#)]

Name

State

Status

Natural

Ashmore Reef National Nature Reserve	EXT	Listed place
Christmas Island Natural Areas	EXT	Listed place
Learmonth Air Weapons Range Facility	WA	Listed place
Mermaid Reef - Rowley Shoals	WA	Listed place
Ningaloo Marine Area - Commonwealth Waters	WA	Listed place
North Keeling Island	EXT	Listed place
Scott Reef and Surrounds - Commonwealth Area	EXT	Listed place
Yampi Defence Area	WA	Listed place

Historic

Administration Building Forecourt	EXT	Listed place
Administrators House Precinct	EXT	Listed place
Bungalow 702	EXT	Listed place
Captain Ballards Grave	EXT	Listed place
Direction Island (DI) Houses	EXT	Listed place
Drumsite Industrial Area	EXT	Listed place
Early Settlers Graves	EXT	Listed place
Government House	EXT	Listed place
HMAS Sydney II and HSK Kormoran Shipwreck Sites	EXT	Listed place
Home Island Cemetery	EXT	Listed place
Home Island Foreshore	EXT	Listed place
Home Island Industrial Precinct	EXT	Listed place
Industrial and Administrative Group	EXT	Listed place
Malay Kampong Group	EXT	Listed place
Malay Kampong Precinct	EXT	Listed place
Oceania House and Surrounds	EXT	Listed place
Old Co-op Shop (Canteen)	EXT	Listed place
Phosphate Hill Historic Area	EXT	Listed place
Poon Saan Group	EXT	Listed place
Qantas Huts (former)	EXT	Listed place
RAAF Memorial	EXT	Listed place
Settlement Christmas Island	EXT	Listed place
Six Inch Guns	EXT	Listed place
Slipway and Tank	EXT	Listed place
South Point Settlement Remains	EXT	Listed place
Type 2 Residences	EXT	Listed place
Type T Houses Precinct	EXT	Listed place
West Island Elevated Houses	EXT	Listed place
West Island Housing Precinct	EXT	Listed place
West Island Mosque	EXT	Listed place

Listed Marine Species

[[Resource Information](#)]

* Species is listed under a different scientific name on the EPBC Act - Threatened Species list.

Name	Threatened	Type of Presence
Birds		
Acrocephalus orientalis Oriental Reed-Warbler [59570]		Species or species habitat known to occur within area
Actitis hypoleucos Common Sandpiper [59309]		Species or species habitat known to occur within area
Anous minutus Black Noddy [824]		Breeding known to occur within area
Anous stolidus Common Noddy [825]		Breeding known to occur within area
Anous tenuirostris melanops Australian Lesser Noddy [26000]	Vulnerable	Breeding known to occur within area
Anseranas semipalmata Magpie Goose [978]		Species or species habitat may occur within area
Apus pacificus Fork-tailed Swift [678]		Species or species habitat likely to occur within area
Ardea alba Great Egret, White Egret [59541]		Breeding known to occur within area
Ardea ibis Cattle Egret [59542]		Species or species habitat may occur within area
Arenaria interpres Ruddy Turnstone [872]		Roosting known to occur within area
Calidris acuminata Sharp-tailed Sandpiper [874]		Roosting known to occur within area
Calidris alba Sanderling [875]		Roosting known to occur within area
Calidris canutus Red Knot, Knot [855]	Endangered	Species or species habitat known to occur within area
Calidris ferruginea Curlew Sandpiper [856]	Critically Endangered	Species or species habitat known to occur within area
Calidris melanotos Pectoral Sandpiper [858]		Species or species habitat known to occur within area
Calidris ruficollis Red-necked Stint [860]		Roosting known to occur within area
Calidris subminuta Long-toed Stint [861]		Species or species habitat known to occur within area
Calidris tenuirostris Great Knot [862]	Critically Endangered	Roosting known to occur within area
Calonectris leucomelas Streaked Shearwater [1077]		Species or species habitat known to occur within area
Catharacta skua Great Skua [59472]		Species or species habitat may occur within area

Name	Threatened	Type of Presence
Charadrius bicinctus Double-banded Plover [895]		Roosting known to occur within area
Charadrius leschenaultii Greater Sand Plover, Large Sand Plover [877]	Vulnerable	Roosting known to occur within area
Charadrius mongolus Lesser Sand Plover, Mongolian Plover [879]	Endangered	Roosting known to occur within area
Charadrius ruficapillus Red-capped Plover [881]		Roosting known to occur within area
Charadrius veredus Oriental Plover, Oriental Dotterel [882]		Roosting known to occur within area
Chrysococcyx osculans Black-eared Cuckoo [705]		Species or species habitat known to occur within area
Diomedea amsterdamensis Amsterdam Albatross [64405]	Endangered	Species or species habitat likely to occur within area
Diomedea dabbenena Tristan Albatross [66471]	Endangered	Species or species habitat likely to occur within area
Diomedea epomophora Southern Royal Albatross [89221]	Vulnerable	Foraging, feeding or related behaviour likely to occur within area
Diomedea exulans Wandering Albatross [89223]	Vulnerable	Foraging, feeding or related behaviour likely to occur within area
Diomedea sanfordi Northern Royal Albatross [64456]	Endangered	Foraging, feeding or related behaviour likely to occur within area
Fregata andrewsi Christmas Island Frigatebird, Andrew's Frigatebird [1011]	Endangered	Breeding known to occur within area
Fregata ariel Lesser Frigatebird, Least Frigatebird [1012]		Breeding known to occur within area
Fregata minor Great Frigatebird, Greater Frigatebird [1013]		Breeding known to occur within area
Gallinago megala Swinhoe's Snipe [864]		Roosting likely to occur within area
Gallinago stenura Pin-tailed Snipe [841]		Roosting likely to occur within area
Glareola maldivarum Oriental Pratincole [840]		Roosting known to occur within area
Haliaeetus leucogaster White-bellied Sea-Eagle [943]		Breeding known to occur within area
Halobaena caerulea Blue Petrel [1059]	Vulnerable	Species or species habitat may occur within area
Heteroscelus brevipes Grey-tailed Tattler [59311]		Roosting known to occur within area
Himantopus himantopus Pied Stilt, Black-winged Stilt [870]		Roosting known to occur within area
Hirundo daurica Red-rumped Swallow [59480]		Species or species

Name	Threatened	Type of Presence
Hirundo rustica Barn Swallow [662]		habitat known to occur within area Species or species habitat known to occur within area
Larus novaehollandiae Silver Gull [810]		Breeding known to occur within area
Larus pacificus Pacific Gull [811]		Breeding known to occur within area
Limicola falcinellus Broad-billed Sandpiper [842]		Roosting known to occur within area
Limnodromus semipalmatus Asian Dowitcher [843]		Roosting known to occur within area
Limosa lapponica Bar-tailed Godwit [844]		Species or species habitat known to occur within area
Limosa limosa Black-tailed Godwit [845]		Roosting known to occur within area
Macronectes giganteus Southern Giant-Petrel, Southern Giant Petrel [1060]	Endangered	Species or species habitat may occur within area
Macronectes halli Northern Giant Petrel [1061]	Vulnerable	Species or species habitat may occur within area
Merops ornatus Rainbow Bee-eater [670]		Species or species habitat may occur within area
Motacilla cinerea Grey Wagtail [642]		Species or species habitat known to occur within area
Motacilla flava Yellow Wagtail [644]		Species or species habitat known to occur within area
Numenius madagascariensis Eastern Curlew, Far Eastern Curlew [847]	Critically Endangered	Species or species habitat known to occur within area
Numenius minutus Little Curlew, Little Whimbrel [848]		Roosting known to occur within area
Numenius phaeopus Whimbrel [849]		Roosting known to occur within area
Pachyptila turtur Fairy Prion [1066]		Species or species habitat may occur within area
Pandion haliaetus Osprey [952]		Breeding known to occur within area
Papasula abbotti Abbott's Booby [59297]	Endangered	Species or species habitat known to occur within area
Pelagodroma marina White-faced Storm-Petrel [1016]		Breeding known to occur within area
Phaethon lepturus White-tailed Tropicbird [1014]		Breeding known to occur within area

Name	Threatened	Type of Presence
Phaethon lepturus fulvus Christmas Island White-tailed Tropicbird, Golden Bosunbird [26021]	Endangered	Breeding likely to occur within area
Phaethon rubricauda Red-tailed Tropicbird [994]		Breeding known to occur within area
Phalacrocorax fuscescens Black-faced Cormorant [59660]		Breeding likely to occur within area
Phalaropus lobatus Red-necked Phalarope [838]		Species or species habitat known to occur within area
Philomachus pugnax Ruff (Reeve) [850]		Roosting known to occur within area
Phoebastria fusca Sooty Albatross [1075]	Vulnerable	Species or species habitat may occur within area
Pluvialis fulva Pacific Golden Plover [25545]		Roosting known to occur within area
Pluvialis squatarola Grey Plover [865]		Roosting known to occur within area
Pterodroma macroptera Great-winged Petrel [1035]		Foraging, feeding or related behaviour known to occur within area
Pterodroma mollis Soft-plumaged Petrel [1036]	Vulnerable	Foraging, feeding or related behaviour known to occur within area
Puffinus assimilis Little Shearwater [59363]		Breeding known to occur within area
Puffinus carneipes Flesh-footed Shearwater, Fleshy-footed Shearwater [1043]		Foraging, feeding or related behaviour likely to occur within area
Puffinus huttoni Hutton's Shearwater [1025]		Foraging, feeding or related behaviour known to occur within area
Puffinus pacificus Wedge-tailed Shearwater [1027]		Breeding known to occur within area
Recurvirostra novaehollandiae Red-necked Avocet [871]		Roosting known to occur within area
Rostratula benghalensis (sensu lato) Painted Snipe [889]	Endangered*	Species or species habitat known to occur within area
Sterna albifrons Little Tern [813]		Breeding known to occur within area
Sterna anaethetus Bridled Tern [814]		Breeding known to occur within area
Sterna bengalensis Lesser Crested Tern [815]		Breeding known to occur within area
Sterna bergii Crested Tern [816]		Breeding known to occur within area
Sterna caspia Caspian Tern [59467]		Breeding known to occur within area
Sterna dougallii Roseate Tern [817]		Breeding known to occur

Name	Threatened	Type of Presence
Sterna fuscata Sooty Tern [794]		within area Breeding known to occur within area
Sterna nereis Fairy Tern [796]		Breeding known to occur within area
Stiltia isabella Australian Pratincole [818]		Roosting known to occur within area
Sula dactylatra Masked Booby [1021]		Breeding known to occur within area
Sula leucogaster Brown Booby [1022]		Breeding known to occur within area
Sula sula Red-footed Booby [1023]		Breeding known to occur within area
Thalassarche carteri Indian Yellow-nosed Albatross [64464]	Vulnerable	Foraging, feeding or related behaviour may occur within area
Thalassarche cauta Shy Albatross [89224]	Endangered	Foraging, feeding or related behaviour likely to occur within area
Thalassarche impavida Campbell Albatross, Campbell Black-browed Albatross [64459]	Vulnerable	Species or species habitat may occur within area
Thalassarche melanophris Black-browed Albatross [66472]	Vulnerable	Species or species habitat may occur within area
Thalassarche steadi White-capped Albatross [64462]	Vulnerable	Foraging, feeding or related behaviour likely to occur within area
Thinornis rubricollis Hooded Plover [59510]		Species or species habitat known to occur within area
Tringa glareola Wood Sandpiper [829]		Roosting known to occur within area
Tringa nebularia Common Greenshank, Greenshank [832]		Species or species habitat known to occur within area
Tringa stagnatilis Marsh Sandpiper, Little Greenshank [833]		Roosting known to occur within area
Tringa totanus Common Redshank, Redshank [835]		Roosting known to occur within area
Xenus cinereus Terek Sandpiper [59300]		Roosting known to occur within area
Fish		
Acentronura australe Southern Pygmy Pipehorse [66185]		Species or species habitat may occur within area
Acentronura larsonae Helen's Pygmy Pipehorse [66186]		Species or species habitat may occur within area
Bhanotia fasciolata Corrugated Pipefish, Barbed Pipefish [66188]		Species or species habitat may occur within area

Name	Threatened	Type of Presence
Bulbonaricus brauni Braun's Pughead Pipefish, Pug-headed Pipefish [66189]		Species or species habitat may occur within area
Campichthys galei Gale's Pipefish [66191]		Species or species habitat may occur within area
Campichthys tricarinatus Three-keel Pipefish [66192]		Species or species habitat may occur within area
Choeroichthys brachysoma Pacific Short-bodied Pipefish, Short-bodied Pipefish [66194]		Species or species habitat may occur within area
Choeroichthys latispinosus Muiron Island Pipefish [66196]		Species or species habitat may occur within area
Choeroichthys sculptus Sculptured Pipefish [66197]		Species or species habitat may occur within area
Choeroichthys suillus Pig-snouted Pipefish [66198]		Species or species habitat may occur within area
Corythoichthys amplexus Fijian Banded Pipefish, Brown-banded Pipefish [66199]		Species or species habitat may occur within area
Corythoichthys flavofasciatus Reticulate Pipefish, Yellow-banded Pipefish, Network Pipefish [66200]		Species or species habitat may occur within area
Corythoichthys haematopterus Reef-top Pipefish [66201]		Species or species habitat may occur within area
Corythoichthys intestinalis Australian Messmate Pipefish, Banded Pipefish [66202]		Species or species habitat may occur within area
Corythoichthys schultzi Schultz's Pipefish [66205]		Species or species habitat may occur within area
Cosmocampus banneri Roughridge Pipefish [66206]		Species or species habitat may occur within area
Cosmocampus maxweberi Maxweber's Pipefish [66209]		Species or species habitat may occur within area
Doryrhamphus baldwini Redstripe Pipefish [66718]		Species or species habitat may occur within area
Doryrhamphus dactyliophorus Banded Pipefish, Ringed Pipefish [66210]		Species or species habitat may occur within area
Doryrhamphus excisus Bluestripe Pipefish, Indian Blue-stripe Pipefish, Pacific Blue-stripe Pipefish [66211]		Species or species habitat may occur within area
Doryrhamphus janssi Cleaner Pipefish, Janss' Pipefish [66212]		Species or species habitat may occur within area

Name	Threatened	Type of Presence
Doryrhamphus multiannulatus Many-banded Pipefish [66717]		Species or species habitat may occur within area
Doryrhamphus negrosensis Flagtail Pipefish, Masthead Island Pipefish [66213]		Species or species habitat may occur within area
Festucalex scalaris Ladder Pipefish [66216]		Species or species habitat may occur within area
Filicampus tigris Tiger Pipefish [66217]		Species or species habitat may occur within area
Halicampus brocki Brock's Pipefish [66219]		Species or species habitat may occur within area
Halicampus dunckeri Red-hair Pipefish, Duncker's Pipefish [66220]		Species or species habitat may occur within area
Halicampus grayi Mud Pipefish, Gray's Pipefish [66221]		Species or species habitat may occur within area
Halicampus macrorhynchus Whiskered Pipefish, Ornate Pipefish [66222]		Species or species habitat may occur within area
Halicampus mataafae Samoan Pipefish [66223]		Species or species habitat may occur within area
Halicampus nitidus Glittering Pipefish [66224]		Species or species habitat may occur within area
Halicampus spirostris Spiny-snout Pipefish [66225]		Species or species habitat may occur within area
Haliichthys taeniophorus Ribboned Pipehorse, Ribboned Seadragon [66226]		Species or species habitat may occur within area
Heraldia nocturna Upside-down Pipefish, Eastern Upside-down Pipefish, Eastern Upside-down Pipefish [66227]		Species or species habitat may occur within area
Hippichthys cyanospilos Blue-speckled Pipefish, Blue-spotted Pipefish [66228]		Species or species habitat may occur within area
Hippichthys heptagonus Madura Pipefish, Reticulated Freshwater Pipefish [66229]		Species or species habitat may occur within area
Hippichthys penicillus Beady Pipefish, Steep-nosed Pipefish [66231]		Species or species habitat may occur within area
Hippichthys spicifer Belly-barred Pipefish, Banded Freshwater Pipefish [66232]		Species or species habitat may occur within area
Hippocampus angustus Western Spiny Seahorse, Narrow-bellied Seahorse [66234]		Species or species habitat may occur within area

Name	Threatened	Type of Presence
Hippocampus breviceps Short-head Seahorse, Short-snouted Seahorse [66235]		Species or species habitat may occur within area
Hippocampus histrix Spiny Seahorse, Thorny Seahorse [66236]		Species or species habitat may occur within area
Hippocampus kuda Spotted Seahorse, Yellow Seahorse [66237]		Species or species habitat may occur within area
Hippocampus planifrons Flat-face Seahorse [66238]		Species or species habitat may occur within area
Hippocampus spinosissimus Hedgehog Seahorse [66239]		Species or species habitat may occur within area
Hippocampus subelongatus West Australian Seahorse [66722]		Species or species habitat may occur within area
Hippocampus trimaculatus Three-spot Seahorse, Low-crowned Seahorse, Flat-faced Seahorse [66720]		Species or species habitat may occur within area
Histiogamphelus cristatus Rhino Pipefish, Macleay's Crested Pipefish, Ring-back Pipefish [66243]		Species or species habitat may occur within area
Lissocampus caudalis Australian Smooth Pipefish, Smooth Pipefish [66249]		Species or species habitat may occur within area
Lissocampus fatiloquus Prophet's Pipefish [66250]		Species or species habitat may occur within area
Lissocampus runa Javelin Pipefish [66251]		Species or species habitat may occur within area
Maroubra perserrata Sawtooth Pipefish [66252]		Species or species habitat may occur within area
Micrognathus brevirostris thorntail Pipefish, Thorn-tailed Pipefish [66254]		Species or species habitat may occur within area
Micrognathus micronotopterus Tidepool Pipefish [66255]		Species or species habitat may occur within area
Mitotichthys meraculus Western Crested Pipefish [66259]		Species or species habitat may occur within area
Nannocampus subosseus Bonyhead Pipefish, Bony-headed Pipefish [66264]		Species or species habitat may occur within area
Phoxocampus belcheri Black Rock Pipefish [66719]		Species or species habitat may occur within area
Phycodurus eques Leafy Seadragon [66267]		Species or species habitat may occur within area

Name	Threatened	Type of Presence
Phyllopteryx taeniolatus Common Seadragon, Weedy Seadragon [66268]		Species or species habitat may occur within area
Pugnaso curtirostris Pugnose Pipefish, Pug-nosed Pipefish [66269]		Species or species habitat may occur within area
Solegnathus hardwickii Pallid Pipehorse, Hardwick's Pipehorse [66272]		Species or species habitat may occur within area
Solegnathus lettiensis Gunther's Pipehorse, Indonesian Pipefish [66273]		Species or species habitat may occur within area
Solenostomus cyanopterus Robust Ghostpipefish, Blue-finned Ghost Pipefish, [66183]		Species or species habitat may occur within area
Stigmatopora argus Spotted Pipefish, Gulf Pipefish, Peacock Pipefish [66276]		Species or species habitat may occur within area
Stigmatopora nigra Widebody Pipefish, Wide-bodied Pipefish, Black Pipefish [66277]		Species or species habitat may occur within area
Syngnathoides biaculeatus Double-end Pipehorse, Double-ended Pipehorse, Alligator Pipefish [66279]		Species or species habitat may occur within area
Trachyrhamphus bicoarctatus Bentstick Pipefish, Bend Stick Pipefish, Short-tailed Pipefish [66280]		Species or species habitat may occur within area
Trachyrhamphus longirostris Straightstick Pipefish, Long-nosed Pipefish, Straight Stick Pipefish [66281]		Species or species habitat may occur within area
Urocampus carinirostris Hairy Pipefish [66282]		Species or species habitat may occur within area
Vanacampus margaritifer Mother-of-pearl Pipefish [66283]		Species or species habitat may occur within area
Vanacampus phillipi Port Phillip Pipefish [66284]		Species or species habitat may occur within area
Vanacampus poecilolaemus Longsnout Pipefish, Australian Long-snout Pipefish, Long-snouted Pipefish [66285]		Species or species habitat may occur within area
Mammals		
Arctocephalus forsteri Long-nosed Fur-seal, New Zealand Fur-seal [20]		Species or species habitat may occur within area
Dugong dugon Dugong [28]		Breeding known to occur within area
Neophoca cinerea Australian Sea-lion, Australian Sea Lion [22]	Vulnerable	Species or species habitat known to occur within area
Reptiles		
Acalyptophis peronii Horned Seasnake [1114]		Species or species habitat may occur within area

Name	Threatened	Type of Presence
Aipysurus apraefrontalis Short-nosed Seasnake [1115]	Critically Endangered	Species or species habitat known to occur within area
Aipysurus duboisii Dubois' Seasnake [1116]		Species or species habitat may occur within area
Aipysurus eydouxii Spine-tailed Seasnake [1117]		Species or species habitat may occur within area
Aipysurus foliosquama Leaf-scaled Seasnake [1118]	Critically Endangered	Species or species habitat known to occur within area
Aipysurus fuscus Dusky Seasnake [1119]		Species or species habitat known to occur within area
Aipysurus laevis Olive Seasnake [1120]		Species or species habitat may occur within area
Aipysurus pooleorum Shark Bay Seasnake [66061]		Species or species habitat may occur within area
Aipysurus tenuis Brown-lined Seasnake [1121]		Species or species habitat may occur within area
Astrotia stokesii Stokes' Seasnake [1122]		Species or species habitat may occur within area
Caretta caretta Loggerhead Turtle [1763]	Endangered	Breeding known to occur within area
Chelonia mydas Green Turtle [1765]	Vulnerable	Breeding known to occur within area
Crocodylus johnstoni Freshwater Crocodile, Johnston's Crocodile, Johnston's River Crocodile [1773]		Species or species habitat may occur within area
Crocodylus porosus Salt-water Crocodile, Estuarine Crocodile [1774]		Species or species habitat likely to occur within area
Dermochelys coriacea Leatherback Turtle, Leathery Turtle, Luth [1768]	Endangered	Foraging, feeding or related behaviour known to occur within area
Disteira kingii Spectacled Seasnake [1123]		Species or species habitat may occur within area
Disteira major Olive-headed Seasnake [1124]		Species or species habitat may occur within area
Emydocephalus annulatus Turtle-headed Seasnake [1125]		Species or species habitat may occur within area
Enhydrina schistosa Beaked Seasnake [1126]		Species or species habitat may occur within area
Ephalophis greyi North-western Mangrove Seasnake [1127]		Species or species habitat may occur within

Name	Threatened	Type of Presence area
Eretmochelys imbricata Hawksbill Turtle [1766]	Vulnerable	Breeding known to occur within area
Hydrelaps darwiniensis Black-ringed Seasnake [1100]		Species or species habitat may occur within area
Hydrophis coggeri Slender-necked Seasnake [25925]		Species or species habitat may occur within area
Hydrophis czeblukovi Fine-spined Seasnake [59233]		Species or species habitat may occur within area
Hydrophis elegans Elegant Seasnake [1104]		Species or species habitat may occur within area
Hydrophis mcdowellii null [25926]		Species or species habitat may occur within area
Hydrophis ornatus Spotted Seasnake, Ornate Reef Seasnake [1111]		Species or species habitat may occur within area
Lapemis hardwickii Spine-bellied Seasnake [1113]		Species or species habitat may occur within area
Lepidochelys olivacea Olive Ridley Turtle, Pacific Ridley Turtle [1767]	Endangered	Breeding likely to occur within area
Natator depressus Flatback Turtle [59257]	Vulnerable	Breeding known to occur within area
Pelamis platurus Yellow-bellied Seasnake [1091]		Species or species habitat may occur within area
Whales and other Cetaceans		[Resource Information]
Name	Status	Type of Presence
Mammals		
Balaenoptera acutorostrata Minke Whale [33]		Species or species habitat may occur within area
Balaenoptera bonaerensis Antarctic Minke Whale, Dark-shoulder Minke Whale [67812]		Species or species habitat likely to occur within area
Balaenoptera borealis Sei Whale [34]	Vulnerable	Foraging, feeding or related behaviour likely to occur within area
Balaenoptera edeni Bryde's Whale [35]		Species or species habitat likely to occur within area
Balaenoptera musculus Blue Whale [36]	Endangered	Foraging, feeding or related behaviour known to occur within area
Balaenoptera physalus Fin Whale [37]	Vulnerable	Foraging, feeding or related behaviour likely to occur within area
Caperea marginata Pygmy Right Whale [39]		Foraging, feeding or

Name	Status	Type of Presence
Delphinus delphis Common Dolphin, Short-beaked Common Dolphin [60]		related behaviour likely to occur within area Species or species habitat may occur within area
Eubalaena australis Southern Right Whale [40]	Endangered	Species or species habitat known to occur within area
Feresa attenuata Pygmy Killer Whale [61]		Species or species habitat may occur within area
Globicephala macrorhynchus Short-finned Pilot Whale [62]		Species or species habitat may occur within area
Globicephala melas Long-finned Pilot Whale [59282]		Species or species habitat may occur within area
Grampus griseus Risso's Dolphin, Grampus [64]		Species or species habitat may occur within area
Hyperoodon planifrons Southern Bottlenose Whale [71]		Species or species habitat may occur within area
Indopacetus pacificus Longman's Beaked Whale [72]		Species or species habitat may occur within area
Kogia breviceps Pygmy Sperm Whale [57]		Species or species habitat may occur within area
Kogia simus Dwarf Sperm Whale [58]		Species or species habitat may occur within area
Lagenodelphis hosei Fraser's Dolphin, Sarawak Dolphin [41]		Species or species habitat may occur within area
Lagenorhynchus obscurus Dusky Dolphin [43]		Species or species habitat likely to occur within area
Lissodelphis peronii Southern Right Whale Dolphin [44]		Species or species habitat may occur within area
Megaptera novaeangliae Humpback Whale [38]	Vulnerable	Breeding known to occur within area
Mesoplodon bowdoini Andrew's Beaked Whale [73]		Species or species habitat may occur within area
Mesoplodon densirostris Blainville's Beaked Whale, Dense-beaked Whale [74]		Species or species habitat may occur within area
Mesoplodon ginkgodens Ginkgo-toothed Beaked Whale, Ginkgo-toothed Whale, Ginkgo Beaked Whale [59564]		Species or species habitat may occur within area
Mesoplodon grayi Gray's Beaked Whale, Scamperdown Whale [75]		Species or species habitat may occur within area

Name	Status	Type of Presence
Mesoplodon layardii Strap-toothed Beaked Whale, Strap-toothed Whale, Layard's Beaked Whale [25556]		Species or species habitat may occur within area
Mesoplodon mirus True's Beaked Whale [54]		Species or species habitat may occur within area
Orcaella brevirostris Irrawaddy Dolphin [45]		Species or species habitat known to occur within area
Orcinus orca Killer Whale, Orca [46]		Species or species habitat may occur within area
Peponocephala electra Melon-headed Whale [47]		Species or species habitat may occur within area
Physeter macrocephalus Sperm Whale [59]		Foraging, feeding or related behaviour known to occur within area
Pseudorca crassidens False Killer Whale [48]		Species or species habitat likely to occur within area
Sousa chinensis Indo-Pacific Humpback Dolphin [50]		Breeding known to occur within area
Stenella attenuata Spotted Dolphin, Pantropical Spotted Dolphin [51]		Species or species habitat may occur within area
Stenella coeruleoalba Striped Dolphin, Euphrosyne Dolphin [52]		Species or species habitat may occur within area
Stenella longirostris Long-snouted Spinner Dolphin [29]		Species or species habitat may occur within area
Steno bredanensis Rough-toothed Dolphin [30]		Species or species habitat may occur within area
Tursiops aduncus Indian Ocean Bottlenose Dolphin, Spotted Bottlenose Dolphin [68418]		Species or species habitat likely to occur within area
Tursiops aduncus (Arafura/Timor Sea populations) Spotted Bottlenose Dolphin (Arafura/Timor Sea populations) [78900]		Species or species habitat known to occur within area
Tursiops truncatus s. str. Bottlenose Dolphin [68417]		Species or species habitat may occur within area
Ziphius cavirostris Cuvier's Beaked Whale, Goose-beaked Whale [56]		Species or species habitat may occur within area

Commonwealth ReservesTerrestrial [Resource Information]

Name	State	Type
Christmas Island	EXT	National Park (Commonwealth)
Pulu Keeling	EXT	National Park (Commonwealth)

Australian Marine Parks [Resource Information]

Name	Label
Abrolhos	Habitat Protection Zone (IUCN IV)
Abrolhos	Multiple Use Zone (IUCN VI)
Abrolhos	National Park Zone (IUCN II)
Abrolhos	Special Purpose Zone (IUCN VI)
Argo-Rowley Terrace	Multiple Use Zone (IUCN VI)
Argo-Rowley Terrace	National Park Zone (IUCN II)
Argo-Rowley Terrace	Special Purpose Zone (Trawl) (IUCN VI)
Ashmore Reef	Recreational Use Zone (IUCN IV)
Ashmore Reef	Sanctuary Zone (IUCN Ia)
Carnarvon Canyon	Habitat Protection Zone (IUCN IV)
Cartier Island	Sanctuary Zone (IUCN Ia)
Dampier	Habitat Protection Zone (IUCN IV)
Dampier	Multiple Use Zone (IUCN VI)
Dampier	National Park Zone (IUCN II)
Eighty Mile Beach	Multiple Use Zone (IUCN VI)
Gascoyne	Habitat Protection Zone (IUCN IV)
Gascoyne	Multiple Use Zone (IUCN VI)
Gascoyne	National Park Zone (IUCN II)
Jurien	National Park Zone (IUCN II)
Jurien	Special Purpose Zone (IUCN VI)
Kimberley	Habitat Protection Zone (IUCN IV)
Kimberley	Multiple Use Zone (IUCN VI)
Kimberley	National Park Zone (IUCN II)
Mermaid Reef	National Park Zone (IUCN II)
Montebello	Multiple Use Zone (IUCN VI)
Ningaloo	National Park Zone (IUCN II)
Ningaloo	Recreational Use Zone (IUCN IV)
Perth Canyon	Habitat Protection Zone (IUCN IV)
Perth Canyon	Multiple Use Zone (IUCN VI)
Perth Canyon	National Park Zone (IUCN II)
Roebuck	Multiple Use Zone (IUCN VI)
Shark Bay	Multiple Use Zone (IUCN VI)
South-west Corner	National Park Zone (IUCN II)
South-west Corner	Special Purpose Zone (Mining)
Two Rocks	Multiple Use Zone (IUCN VI)

Extra Information

State and Territory Reserves	[Resource Information]
Name	State
Adele Island	WA
Airlie Island	WA
Bardi Jawi	WA
Barrow Island	WA
Bedout Island	WA
Bernier And Dorre Islands	WA
Bessieres Island	WA
Boodie, Double Middle Islands	WA
Broome Bird Observatory	WA
Broome Wildlife Centre	WA
Browse Island	WA
Bundegi Coastal Park	WA
Cane River (Mount Minnie and Nanutarra)	WA
Cape Range	WA
Coulomb Point	WA
Dambimangari	WA
Dambimangari	WA
Dirk Hartog Island	WA
Gnandaroo Island	WA
Jarrkunpungu	WA
Jinmarnkur	WA
Jinmarnkur Kulja	WA
Jurabi Coastal Park	WA
Kalbarri	WA
Karajarri	WA
Kujungurru Warrarn	WA

Name	State
Kujungurru Warrarn	WA
Lacepede Islands	WA
Little Rocky Island	WA
Locker Island	WA
Lowendal Islands	WA
Montebello Islands	WA
Muiron Islands	WA
Murujuga	WA
North Sandy Island	WA
North Turtle Island	WA
Nyangumarta Warrarn	WA
Part Murchison house	WA
Round Island	WA
Serrurier Island	WA
Swan Island	WA
Tamala Pastoral Lease (Part)	WA
Tanner Island	WA
Tent Island	WA
Unnamed WA26400	WA
Unnamed WA28968	WA
Unnamed WA36907	WA
Unnamed WA36909	WA
Unnamed WA36910	WA
Unnamed WA36913	WA
Unnamed WA36915	WA
Unnamed WA37168	WA
Unnamed WA37500	WA
Unnamed WA38287	WA
Unnamed WA40322	WA
Unnamed WA40828	WA
Unnamed WA40877	WA
Unnamed WA41080	WA
Unnamed WA41775	WA
Unnamed WA44665	WA
Unnamed WA44667	WA
Unnamed WA44669	WA
Unnamed WA44672	WA
Unnamed WA44673	WA
Unnamed WA48858	WA
Unnamed WA51105	WA
Unnamed WA51162	WA
Unnamed WA51497	WA
Unnamed WA51583	WA
Unnamed WA51617	WA
Unnamed WA51932	WA
Unnamed WA52354	WA
Unnamed WA52366	WA
Unnamed WA53015	WA
Unguu	WA
Victor Island	WA
Wanagarren	WA
Wedge Island	WA
Weld Island	WA
Whitmore,Roberts,Doole Islands And Sandalwood Landing	WA
Y Island	WA
Yampi	WA
Yawuru	WA
Zuytdorp	WA

Invasive Species

[[Resource Information](#)]

Weeds reported here are the 20 species of national significance (WoNS), along with other introduced plants that are considered by the States and Territories to pose a particularly significant threat to biodiversity. The following feral animals are reported: Goat, Red Fox, Cat, Rabbit, Pig, Water Buffalo and Cane Toad. Maps from Landscape Health Project, National Land and Water Resources Audit, 2001.

Name	Status	Type of Presence
Birds		
Anas platyrhynchos Mallard [974]		Species or species habitat likely to occur within area
Columba livia Rock Pigeon, Rock Dove, Domestic Pigeon [803]		Species or species habitat likely to occur within area
Gallus gallus Red Junglefowl, Feral Chicken, Domestic Fowl [917]		Species or species habitat likely to occur within area
Gallus varius Green Junglefowl [81207]		Species or species habitat likely to occur within area
Lonchura oryzivora Java Sparrow [59586]		Species or species habitat likely to occur within area
Meleagris gallopavo Wild Turkey [64380]		Species or species habitat likely to occur within area
Passer domesticus House Sparrow [405]		Species or species habitat likely to occur within area
Passer montanus Eurasian Tree Sparrow [406]		Species or species habitat likely to occur within area
Streptopelia senegalensis Laughing Turtle-dove, Laughing Dove [781]		Species or species habitat likely to occur within area
Sturnus vulgaris Common Starling [389]		Species or species habitat likely to occur within area
Frogs		
Rhinella marina Cane Toad [83218]		Species or species habitat likely to occur within area
Mammals		
Bos taurus Domestic Cattle [16]		Species or species habitat likely to occur within area
Camelus dromedarius Dromedary, Camel [7]		Species or species habitat likely to occur within area
Canis lupus familiaris Domestic Dog [82654]		Species or species habitat likely to occur within area
Capra hircus Goat [2]		Species or species habitat likely to occur within area
Equus asinus Donkey, Ass [4]		Species or species habitat likely to occur within area
Equus caballus Horse [5]		Species or species habitat likely to occur within area
Felis catus Cat, House Cat, Domestic Cat [19]		Species or species

Name	Status	Type of Presence
Feral deer		habitat likely to occur within area
Feral deer species in Australia [85733]		Species or species habitat likely to occur within area
Mus musculus		
House Mouse [120]		Species or species habitat likely to occur within area
Oryctolagus cuniculus		
Rabbit, European Rabbit [128]		Species or species habitat likely to occur within area
Rattus exulans		
Pacific Rat, Polynesian Rat [79]		Species or species habitat likely to occur within area
Rattus rattus		
Black Rat, Ship Rat [84]		Species or species habitat likely to occur within area
Sus scrofa		
Pig [6]		Species or species habitat likely to occur within area
Vulpes vulpes		
Red Fox, Fox [18]		Species or species habitat likely to occur within area
Plants		
Andropogon gayanus		
Gamba Grass [66895]		Species or species habitat likely to occur within area
Asparagus asparagoides		
Bridal Creeper, Bridal Veil Creeper, Smilax, Florist's Smilax, Smilax Asparagus [22473]		Species or species habitat likely to occur within area
Brachiaria mutica		
Para Grass [5879]		Species or species habitat may occur within area
Cenchrus ciliaris		
Buffel-grass, Black Buffel-grass [20213]		Species or species habitat likely to occur within area
Chrysanthemoides monilifera		
Bitou Bush, Boneseed [18983]		Species or species habitat may occur within area
Chrysanthemoides monilifera subsp. monilifera		
Boneseed [16905]		Species or species habitat likely to occur within area
Dolichandra unguis-cati		
Cat's Claw Vine, Yellow Trumpet Vine, Cat's Claw Creeper, Funnel Creeper [85119]		Species or species habitat likely to occur within area
Genista sp. X Genista monspessulana		
Broom [67538]		Species or species habitat may occur within area
Jatropha gossypifolia		
Cotton-leaved Physic-Nut, Bellyache Bush, Cotton-leaf Physic Nut, Cotton-leaf Jatropha, Black Physic Nut [7507]		Species or species habitat likely to occur within area
Lantana camara		
Lantana, Common Lantana, Kamara Lantana, Large-leaf Lantana, Pink Flowered Lantana, Red Flowered Lantana, Red-Flowered Sage, White Sage, Wild Sage [10892]		Species or species habitat likely to occur within area

Name	Status	Type of Presence
Lycium ferocissimum African Boxthorn, Boxthorn [19235]		Species or species habitat likely to occur within area
Olea europaea Olive, Common Olive [9160]		Species or species habitat may occur within area
Opuntia spp. Prickly Pears [82753]		Species or species habitat likely to occur within area
Parkinsonia aculeata Parkinsonia, Jerusalem Thorn, Jelly Bean Tree, Horse Bean [12301]		Species or species habitat likely to occur within area
Pinus radiata Radiata Pine Monterey Pine, Insignis Pine, Wilding Pine [20780]		Species or species habitat may occur within area
Prosopis spp. Mesquite, Algaroba [68407]		Species or species habitat likely to occur within area
Tamarix aphylla Athel Pine, Athel Tree, Tamarisk, Athel Tamarisk, Athel Tamarix, Desert Tamarisk, Flowering Cypress, Salt Cedar [16018]		Species or species habitat likely to occur within area
Reptiles		
Hemidactylus frenatus Asian House Gecko [1708]		Species or species habitat likely to occur within area
Lepidodactylus lugubris Mourning Gecko [1712]		Species or species habitat likely to occur within area
Lycodon aulicus Wolf Snake, Common Wolf Snake, Asian Wolf Snake [83178]		Species or species habitat likely to occur within area
Lygosoma bowringii Christmas Island Grass-skink [1312]		Species or species habitat likely to occur within area
Ramphotyphlops braminus Flowerpot Blind Snake, Brahminy Blind Snake, Cacing Besi [1258]		Species or species habitat known to occur within area

Nationally Important Wetlands		[Resource Information]
Name		State
"The Dales", Christmas Island		EXT
Ashmore Reef		EXT
Bunda-Bunda Mound Springs		WA
Bundera Sinkhole		WA
Cape Range Subterranean Waterways		WA
De Grey River		WA
Eighty Mile Beach System		WA
Exmouth Gulf East		WA
Hosine's Spring, Christmas Island		EXT
Learmonth Air Weapons Range - Saline Coastal Flats		WA
Leslie (Port Hedland) Saltfields System		WA
Mermaid Reef		EXT
Murchison River (Lower Reaches)		WA
Pulu Keeling National Park		EXT
Roebuck Bay		WA
Shark Bay East		WA
Willie Creek Wetlands		WA
Yampi Sound Training Area		WA

Key Ecological Features are the parts of the marine ecosystem that are considered to be important for the biodiversity or ecosystem functioning and integrity of the Commonwealth Marine Area.

Name	Region
Ancient coastline at 125 m depth contour	North-west
Ashmore Reef and Cartier Island and surrounding	North-west
Canyons linking the Argo Abyssal Plain with the	North-west
Canyons linking the Cuvier Abyssal Plain and the	North-west
Commonwealth waters adjacent to Ningaloo Reef	North-west
Continental Slope Demersal Fish Communities	North-west
Exmouth Plateau	North-west
Glomar Shoals	North-west
Mermaid Reef and Commonwealth waters	North-west
Seringapatam Reef and Commonwealth waters in	North-west
Wallaby Saddle	North-west
Ancient coastline at 90-120m depth	South-west
Commonwealth marine environment surrounding	South-west
Commonwealth marine environment within and	South-west
Perth Canyon and adjacent shelf break, and other	South-west
Western demersal slope and associated fish	South-west
Western rock lobster	South-west

Caveat

The information presented in this report has been provided by a range of data sources as acknowledged at the end of the report.

This report is designed to assist in identifying the locations of places which may be relevant in determining obligations under the Environment Protection and Biodiversity Conservation Act 1999. It holds mapped locations of World and National Heritage properties, Wetlands of International and National Importance, Commonwealth and State/Territory reserves, listed threatened, migratory and marine species and listed threatened ecological communities. Mapping of Commonwealth land is not complete at this stage. Maps have been collated from a range of sources at various resolutions.

Not all species listed under the EPBC Act have been mapped (see below) and therefore a report is a general guide only. Where available data supports mapping, the type of presence that can be determined from the data is indicated in general terms. People using this information in making a referral may need to consider the qualifications below and may need to seek and consider other information sources.

For threatened ecological communities where the distribution is well known, maps are derived from recovery plans, State vegetation maps, remote sensing imagery and other sources. Where threatened ecological community distributions are less well known, existing vegetation maps and point location data are used to produce indicative distribution maps.

Threatened, migratory and marine species distributions have been derived through a variety of methods. Where distributions are well known and if time permits, maps are derived using either thematic spatial data (i.e. vegetation, soils, geology, elevation, aspect, terrain, etc) together with point locations and described habitat; or environmental modelling (MAXENT or BIOCLIM habitat modelling) using point locations and environmental data layers.

Where very little information is available for species or large number of maps are required in a short time-frame, maps are derived either from 0.04 or 0.02 decimal degree cells; by an automated process using polygon capture techniques (static two kilometre grid cells, alpha-hull and convex hull); or captured manually or by using topographic features (national park boundaries, islands, etc). In the early stages of the distribution mapping process (1999-early 2000s) distributions were defined by degree blocks, 100K or 250K map sheets to rapidly create distribution maps. More reliable distribution mapping methods are used to update these distributions as time permits.

Only selected species covered by the following provisions of the EPBC Act have been mapped:

- migratory and
- marine

The following species and ecological communities have not been mapped and do not appear in reports produced from this database:

- threatened species listed as extinct or considered as vagrants
- some species and ecological communities that have only recently been listed
- some terrestrial species that overfly the Commonwealth marine area
- migratory species that are very widespread, vagrant, or only occur in small numbers

The following groups have been mapped, but may not cover the complete distribution of the species:

- non-threatened seabirds which have only been mapped for recorded breeding sites
- seals which have only been mapped for breeding sites near the Australian continent

Such breeding sites may be important for the protection of the Commonwealth Marine environment.

Coordinates

-8.046 94.681,-7.967 101.047,-7.981 104.981,-6.805 104.579,-6.805 105.013,-7.43 106.613,-7.794 108.485,-7.811 109.734,-8.297 111.467,-8.279 111.849,-8.609 114.068,-8.366 114.71,-8.054 116.131,-8.106 117.345,-8.401 119.374,-8.47 122.998,-8.245 123.847,-9.756 123.671,-10.19 123.505,-10.979 122.921,-11.294 123.371,-12.32 123.742,-12.99 124.736,-13.803 124.349,-14.955 124.818,-15.475 124.662,-16.168 124.662,-16.411 124.437,-16.775 123.327,-16.793 122.772,-17.434 122.217,-18.058 122.391,-19.467 121.324,-19.805 120.878,-20.005 120.375,-20.174 119.682,-20.169 119.222,-20.395 118.806,-20.503 118.208,-20.703 117.857,-20.854 117.363,-20.768 117.046,-20.802 116.647,-21.119 116.188,-21.379 115.984,-21.765 115.395,-22.012 114.575,-22.044 114.478,-22.145 114.335,-22.166 114.316,-22.331 114.259,-22.363 114.203,-22.374 114.155,-22.343 114.179,-22.304 114.173,-22.305 114.146,-22.323 114.124,-22.291 114.124,-22.264 114.132,-22.198 114.085,-22.162 114.082,-22.101 114.096,-22.038 114.119,-21.937 114.137,-21.865 114.149,-21.815 114.19,-21.786 114.165,-21.807 114.127,-21.799 114.107,-21.876 113.995,-22.006 113.924,-22.233 113.84,-22.303 113.822,-22.361 113.786,-22.382 113.764,-22.495 113.724,-22.498 113.71,-22.514 113.714,-22.544 113.683,-22.551 113.662,-22.582 113.656,-22.596 113.673,-22.614 113.673,-22.628 113.667,-22.665 113.685,-22.695 113.671,-22.721 113.674,-22.714 113.709,-22.751 113.75,-22.784 113.769,-22.812 113.773,-22.834 113.791,-22.886 113.799,-22.904 113.815,-23.136 113.777,-23.482 113.701,-23.694 113.555,-23.959 113.479,-24.108 113.384,-24.206 113.192,-24.508 113.125,-25.033 113.02,-25.156 113.106,-25.246 112.945,-25.567 112.882,-25.785 112.967,-25.855 113.021,-26.364 113.223,-27.079 113.211,-27.18 113.947,-27.426 114.074,-27.752 114.14,-28.571 113.415,-28.856 113.885,-29.171 114.212,-29.045 114.823,-29.339 114.422,-29.89 114.763,-30.475 114.646,-30.843 114.858,-30.788 115.191,-30.799 115.191,-30.895 115.076,-31.312 115.395,-31.751 115.024,-32.271 114.953,-33.329 114.618,-33.597 114.173,-32.556 113.883,-31.798 113.336,-31.482 111.719,-30.091 108.52,-27.958 105.412,-25.719 104.165,-23.656 102.52,-23.622 100.09,-20.911 98.638,-20.655 97.43,-19.632 95.895,-17.995 95.179,-15.779 93.065,-14.79 92.485,-13.211 94.631,-10.844 94.725,-9.879 91.854,-8.046 94.681

Acknowledgements

This database has been compiled from a range of data sources. The department acknowledges the following custodians who have contributed valuable data and advice:

- [-Office of Environment and Heritage, New South Wales](#)
- [-Department of Environment and Primary Industries, Victoria](#)
- [-Department of Primary Industries, Parks, Water and Environment, Tasmania](#)
- [-Department of Environment, Water and Natural Resources, South Australia](#)
- [-Department of Land and Resource Management, Northern Territory](#)
- [-Department of Environmental and Heritage Protection, Queensland](#)
- [-Department of Parks and Wildlife, Western Australia](#)
- [-Environment and Planning Directorate, ACT](#)
- [-Birdlife Australia](#)
- [-Australian Bird and Bat Banding Scheme](#)
- [-Australian National Wildlife Collection](#)
- [-Natural history museums of Australia](#)
- [-Museum Victoria](#)
- [-Australian Museum](#)
- [-South Australian Museum](#)
- [-Queensland Museum](#)
- [-Online Zoological Collections of Australian Museums](#)
- [-Queensland Herbarium](#)
- [-National Herbarium of NSW](#)
- [-Royal Botanic Gardens and National Herbarium of Victoria](#)
- [-Tasmanian Herbarium](#)
- [-State Herbarium of South Australia](#)
- [-Northern Territory Herbarium](#)
- [-Western Australian Herbarium](#)
- [-Australian National Herbarium, Canberra](#)
- [-University of New England](#)
- [-Ocean Biogeographic Information System](#)
- [-Australian Government, Department of Defence Forestry Corporation, NSW](#)
- [-Geoscience Australia](#)
- [-CSIRO](#)
- [-Australian Tropical Herbarium, Cairns](#)
- [-eBird Australia](#)
- [-Australian Government – Australian Antarctic Data Centre](#)
- [-Museum and Art Gallery of the Northern Territory](#)
- [-Australian Government National Environmental Science Program](#)
- [-Australian Institute of Marine Science](#)
- [-Reef Life Survey Australia](#)
- [-American Museum of Natural History](#)
- [-Queen Victoria Museum and Art Gallery, Inveresk, Tasmania](#)
- [-Tasmanian Museum and Art Gallery, Hobart, Tasmania](#)
- [-Other groups and individuals](#)

The Department is extremely grateful to the many organisations and individuals who provided expert advice and information on numerous draft distributions.

Please feel free to provide feedback via the [Contact Us](#) page.

© Commonwealth of Australia

Department of Agriculture Water and the Environment

GPO Box 858

Canberra City ACT 2601 Australia

+61 2 6274 1111